

2000HP Multi-turn Direct Gas Pipeline Pneumatic Actuators

High Pressure Gas Power For Rapid Response For Gate And Large
Bore Quarter-Turn Valves



Designed To Handle Every High Pressure Valve Control Need On Your Pipeline

The EIM 2000HP pneumatic actuator from Emerson is a multi turn gas driven actuator that is perfect for applications using linear, rising stem or rotating stem valves. Developed for operation in the natural gas industry, the 2000HP actuates pipeline valves using the pipeline's own gas pressure as its power source.

The robust actuator is based on the proven EIM Series 2000 platform, with more than a half-century of outstanding field performance around the globe. It has the most durable internal components in the industry, assuring long-term reliability.

Widely used throughout all industries since the 1970s, the 2000HP is well suited for any industrial or pipeline application where compact design, simple manual override, travel limits, and torque protection are desired. It is ideal for situations such as compressor stations where electric motors would disrupt cathodic protection systems.

The 2000HP can handle virtually any local or remote control system requirement. A variety of standard single or double acting pneumatic and electric remote control configurations are available with optional electric limit switches.

The actuator, as an independent unit, is capable of producing 1,200 ft/lb (1,626 Nm) and 45,000 lb (200.18 kN) of thrust. Torque outputs up to 135,000 lb/ft (183,036 Nm) and thrust outputs up to 900,000 lbs (4,003.6 kN) can be attained through the addition of bevel or worm gearboxes.

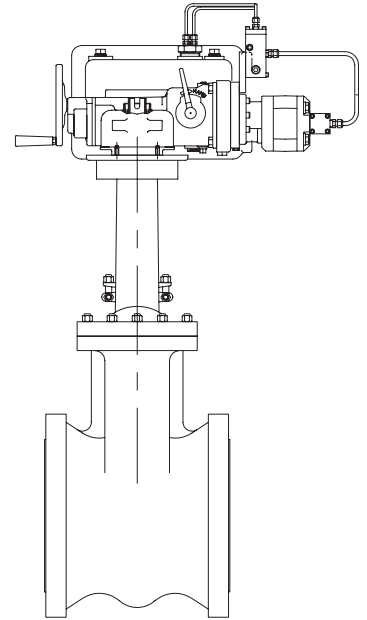

2000HP Is Distinctive

- Adaptable to quarter-turn or multi-turn applications
- Directly mountable on rising stem valves
- Manual override, travel limits and torque protection are standard
- Highly visible position indication dial available when using electric control pack
- Usable with bevel or worm gears
- Local/remote controls
- Padlockable clutch handle in either hand or motor position
- Handwheel operation in power loss or emergency operation
- Corrosion resistant valving
- MSS or ISO mounting flanges

2000HP Offers Numerous Benefits

- More economical than linear piston actuators
- Provides reliable emergency shutdown service
- Can be equipped for operation with nitrogen or natural gas
- Hundreds of torque/thrust/speed combinations available
- Compact design for space saving installations
- Mechanically locks valve in place when idle
- Eliminates hydraulic manual override

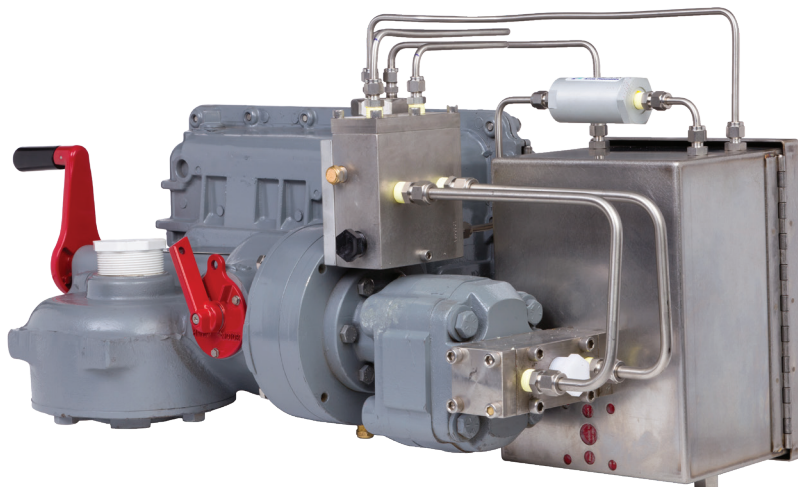

2000HP Features

- Built using the same rugged design of the EIM Series 2000 electric actuator

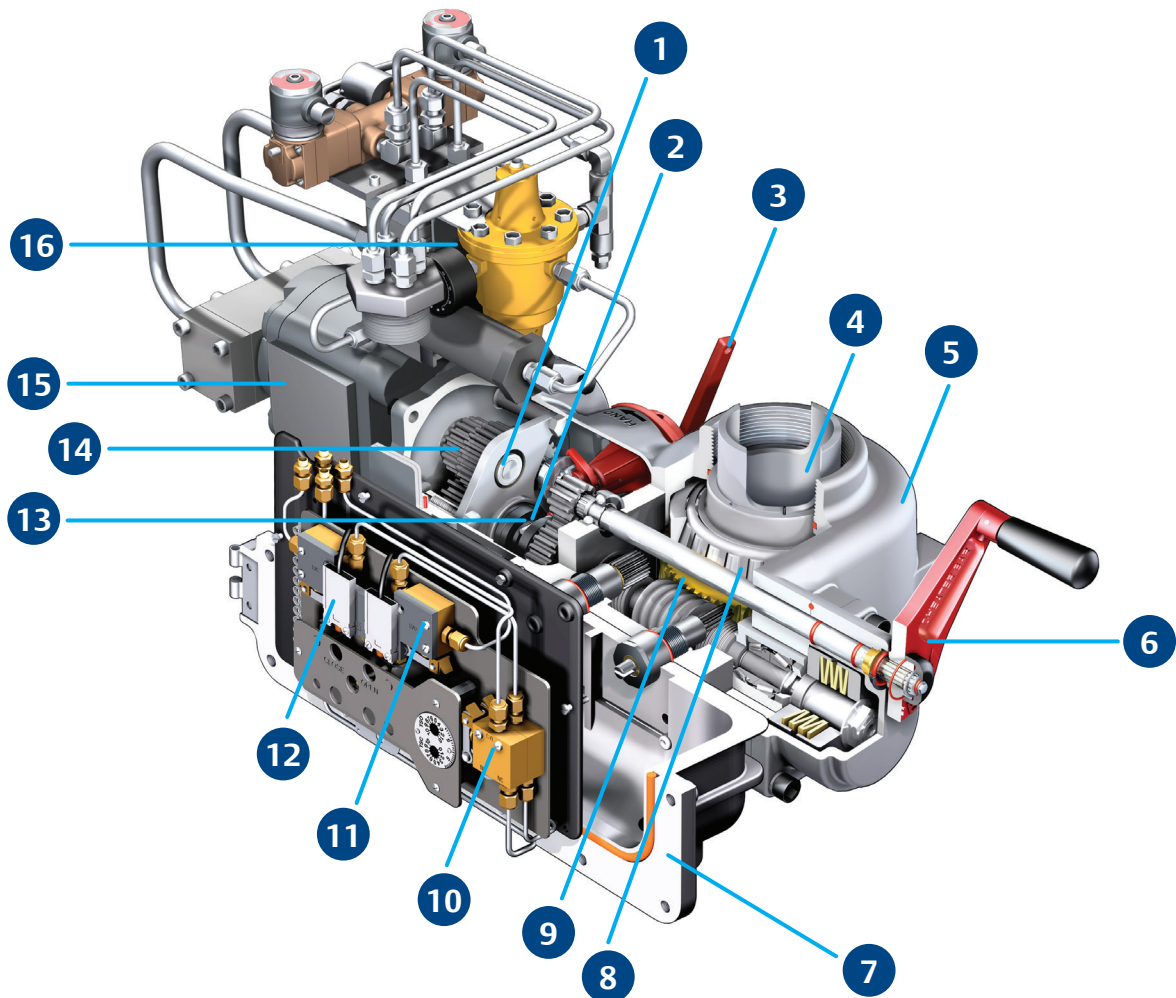

Rugged Features Are Integral To The 2000HP Design

- | | | | |
|---|---|----|---|
| 1 | Bearing supported shafts (no bushings) | 9 | Permanently self-locking worm and wheel |
| 2 | Automatic motor priority | 10 | Torque protection (internal and standard) |
| 3 | Low declutch force | 11 | Travel limits (internal and standard) |
| 4 | Valve stem never disengages from the drive sleeve | 12 | Position indication (optional) |
| 5 | Ductile iron housing | 13 | Low torque side declutching |
| 6 | Low rim-pull (80 lbs/350N maximum) | 14 | Alloy steel motor gear selections allow numerous speed and torque output combinations |
| 7 | Hinged cover, O-ring sealed controls enclosure | 15 | High pressure gear motor |
| 8 | Tapered top and bottom roller bearings | 16 | Pressure regulator and manually-operated selector valve are protected in a stainless steel padlockable control box-standard (not shown) |

2000HP Control Details

- Control power supply regulated to 100 psi (6.9 Bar)
- Motor and pilot block supply pressure 1,480 psi (102 Bar) maximum
- Local control function utilizing manually-operated selector valve
- Meets ingress protection classification IP66

Control Options

- Optional electrical position indication switches available. Switch certification rating: II 2g Ex d IIc T6; IID Ex tD A21 IP66 T80C
- Optional electric remote operation available. Solenoid certification rating: Class I, Div I, Grp C&D; Class II, Div I Grp E, F, G. ATEX certified solenoids available on request
- Custom control schemes available

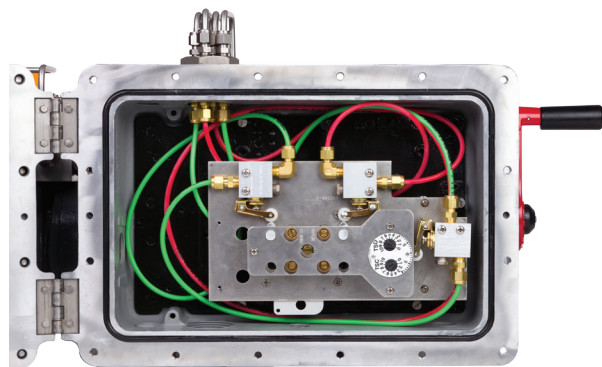

This product is only intended for use in large-scale fixed installations excluded from the scope of Directive 2011/65/EU on the restriction of the use of certain hazardous substances in electrical and electronic equipment (RoHS 2).

World Area Configuration Centers (WACC) offer sales support, service, inventory and commissioning to our global customers. Choose the WACC or sales office nearest you:

NORTH & SOUTH AMERICA

19200 Northwest Freeway
Houston TX 77065
USA
T +1 281 477 4100

Av. Hollingsworth
325 Iporanga Sorocaba
SP 18087-105
Brazil
T +55 15 3413 8888

ASIA PACIFIC

No. 9 Gul Road
#01-02 Singapore 629361
T +65 6777 8211

No. 1 Lai Yuan Road
Wuqing Development Area
Tianjin 301700
P. R. China
T +86 22 8212 3300

MIDDLE EAST & AFRICA

P. O. Box 17033
Jebel Ali Free Zone
Dubai
T +971 4 811 8100

P. O. Box 10305
Jubail 31961
Saudi Arabia
T +966 3 340 8650

24 Angus Crescent
Longmeadow Business Estate East
P.O. Box 6908 Greenstone
1616 Modderfontein Extension 5
South Africa
T +27 11 451 3700

EUROPE

Holland Fazor 6
Székesfehérvár 8000
Hungary
T +36 22 53 09 50

Strada Biffi 165
29017 Fiorenzuola d'Arda (PC)
Italy
T +39 0523 944 411

For complete list of sales and manufacturing sites, please visit www.emerson.com/actuationtechnologieslocations or contact us at info.actuationtechnologies@emerson.com

©2018 Emerson. All rights reserved.

The Emerson logo is a trademark and service mark of Emerson Electric Co. EIM™ is a mark of the Emerson family of companies. All other marks are property of their respective owners.