

## Series MS01

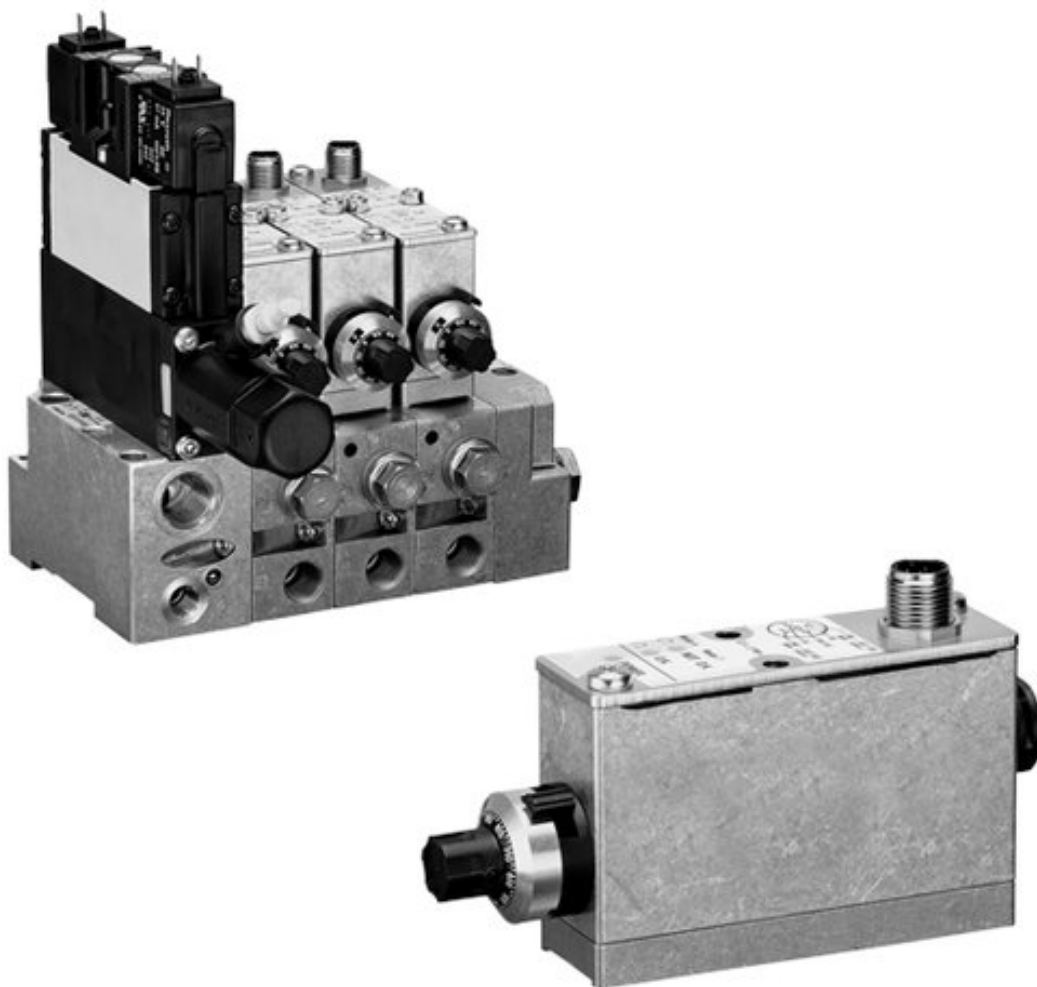

AVENTICS™ Series MS01



## Series MS01

- MS01-PA test block, variant I, with 2 x 3/2-directional valve
- subbase made of Polyamide fiber-glass reinforced
- cleaning pressure can be connected



Grid dimension	27 mm
Standards	ISO 15407-1 26 mm
Working pressure min./max.	4 ... 10 bar
Ambient temperature min./max.	0 ... 50 °C
Medium temperature min./max.	0 ... 50 °C
Medium	Compressed air
Max. particle size	5 µm
Oil content of compressed air	0 ... 0.1 mg/m <sup>3</sup>
DC operating voltage	24 V
Voltage tolerance DC	-10% / +10%
Protection class With valve plug connector	IP65
Duty cycle	100 %
Electrical connection for valve	Plug, form C
Electr. connection	Plug, M12, 5-pin
Valve voltage tolerance	-10% / +10%
Weight	See table below

### Technical data

Part No.	Version	port pneumatic	input 1	Exhaust R1	Output 4	pilot control R2 exhaust
3354418750	1x	according to ISO 228-1	G 1/4	G 1/8	Ø 6x1	G 1/8
3354418740	2x	according to ISO 228-1	G 1/4	G 1/8	Ø 6x1	G 1/8
3354418730	3x	according to ISO 228-1	G 1/4	G 1/8	Ø 6x1	G 1/8
3354418720	4x	according to ISO 228-1	G 1/4	G 1/8	Ø 6x1	G 1/8
3354418710	5x	according to ISO 228-1	G 1/4	G 1/8	Ø 6x1	G 1/8
3354418700	6x	according to ISO 228-1	G 1/4	G 1/8	Ø 6x1	G 1/8
R412011208	7x	according to ISO 228-1	G 1/4	G 1/8	Ø 6x1	G 1/8
R412011209	8x	according to ISO 228-1	G 1/4	G 1/8	Ø 6x1	G 1/8

Part No.	Min./max. detection distance	Length	Weight
3354418750	0.01 ... 0.3 mm	88 mm	1.57 kg
3354418740	0.01 ... 0.3 mm	115 mm	1.98 kg
3354418730	0.01 ... 0.3 mm	142 mm	2.39 kg
3354418720	0.01 ... 0.3 mm	169 mm	2.81 kg
3354418710	0.01 ... 0.3 mm	196 mm	3.22 kg
3354418700	0.01 ... 0.3 mm	223 mm	3.63 kg
R412011208	0.01 ... 0.3 mm	250 mm	4.04 kg
R412011209	0.01 ... 0.3 mm	277 mm	4.45 kg

The detection distance is based on one measuring point per test module and depends on the operating conditions. For more information, see operating instructions.

## Technical information

The pressure dew point must be at least 15 °C under ambient and medium temperature and may not exceed 3 °C .

The oil content of compressed air must remain constant during the life cycle.

Use only the approved oils from AVENTICS. Further information can be found in the “Technical information” document (available in the MediaCentre).

The pressure regulator is preset at 3 bar .

Expansion options available for pilot valves.

## Technical information

Material	
End plates	Aluminum
Seal	Acrylonitrile butadiene rubber
Subbase	Polyamide fiber-glass reinforced

## Dimensions

### Dimensions

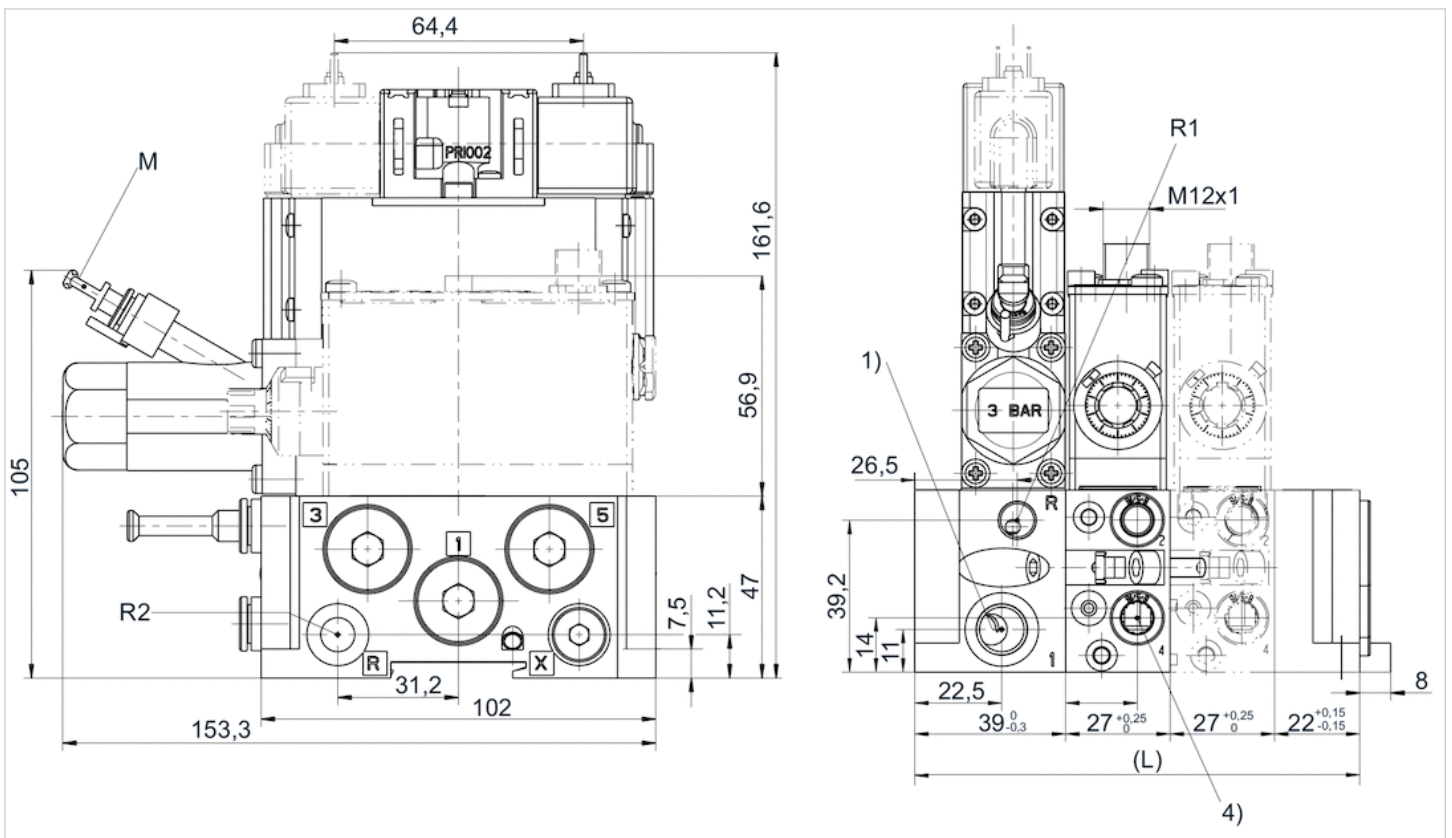

- 1) Operating pressure
- 4) Port 4 (to nozzle)
- R1) Test module exhaust/sealing air connection (max. 1 bar )
- R2) Pilot control exhaust
- M) Push-in fitting for plastic tubing Ø 6x1 of the pressure gauge
- L = length

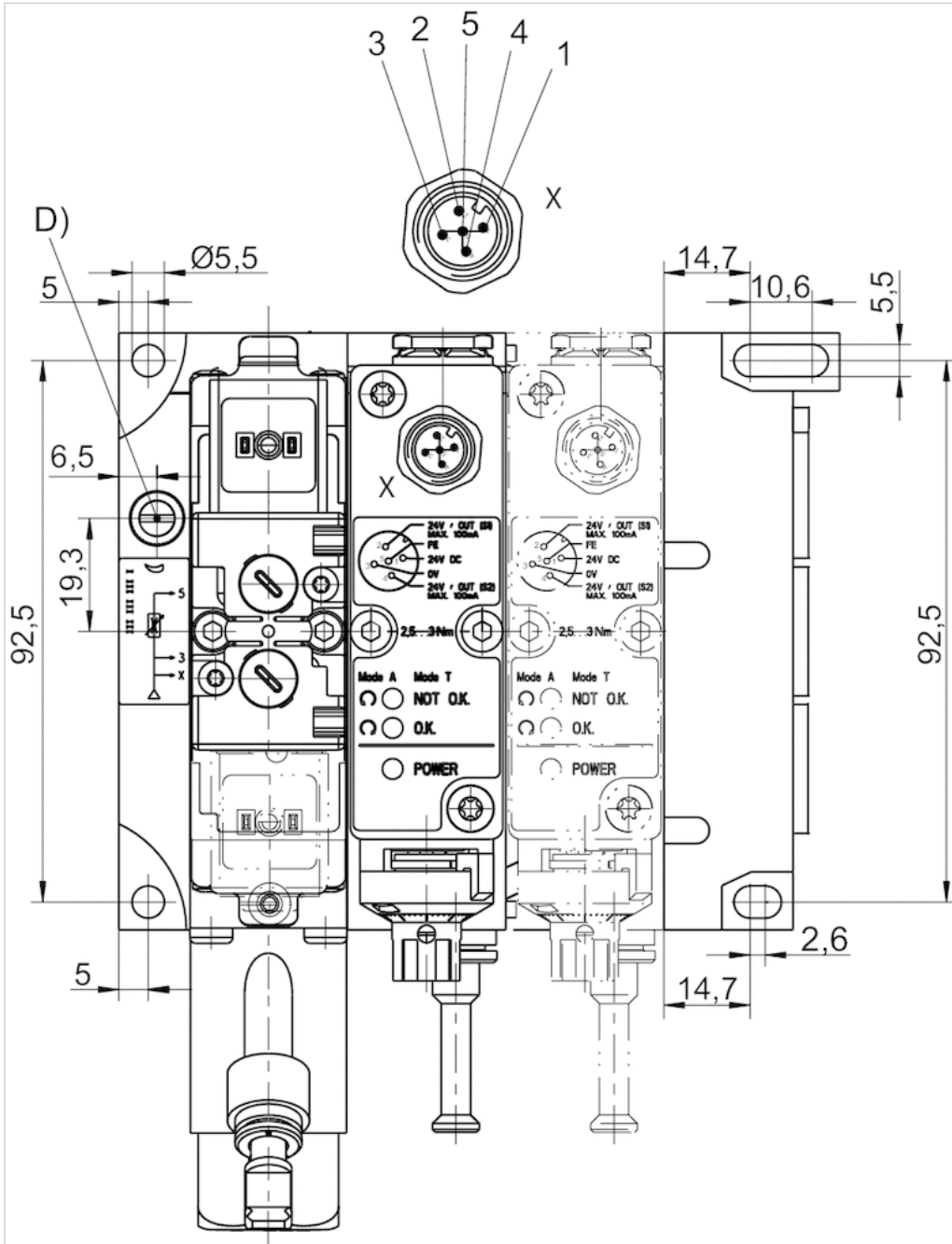

D = Throttle (cleaning pressure)

M12 contact assignment:

contact 1: 24 V DC

contact 2: output signal 24 V DC, S1 (working pressure), max. 100 mA

contact 3: 0 V

contact 4: output signal 24 V DC, S2 (testing), max. 100 mA

contact 5: FE

Circuit diagram

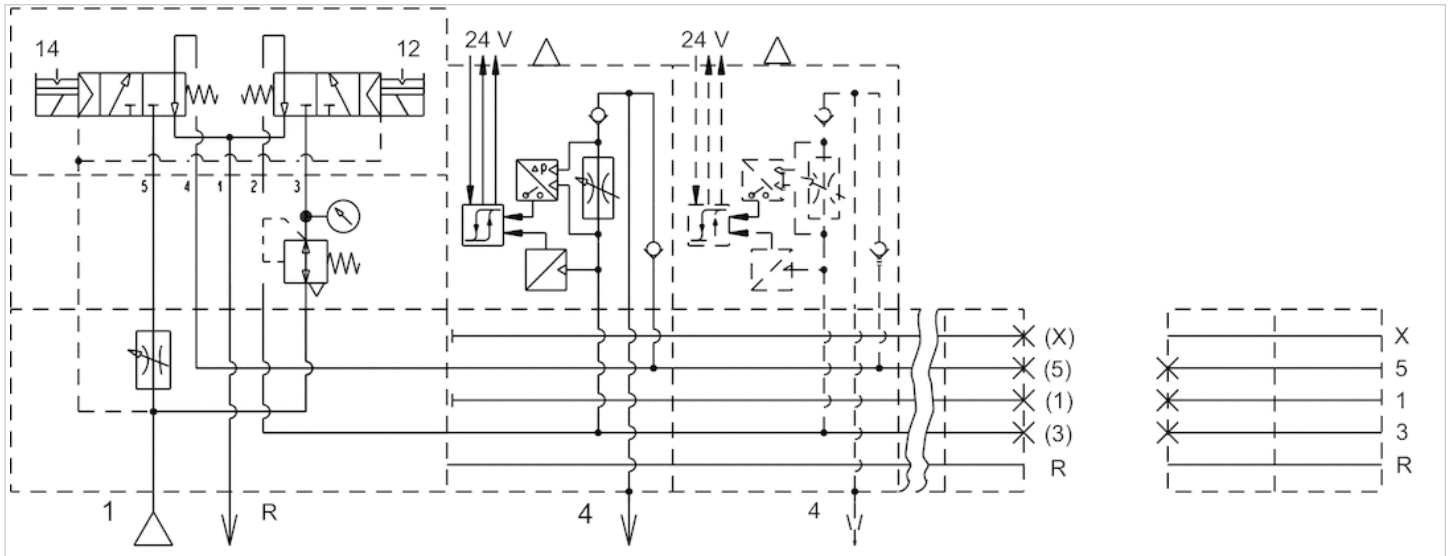

- Valve side 14: cleaning pressure
- Port 4: connection nozzle
- valve side 12: test pressure
- port R: exhaust (see dimensions for R1 and R2)

# Pneumatic position monitoring, Series MS01

- MS01 test module



Grid dimension	27 mm
Standards	ISO 15407-1 26 mm
Certificates	CE declaration of conformity
Compressed air connection	base plate DIN ISO 15407-1
Working pressure min./max.	2.7 ... 3.3 bar
Ambient temperature min./max.	0 ... 50 °C
Medium temperature min./max.	0 ... 50 °C
Medium	Compressed air
Max. particle size	5 µm
Oil content of compressed air	0 ... 0.1 mg/m <sup>3</sup>
cleaning pressure max.	10 bar
DC operating voltage	24 V
Voltage tolerance DC	-10% / +10%
Protection class	IP67
Duty cycle	100 %
Weight	0.282 kg

## Technical data

Part No.	Electrical connection	detection distance (nozzle Ø 1 mm/2 mm), min./max.
R412011545	Plug, M12, 5-pin	0.01, 0.3 mm

The detection distance is based on one measuring point per test module and depends on the operating conditions. For more information, see operating instructions.

## Technical information

The pressure dew point must be at least 15 °C under ambient and medium temperature and may not exceed 3 °C .

The oil content of compressed air must remain constant during the life cycle.

Use only the approved oils from AVENTICS. Further information can be found in the "Technical information" document (available in the MediaCentre).

## Technical information

Material	
Housing	Aluminum
Cap	Stainless steel

## Dimensions

## Circuit symbol

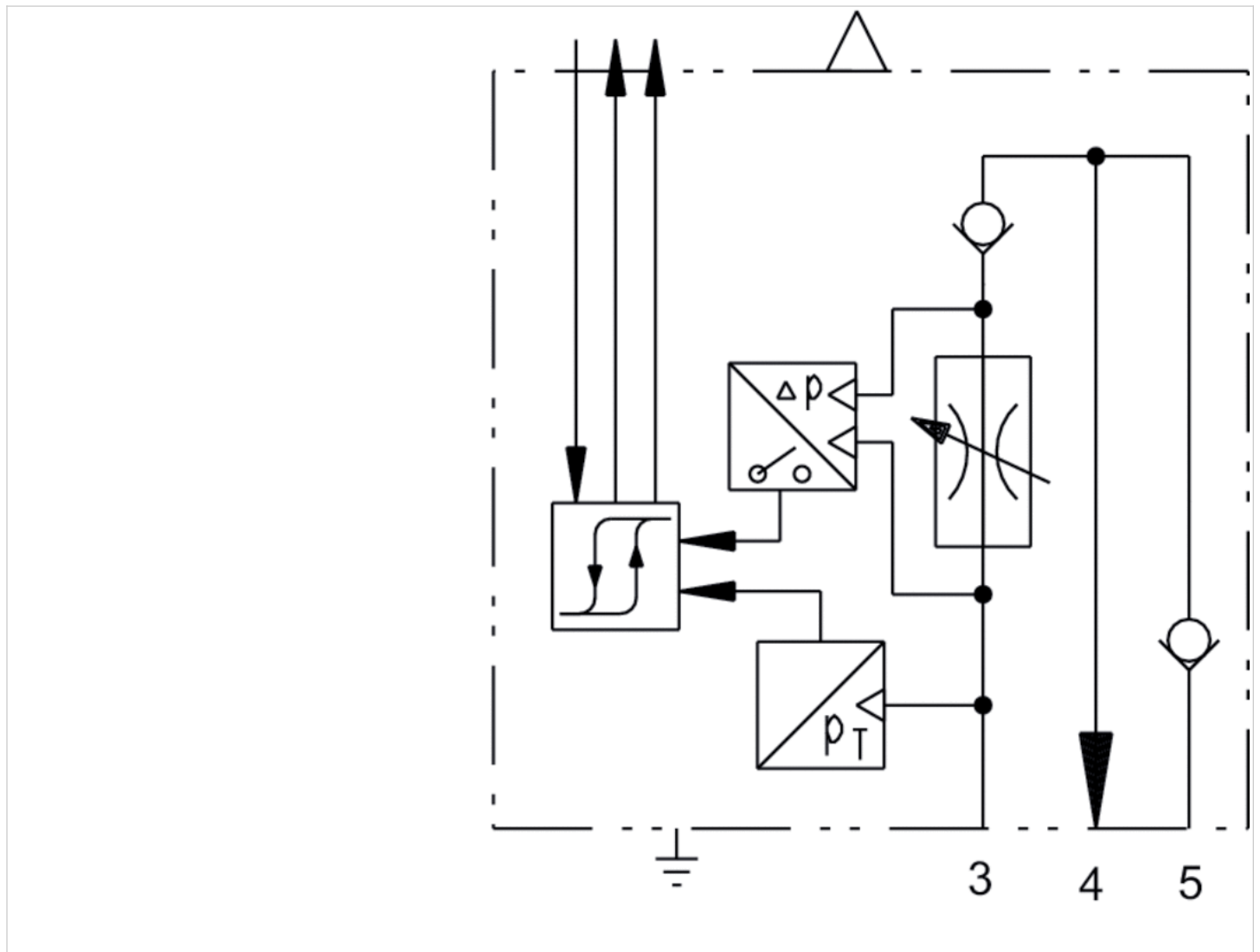

Dimensions

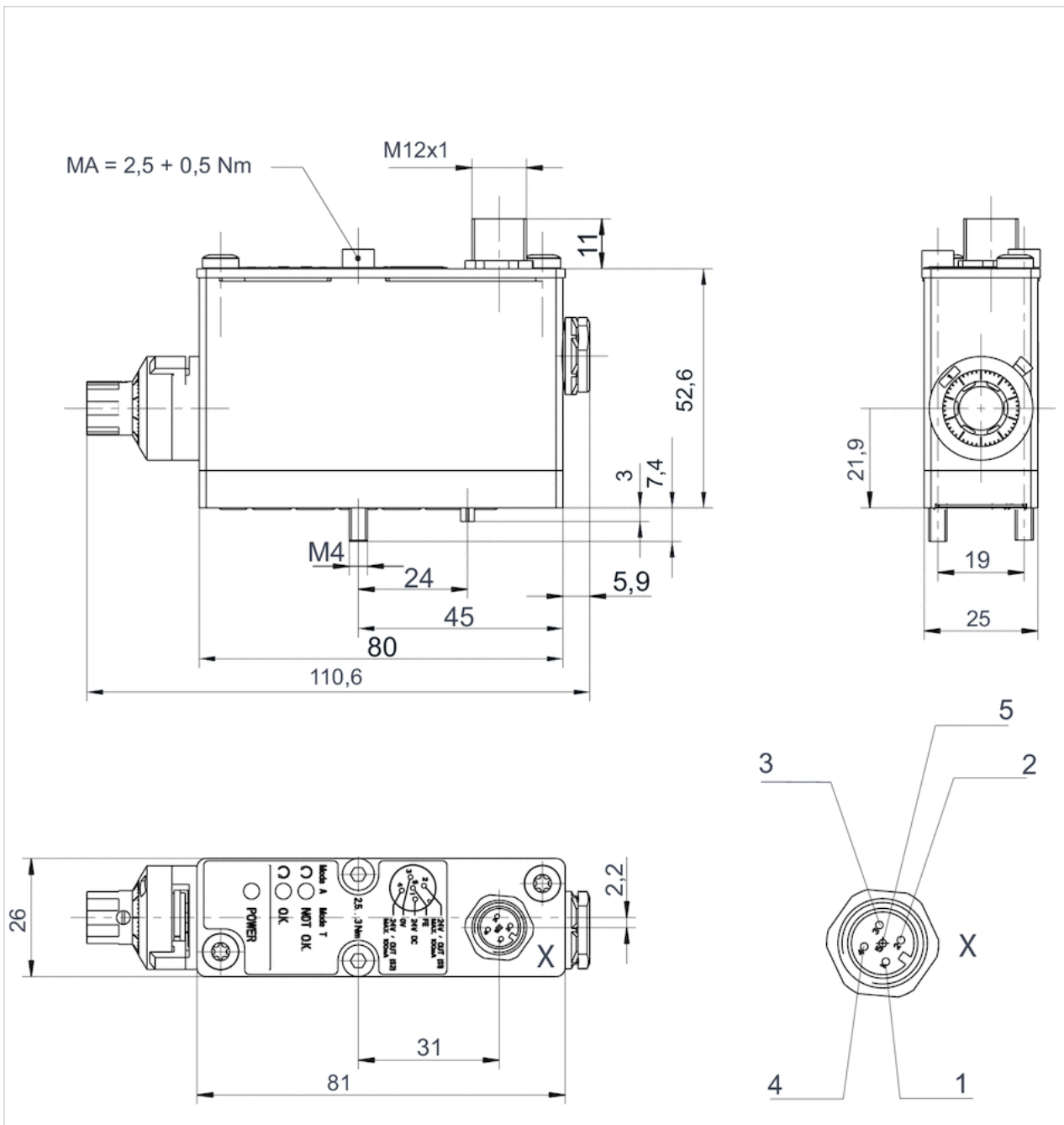

- M12 contact assignment:
- contact 1: 24 V DC
  - contact 2: output signal 24 V DC, S1 (working pressure), max. 100 mA
  - contact 3: 0 V
  - contact 4: output signal 24 V DC, S2 (testing), max. 100 mA
  - contact 5: FE



Pneumatic interface

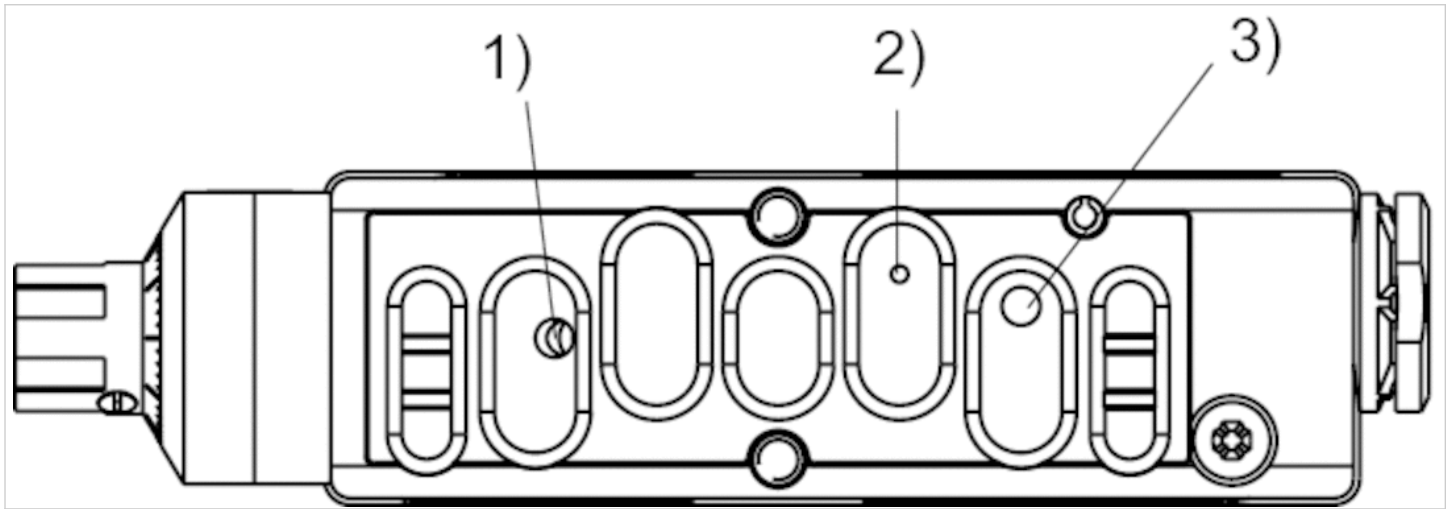

For use with a subbase with  
ISO 15407-1 hole pattern

- 1 = test pressure
- 2 = nozzle connection
- 3 = cleaning pressure

# Series MS01

- MS01-PA test block, variant II, with 5/2-directional valve
- subbase made of Polyamide fiber-glass reinforced
- permanent cleaning pressure



Grid dimension	27 mm
Standards	ISO 15407-1 26 mm
Working pressure min./max.	4 ... 10 bar
Ambient temperature min./max.	0 ... 50 °C
Medium temperature min./max.	0 ... 50 °C
Medium	Compressed air
Max. particle size	5 µm
Oil content of compressed air	0 ... 0.1 mg/m <sup>3</sup>
DC operating voltage	24 V
Voltage tolerance DC	-10% / +10%
Protection class With valve plug connector	IP65
Duty cycle	100 %
Electrical connection for valve	Plug, form C
Electr. connection	Plug, M12, 5-pin
Valve voltage tolerance	-10% / +10%
Weight	See table below

## Technical data

Part No.	Version	port pneumatic	input 1	Exhaust R1	Output 4	pilot control R2 exhaust
R412003461	1x	according to ISO 228-1	G 1/4	G 1/8	Ø 6x1	G 1/8
R412003462	2x	according to ISO 228-1	G 1/4	G 1/8	Ø 6x1	G 1/8
R412003463	3x	according to ISO 228-1	G 1/4	G 1/8	Ø 6x1	G 1/8
R412003464	4x	according to ISO 228-1	G 1/4	G 1/8	Ø 6x1	G 1/8
R412003465	5x	according to ISO 228-1	G 1/4	G 1/8	Ø 6x1	G 1/8
R412003466	6x	according to ISO 228-1	G 1/4	G 1/8	Ø 6x1	G 1/8
R412011212	7x	according to ISO 228-1	G 1/4	G 1/8	Ø 6x1	G 1/8
R412011213	8x	according to ISO 228-1	G 1/4	G 1/8	Ø 6x1	G 1/8

Part No.	Min./max. detection distance	Length	Weight
R412003461	0.01 ... 0.3 mm	88 mm	1.52 kg
R412003462	0.01 ... 0.3 mm	115 mm	1.93 kg
R412003463	0.01 ... 0.3 mm	142 mm	2.34 kg
R412003464	0.01 ... 0.3 mm	169 mm	2.76 kg
R412003465	0.01 ... 0.3 mm	196 mm	3.17 kg
R412003466	0.01 ... 0.3 mm	223 mm	3.58 kg
R412011212	0.01 ... 0.3 mm	250 mm	3.99 kg
R412011213	0.01 ... 0.3 mm	277 mm	4.4 kg

The detection distance is based on one measuring point per test module and depends on the operating conditions. For more information, see operating instructions.

## Technical information

The pressure dew point must be at least 15 °C under ambient and medium temperature and may not exceed 3 °C .

The oil content of compressed air must remain constant during the life cycle.

Use only the approved oils from AVENTICS. Further information can be found in the “Technical information” document (available in the MediaCentre).

The pressure regulator is preset at 3 bar .

Expansion options available for pilot valves.

## Technical information

Material	
End plates	Aluminum
Seal	Acrylonitrile butadiene rubber
Subbase	Polyamide fiber-glass reinforced

## Dimensions

### Dimensions

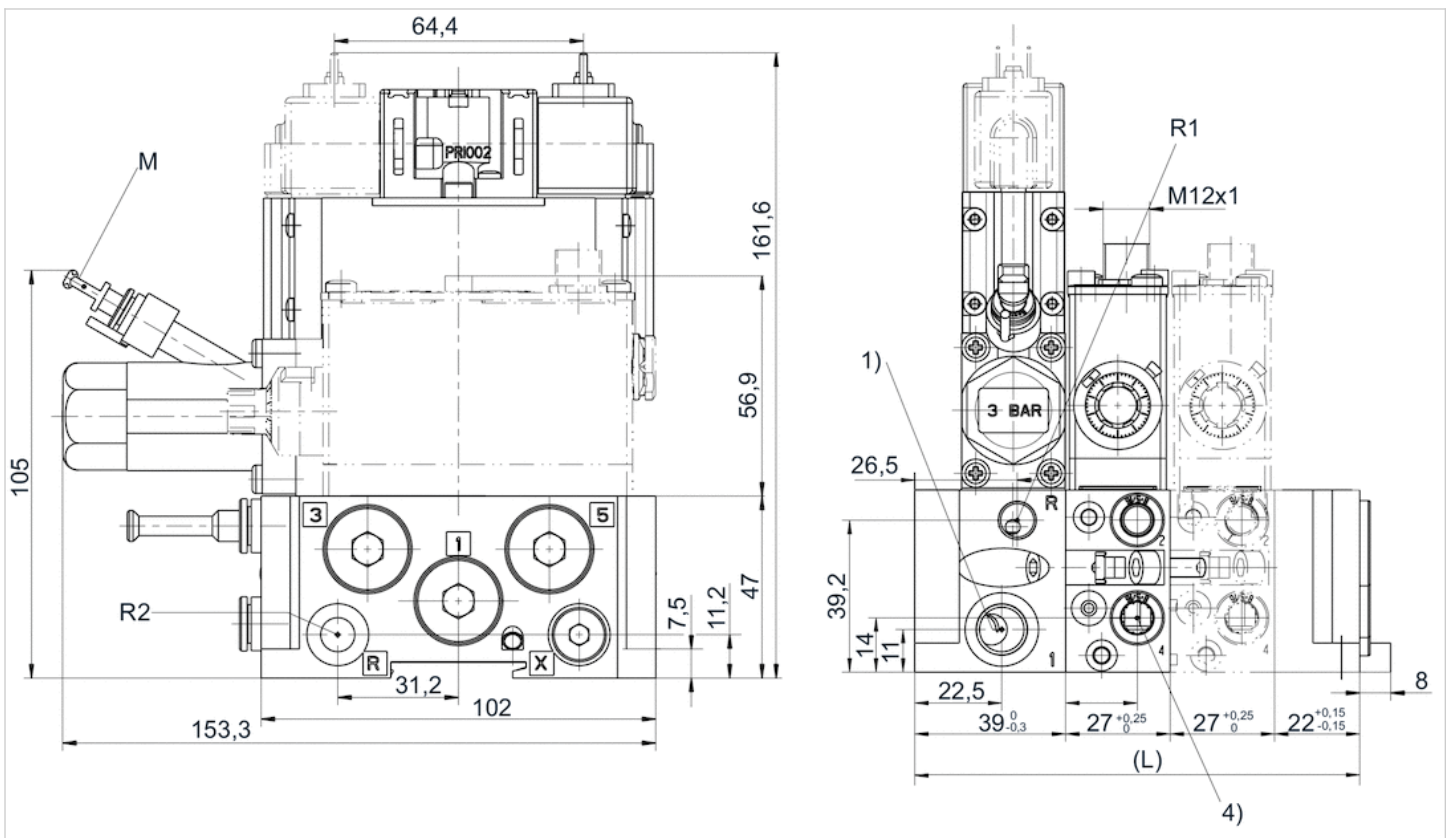

1) Operating pressure

4) Port 4 (to nozzle)

R1) Test module exhaust/sealing air connection (max. 1 bar )

R2) Pilot control exhaust

M) Push-in fitting for plastic tubing Ø 6x1 of the pressure gauge

L = length

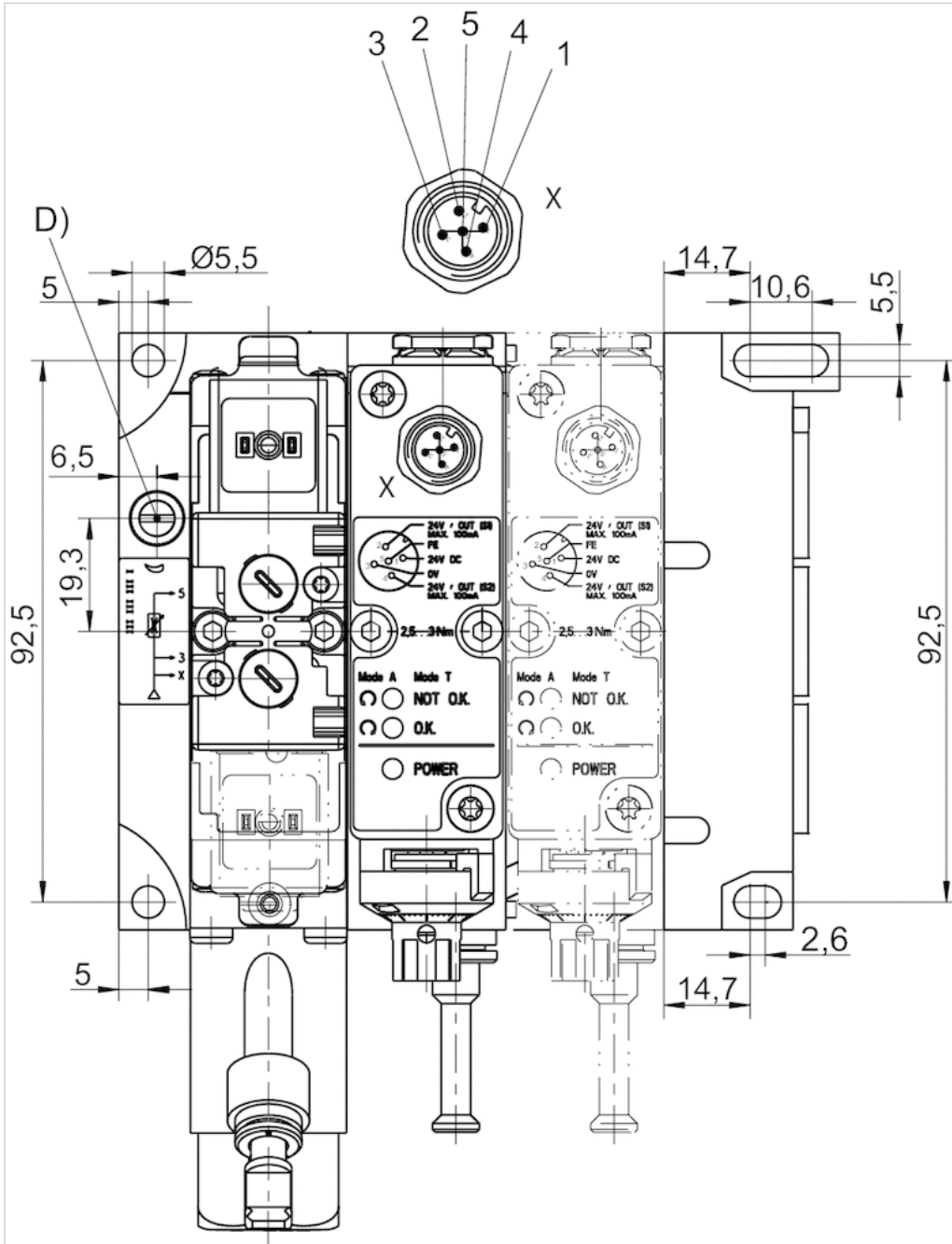

D = Throttle (cleaning pressure)

M12 contact assignment:

contact 1: 24 V DC

contact 2: output signal 24 V DC, S1 (working pressure), max. 100 mA

contact 3: 0 V

contact 4: output signal 24 V DC, S2 (testing), max. 100 mA

contact 5: FE

Circuit diagram

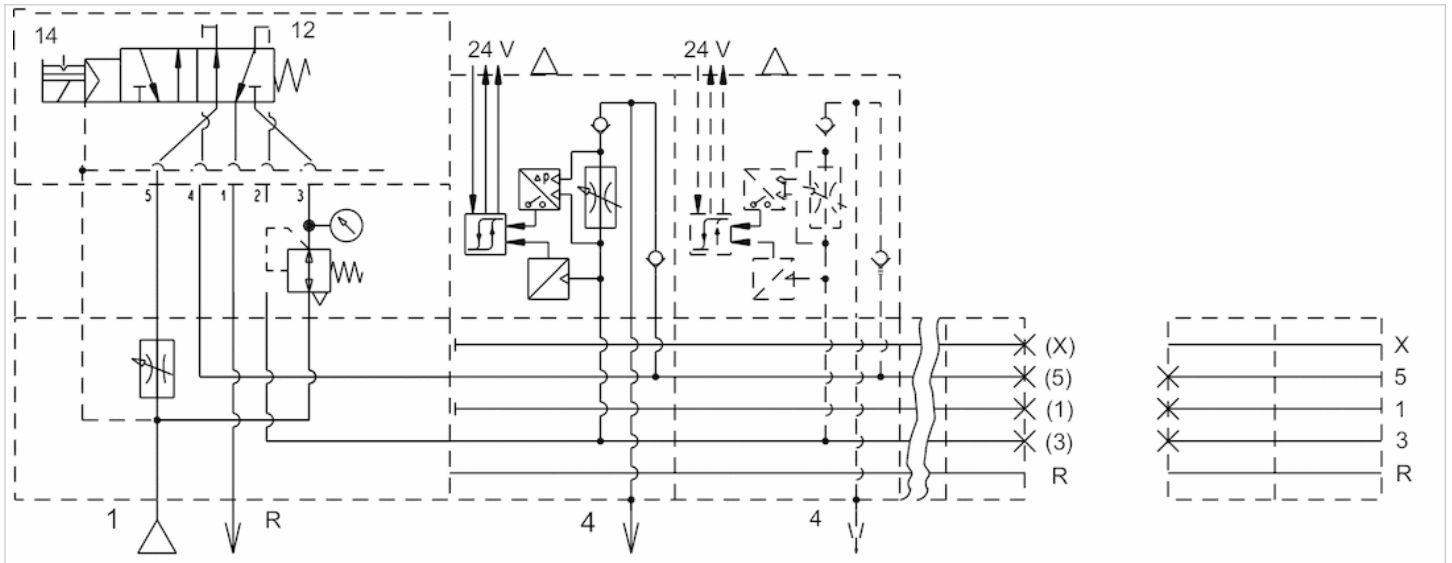

Valve side 14: test pressure  
 Port 4: connection nozzle  
 valve side 12: cleaning pressure  
 port R: exhaust (see dimensions for R1 and R2)

## Series MS01

- MS01-AL test block, variant I, with 2 x 3/2-directional valve
- subbase made of Die-cast aluminum
- cleaning pressure can be connected

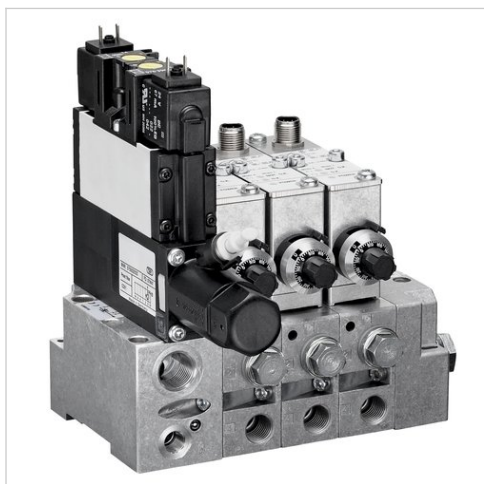

Grid dimension	27.1 mm
Standards	ISO 15407-1 26 mm
Working pressure min./max.	4 ... 10 bar
Ambient temperature min./max.	0 ... 50 °C
Medium temperature min./max.	0 ... 50 °C
Medium	Compressed air
Max. particle size	5 µm
Oil content of compressed air	0 ... 0.1 mg/m <sup>3</sup>
DC operating voltage	24 V
Voltage tolerance DC	-10% / +10%
Protection class With valve plug connector	IP65
Duty cycle	100 %
Electrical connection for valve	Plug, form C
Electr. connection	Plug, M12, 5-pin
Valve voltage tolerance	-10% / +10%
Weight	See table below

### Technical data

Part No.	Version	port pneumatic	input 1	Exhaust R1	Output 4	pilot control R2 exhaust
R412011175	1x	according to ISO 228-1	G 3/8	G 1/8	G 1/4	G 1/8
R412011176	2x	according to ISO 228-1	G 3/8	G 1/8	G 1/4	G 1/8
R412011177	3x	according to ISO 228-1	G 3/8	G 1/8	G 1/4	G 1/8
R412011178	4x	according to ISO 228-1	G 3/8	G 1/8	G 1/4	G 1/8
R412011179	5x	according to ISO 228-1	G 3/8	G 1/8	G 1/4	G 1/8
R412011180	6x	according to ISO 228-1	G 3/8	G 1/8	G 1/4	G 1/8
R412011181	7x	according to ISO 228-1	G 3/8	G 1/8	G 1/4	G 1/8
R412011182	8x	according to ISO 228-1	G 3/8	G 1/8	G 1/4	G 1/8
R412011183	1x	-	3/8 NPT	1/8 NPT	1/4 NPT	1/8 NPT
R412011184	2x	-	3/8 NPT	1/8 NPT	1/4 NPT	1/8 NPT
R412011185	3x	-	3/8 NPT	1/8 NPT	1/4 NPT	1/8 NPT
R412011186	4x	-	3/8 NPT	1/8 NPT	1/4 NPT	1/8 NPT
R412011187	5x	-	3/8 NPT	1/8 NPT	1/4 NPT	1/8 NPT
R412011188	6x	-	3/8 NPT	1/8 NPT	1/4 NPT	1/8 NPT
R412011189	7x	-	3/8 NPT	1/8 NPT	1/4 NPT	1/8 NPT
R412011190	8x	-	3/8 NPT	1/8 NPT	1/4 NPT	1/8 NPT

Part No.	Min./max. detection distance	Length	Weight
R412011175	0.01 ... 0.3 mm	93.1 mm	1.69 kg
R412011176	0.01 ... 0.3 mm	120.3 mm	2.17 kg
R412011177	0.01 ... 0.3 mm	147.4 mm	2.65 kg
R412011178	0.01 ... 0.3 mm	174.5 mm	3.12 kg
R412011179	0.01 ... 0.3 mm	201.6 mm	3.6 kg

Part No.	Min./max. detection distance	Length	Weight
R412011180	0.01 ... 0.3 mm	228.7 mm	4.08 kg
R412011181	0.01 ... 0.3 mm	255.8 mm	4.56 kg
R412011182	0.01 ... 0.3 mm	282.9 mm	5.03 kg
R412011183	0.01 ... 0.3 mm	93.1 mm	1.69 kg
R412011184	0.01 ... 0.3 mm	120.3 mm	2.17 kg
R412011185	0.01 ... 0.3 mm	147.4 mm	2.65 kg
R412011186	0.01 ... 0.3 mm	174.5 mm	3.12 kg
R412011187	0.01 ... 0.3 mm	201.6 mm	3.6 kg
R412011188	0.01 ... 0.3 mm	228.7 mm	4.08 kg
R412011189	0.01 ... 0.3 mm	255.8 mm	4.56 kg
R412011190	0.01 ... 0.3 mm	282.9 mm	5.03 kg

The detection distance is based on one measuring point per test module and depends on the operating conditions. For more information, see operating instructions.

## Technical information

The pressure dew point must be at least 15 °C under ambient and medium temperature and may not exceed 3 °C .

The oil content of compressed air must remain constant during the life cycle.

Use only the approved oils from AVENTICS. Further information can be found in the "Technical information" document (available in the MediaCentre).

The pressure regulator is preset at 3 bar .

Expansion options available for pilot valves.

## Technical information

Material	
End plates	Aluminum
Seal	Acrylonitrile butadiene rubber
Subbase	Die-cast aluminum

# Dimensions

## Dimensions

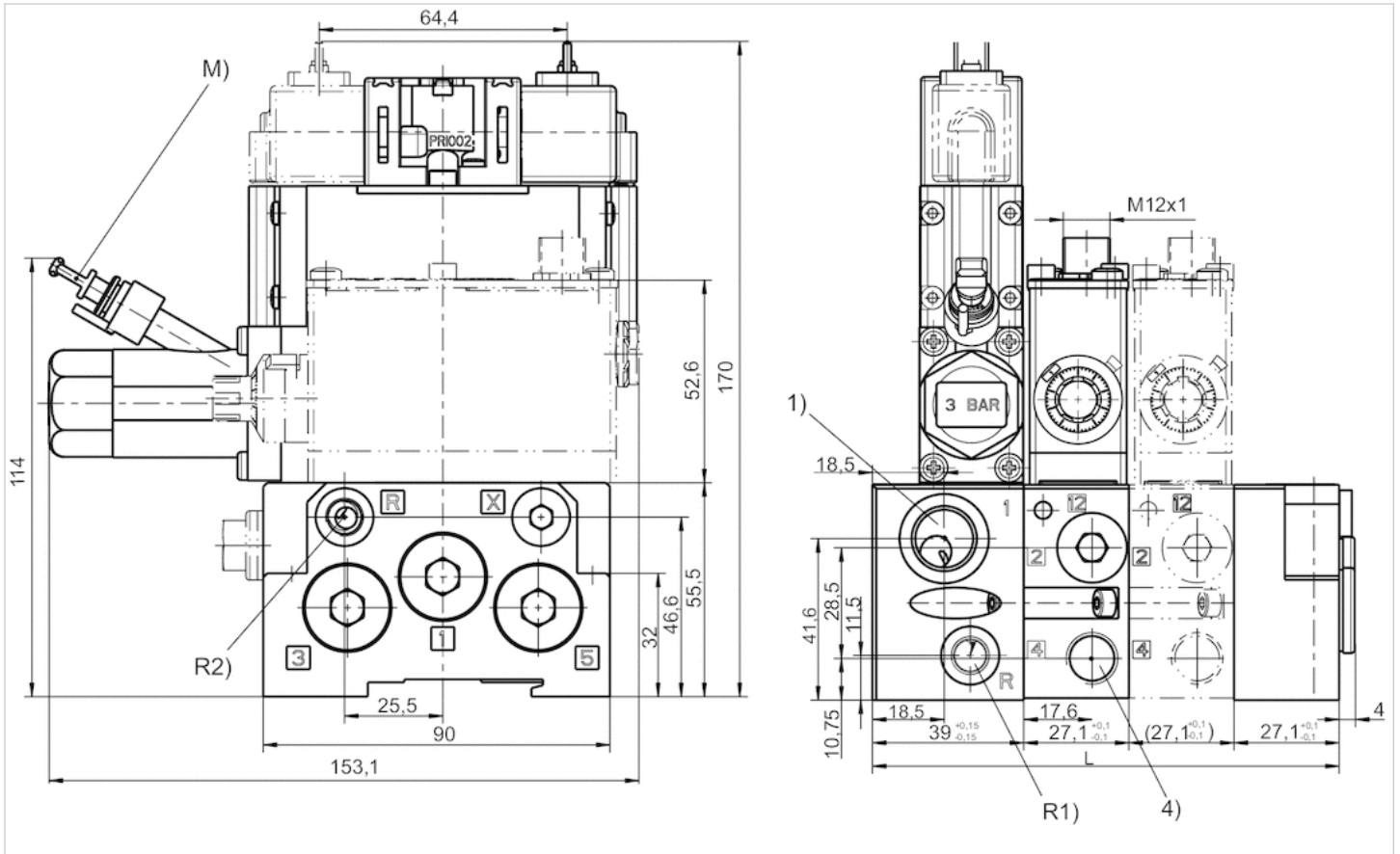

- 1) Operating pressure
- 4) Port 4 (to nozzle)
- R1) Test module exhaust/sealing air connection (max. 1 bar )
- R2) Pilot control exhaust
- M) Push-in fitting for plastic tubing Ø 6x1 of the pressure gauge
- L = length



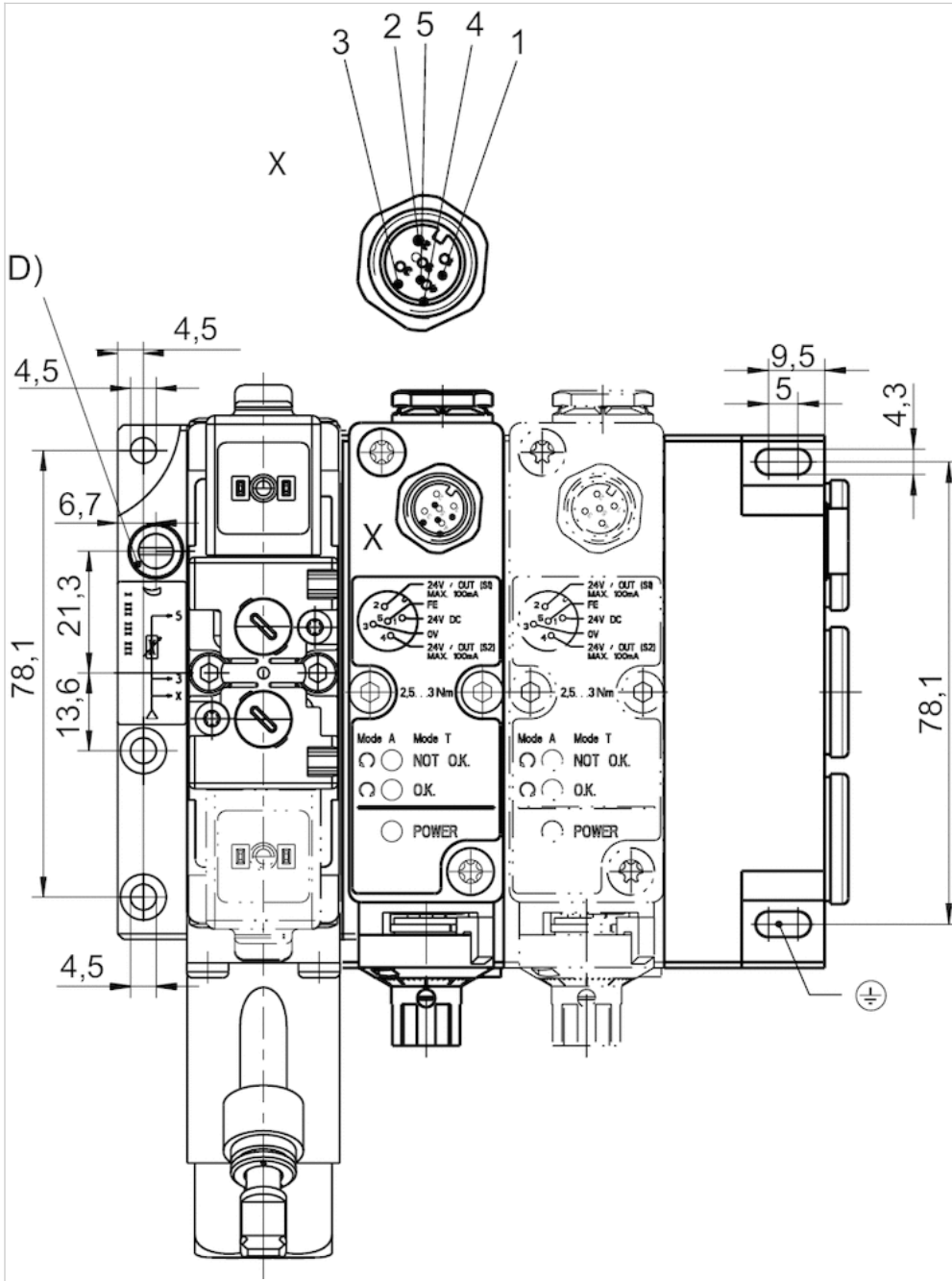

D = Throttle (cleaning pressure)

M12 contact assignment:

- contact 1: 24 V DC
- contact 2: output signal 24 V DC, S1 (working pressure), max. 100 mA
- contact 3: 0 V
- contact 4: output signal 24 V DC, S2 (testing), max. 100 mA
- contact 5: FE

Circuit diagram

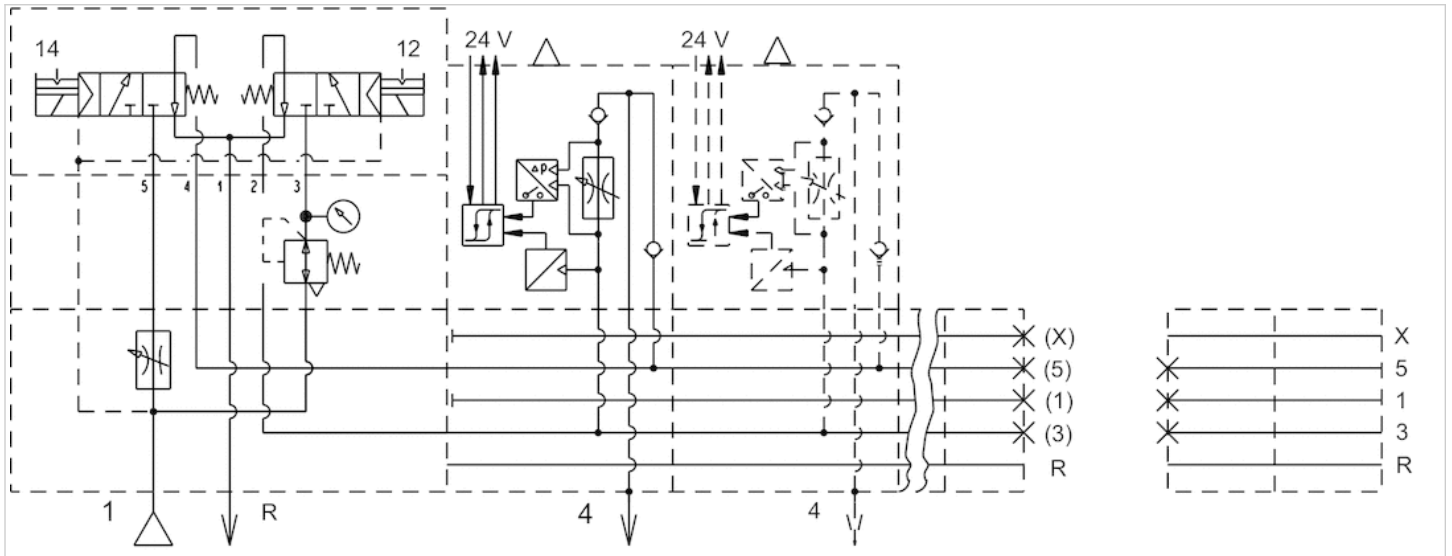

- Valve side 14: cleaning pressure
- Port 4: connection nozzle
- valve side 12: test pressure
- port R: exhaust (see dimensions for R1 and R2)

# Series MS01

- MS01-AL test block, variant II, with 5/2-directional valve
- subbase made of Die-cast aluminum
- permanent cleaning pressure



Grid dimension	27.1 mm
Standards	ISO 15407-1 26 mm
Working pressure min./max.	4 ... 10 bar
Ambient temperature min./max.	0 ... 50 °C
Medium temperature min./max.	0 ... 50 °C
Medium	Compressed air
Max. particle size	5 µm
Oil content of compressed air	0 ... 0.1 mg/m <sup>3</sup>
DC operating voltage	24 V
Voltage tolerance DC	-10% / +10%
Protection class With valve plug connector	IP65
Duty cycle	100 %
Electrical connection for valve	Plug, form C
Electr. connection	Plug, M12, 5-pin
Valve voltage tolerance	-10% / +10%
Weight	See table below

## Technical data

Part No.	Version	port pneumatic	input 1	Exhaust R1	Output 4	pilot control R2 exhaust
R412011191	1x	according to ISO 228-1	G 3/8	G 1/8	G 1/4	G 1/8
R412011192	2x	according to ISO 228-1	G 3/8	G 1/8	G 1/4	G 1/8
R412011193	3x	according to ISO 228-1	G 3/8	G 1/8	G 1/4	G 1/8
R412011194	4x	according to ISO 228-1	G 3/8	G 1/8	G 1/4	G 1/8
R412011195	5x	according to ISO 228-1	G 3/8	G 1/8	G 1/4	G 1/8
R412011196	6x	according to ISO 228-1	G 3/8	G 1/8	G 1/4	G 1/8
R412011197	7x	according to ISO 228-1	G 3/8	G 1/8	G 1/4	G 1/8
R412011198	8x	according to ISO 228-1	G 3/8	G 1/8	G 1/4	G 1/8
R412011199	1x	-	3/8 NPT	1/8 NPT	1/4 NPT	1/8 NPT
R412011200	2x	-	3/8 NPT	1/8 NPT	1/4 NPT	1/8 NPT
R412011201	3x	-	3/8 NPT	1/8 NPT	1/4 NPT	1/8 NPT
R412011202	4x	-	3/8 NPT	1/8 NPT	1/4 NPT	1/8 NPT
R412011203	5x	-	3/8 NPT	1/8 NPT	1/4 NPT	1/8 NPT
R412011204	6x	-	3/8 NPT	1/8 NPT	1/4 NPT	1/8 NPT
R412011205	7x	-	3/8 NPT	1/8 NPT	1/4 NPT	1/8 NPT
R412011206	8x	-	3/8 NPT	1/8 NPT	1/4 NPT	1/8 NPT

Part No.	Min./max. detection distance	Length	Weight
R412011191	0.01 ... 0.3 mm	93.1 mm	1.64 kg
R412011192	0.01 ... 0.3 mm	120.3 mm	2.12 kg
R412011193	0.01 ... 0.3 mm	147.4 mm	2.6 kg
R412011194	0.01 ... 0.3 mm	174.5 mm	3.07 kg
R412011195	0.01 ... 0.3 mm	201.6 mm	3.55 kg

Part No.	Min./max. detection distance	Length	Weight
R412011196	0.01 ... 0.3 mm	228.7 mm	4.03 kg
R412011197	0.01 ... 0.3 mm	255.8 mm	4.51 kg
R412011198	0.01 ... 0.3 mm	282.9 mm	4.98 kg
R412011199	0.01 ... 0.3 mm	93.1 mm	1.64 kg
R412011200	0.01 ... 0.3 mm	120.3 mm	2.12 kg
R412011201	0.01 ... 0.3 mm	147.4 mm	2.6 kg
R412011202	0.01 ... 0.3 mm	174.5 mm	3.07 kg
R412011203	0.01 ... 0.3 mm	201.6 mm	3.55 kg
R412011204	0.01 ... 0.3 mm	228.7 mm	4.03 kg
R412011205	0.01 ... 0.3 mm	255.8 mm	4.51 kg
R412011206	0.01 ... 0.3 mm	282.9 mm	4.98 kg

The detection distance is based on one measuring point per test module and depends on the operating conditions. For more information, see operating instructions.

## Technical information

The pressure dew point must be at least 15 °C under ambient and medium temperature and may not exceed 3 °C .

The oil content of compressed air must remain constant during the life cycle.

Use only the approved oils from AVENTICS. Further information can be found in the "Technical information" document (available in the MediaCentre).

The pressure regulator is preset at 3 bar .

Expansion options available for pilot valves.

## Technical information

Material	
End plates	Aluminum
Seal	Acrylonitrile butadiene rubber
Subbase	Die-cast aluminum

# Dimensions

## Dimensions

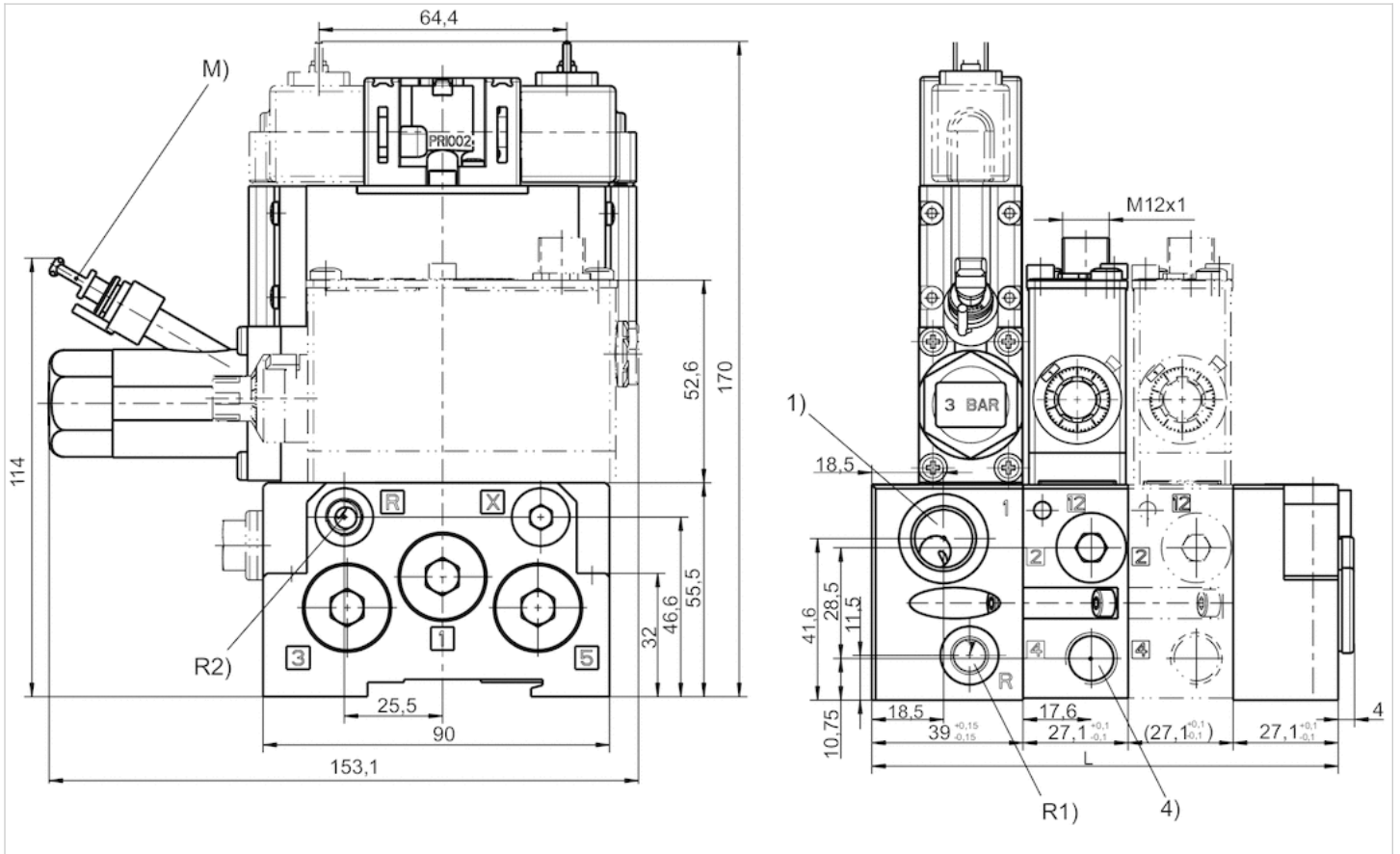

- 1) Operating pressure
- 4) Port 4 (to nozzle)
- R1) Test module exhaust/sealing air connection (max. 1 bar )
- R2) Pilot control exhaust
- M) Push-in fitting for plastic tubing Ø 6x1 of the pressure gauge
- L = length

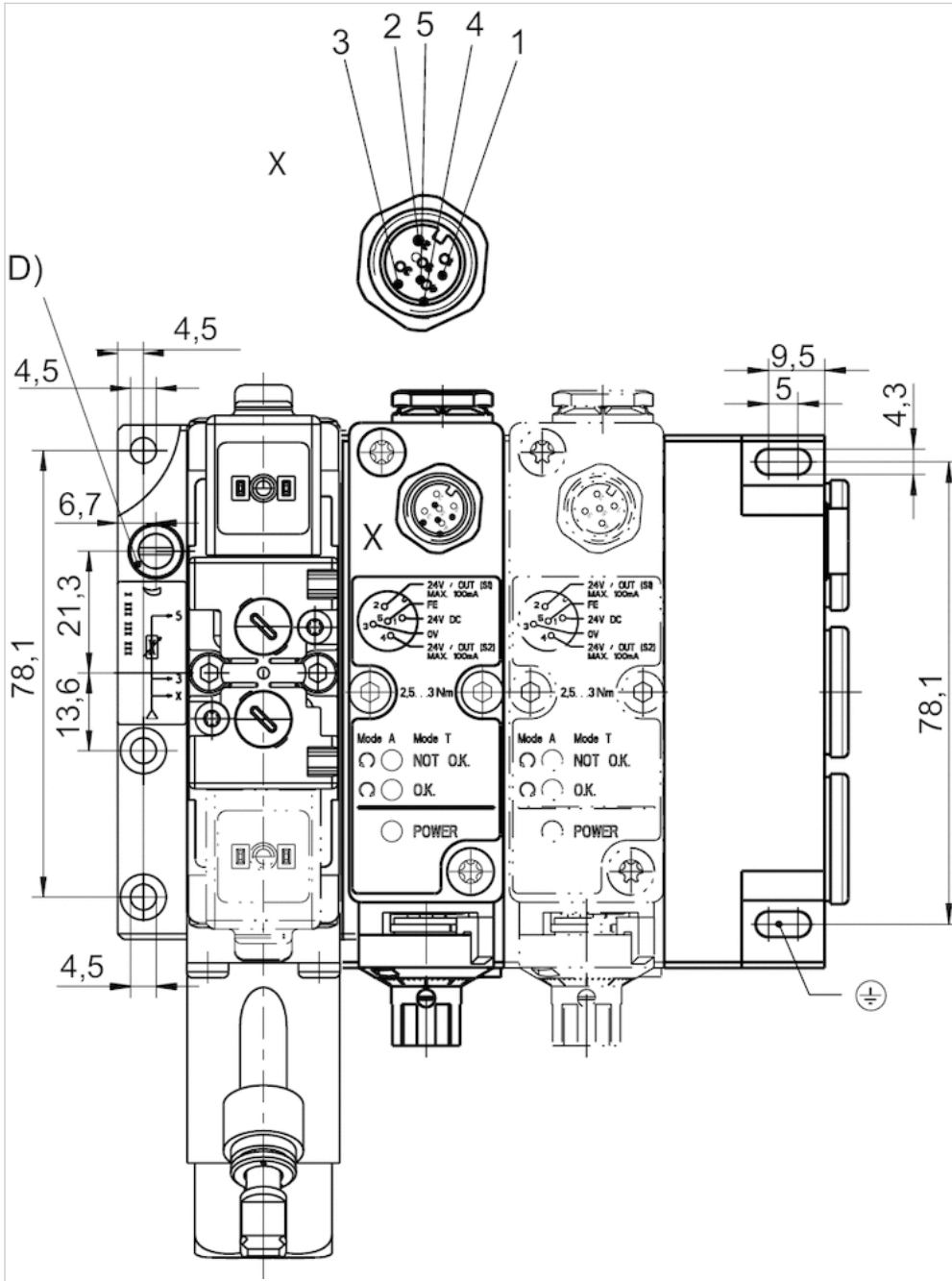

D = Throttle (cleaning pressure)

M12 contact assignment:

- contact 1: 24 V DC
- contact 2: output signal 24 V DC, S1 (working pressure), max. 100 mA
- contact 3: 0 V
- contact 4: output signal 24 V DC, S2 (testing), max. 100 mA
- contact 5: FE

Circuit diagram

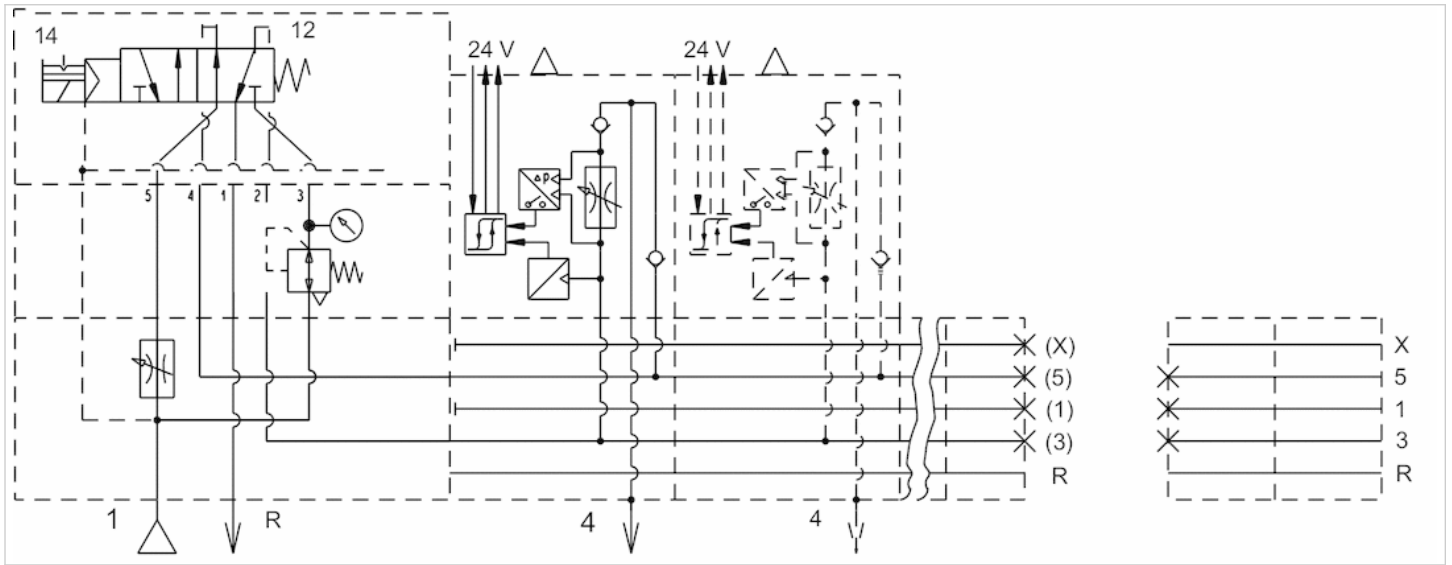

- Valve side 14: test pressure
- Port 4: connection nozzle
- valve side 12: cleaning pressure
- port R: exhaust (see dimensions for R1 and R2)

# Pressure gauge

- Back port
- Background color White
- Scale color Black, Red
- Units bar
- Units psi

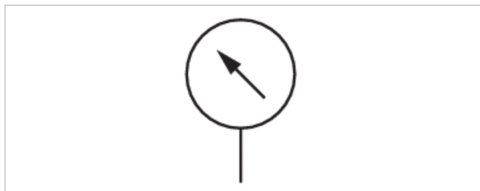

Version	Bourdon tube pressure gauge
Ambient temperature min./max.	-15 ... 80 °C
Medium	Compressed air
Max. particle size	50 µm
Oil content of compressed air	0 ... 5 mg/m <sup>3</sup>
Main scale unit (outside)	bar
Main scale color (outside)	Black
Secondary scale unit (inside)	psi
Secondary scale color (inside)	Red
Background color	White
Pointer color	Black
Weight	0.016 kg
	The delivered product may vary from that in the illustration.

## Technical data

Part No.	Compressed air connection	Nominal diameter	Range of application	Display range	Operating pressure
R412003960	Ø 6	28 mm	0 ... 4	0 bar ... 4	0 ... 4 bar
3530200300	Ø 6	28 mm	0 ... 10	0 bar ... 10 bar	0 ... 10 bar

Included in the delivery contents: Straight push-in fitting, increasing (1823391628)

## Technical information

Material	
Housing	Polyamide



## Dimensions

### Dimensions in mm

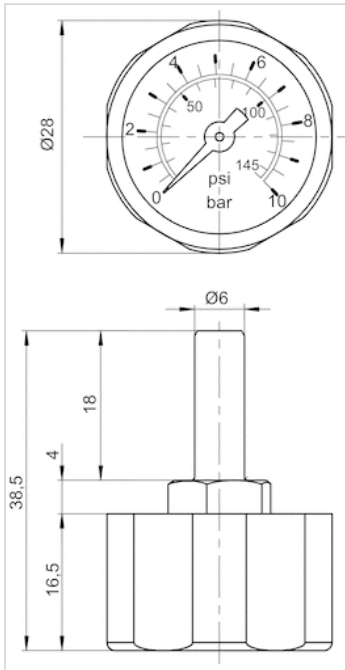

# 2x3/2-directional valve, Series CD01-PA

- ISO 15407-1
- 26 mm
- 2x3/2
- NO/NO
- Compressed air connection output base plate DIN ISO 15407-1
- Electrical connection Plug, EN 175301-803, form C
- Manual override with detent

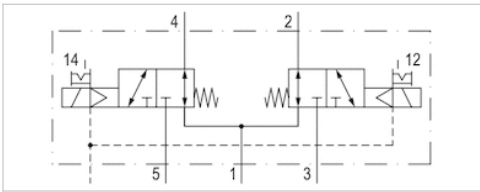

Version	Spool valve, positive overlapping
Pilot	External
Sealing principle	Soft sealing
Connection type	Plate connection
Standards	ISO 15407-1, 26 mm
Connector standard	EN 175301-803, form C
Certificates	Free of substances that impair surface wetting in the coating process
Working pressure min./max.	0 ... 16 bar
Control pressure min./max.	10 bar
Ambient temperature min./max.	-15 ... 50 °C
Medium temperature min./max.	-15 ... 50 °C
Medium	Compressed air
Max. particle size	50 µm
Oil content of compressed air	0 ... 5 mg/m <sup>3</sup>
Compressed air connection	according to ISO 15407-1
Protection class with connection	IP65
Duty cycle	100 %
Typ. switch-on time	26 ms
Typ. switch-off time	34 ms
Mounting screw	M4 with hexagon socket
Mounting screw tightening torque	2.5 Nm
Weight	0.25 kg

## Technical data

Part No.	MO	Operational voltage DC	Voltage tolerance DC
5763960220	NO/NO 	24 V	-10% / +10%

Part No.	Power consumption DC	Nominal flow 1 ► 2	Nominal flow 2 ► 3
5763960220	1.6 W	800 l/min	700 l/min

Part No.	Electrical connection Pilot valve
5763960220	Plug EN 175301-803, form C

Nominal flow Q<sub>n</sub> at 6 bar and Δp = 1 bar, MO = Manual override

External control pressure: see diagram

## Technical information

The min. control pressure must be adhered to, since otherwise faulty switching and valve failure may result!

The pressure dew point must be at least 15 °C under ambient and medium temperature and may not exceed 3 °C .

The oil content of compressed air must remain constant during the life cycle.

Use only the approved oils from AVENTICS. Further information can be found in the “Technical information” document (available in the MediaCentre).

Versions with voltage of less than 50 V DC do not have a protective ground.

## Technical information

Housing	Polyamide Polyoxymethylene
Seals	Acrylonitrile butadiene rubber

# Dimensions

## Dimensions

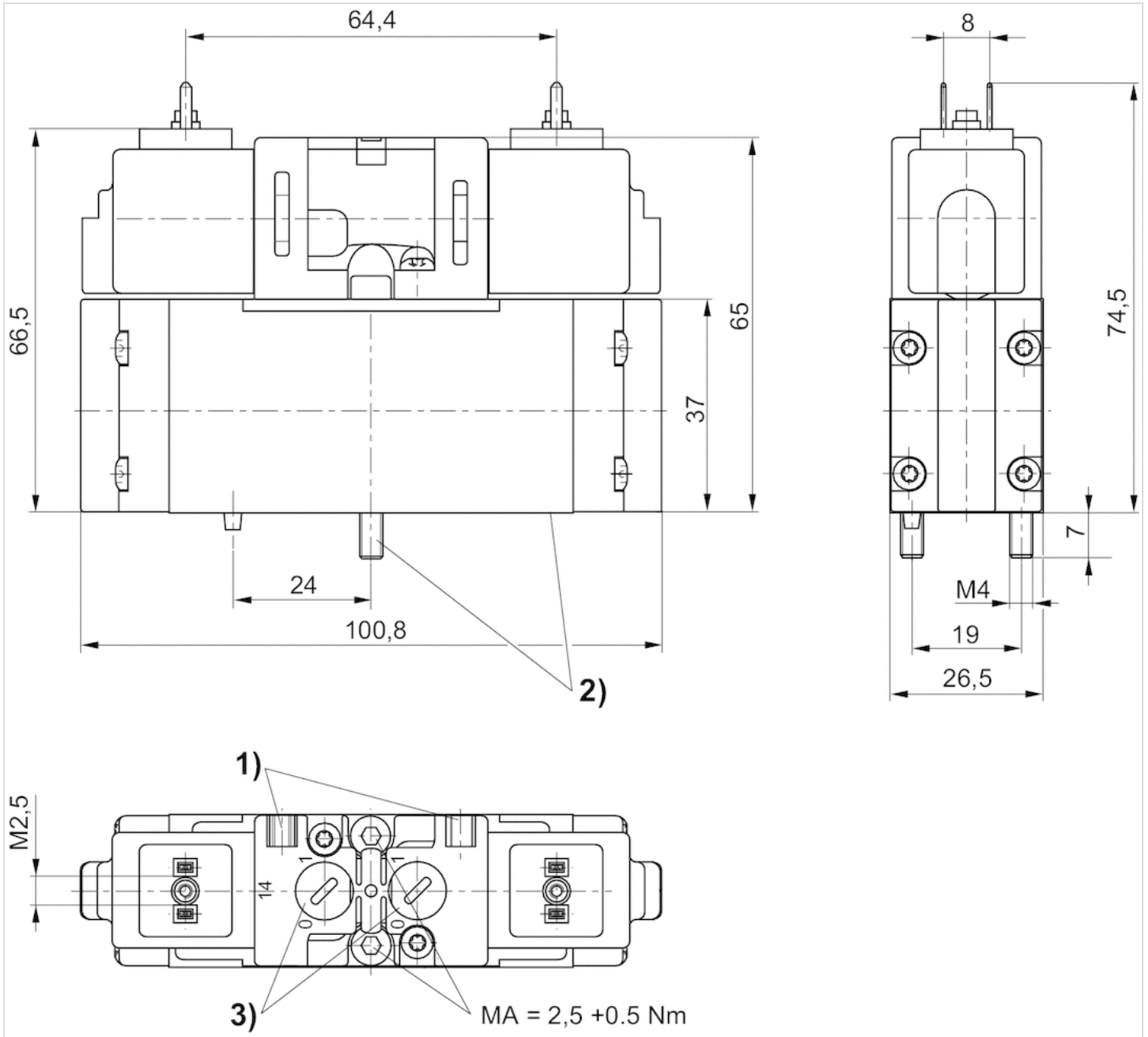

1) mounting space for name plate 2) screws and seals captive 3) manual override

## Diagrams

Minimum control pressure for externally piloted valves (depending on the working pressure)

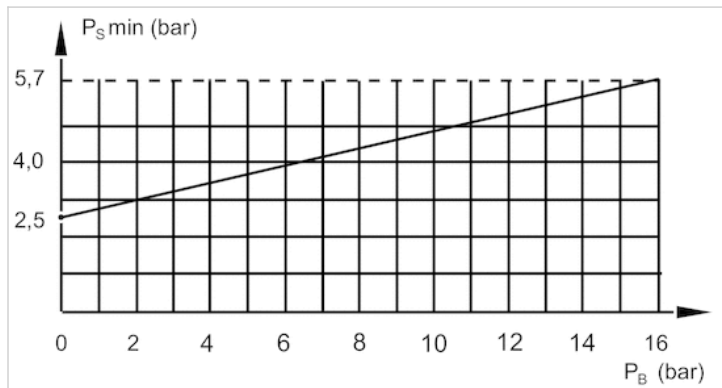

PB= Working pressure

PS = control pressure

# Base plate

- standard ISO 15407-1
- Frame size 26 mm
- type A
- Compressed air connection output G 1/4 Ø 10x1
- Can be assembled into blocks
- Single base plate principle
- Reversed pressure supply permissible
- With collective pilot air exhaust



Standards	ISO 15407-1
Compressed air connection	according to ISO 15407-1
Working pressure min./max.	-0.95 ... 16 bar
Ambient temperature min./max.	-15 ... 70 °C
Medium temperature min./max.	-15 ... 70 °C
Medium	Compressed air
Number of valve positions max.	1
Grid dimension	27.1 mm
Exhaust (3,5)	With directional exhaust (3/5)
Exhaust type	Ports separated
Mounting screw	with hexagon socket
Tightening torque for mounting screws	4 Nm
Weight	0.195 kg

## Technical data

Part No.	Type	Compressed air connection Output [2 / 4]	Compressed air connection Pilot connection [X]
1825504023	C1	G 1/4	-
1825504025	C1	Ø 10x1	-
1825504026	C2	G 1/4	M5
1825504029	C3	G 1/4	-
1825504030	C4	G 1/4	M5

Part No.	Compressed air connection Pilot control exhaust [R]	Connection direction
1825504023	-	On the side
1825504025	-	On the side
1825504026	M5	On the side
1825504029	-	Down
1825504030	M5	Down

Scope of delivery incl. seal and mounting screws

## Technical information

The min. control pressure must be adhered to, since otherwise faulty switching and valve failure may result!  
 The pressure dew point must be at least 15 °C under ambient and medium temperature and may not exceed 3 °C .  
 The oil content of compressed air must remain constant during the life cycle.  
 Use only the approved oils from AVENTICS. Further information can be found in the “Technical information” document (available in the MediaCentre).

## Technical information

Material	
Base plate	Die-cast aluminum
Seal	Acrylonitrile butadiene rubber

## Dimensions

### Overview drawing

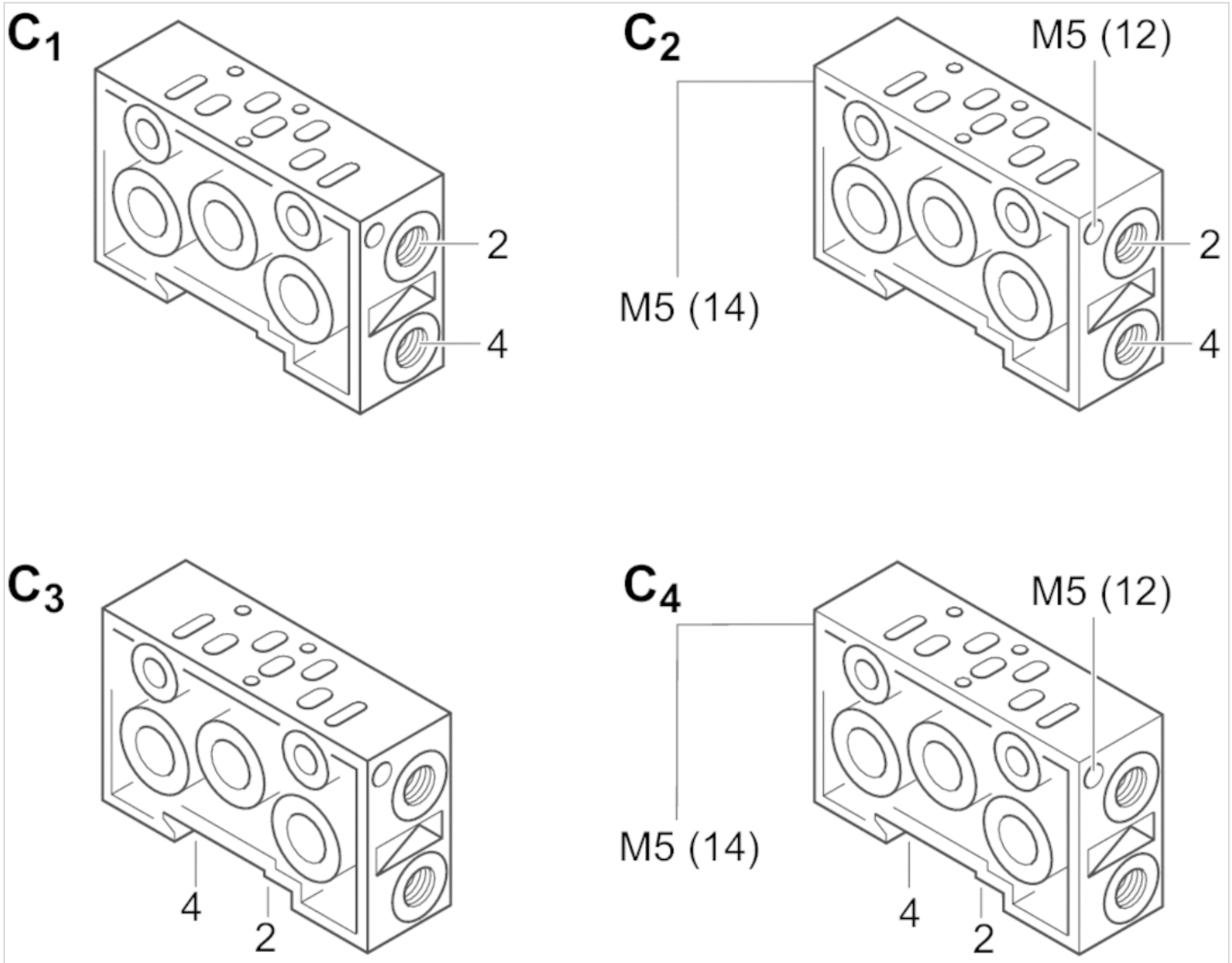

Dimensions

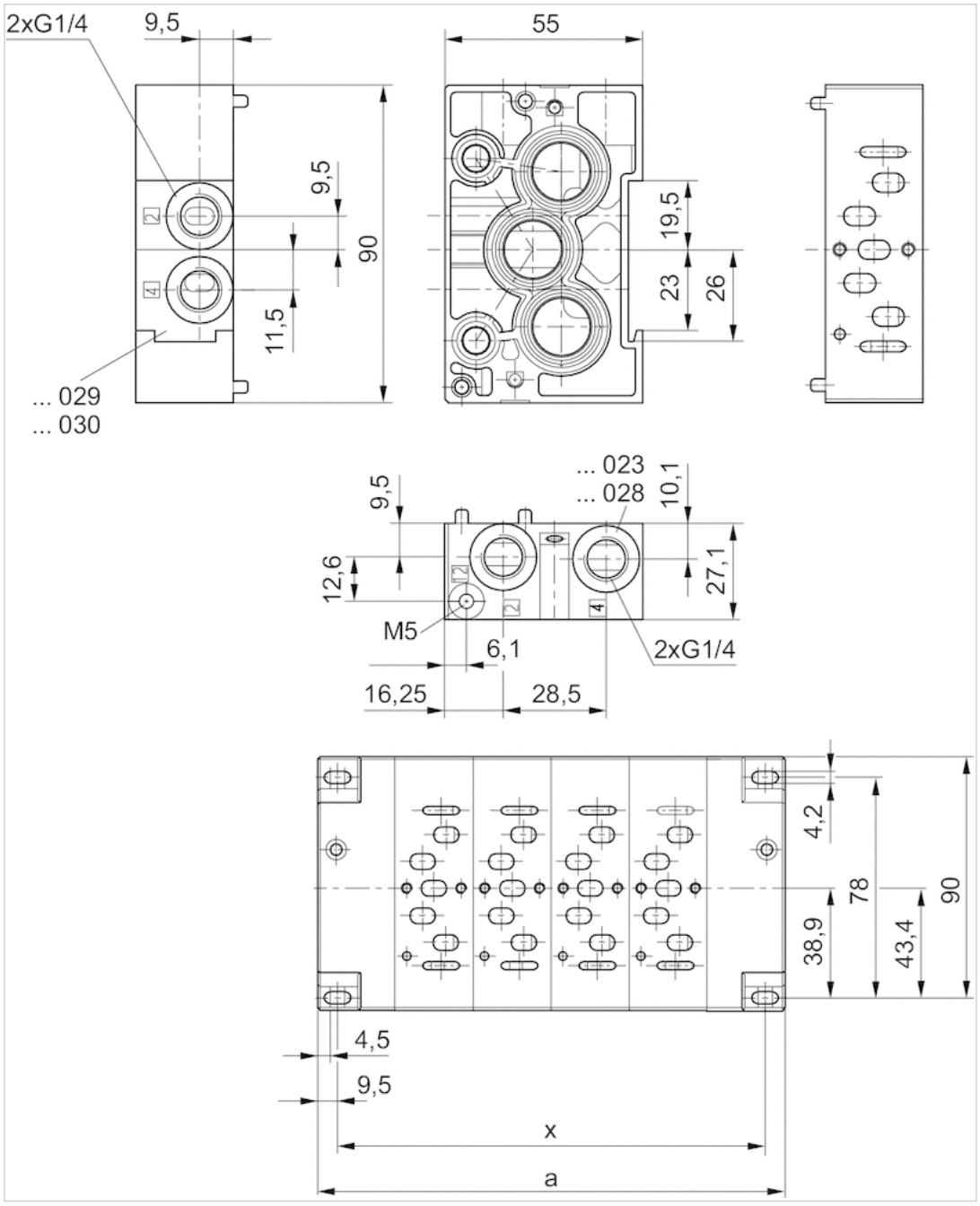



# End plate left, End plate right

- standard ISO 15407-1
- Frame size 26 mm
- type A
- Can be assembled into blocks
- Base plate principle, multiple
- Reversed pressure supply permissible
- With collective pilot air exhaust



Standards	ISO 15407-1
Working pressure min./max.	-0.95 ... 16 bar
Ambient temperature min./max.	-15 ... 70 °C
Medium temperature min./max.	-15 ... 70 °C
Medium	Compressed air
Grid dimension	27.1 mm
Direction of pneumatic port (1)	On the side
Direction of pneumatic port (3,5)	On the side
Direction of pneumatic port (12)	On the side
Direction of pneumatic port (14)	On the side
Exhaust (3,5)	With directional exhaust (3/5)
Exhaust type	Ports separated
Mounting screw	with hexagon socket
Tightening torque for mounting screws	4 Nm

## Technical data

Part No.	Compressed air connection Input [1]	Compressed air connection Exhaust [3 / 5]
1825504031	G 3/8	G 3/8

Part No.	Compressed air connection Pilot connection [X]	Compressed air connection Pilot control exhaust [R]
1825504031	G 1/8	G 1/8

Scope of delivery: end plate kit incl. seal and mounting screws

## Technical information

The min. control pressure must be adhered to, since otherwise faulty switching and valve failure may result!  
 The pressure dew point must be at least 15 °C under ambient and medium temperature and may not exceed 3 °C .  
 The oil content of compressed air must remain constant during the life cycle.  
 Use only the approved oils from AVENTICS. Further information can be found in the "Technical information" document (available in the MediaCentre).

## Technical information

Material	
Base plate	Die-cast aluminum
Seal	Acrylonitrile butadiene rubber

Dimensions

Dimensions

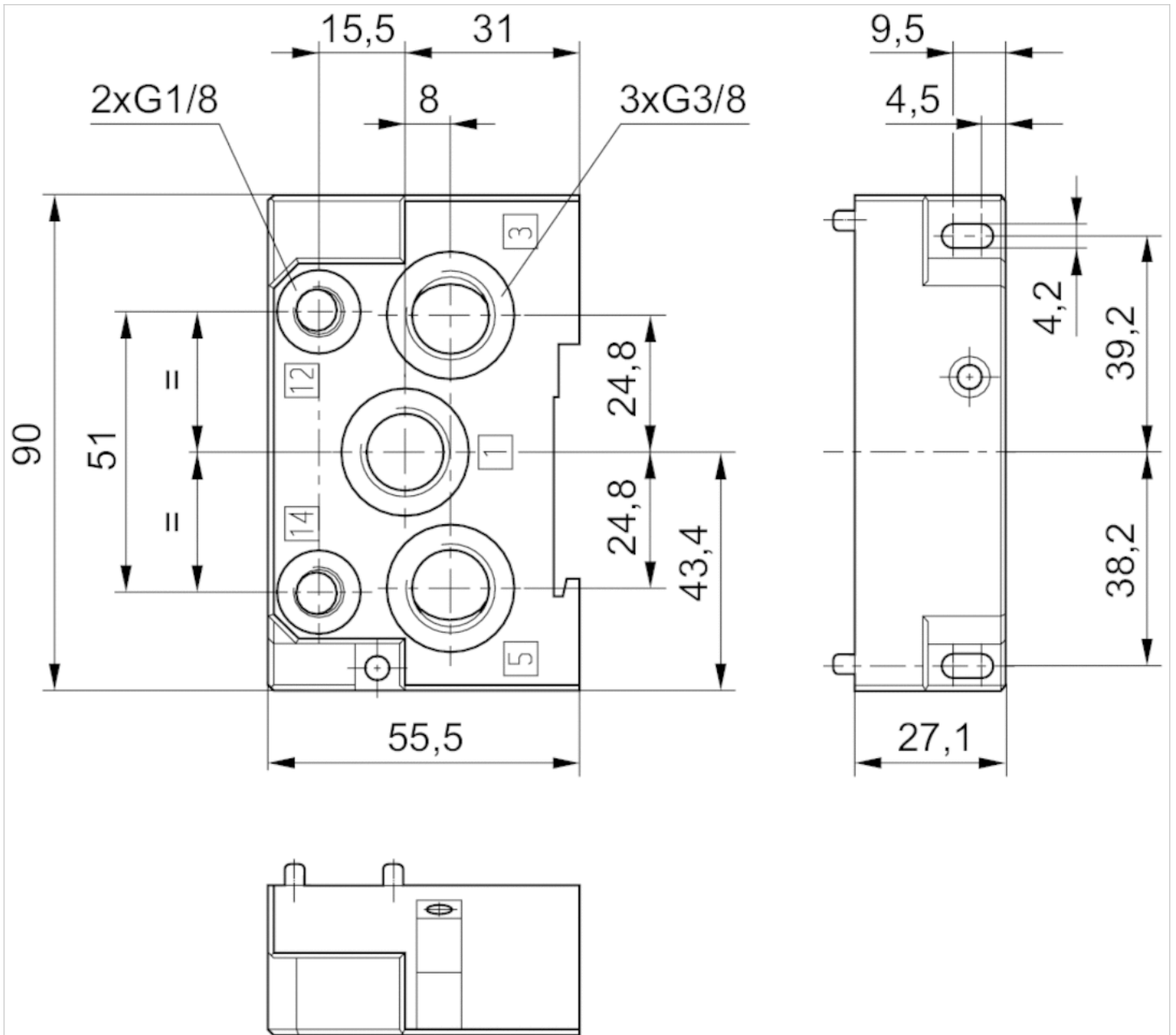

# Round plug connector, Series CON-RD

- Socket M12x1 5-pin A-coded straight 180°
- Plug M12x1 5-pin A-coded straight 180°
- for DDL
- with cable
- shielded



Ambient temperature min./max.	-25 ... 80 °C
Operational voltage	30 / 36 V AC/DC
Protection class	IP67
Wire cross-section	0.34 mm <sup>2</sup>
Weight	See table below

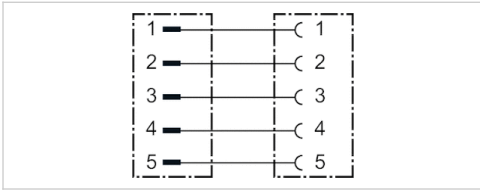

## Technical data

Part No.	Max. current	Number of wires	Bending radius min.	Cable-Ø	Cable length	Weight
8946054662	4 A	5	45 mm	6 mm	0.3 m	0.051 kg
8946054672	4 A	5	45 mm	6 mm	0.5 m	0.051 kg
8946054682	4 A	5	45 mm	6 mm	1 m	0.088 kg
8946054692	4 A	5	45 mm	6 mm	2 m	0.139 kg
8946054702	4 A	5	45 mm	6 mm	5 m	0.289 kg
8946054712	4 A	5	45 mm	6 mm	10 m	0.536 kg

## Technical information

The specified protection class is only valid in assembled and tested state.

## Technical information

Material	
Housing	Polyurethane
Seals	Fluorocaoutchouc
Cable sheath	Polyurethane

## Dimensions

### Dimensions

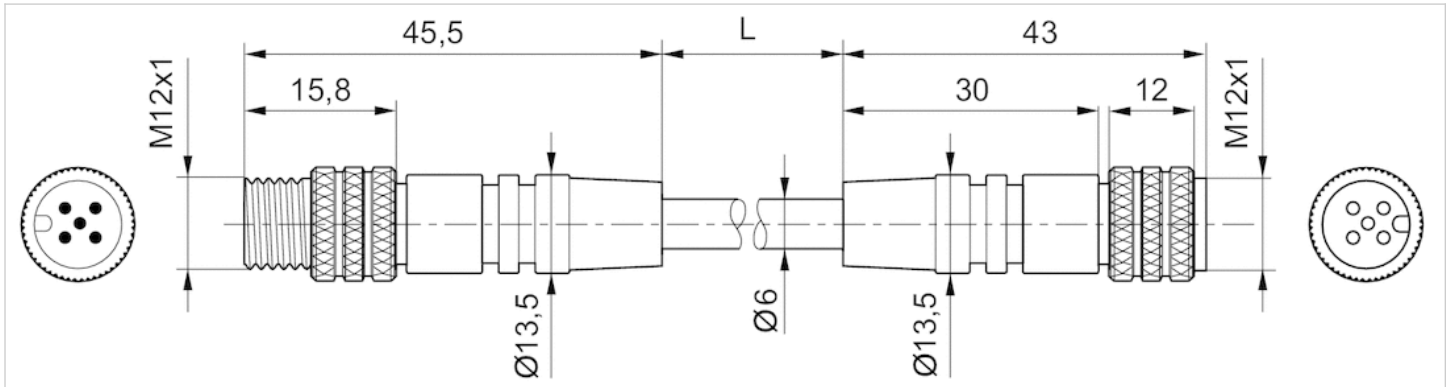

L = cable length

## Pin assignments

### Pin assignment, socket

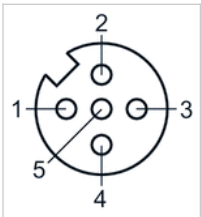

### Plug pin assignment

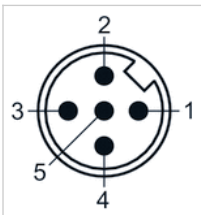

# Base plate, ports 2 and 4 on side

- standard ISO 15407-1
- Frame size 26 mm
- type B
- Compressed air connection output Ø 6x1
- Can be assembled into blocks
- Single base plate principle
- Reversed pressure supply permissible

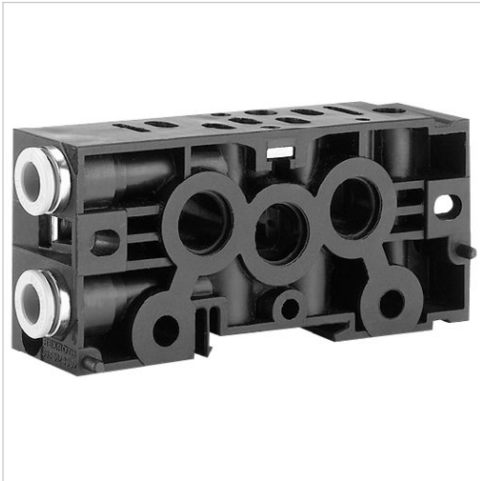

Standards	ISO 15407-1
Compressed air connection	according to ISO 15407-1
Working pressure min./max.	-0.95 ... 16 bar
Ambient temperature min./max.	-25 ... 70 °C
Medium temperature min./max.	-25 ... 70 °C
Medium	Compressed air
Number of valve positions max.	1
Grid dimension	27 mm
Direction of pneumatic port (3,5)	On the side
Direction of pneumatic port (2,4)	On the side
Exhaust (3,5)	With directional exhaust (3/5)
Exhaust type	Ports separated
Mounting screw	with hexagon socket
Tightening torque for mounting screws	4 Nm
Weight	0.13 kg

## Technical data

Part No.	Compressed air connection Output [2 / 4]
8985121122	Ø 6x1

Scope of delivery incl. seal and mounting screws

## Technical information

The min. control pressure must be adhered to, since otherwise faulty switching and valve failure may result!

The pressure dew point must be at least 15 °C under ambient and medium temperature and may not exceed 3 °C .

The oil content of compressed air must remain constant during the life cycle.

Use only the approved oils from AVENTICS. Further information can be found in the "Technical information" document (available in the MediaCentre).

## Technical information

Material	
Base plate	Polyamide fiber-glass reinforced
Seal	Acrylonitrile butadiene rubber

# Dimensions

## Dimensions

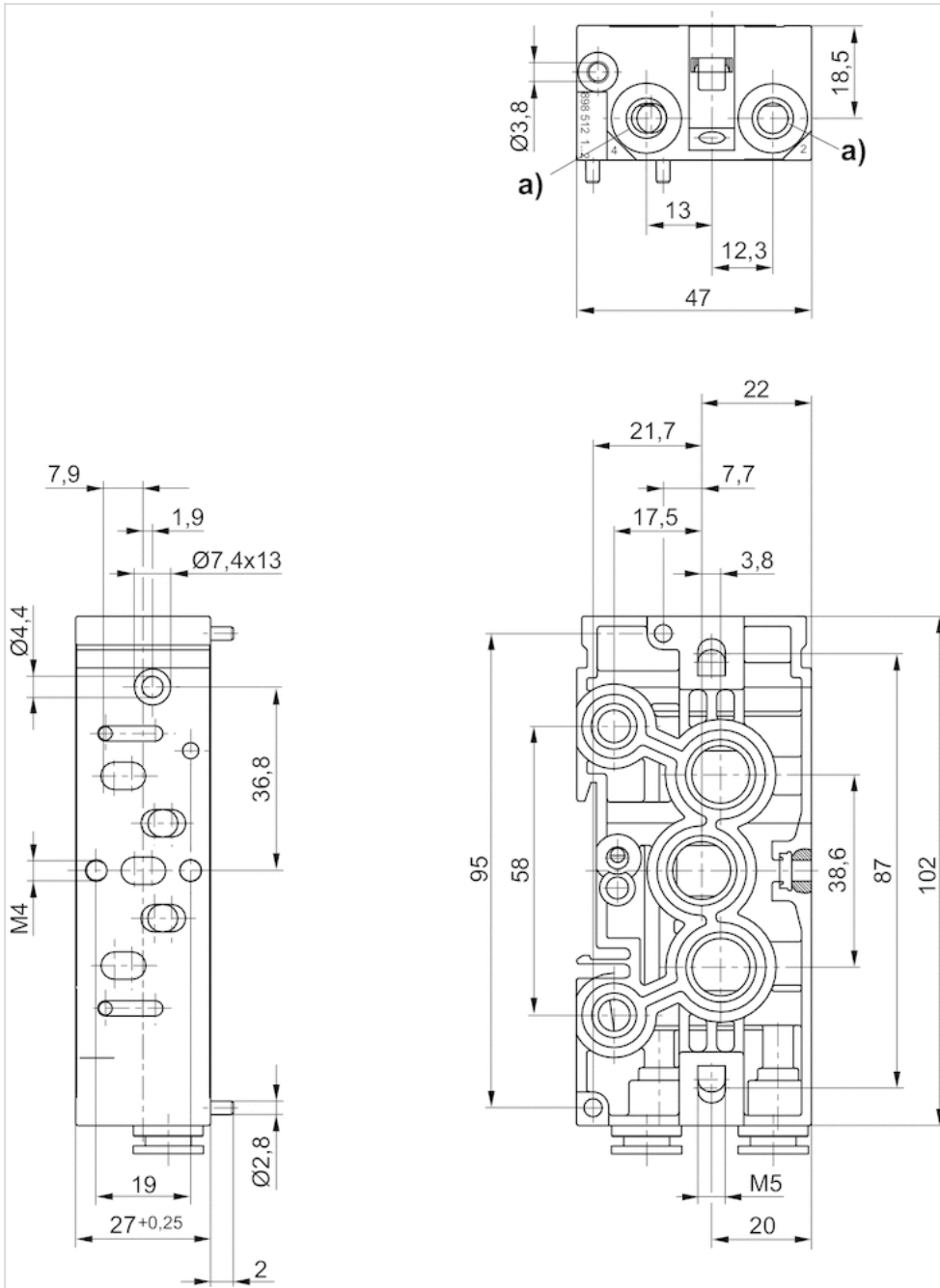

a) push-in fitting or thread connection

# 5/2-directional valve, Series CD01-PA

- ISO 15407-1
- 26 mm
- 5/2
- With spring/air spring return
- single solenoid
- $Q_n = 1010 \text{ l/min}$
- Compressed air connection output base plate DIN ISO 15407-1
- Electrical connection Plug, EN 175301-803, form C
- Manual override with detent

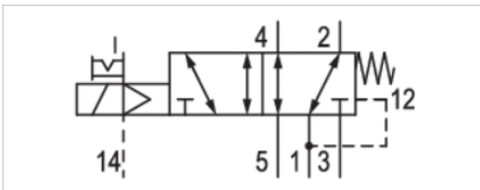

Version	Spool valve, positive overlapping
Pilot	External
Sealing principle	Soft sealing
Connection type	Plate connection
Standards	ISO 15407-1, 26 mm
Connector standard	EN 175301-803, form C
Certificates	Free of substances that impair surface wetting in the coating process
Working pressure min./max.	0 ... 16 bar
Control pressure min./max.	3 ... 10 bar
Ambient temperature min./max.	-15 ... 50 °C
Medium temperature min./max.	-15 ... 50 °C
Medium	Compressed air
Max. particle size	50 $\mu\text{m}$
Oil content of compressed air	0 ... 5 $\text{mg/m}^3$
Nominal flow $Q_n$	1010 l/min
Compressed air connection	according to ISO 15407-1
Protection class with connection	IP65
Duty cycle	100 %
Typ. switch-on time	34 ms
Typ. switch-off time	35 ms
Mounting screw	M4 with hexagon socket
Mounting screw tightening torque	2.5 Nm
Weight	0.21 kg

## Technical data

Part No.	MO	Operational voltage DC	Voltage tolerance DC	Power consumption DC
5763600220		24 V	-10% / +10%	1.6 W

Part No.	Nominal flow 1 $\triangleright$ 2	Nominal flow 2 $\triangleright$ 3	Electrical connection Pilot valve
5763600220	1010 l/min	1010 l/min	Plug EN 175301-803, form C

Nominal flow  $Q_n$  at 6 bar and  $\Delta p = 1 \text{ bar}$ , MO = Manual override

Control pressure: see diagram for min., max. 10 bar

## Technical information

The min. control pressure must be adhered to, since otherwise faulty switching and valve failure may result!

The pressure dew point must be at least 15 °C under ambient and medium temperature and may not exceed 3 °C .

The oil content of compressed air must remain constant during the life cycle.

Use only the approved oils from AVENTICS. Further information can be found in the “Technical information” document (available in the MediaCentre).

Versions with voltage of less than 50 V DC do not have a protective ground.

## Technical information

Housing	Polyamide Polyoxymethylene
Seals	Acrylonitrile butadiene rubber



# Dimensions

## Dimensions

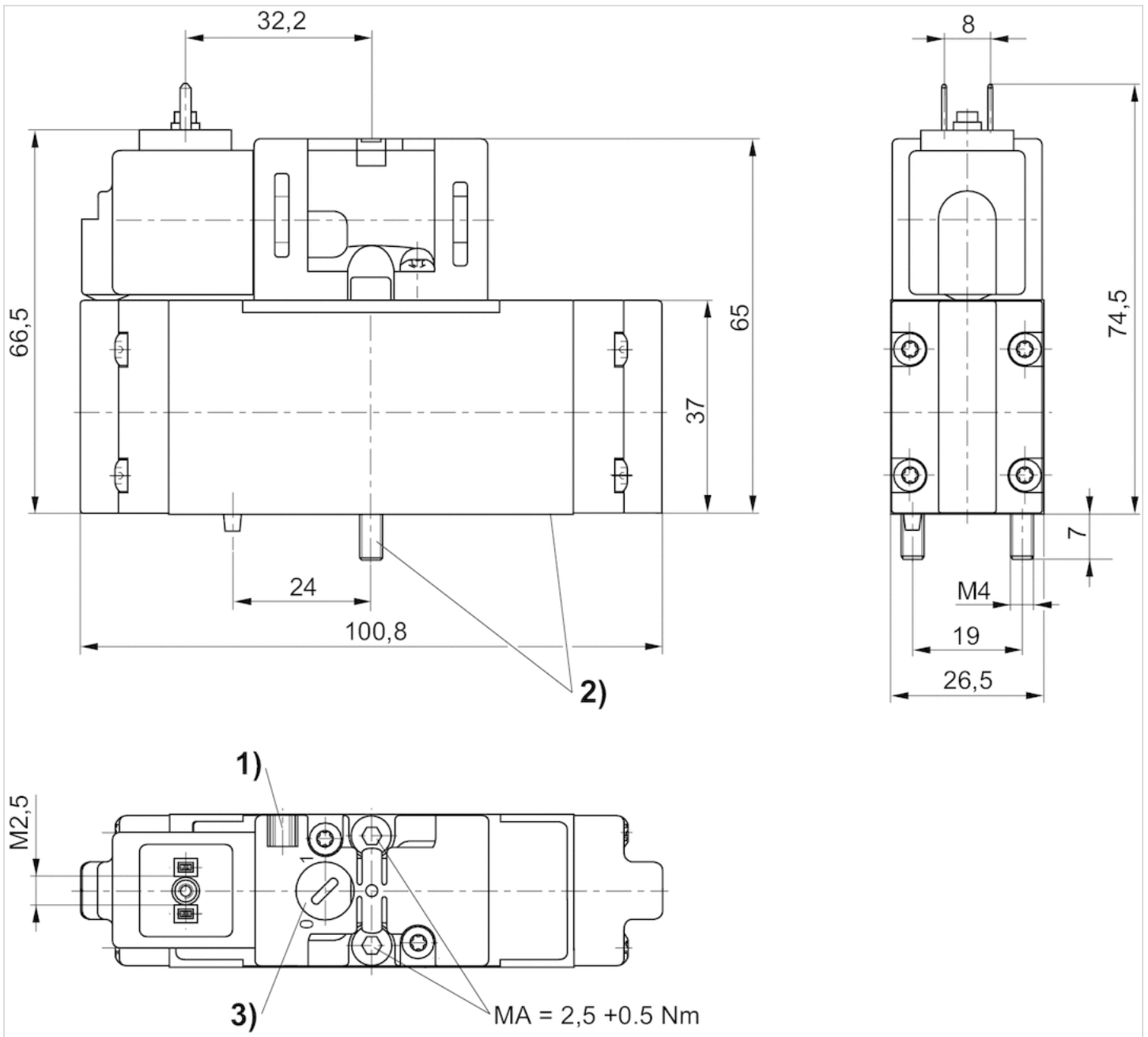

1) mounting space for name plate 2) screws and seals captive 3) manual override

## Diagrams

Minimum control pressure for externally piloted valves (depending on the working pressure)

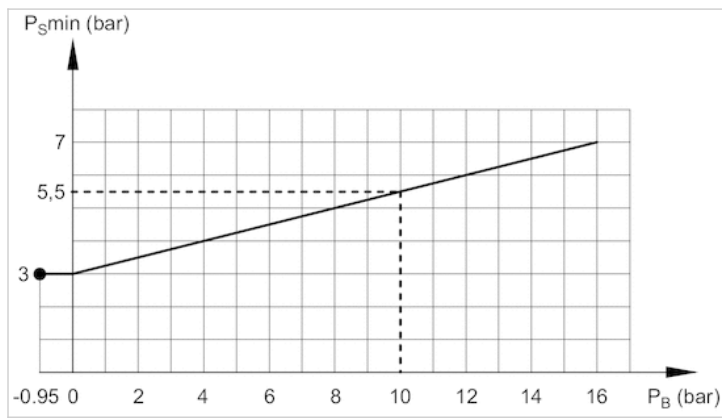

$P_B$  = Working pressure

$P_S$  = control pressure

# Blanking screw, gasket

- G 3/8 G 1/8

- FPT-S-RBI



Working pressure min./max.

0 ... 16 bar

Ambient temperature min./max.

-20 ... 80 °C

The delivered product may vary from that in the illustration.

## Technical data

Part No.	Port G	Delivery unit
1823462030	G 3/8	25 piece
1823462028	G 1/8	25 piece

## Technical information

Material	
Material	Steel, galvanized
Seal	Polyvinyl chloride, hard

## Dimensions

### Dimensions

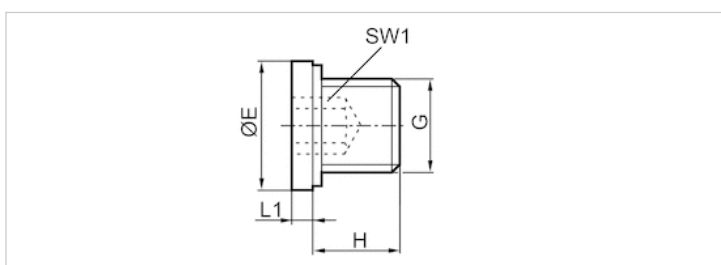

## Dimensions

Port G	Ø E	H	L1	SW1
G 3/8	22	12	3	8
G 1/8	14	8	3	5

# Supply plate

- standard ISO 15407-1
- Frame size 26 mm
- Can be assembled into blocks
- Base plate principle, multiple
- Reversed pressure supply permissible
- With collective pilot air exhaust
- for MS01-PA



Standards	ISO 15407-1
Compressed air connection	according to ISO 15407-1
Working pressure min./max.	-0.95 ... 16 bar
Ambient temperature min./max.	-25 ... 70 °C
Medium temperature min./max.	-25 ... 70 °C
Medium	Compressed air
Number of valve positions max.	1
Grid dimension	39 mm
Direction of pneumatic port (1)	On the side
Direction of pneumatic port (3,5)	On the side
Direction of pneumatic port (2,4)	Up
Direction of pneumatic port (12)	On the side
Direction of pneumatic port (14)	On the side
Exhaust (3,5)	With directional exhaust (3/5)
Exhaust type	Ports separated
Mounting screw	with hexagon socket
Tightening torque for mounting screws	4 Nm
Weight	0.41 kg

## Technical data

Part No.	Compressed air connection Input [1]	Compressed air connection Exhaust [3 / 5]
8985121502	G 3/8	G 1/8

Part No.	Compressed air connection Pilot control exhaust [R]
8985121502	G 1/8

## Technical information

The min. control pressure must be adhered to, since otherwise faulty switching and valve failure may result!  
 The pressure dew point must be at least 15 °C under ambient and medium temperature and may not exceed 3 °C .  
 The oil content of compressed air must remain constant during the life cycle.  
 Use only the approved oils from AVENTICS. Further information can be found in the "Technical information" document (available in the MediaCentre).

## Technical information

Material

Base plate

Aluminum

## Dimensions

Dimensions

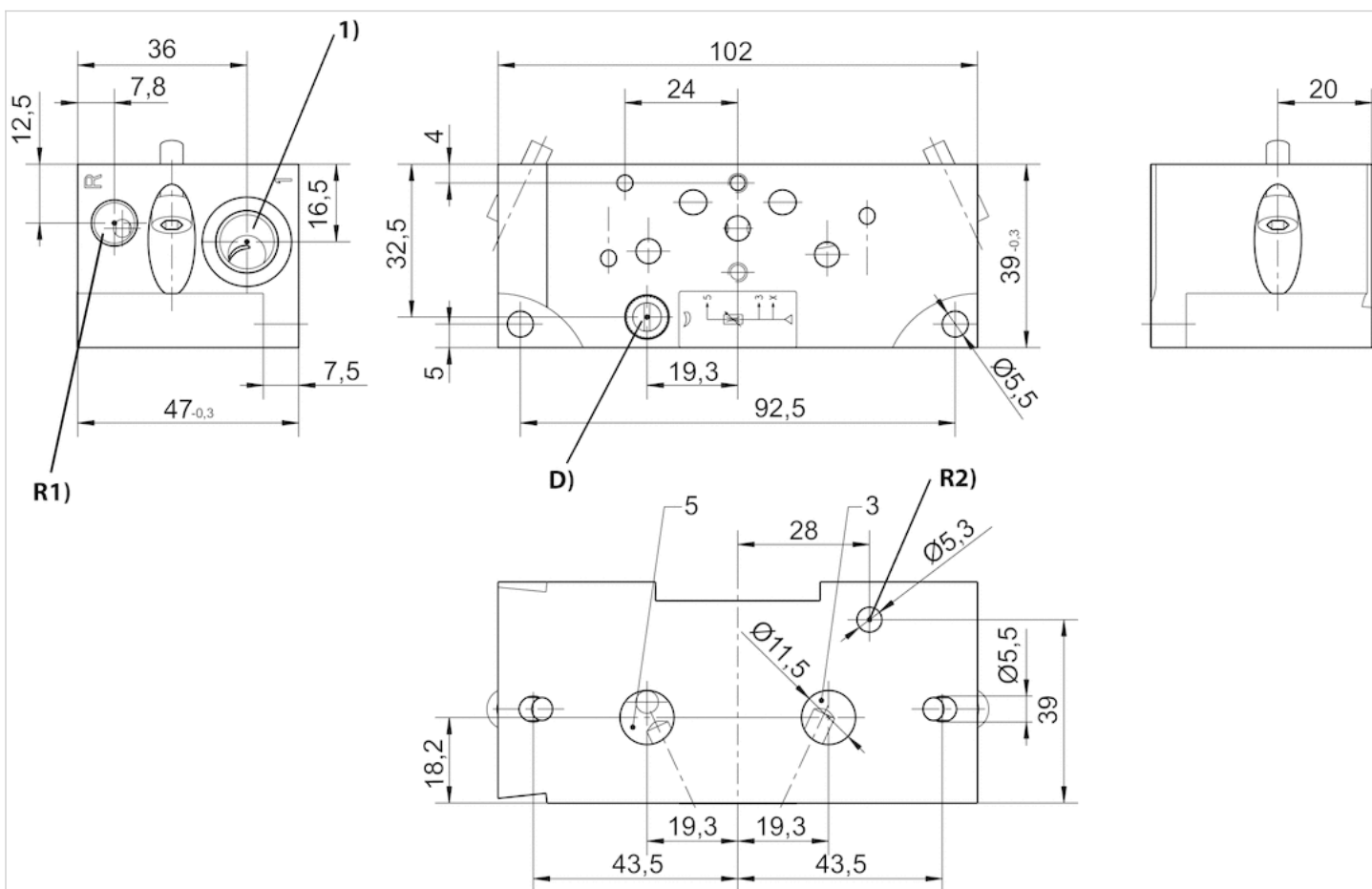

1) Operating pressure

D = Throttle (cleaning pressure)

R1) Test module exhaust/sealing air connection (max. 1 bar )

R2) Pilot control exhaust

# Separator

- for MS01-AL, CD01-PA
- standard ISO 15407-1, 26 mm
- type A



Standards	ISO 15407-1
Working pressure min./max.	-0.95 ... 16 bar
Ambient temperature min./max.	-15 ... 50 °C
Weight	See table below

## Technical data

Part No.	Type	Accessory type	Frame size	Weight
1820220039	Separator for connections 1, 3, 5	type A	26 mm	0.004 kg
1820220040	For connections 12 and 14	type A	26 mm	0.002 kg

## Technical information

Material	
Housing	Aluminum
Seal	Acrylonitrile butadiene rubber

## Dimensions

### Dimensions

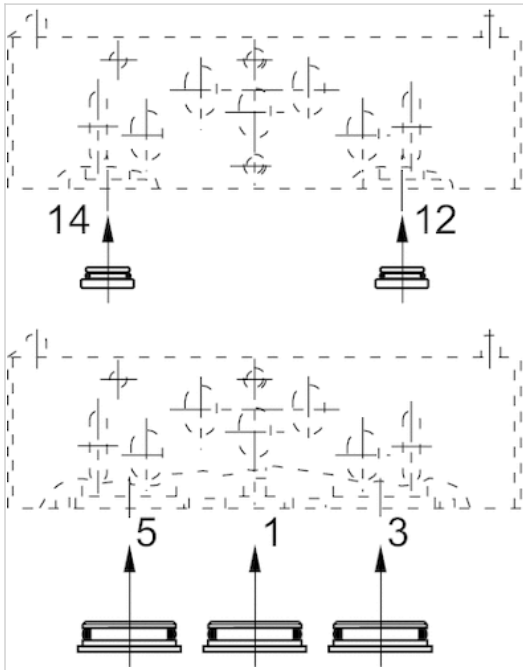

# Supply plate

- standard ISO 15407-1
- Frame size 26 mm
- Can be assembled into blocks
- Base plate principle, multiple
- Reversed pressure supply permissible
- With collective pilot air exhaust
- for MS01-AL



Standards	ISO 15407-1
Compressed air connection	according to ISO 15407-1
Working pressure min./max.	-0.95 ... 16 bar
Ambient temperature min./max.	-25 ... 70 °C
Medium temperature min./max.	-25 ... 70 °C
Medium	Compressed air
Number of valve positions max.	1
Grid dimension	39 mm
Direction of pneumatic port (1)	On the side
Direction of pneumatic port (3,5)	On the side
Direction of pneumatic port (2,4)	Up
Direction of pneumatic port (12)	On the side
Direction of pneumatic port (14)	On the side
Exhaust (3,5)	With directional exhaust (3/5)
Exhaust type	Ports separated
Mounting screw	with hexagon socket
Tightening torque for mounting screws	4 Nm
Weight	435 kg

## Technical data

Part No.	Compressed air connection	Compressed air connection
	Input [1]	Exhaust [3 / 5]
R412009674	G 3/8	G 1/8
R412009781	3/8-18 NPTF	1/8 NPT

Part No.	Compressed air connection Pilot control exhaust [R]
R412009674	G 1/8
R412009781	1/8-27 NPTF

## Technical information

The min. control pressure must be adhered to, since otherwise faulty switching and valve failure may result!  
 The pressure dew point must be at least 15 °C under ambient and medium temperature and may not exceed 3 °C .  
 The oil content of compressed air must remain constant during the life cycle.  
 Use only the approved oils from AVENTICS. Further information can be found in the "Technical information" document (available in the MediaCentre).



## Technical information

Material

Base plate

Aluminum

## Dimensions

### Dimensions

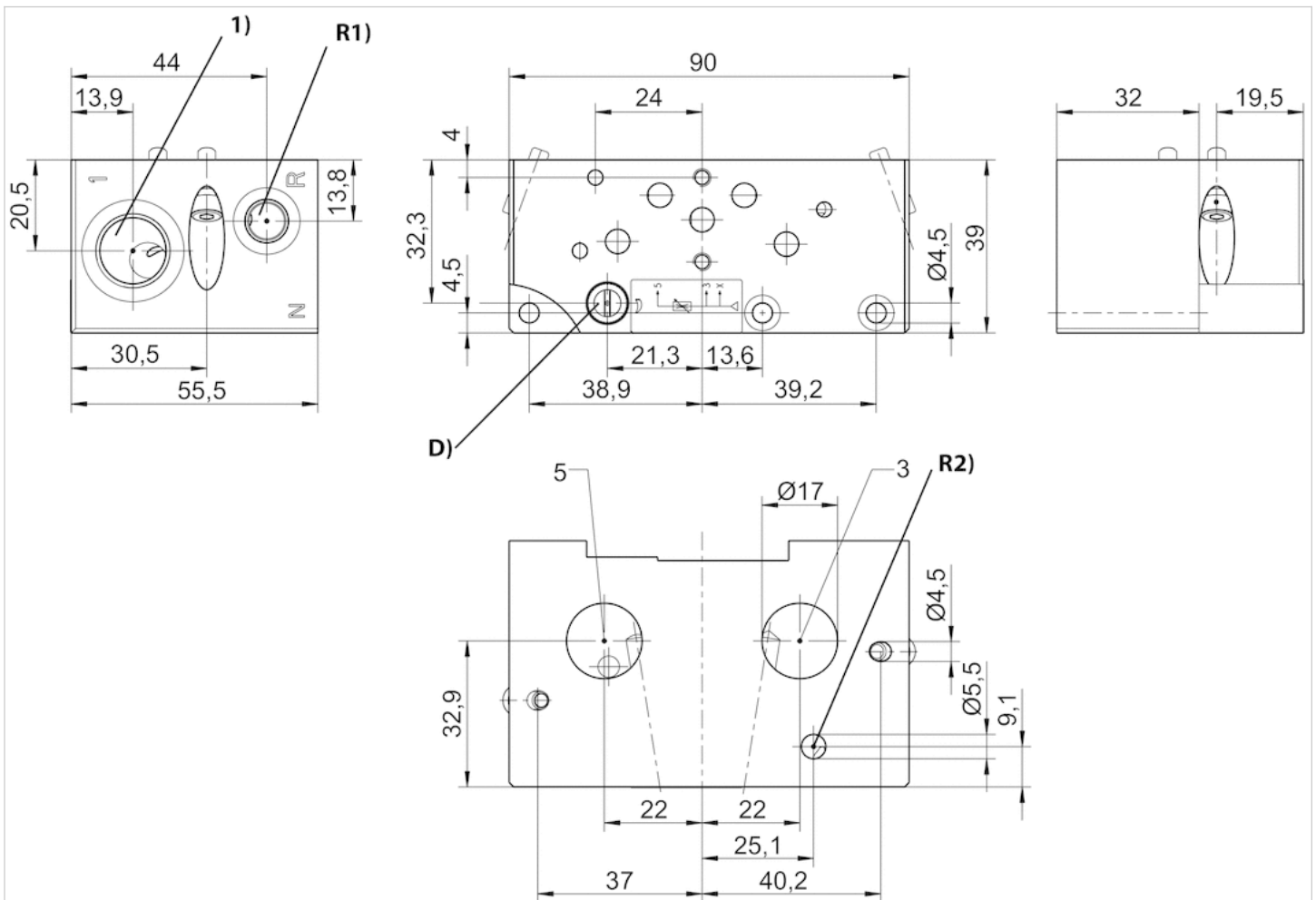

1) Operating pressure

D = Throttle (cleaning pressure)

R1) Test module exhaust/sealing air connection (max. 1 bar )

R2) Pilot control exhaust

# Separator

- for MS01-PA, CD01-PA
- standard ISO 15407-1, 26 mm
- type B



Standards  
Weight

ISO 15407-1  
0.003 kg

## Technical data

Part No.	Type	Accessory type	Frame size
R412015167	Separator for connections 1, 3, 5	type B	26 mm

## Technical information

Material	
Housing	Aluminum
Seal	Acrylonitrile butadiene rubber

## Dimensions

### Dimensions

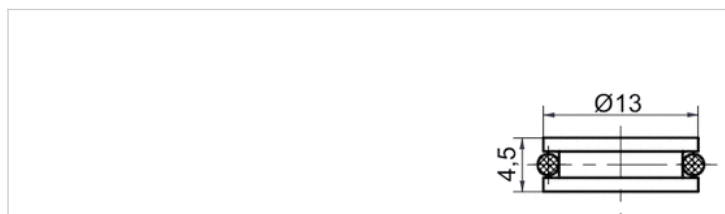

# Efficient pneumatic solutions, our program: cylinders and drives, valves and valve systems, air supply management



Visit us: [Emerson.com/Aventics](https://www.emerson.com/Aventics)

Your local contact: [Emerson.com/contactus](https://www.emerson.com/contactus)



Emerson.com



[Facebook.com/EmersonAutomationSolutions](https://www.facebook.com/EmersonAutomationSolutions)



[LinkedIn.com/company/Emerson-Automation-Solutions](https://www.linkedin.com/company/Emerson-Automation-Solutions)



[Twitter.com/EMR\\_Automation](https://twitter.com/EMR_Automation)

An example configuration is depicted on the title page. The delivered product may thus vary from that in the illustration. Subject to change. This Document, as well as the data, specifications and other information set forth in it, are the exclusive property of AVENTICS GmbH. It may not be reproduced or given to third parties without its consent. Only use the AVENTICS products shown in industrial applications. Read the product documentation completely and carefully before using the product. Observe the applicable regulations and laws of the respective country. When integrating the product into applications, note the system manufacturer's specifications for safe use of the product. The data specified only serve to describe the product. No statements concerning a certain condition or suitability for a certain application can be derived from our information. The information given does not release the user from the obligation of own judgment and verification. It must be remembered that the products are subject to a natural process of wear and aging.

The Emerson logo is a trademark and service mark of Emerson Electric Co. Brand logotype are registered trademarks of one of the Emerson family of companies. All other marks are the property of their respective owners. © 2017 Emerson Electric Co. All rights reserved.  
2019-03



**CONSIDER IT SOLVED™**