

Series MSC



AVENTICS™ Series MSC



Mini slide, Series MSC-HG-EE

- Scope of delivery: incl. centering rings
- Ø 16-25 mm
- double-acting
- with magnetic piston
- Cushioning elastic
- Easy2Combine capable
- with double piston
- With integrated "High Performance" ball rail system



Working pressure min./max.	See table below
Ambient temperature min./max.	0 ... 60 °C
Medium	Compressed air
Max. particle size	5 µm
Oil content of compressed air	0 ... 1 mg/m³
Pressure for determining piston forces	6.3 bar
Weight	See table below

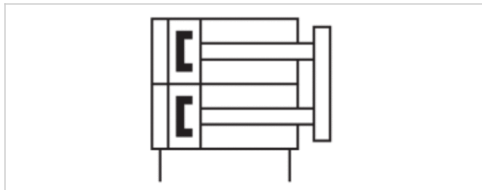

Technical data

Piston Ø	16 mm	20 mm	25 mm
Stroke 125	R412019175	R412018917	R412019030
150	R412019176	R412018918	R412019031
200	-	R412018919	R412019032

Technical data

Piston Ø 2x	16 mm	20 mm	25 mm
Working pressure min./max.	1 ... 10 bar	1 ... 10 bar	1 ... 10 bar
Retracting piston force, theoretical	218 N	297 N	520 N
Extracting piston force, theoretical	253 N	396 N	619 N
Speed max.	0.8 m/s	0.8 m/s	0.8 m/s
Cushioning length	1 mm	1.2 mm	1.6 mm
Cushioning energy	0.3 J	0.4 J	0.5 J

Technical information

The pressure dew point must be at least 15 °C under ambient and medium temperature and may not exceed 3 °C .

The oil content of compressed air must remain constant during the life cycle.

Use only the approved oils from AVENTICS. Further information can be found in the “Technical information” document (available in the MediaCentre).

Repetitive precision after 100 consecutive strokes: 0,3 mm

Base with air connections at the back and sides

Intermediate strokes can be configured.

Scope of delivery: incl. centering rings

R1 = stroke setting range for forward stroke

R2 = stroke setting range for return stroke

Ø 8 has a different reference plane.

Technical information

Material	
Housing	Aluminum, anodized
Piston rod	Stainless steel
Front plate	Aluminum, anodized
Seal	Polyurethane
Ball rail table	Aluminum, anodized
Guide rail	Steel, hardened
Centering rings	Stainless steel

Dimensions

Dimensions

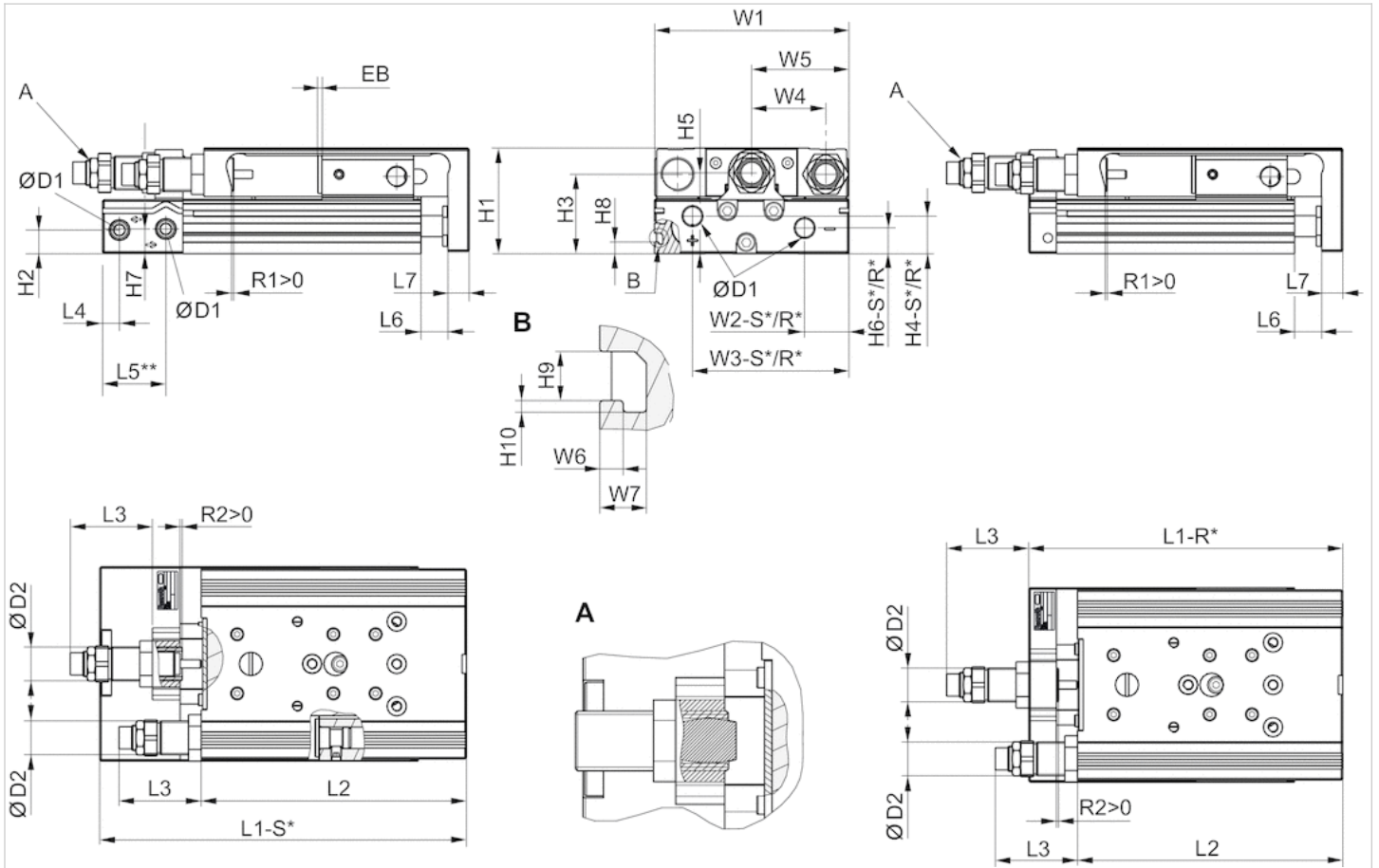

R*: base with air connections only at the back
 S*: base with air connections at the back and sides

Stroke-dependent dimensions

Piston Ø	S=125 EB	S=150 EB	S=200 EB	S=125 L1-R	S=150 L1-R	S=200 L1-R
16 mm	2	2	–	283	308	–
20 mm	2	2	2	289.5	329.5	404.5
25 mm	2	2	2	294.5	334.5	409.5

Piston Ø	S=125 L1-S	S=150 L1-S	S=200 L1-S	S=125 L2	S=150 L2	S=200 L2
16 mm	293.9	318.9	–	269.9	294.9	–
20 mm	314.4	354.4	429.4	275	315	390
25 mm	318.2	358.2	433.2	277.5	317.5	392.5

Dimensions

Piston Ø	Ø D1	Ø D2	H1	H2	H3	H4-R	H4-S	H5	H6-R	H6-S	H7	H8	H9	H10	L3 max.	L4
16 mm	M5	M12x1	40	7.2	29	12.2	12.2	31	7.7	7.7	11.2	–	–	–	18.4	6.5
20 mm	G 1/8	M16x1,5	50	11.2	37.5	17.3	17.3	38.2	11.7	12.2	11.7	5.5	4.2	1	27.9	8
25 mm	G 1/8	M18x1,5	60	14.2	44	15.5	22.9	46.5	13.2	21.7	16.2	6.9	5.2	1.5	29.2	9

Piston Ø	L5 2)	L6	L7	R2 max.	W1	W2-R	W2-S	W3-R	W3-S	W4	W5	W6	W7
16 mm	17.7	2	10	12.4	76	31	31	60.5	60.5	30	W1/2	–	–
20 mm	30	2.1	10	19.9	92	10	21	74	74	35	W1/2	2	4
25 mm	31	2.1	12	22.2	112	11	14	92	92	44	W1/2	2.5	4.8

Dimensions

MSC-16

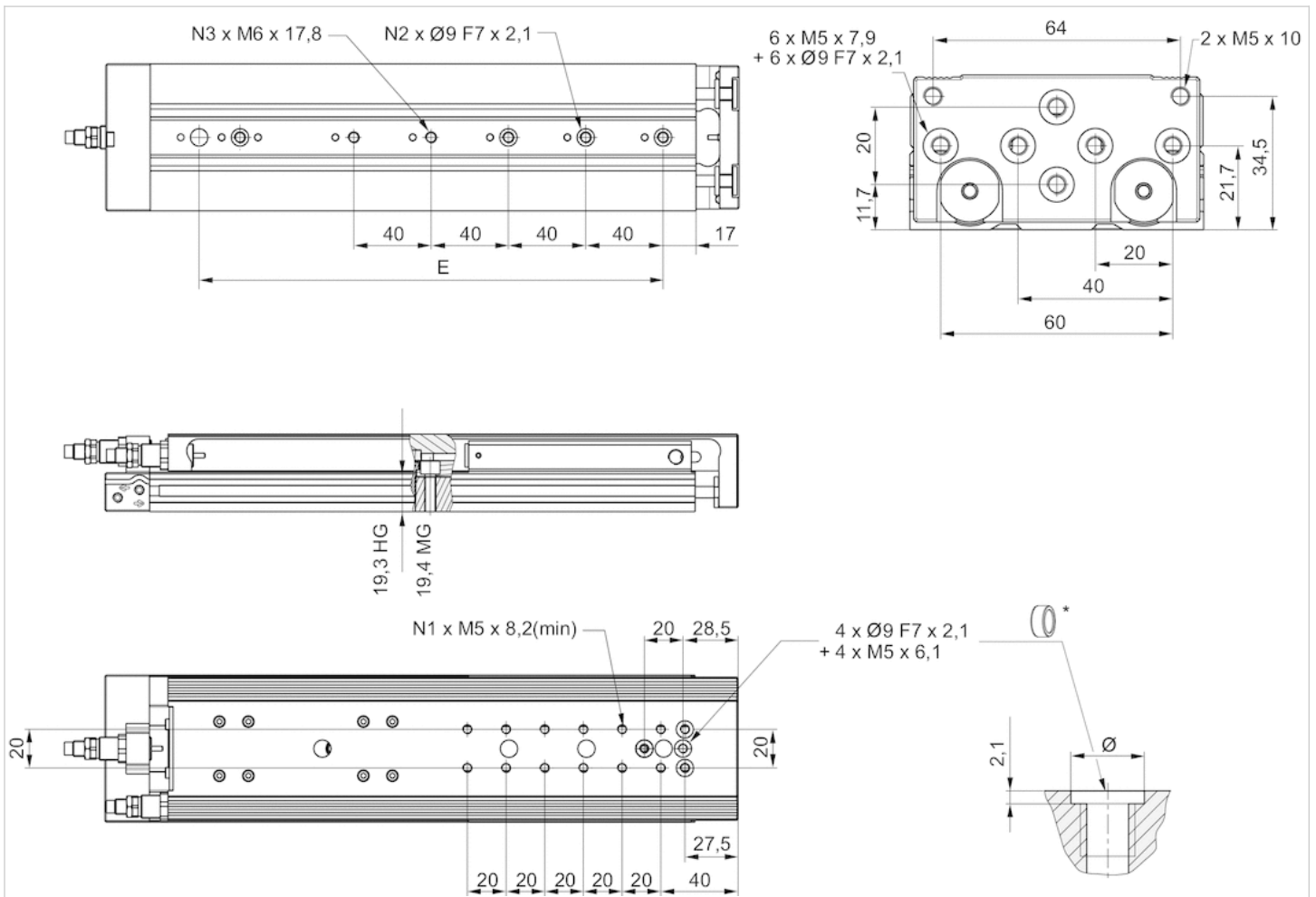

* = centering rings

Dimensions

Piston Ø	Stroke	E	N1	N2	N3
16 mm	125	200	12	4	5
16 mm	150	240	12	4	5

Dimensions

MSC-20

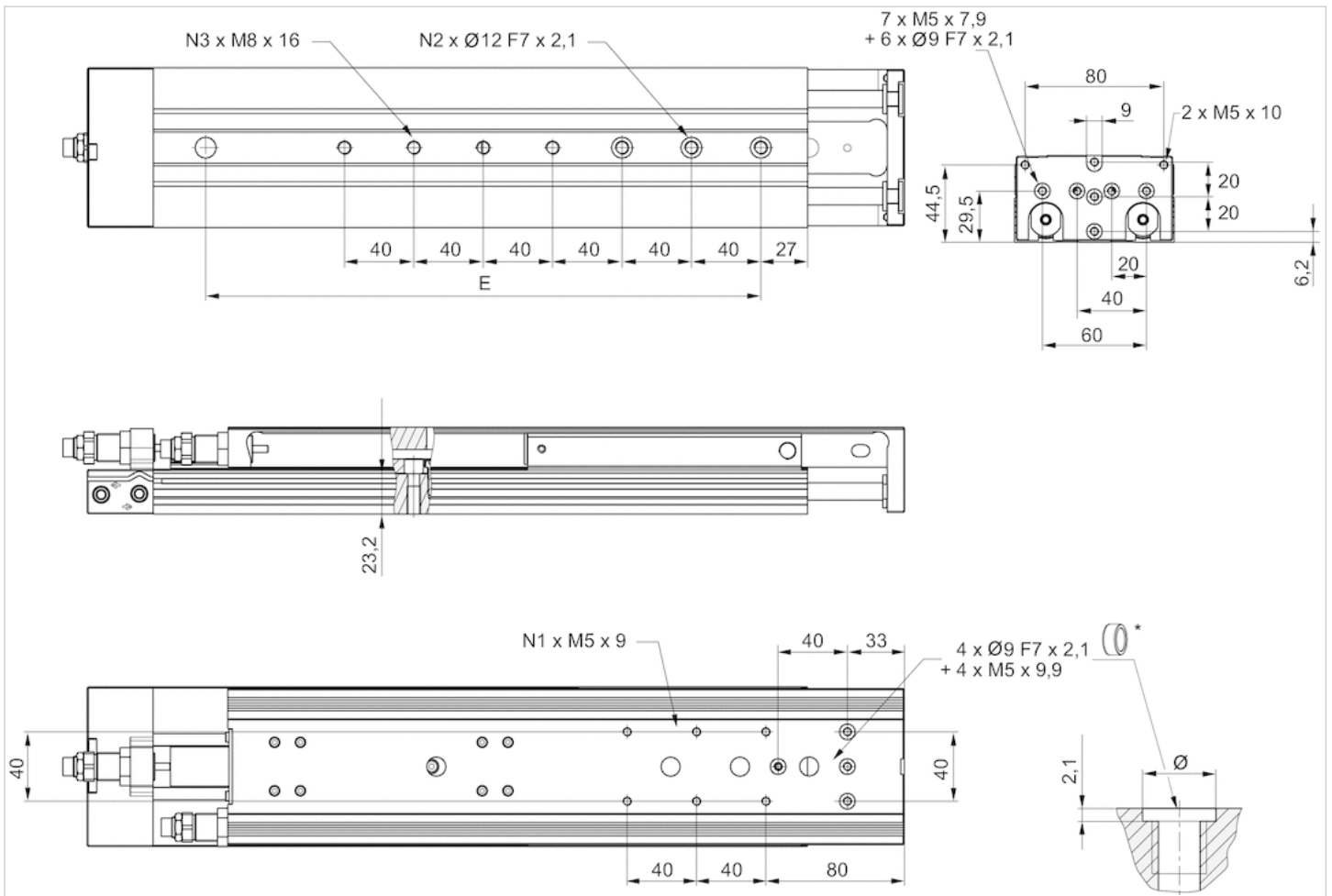

* = centering rings

Dimensions

Piston \varnothing	Stroke	E	N1	N2	N3
20 mm	125	200	6	4	5
20 mm	150	240	6	4	5
20 mm	200	320	6	4	7

Dimensions

MSC-25

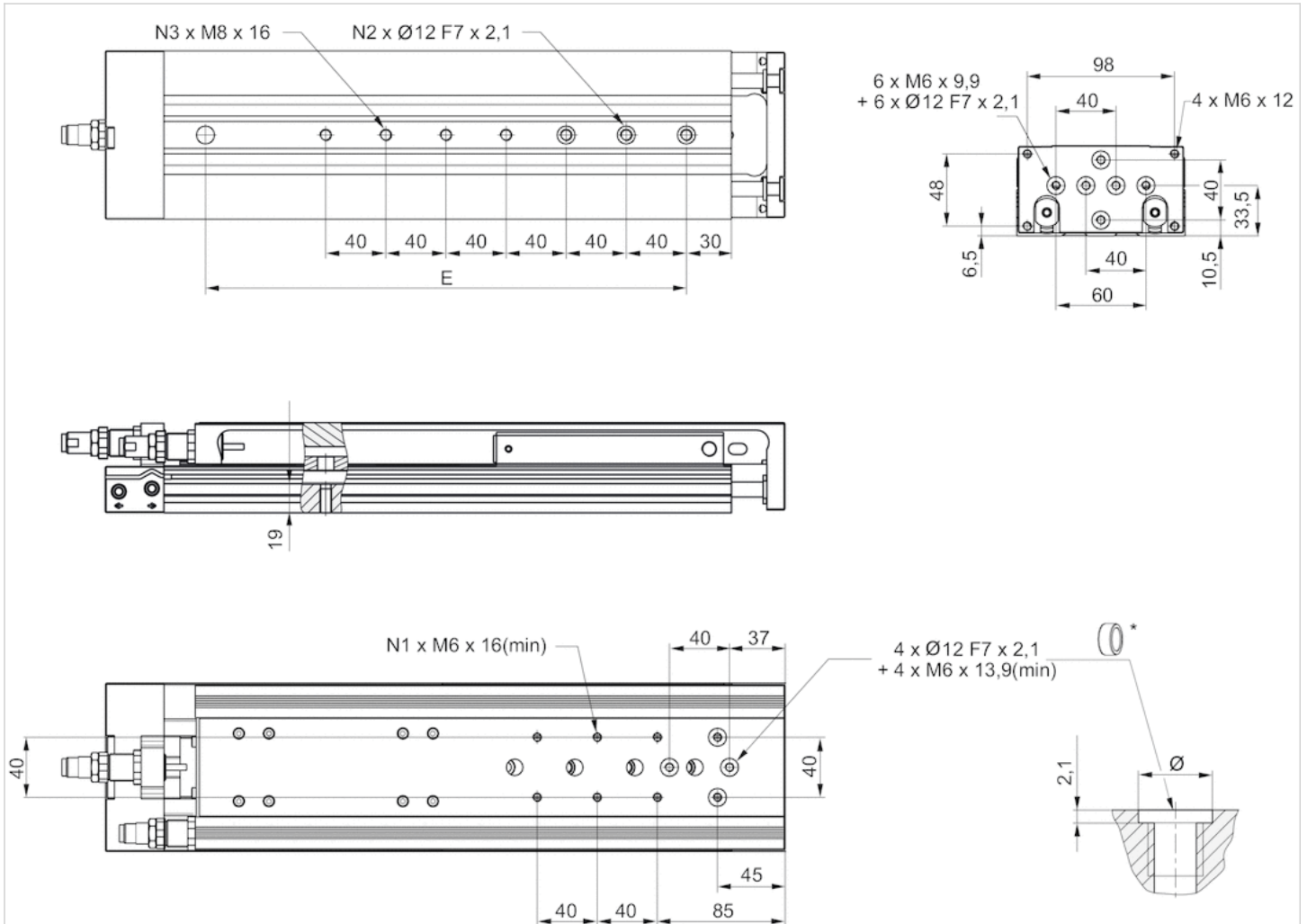

* = centering rings

Dimensions

Piston \varnothing	Stroke	E	N1	N2	N3
25 mm	125	200	4	4	5
25 mm	150	240	6	4	5
25 mm	200	320	6	4	7

Weight of moving parts [kg]

Piston Ø	S=125	S=150	S=200
16 mm	0.725	0.765	–
20 mm	1.2	1.29	1.54
25 mm	1.885	2.085	2.445

Weight [kg]

Piston Ø	Stroke	Weight kg
16 mm	125	1.94 kg
16 mm	150	2.08 kg
20 mm	125	3.02 kg
20 mm	150	3.36 kg
20 mm	200	4.12 kg
25 mm	125	4.75 kg
25 mm	150	5.37 kg
25 mm	200	6.46 kg

Load capacity

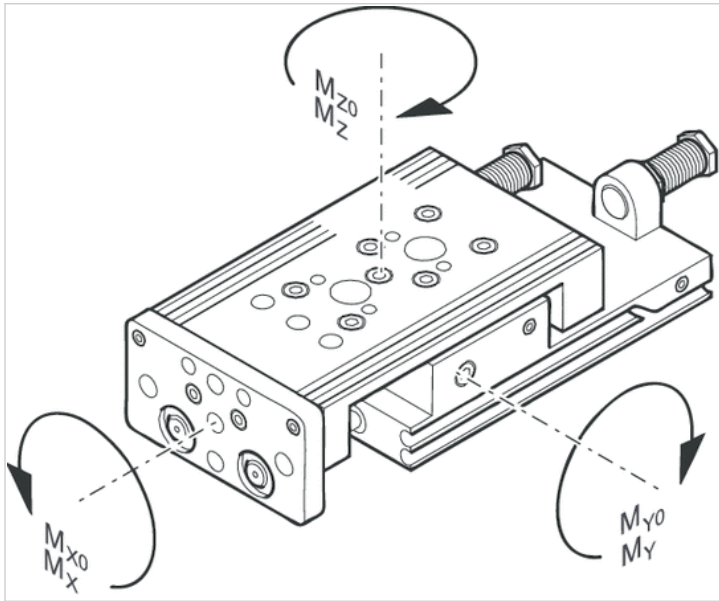

M = max. permissible torque

correction factor (a)

Piston Ø	Stroke	a [mm]	d [mm]	Mx0 Static moment M [Nm]
16 mm	125	198.5	15	88
16 mm	150	223.5	15	88
20 mm	125	201	20	126
20 mm	150	233.5	20	126
20 mm	200	296	20	126
25 mm	125	201	24	145
25 mm	150	236.5	24	145
25 mm	200	299	24	145

Piston Ø	My0 Static moment M [Nm]	Mz0 Static moment M [Nm]	Mx Dynamic moment M [Nm]
16 mm	118	118	15.2
16 mm	119	119	15.2
20 mm	136	136	19
20 mm	152	152	19
20 mm	179	179	19
25 mm	180	180	20.4
25 mm	201	201	20.4
25 mm	236	236	20.4

Piston Ø	My Dynamic moment M [Nm]	Mz Dynamic moment M [Nm]
16 mm	31.2	31.2
16 mm	31.2	31.2
20 mm	40.6	40.6
20 mm	45.4	45.4
20 mm	53.4	53.4
25 mm	44.1	44.1
25 mm	49.2	49.2
25 mm	57.8	57.8

correction factor (a, d)

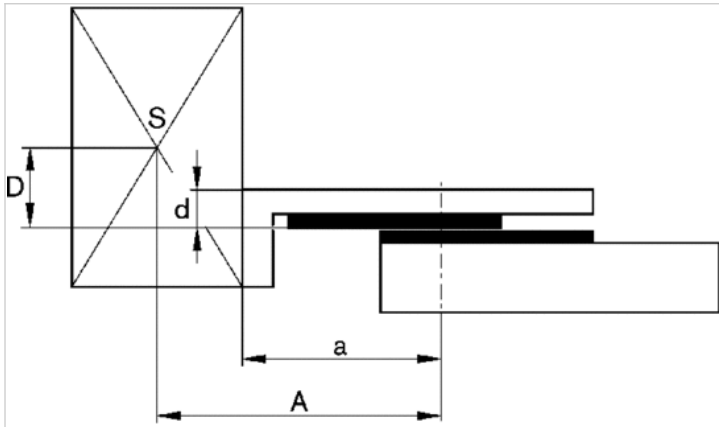

horizontal

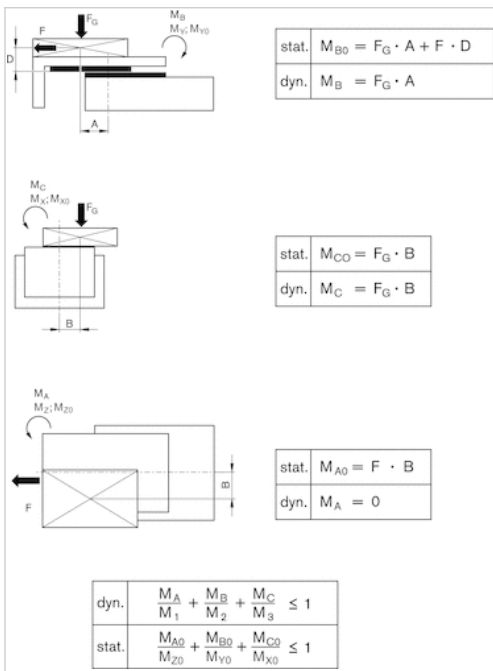

$F = m \cdot a$
 $FG = m \cdot g$
 $a = 1250 \cdot V^2 / H$

- F = deceleration force [N]
- FG= force due to weight [N]
- m = load mass [kg]
- a = deceleration [m/s²]
- g = gravitational acceleration 9,81 [m/s²]
- V = velocity [m/s]
- H = stroke length of shock absorber [mm]

vertical

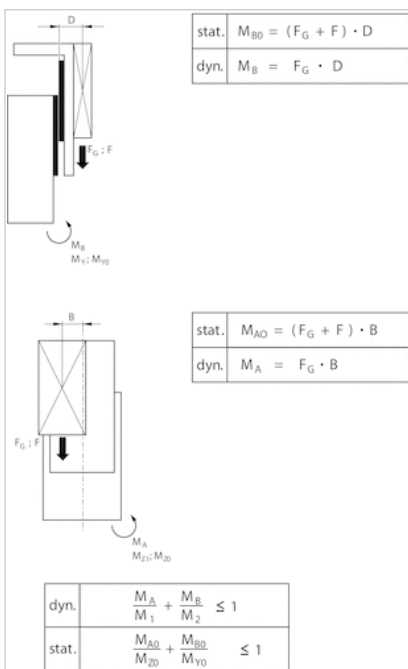

$F = m \cdot a$
 $FG = m \cdot g$

$$a = 1250 \cdot V^2 / H$$

F = deceleration force [N]

FG = force due to weight [N]

m = load mass [kg]

a = deceleration [m/s²]

g = gravitational acceleration 9,81 [m/s²]

V = velocity [m/s]

H = stroke length of shock absorber [mm]

Diagrams

Maximum moving mass

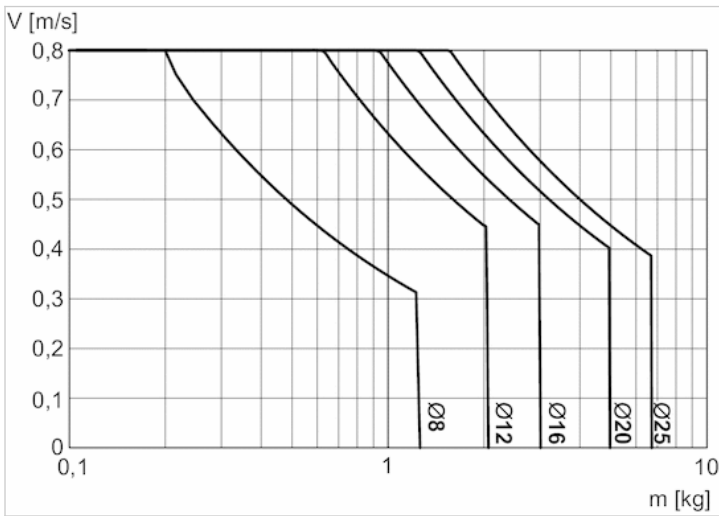

V = velocity [m/s]

m = mass

Correction factor for required speed: retracting and extending, horizontal

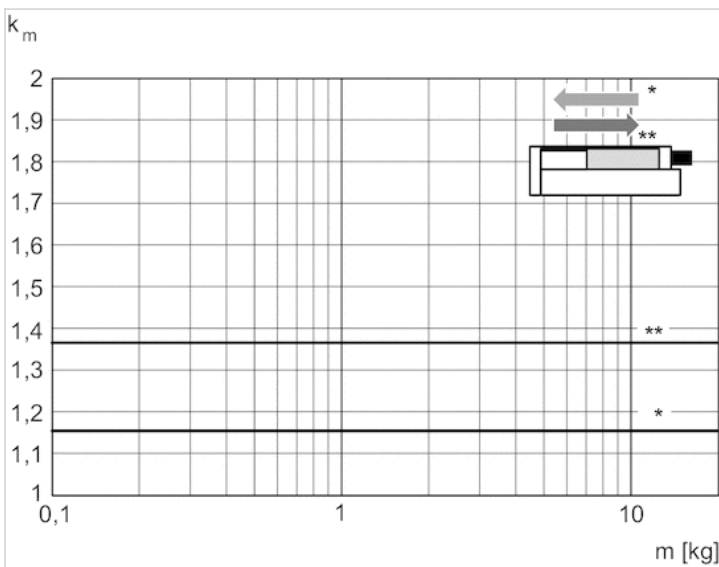

* retracting

** extracting

$$V = s / 1000 \cdot t \cdot k_m$$

V = velocity [m/s]

S = stroke

Correction factor for required speed: extending, vertical, upwards

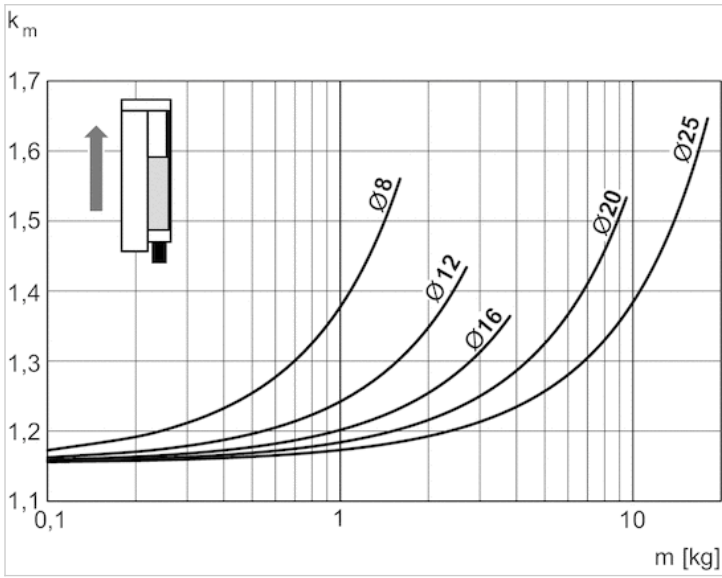

$V = s/1000 \cdot t \cdot k_m$
 $V = \text{velocity [m/s]}$
 $S = \text{stroke [mm]}$
 $t = \text{time [s] for one stroke}$
 $m = \text{mass}$

Correction factor for required speed: retracting, vertical, upwards

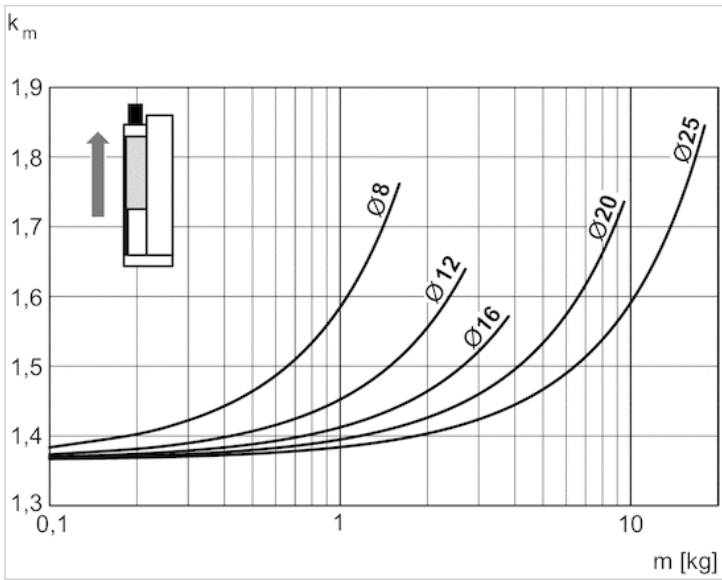

$V = s/1000 \cdot t \cdot k_m$
 $V = \text{velocity [m/s]}$
 $S = \text{stroke [mm]}$
 $t = \text{time [s] for one stroke}$
 $m = \text{mass}$

Correction factor for required speed: retracting, vertical, downwards

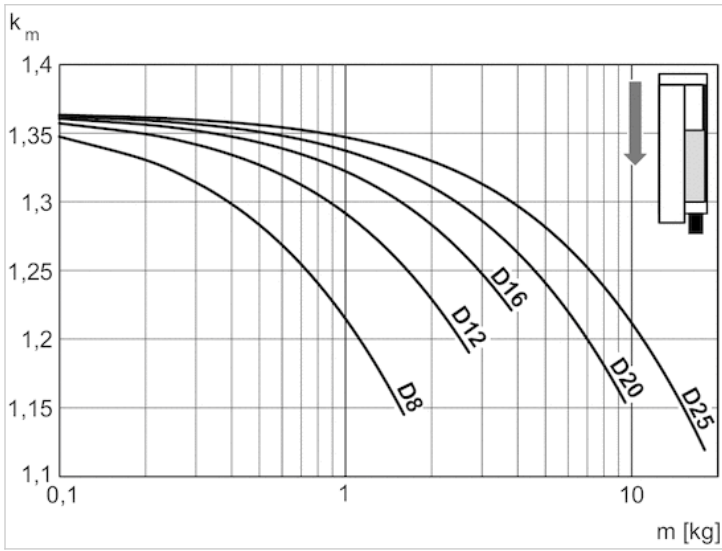

$V = s/1000 \cdot t \cdot k_m$
 V = velocity [m/s]
 S = stroke [mm]
 t = time [s] for one stroke
 m = mass

Correction factor for required speed: extending, vertical, downwards

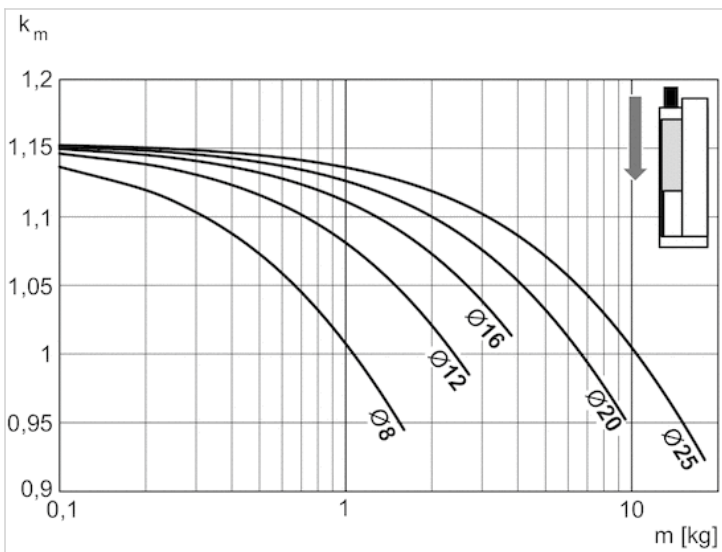

$V = s/1000 \cdot t \cdot k_m$
 V = velocity [m/s]
 S = stroke [mm]
 t = time [s] for one stroke
 m = mass

Extracting speed max.

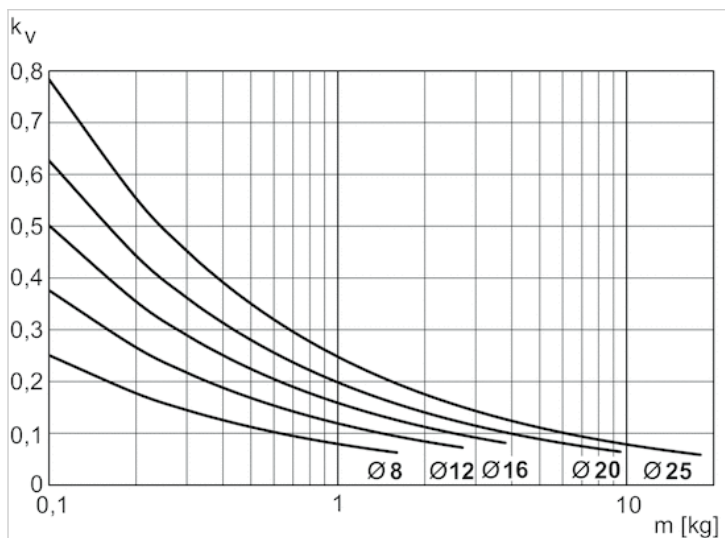

$V = \sqrt{s} \cdot kv$

V = velocity [m/s]

S = stroke [mm]

m = mass

Accessories overview

Overview drawing

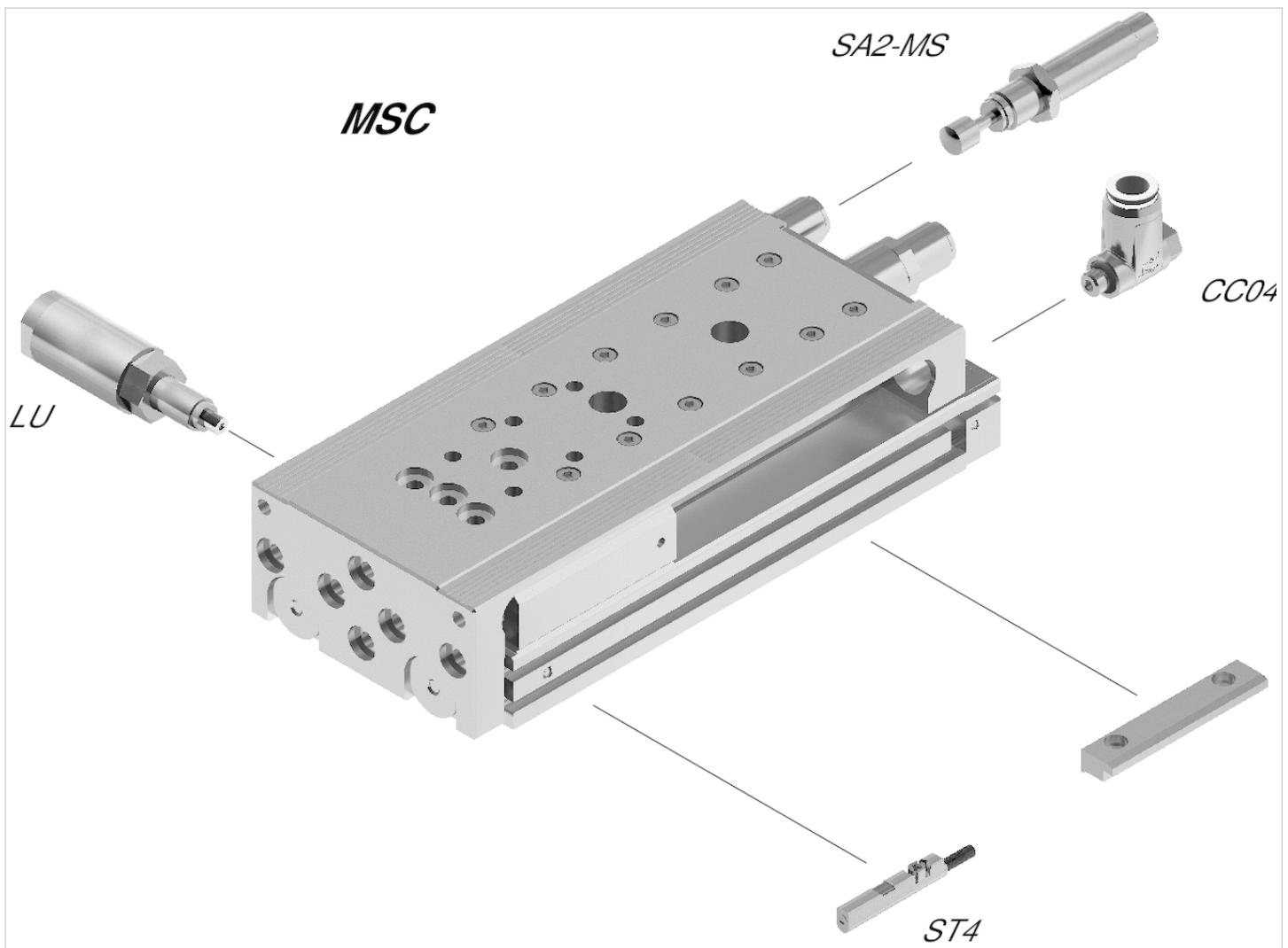

NOTE:

This overview drawing is only for orientation to indicate where the various accessory parts can be fastened to the cylinder. The illustration has been simplified for this purpose. It is thus not possible to derive the dimensions from this overview.

Mini slide, Series MSC-HG-EM

- Scope of delivery: incl. centering rings
- Ø 16-25 mm
- double-acting
- with magnetic piston
- Cushioning Elastic with metal end stop
- Easy2Combine capable
- with double piston
- With integrated "High Performance" ball rail system



Working pressure min./max.	3 ... 10 bar
Ambient temperature min./max.	0 ... 60 °C
Medium	Compressed air
Max. particle size	5 µm
Oil content of compressed air	0 ... 1 mg/m³
Pressure for determining piston forces	6.3 bar
Weight	See table below

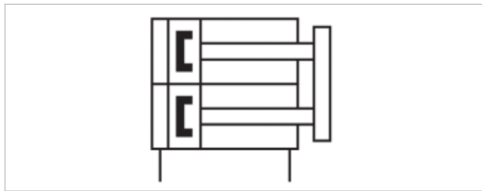

Technical data

Piston Ø	16 mm	20 mm	25 mm
Stroke 125	R480643808	R480643817	R480643827
150	R480643809	R480643818	R480643828
200	-	R480643819	R480643829

Base with air connections at the back and sides Intermediate strokes can be configured. Scope of delivery: incl. centering rings

Technical data

Piston Ø 2x	16 mm	20 mm	25 mm
Retracting piston force, theoretical	218 N	297 N	520 N
Extracting piston force, theoretical	253 N	396 N	619 N
Speed max.	0.8 m/s	0.8 m/s	0.8 m/s
Cushioning length	1.9 mm	3.05 mm	2.5 mm
Cushioning energy	0.12 J	0.3 J	0.4 J

Technical information

The pressure dew point must be at least 15 °C under ambient and medium temperature and may not exceed 3 °C .

The oil content of compressed air must remain constant during the life cycle.

Use only the approved oils from AVENTICS. Further information can be found in the "Technical information" document (available in the MediaCentre).

Repetitive precision after 100 consecutive strokes: 0,02 mm

Base with air connections at the back and sides

Intermediate strokes can be configured.

Scope of delivery: incl. centering rings

R1 = stroke setting range for forward stroke

R2 = stroke setting range for return stroke

Ø 8 has a different reference plane.

Technical information

Material	
Housing	Aluminum, anodized
Piston rod	Stainless steel
Front plate	Aluminum, anodized
Seal	Polyurethane
Ball rail table	Aluminum, anodized
Guide rail	Steel, hardened
Centering rings	Stainless steel

Dimensions

Dimensions

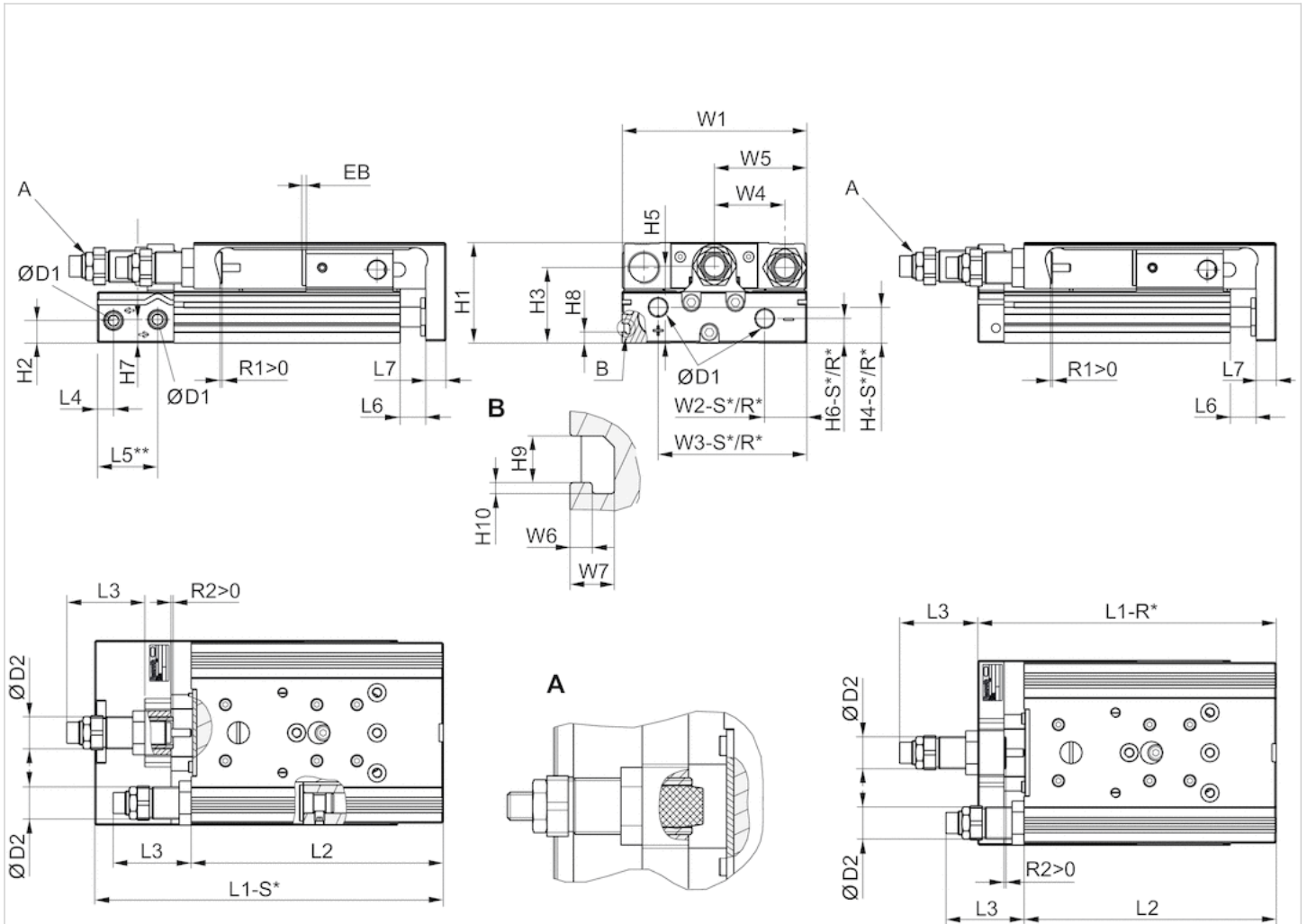

R*: base with air connections only at the back
 S*: base with air connections at the back and sides

Dimensions

Piston Ø	Ø D1	Ø D2	H1	H2	H3	H4-R	H4-S	H5	H6-R	H6-S	H7	H8	H9	H10	L3 max.	L4
16 mm	M5	M12x1	40	7.2	29	12.2	12.2	31	7.7	7.7	11.2	-	-	-	30	6.5
20 mm	G 1/8	M16x1,5	50	11.2	37.5	17.3	17.3	38.2	11.7	12.2	11.7	5.5	4.2	1	43.7	8
25 mm	G 1/8	M18x1,5	60	14.2	44	15.5	22.9	46.5	13.2	21.7	16.2	6.9	5.2	1.5	41.9	9

Piston Ø	L5 2)	L6	L7	R2 max.	W1	W2-R	W2-S	W3-R	W3-S	W4	W5	W6	W7
16 mm	17.7	2	10	10.4	76	31	31	60.5	60.5	30	W1/2	-	-
20 mm	30	2.1	10	14	92	10	21	74	74	35	W1/2	2	4
25 mm	31	2.1	12	16.2	112	11	14	92	92	44	W1/2	2.5	4.8

Stroke-dependent dimensions

Piston Ø	S=125 EB	S=150 EB	S=200 EB	S=125 L1-R	S=150 L1-R	S=200 L1-R
16 mm	2	2	–	283	308	–
20 mm	2	2	2	289.5	329.5	404.5
25 mm	2	2	2	294.5	334.5	409.5
Piston Ø	S=125 L1-S	S=150 L1-S	S=200 L1-S	S=125 L2	S=150 L2	S=200 L2
16 mm	293.9	318.9	–	269.9	294.9	–
20 mm	314.4	354.4	429.4	275	315	390
25 mm	318.2	358.2	433.2	277.5	317.5	392.5

Dimensions

MSC-16

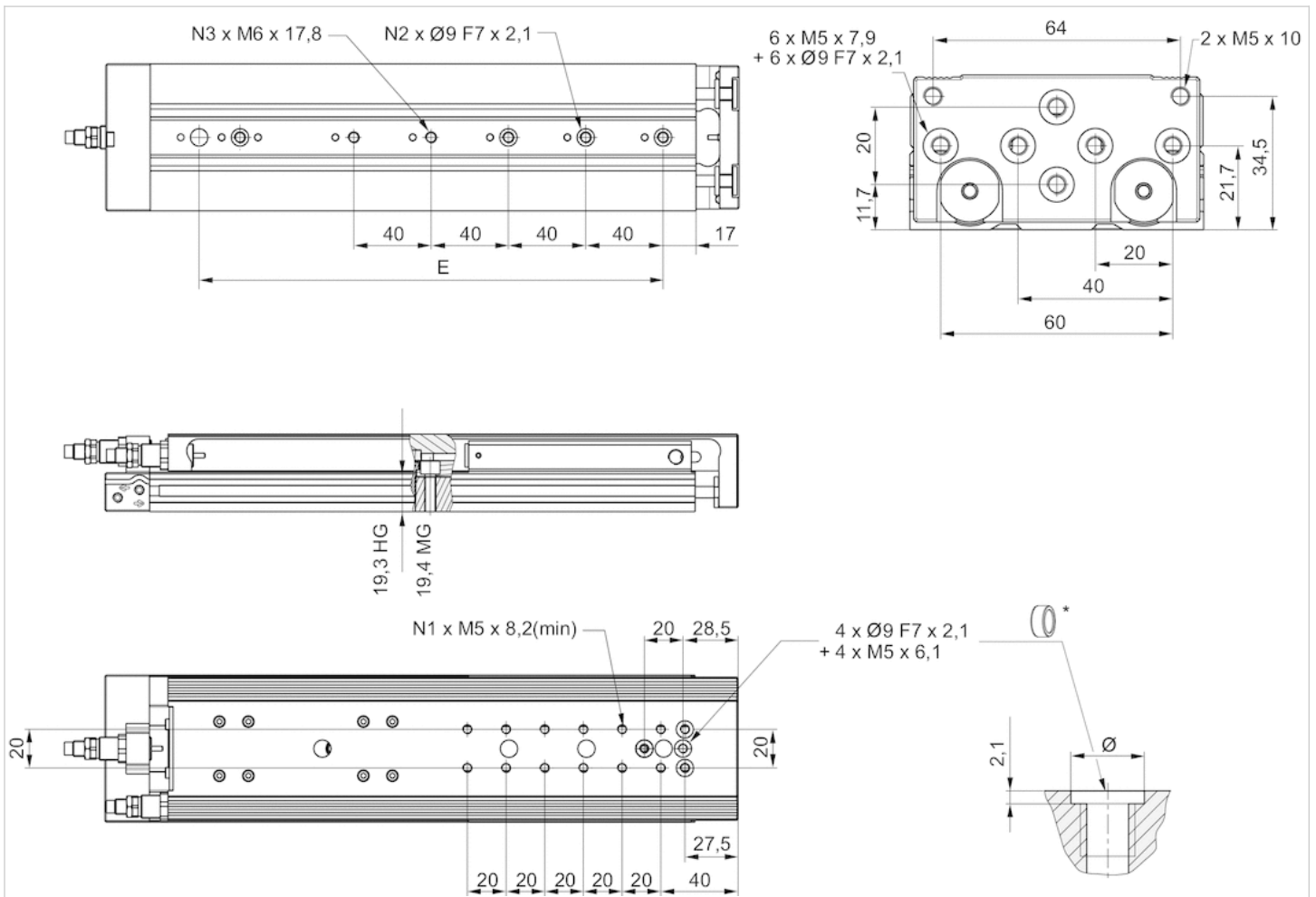

* = centering rings

Dimensions

Piston Ø	Stroke	E	N1	N2	N3
16 mm	125	200	12	4	5
16 mm	150	240	12	4	5

Dimensions

MSC-20

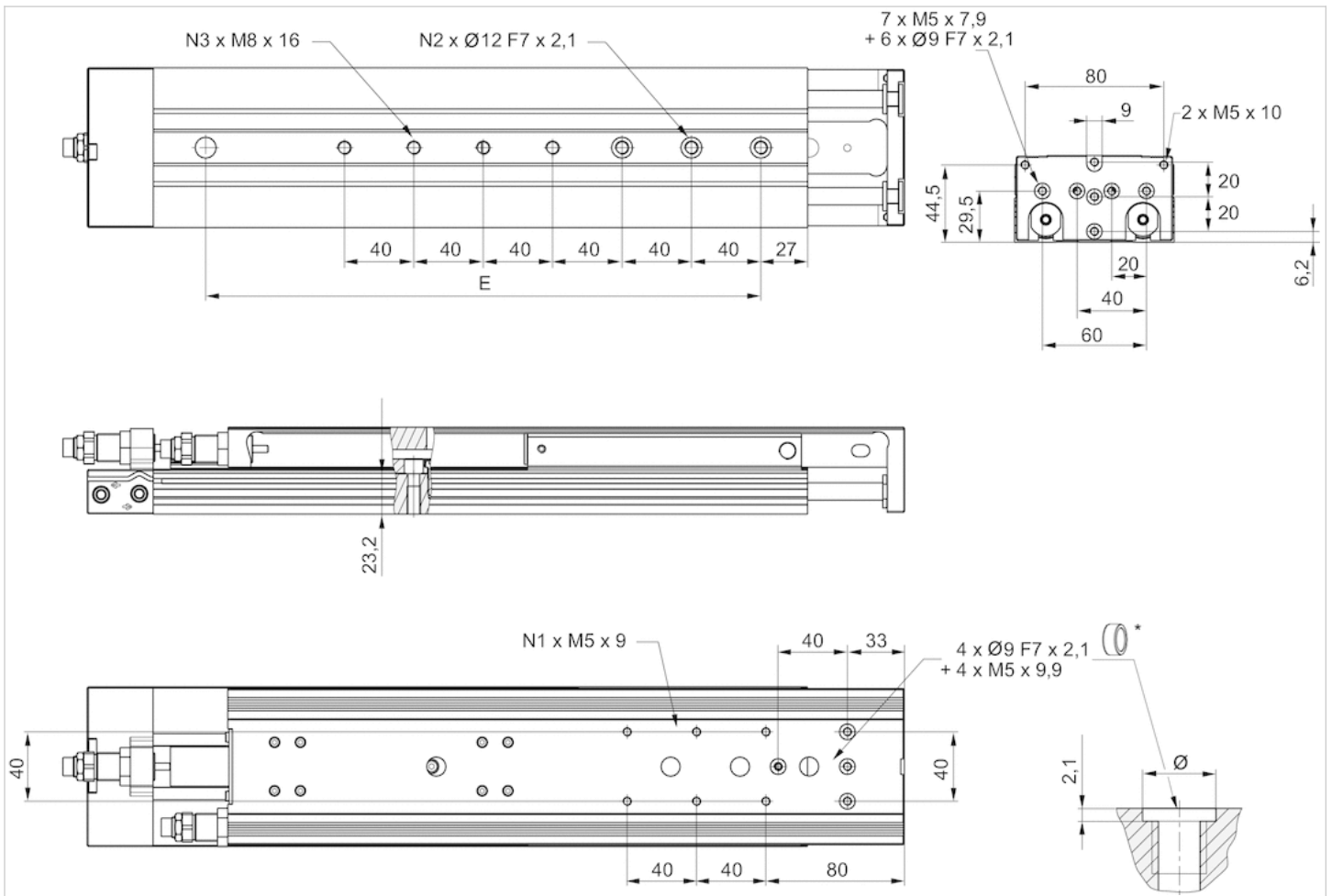

* = centering rings

Dimensions

Piston Ø	Stroke	E	N1	N2	N3
20 mm	125	200	6	4	5
20 mm	150	240	6	4	5
20 mm	200	320	6	4	7

Dimensions

MSC-25

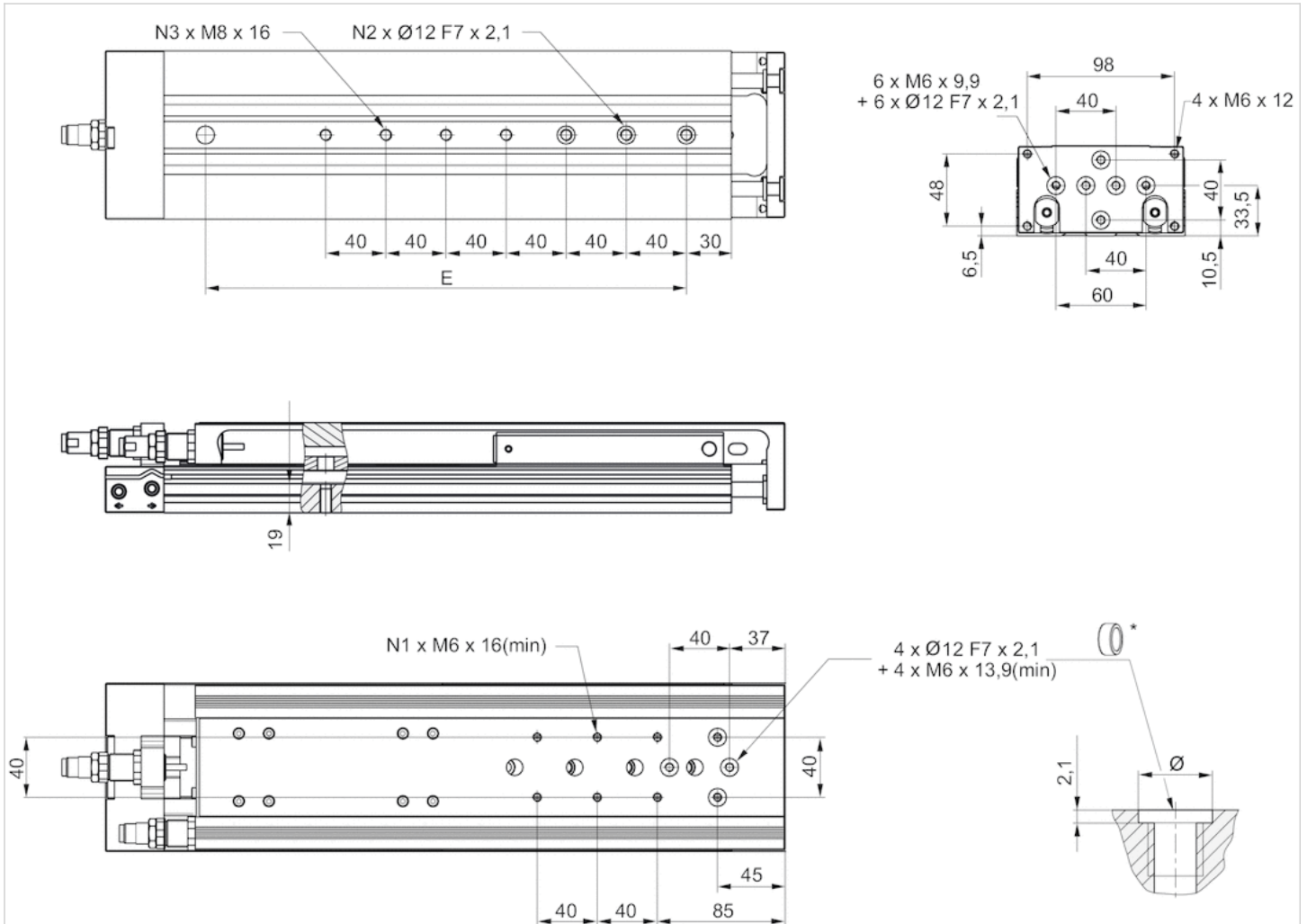

* = centering rings

Dimensions

Piston \varnothing	Stroke	E	N1	N2	N3
25 mm	125	200	4	4	5
25 mm	150	240	6	4	5
25 mm	200	320	6	4	7

Weight of moving parts [kg]

Piston Ø	S=125	S=150	S=200
16 mm	0.725	0.7655	–
20 mm	1.2	1.29	1.54
25 mm	1.885	2.085	2.445

S = stroke

Weight [kg]

Piston Ø	S	Weight kg
16 mm	125	1.94 kg
16 mm	150	2.08 kg
20 mm	125	3.02 kg
20 mm	150	3.36 kg
20 mm	200	4.12 kg
25 mm	125	4.75 kg
25 mm	150	5.37 kg
25 mm	200	6.46 kg

S = stroke

Load capacity

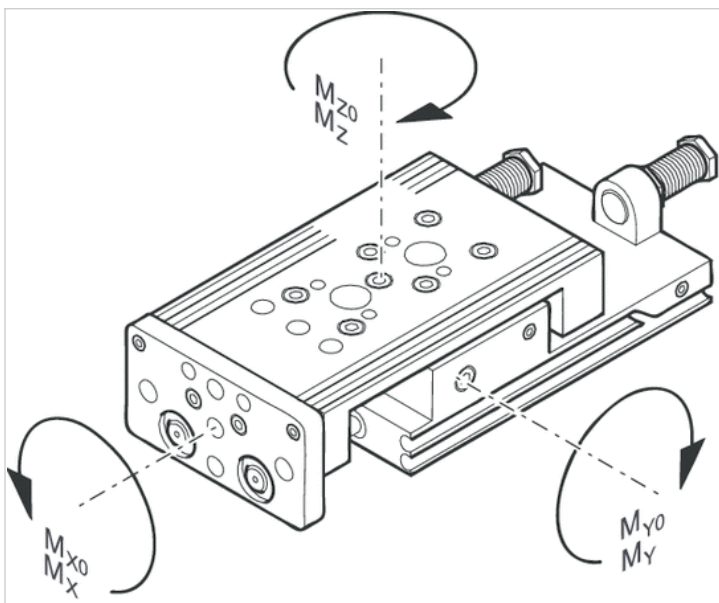

M = max. permissible torque

Piston Ø	S	a [mm] 1)	d [mm] 2)	Mx0 3)	My0 3)	Mz0 3)	Mx 4)	My 4)	Mz 4)
16 mm	125	198.5	15	88	118	118	15.2	31.2	31.2
16 mm	150	223.5	15	88	119	119	15.2	31.2	31.2
20 mm	125	201	20	126	136	136	19	40.6	40.6
20 mm	150	233.5	20	126	152	152	19	45.4	45.4
20 mm	200	296	20	126	179	179	19	53.4	53.4
25 mm	125	201	24	145	180	180	20.4	44.1	44.1
25 mm	150	236.5	24	145	201	201	20.4	49.2	49.2
25 mm	200	299	24	145	236	236	20.4	57.8	57.8

S = stroke

1) correction factor (

2) Correction factor (

3) Static moment M [N

4) Dynamic moment M [N

correction factor (a, d)

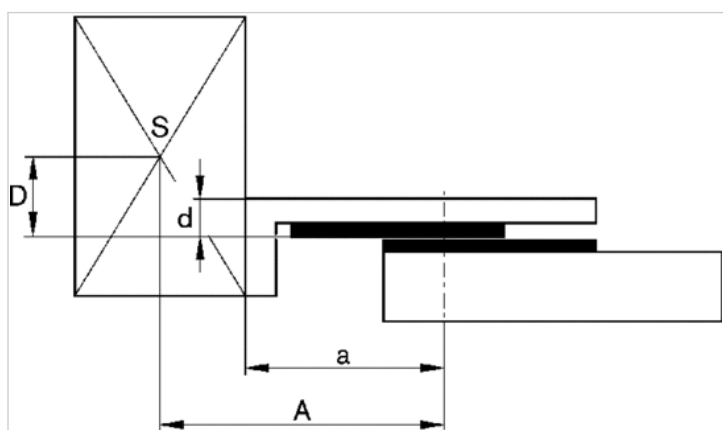

horizontal

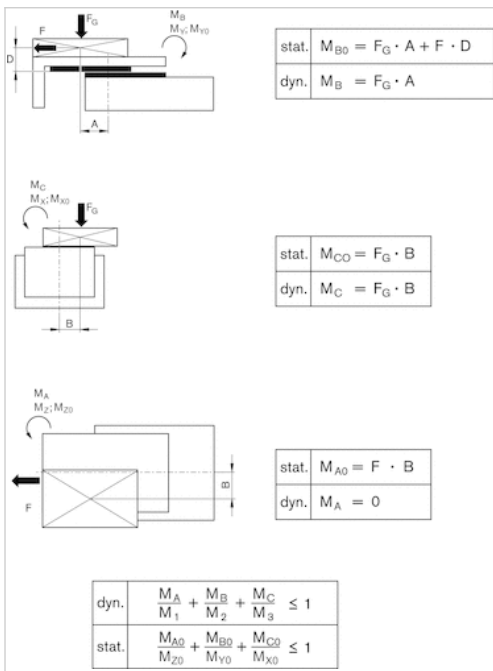

$F = m \cdot a$
 $FG = m \cdot g$
 $a = 1250 \cdot V^2 / H$

- F = deceleration force [N]
- FG= force due to weight [N]
- m = load mass [kg]
- a = deceleration [m/s²]
- g = gravitational acceleration 9,81 [m/s²]
- V = velocity [m/s]
- H = stroke length of shock absorber [mm]

vertical

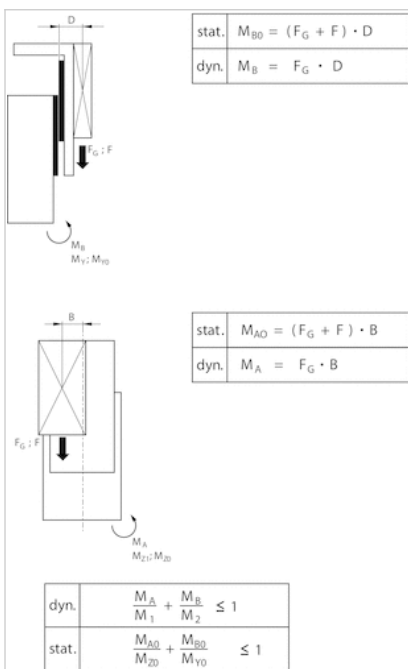

$F = m \cdot a$
 $FG = m \cdot g$

$$a = 1250 \cdot V^2 / H$$

F = deceleration force [N]

FG = force due to weight [N]

m = load mass [kg]

a = deceleration [m/s²]

g = gravitational acceleration 9,81 [m/s²]

V = velocity [m/s]

H = stroke length of shock absorber [mm]

Diagrams

Maximum moving mass

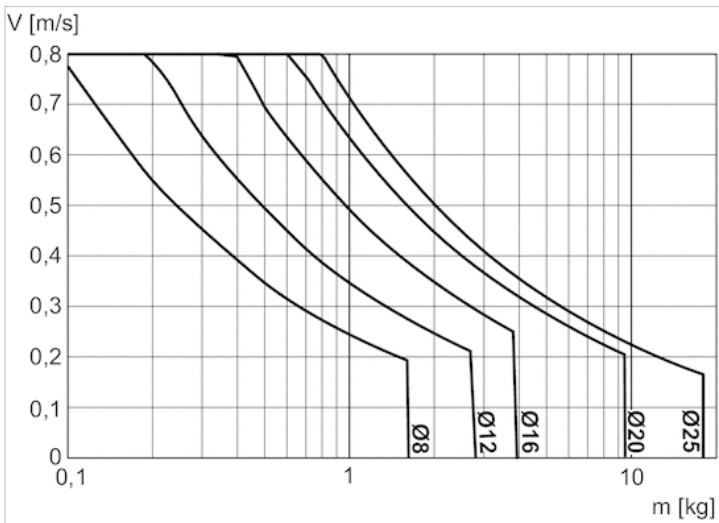

V = velocity [m/s]

m = mass

Correction factor for required speed: retracting and extending, horizontal

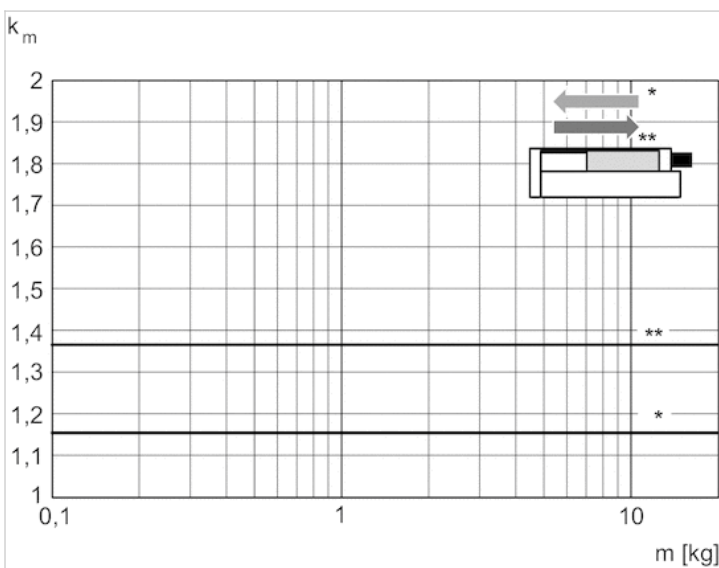

* retracting

** extracting

V = s/1000 • t • km

V = velocity [m/s]

S = stroke

Correction factor for required speed: extending, vertical, upwards

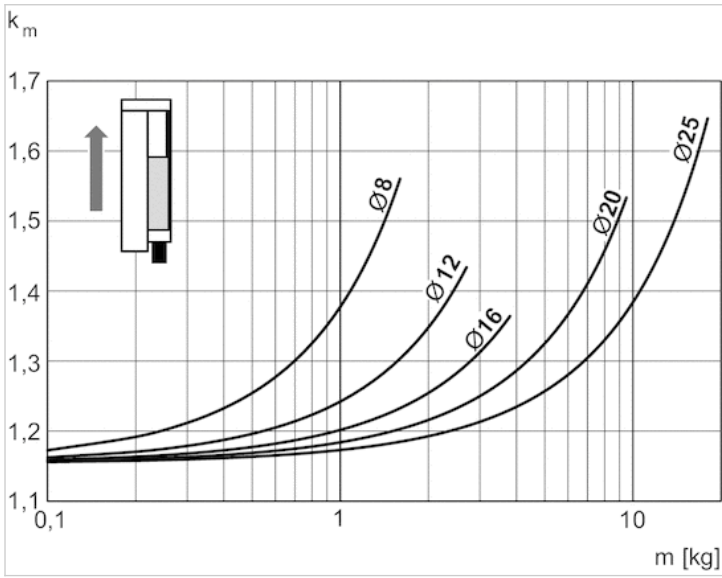

$V = s/1000 \cdot t \cdot k_m$
 $V = \text{velocity [m/s]}$
 $S = \text{stroke [mm]}$
 $t = \text{time [s] for one stroke}$
 $m = \text{mass}$

Correction factor for required speed: retracting, vertical, upwards

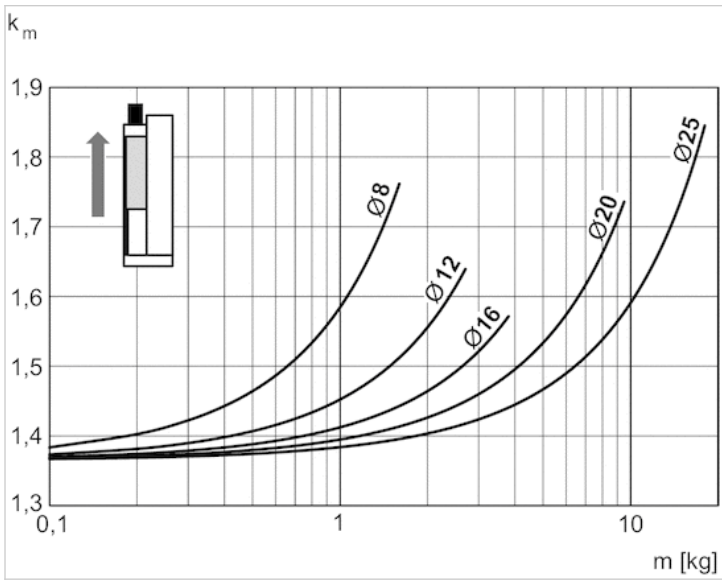

$V = s/1000 \cdot t \cdot k_m$
 $V = \text{velocity [m/s]}$
 $S = \text{stroke [mm]}$
 $t = \text{time [s] for one stroke}$
 $m = \text{mass}$

Correction factor for required speed: retracting, vertical, downwards

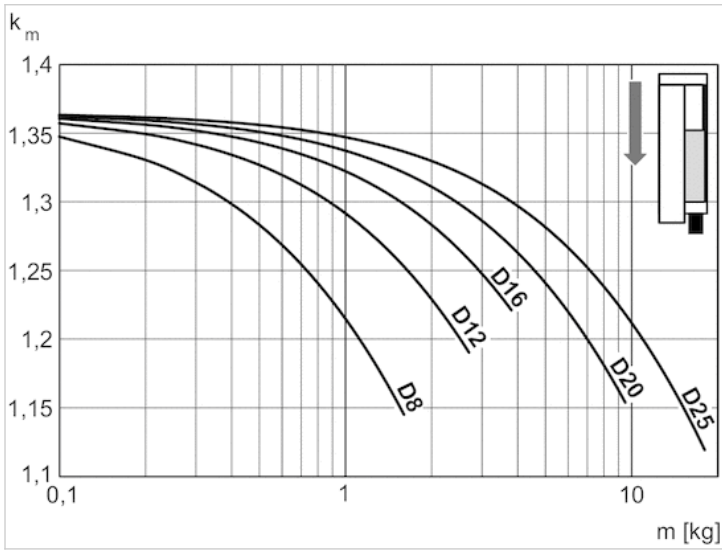

$V = s/1000 \cdot t \cdot k_m$
 $V =$ velocity [m/s]
 $S =$ stroke [mm]
 $t =$ time [s] for one stroke
 $m =$ mass

Correction factor for required speed: extending, vertical, downwards

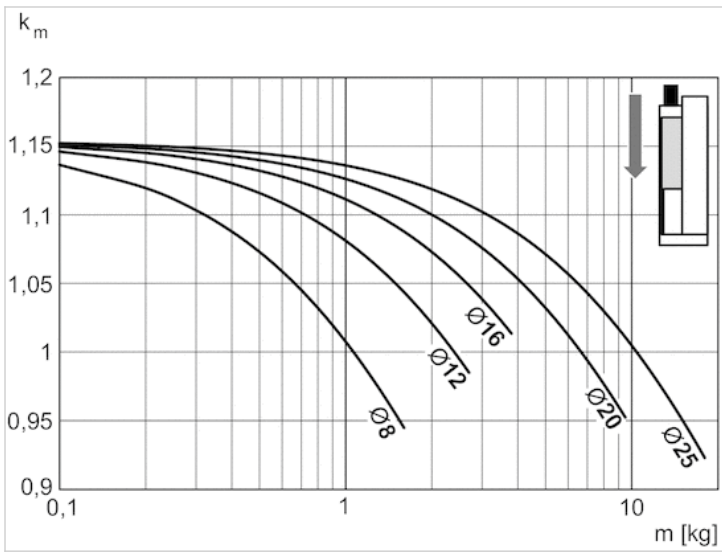

$V = s/1000 \cdot t \cdot k_m$
 $V =$ velocity [m/s]
 $S =$ stroke [mm]
 $t =$ time [s] for one stroke
 $m =$ mass

Extracting speed max.

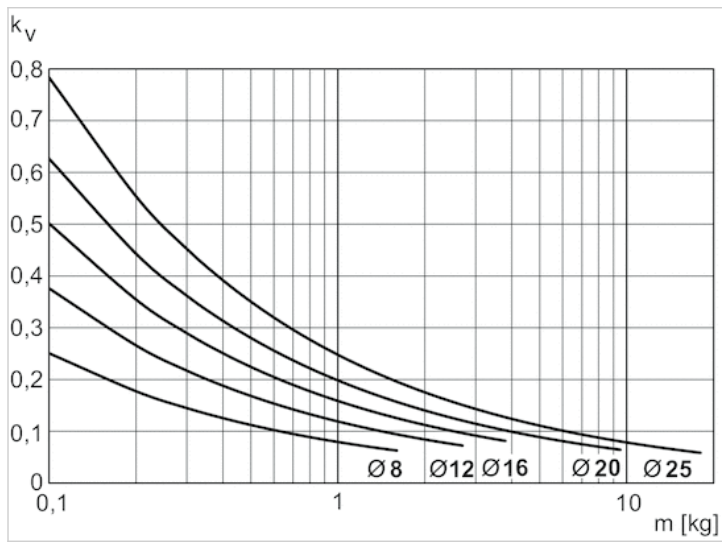

$$V = \sqrt{s} \cdot kv$$

V = velocity [m/s]

S = stroke [mm]

m = mass

Accessories overview

Overview drawing

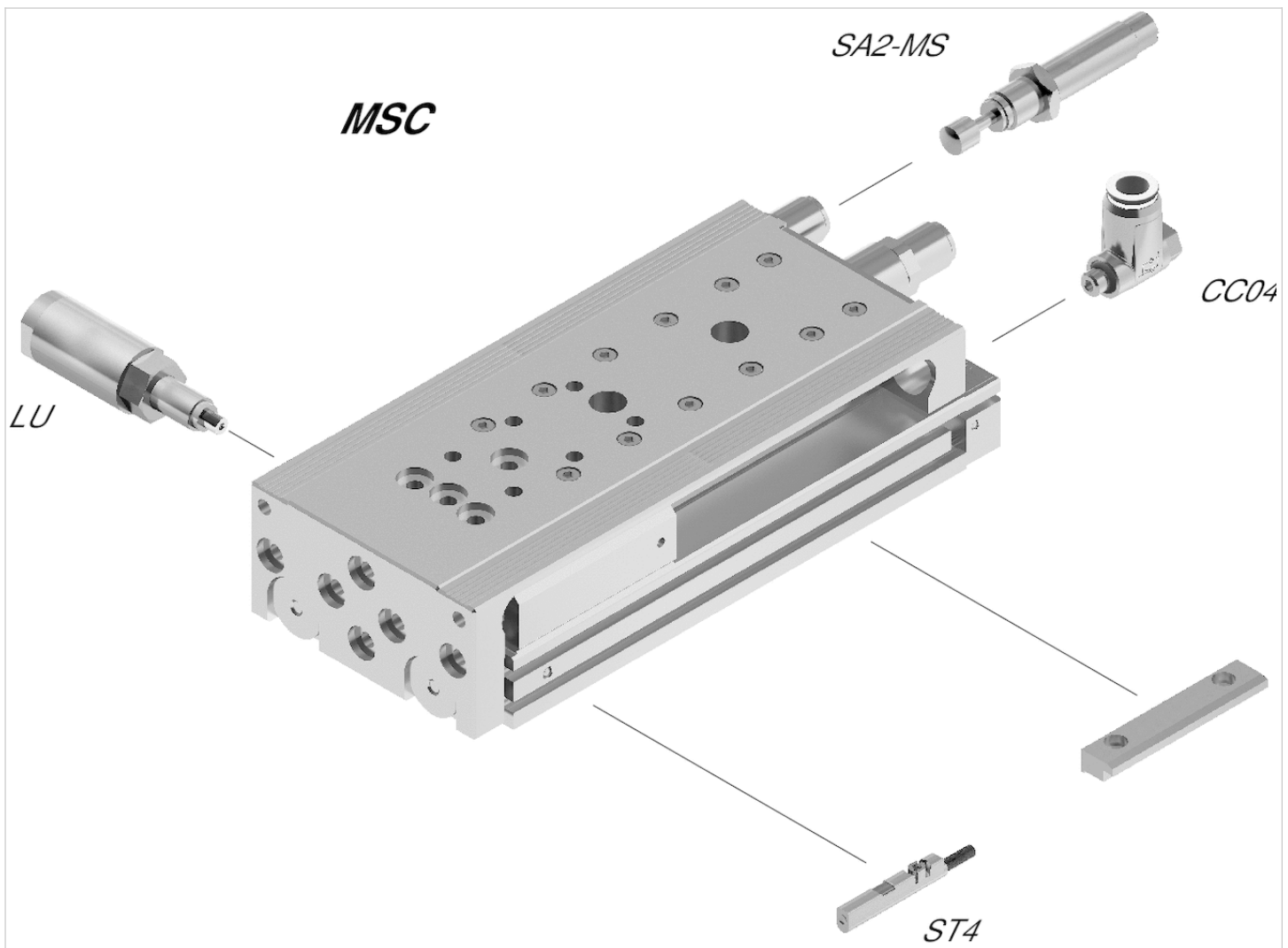

NOTE:

This overview drawing is only for orientation to indicate where the various accessory parts can be fastened to the cylinder. The illustration has been simplified for this purpose. It is thus not possible to derive the dimensions from this overview.

Mini slide, Series MSC-HG-PM/PE

- Scope of delivery: incl. centering rings
- Ø 16-25 mm
- double-acting
- with magnetic piston
- Cushioning pneumatically
- Easy2Combine capable
- with double piston
- With integrated "High Performance" ball rail system



Working pressure min./max.	See table below
Ambient temperature min./max.	0 ... 60 °C
Medium	Compressed air
Max. particle size	5 µm
Oil content of compressed air	0 ... 1 mg/m ³
Pressure for determining piston forces	6.3 bar
Repetitive precision	0,3 mm
Weight	See table below

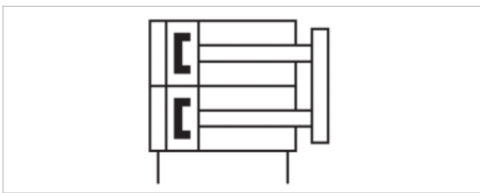

Technical data

Piston Ø	16 mm	20 mm	25 mm
125	R480640200	R480640205	R480640211
150	R480640201	R480640206	R480640212
200	-	R480640207	R480640213

Technical data

Piston Ø 2x	16 mm	20 mm	25 mm
Working pressure min./max.	3 ... 10 bar	3 ... 10 bar	2 ... 10 bar
Retracting piston force, theoretical	218 N	297 N	520 N
Extracting piston force, theoretical	182 N	269 N	421 N
Speed max.	0.8 m/s	0.8 m/s	0.8 m/s
Cushioning length	7 mm	7 mm	7 mm
Cushioning energy	0.06 J	1.2 J	1.6 J

Technical information

The pressure dew point must be at least 15 °C under ambient and medium temperature and may not exceed 3 °C .

The oil content of compressed air must remain constant during the life cycle.

Use only the approved oils from AVENTICS. Further information can be found in the "Technical information" document (available in the MediaCentre).

Repetitive precision after 100 consecutive strokes: 0,02 mm

Repeatability with variant with elastomer end stop: 0.3 mm

Cushioning length for variant with elastomer end stop: 10.5 mm

Base with air connections at the back and sides

Intermediate strokes can be configured.

Scope of delivery: incl. centering rings

R1 = stroke setting range for forward stroke

R2 = stroke setting range for return stroke

PE: cushioning: pneumatic, end stop: elastomer

PM: cushioning: pneumatic, end stop: metal

Technical information

Material	
Housing	Aluminum, anodized
Piston rod	Stainless steel
Front plate	Aluminum, anodized
Seal	Polyurethane
Ball rail table	Aluminum, anodized
Guide rail	Steel, hardened
Centering rings	Stainless steel

Dimensions

Dimensions

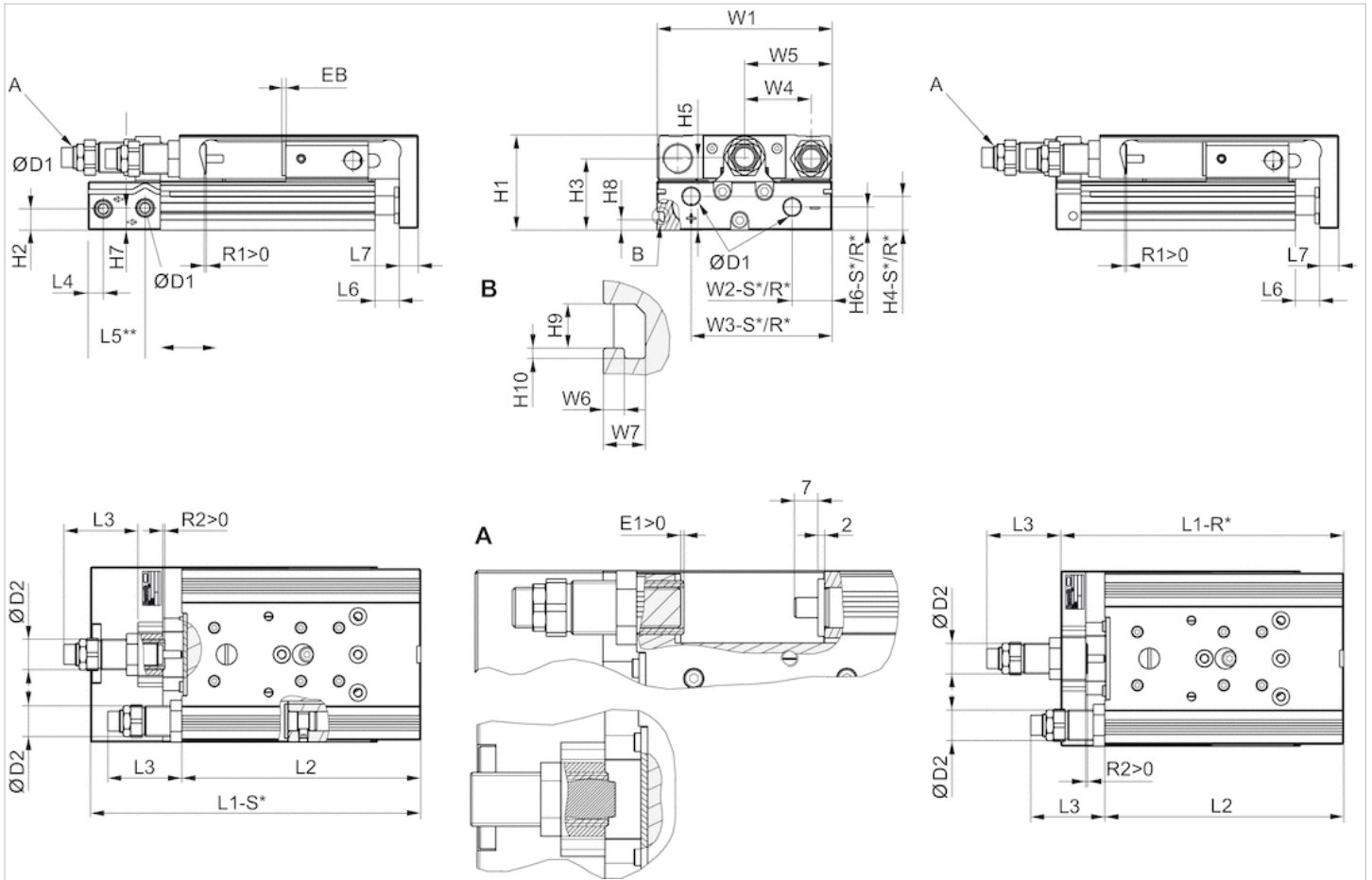

R*: base with air connections only at the back
 S*: base with air connections at the back and sides

Dimensions

Piston Ø	Ø D1	Ø D2	H1	H2	H3	H4-R	H4-S	H5	H6-R	H6-S	H7	H8	H9	H10	L3 1) max.
16 mm	M5	M12x1	40	7.2	29	12.2	12.2	31	7.7	7.7	11.2	-	-	-	12
20 mm	G 1/8	M16x1,5	50	11.2	37.5	17.3	17.3	38.2	11.7	12.2	11.7	5.5	4.2	1	15
25 mm	G 1/8	M18x1,5	60	14.2	44	15.5	22.9	46.5	13.2	21.7	16.2	6.9	5.2	1.5	15

Piston Ø	L3 2) max.	L4	L5 3)	L6	L7	R2	W1	W2-R	W2-S	W3-R	W3-S	W4	W5	W6	W7
16 mm	47	6.5	17.7	2	10	3	76	31	31	60.5	60.5	30	W1/2	-	-
20 mm	57	8	30	2.1	10	3	92	10	21	74	74	35	W1/2	2	4
25 mm	62	9	31	2.1	12	3	112	11	14	92	92	44	W1/2	2.5	4.8

Stroke-dependent dimensions

Piston Ø	S=125 EB	S=150 EB	S=200 EB	S=125 L1-R	S=150 L1-R	S=200 L1-R
16 mm	2	2	–	281.3	306.3	–
20 mm	2	2	2	287.4	327.4	402.4
25 mm	2	2	2	292.1	332.1	407.1

Piston Ø	S=125 L1-S	S=150 L1-S	S=200 L1-S	S=125 L2	S=150 L2	S=200 L2
16 mm	292.2	317.2	–	269.9	294.9	–
20 mm	312.3	352.3	427.3	275	315	390
25 mm	315.8	355.8	430.8	277.5	317.5	392.5

Piston Ø	S=125 R1	S=150 R1	S=200 R1	
16 mm	8.7	8.7	–	
20 mm	12.4	12.4	12.4	
25 mm	11.5	11.5	11.5	

Dimensions

MSC-16

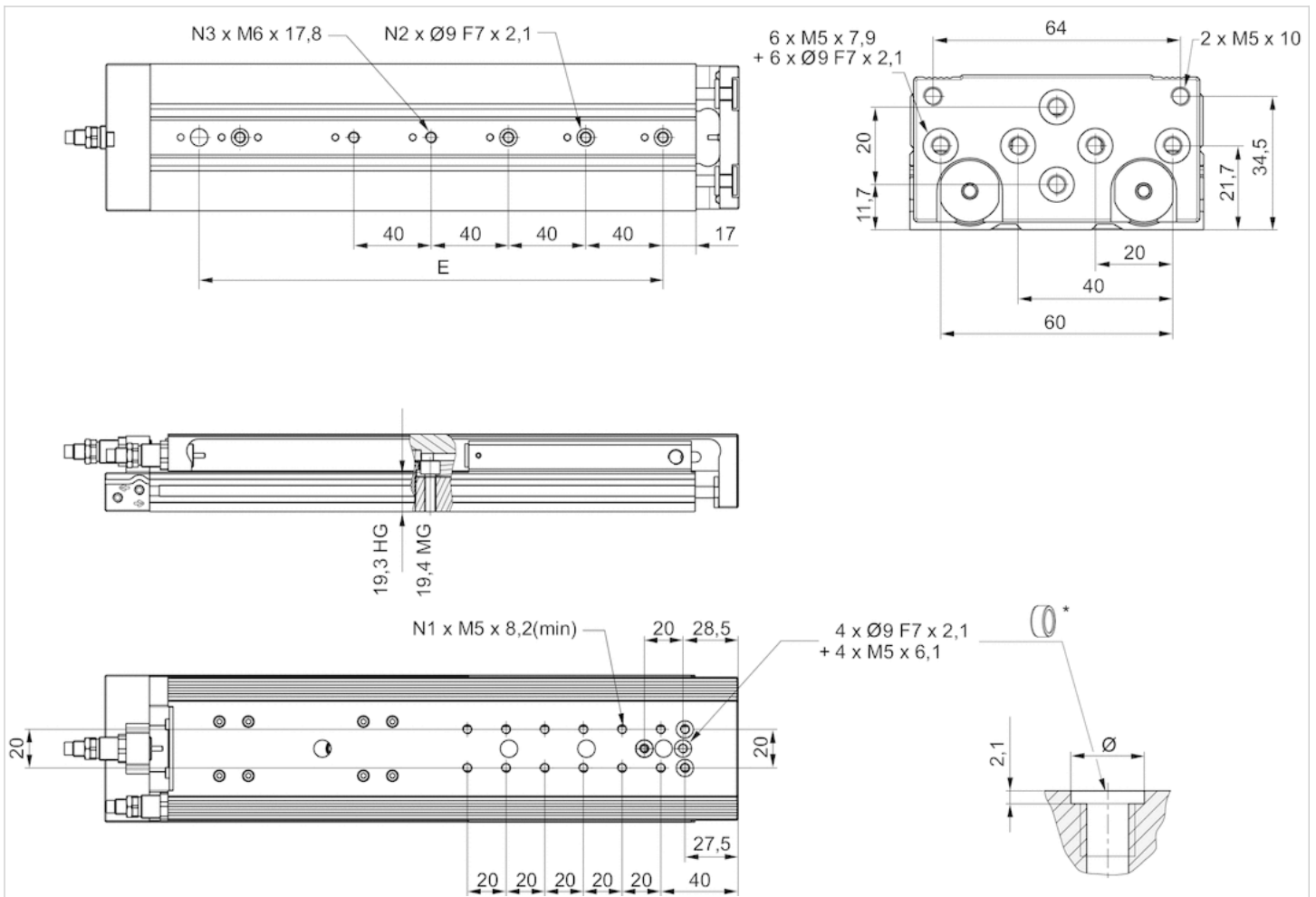

* = centering rings

Dimensions

Piston Ø	Stroke	E	N1	N2	N3
16 mm	125	200	12	4	5
16 mm	150	240	12	4	5

Dimensions

MSC-20

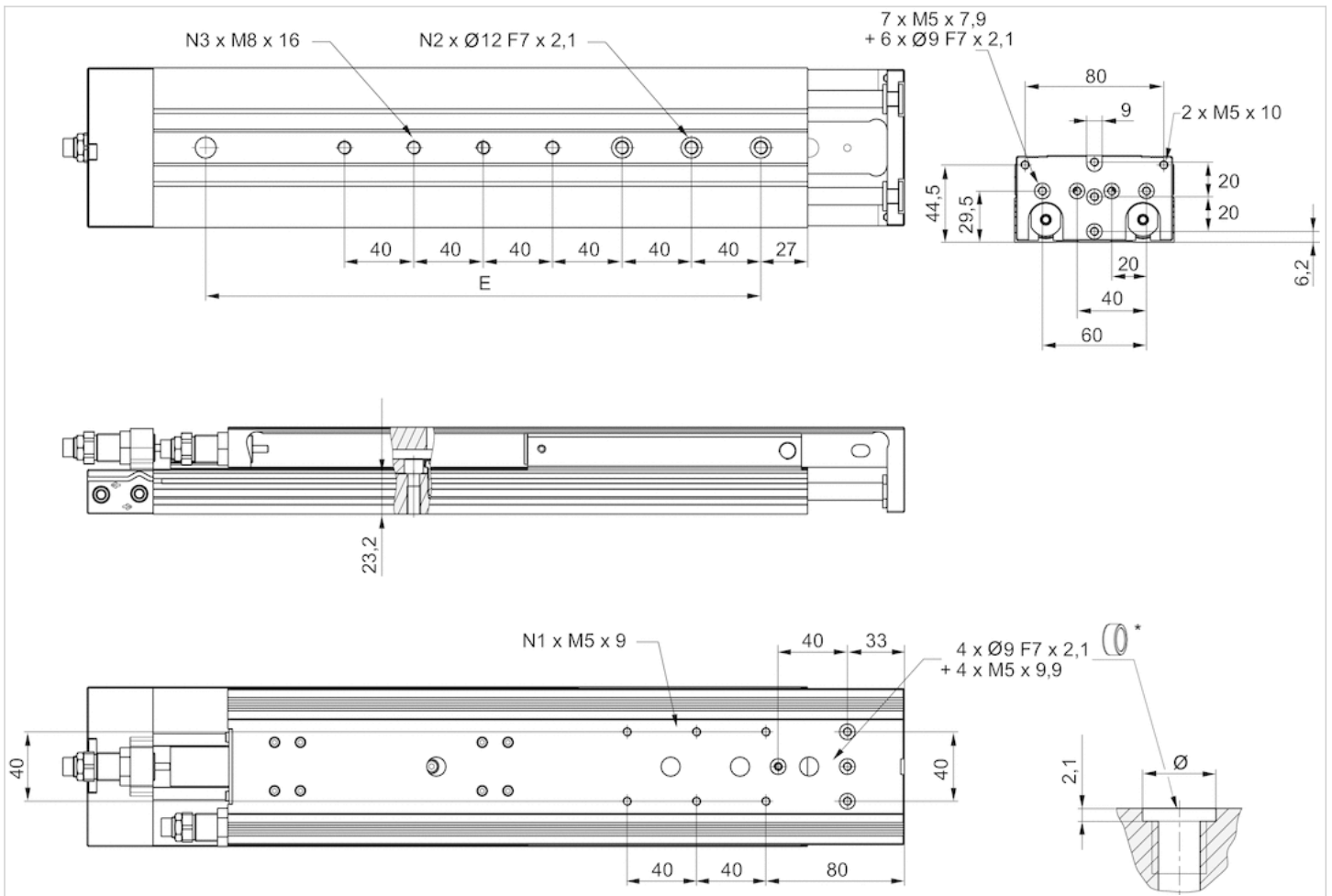

* = centering rings

Dimensions

Piston Ø	Stroke	E	N1	N2	N3
20 mm	125	200	6	4	5
20 mm	150	240	6	4	5
20 mm	200	320	6	4	7

Dimensions

MSC-25

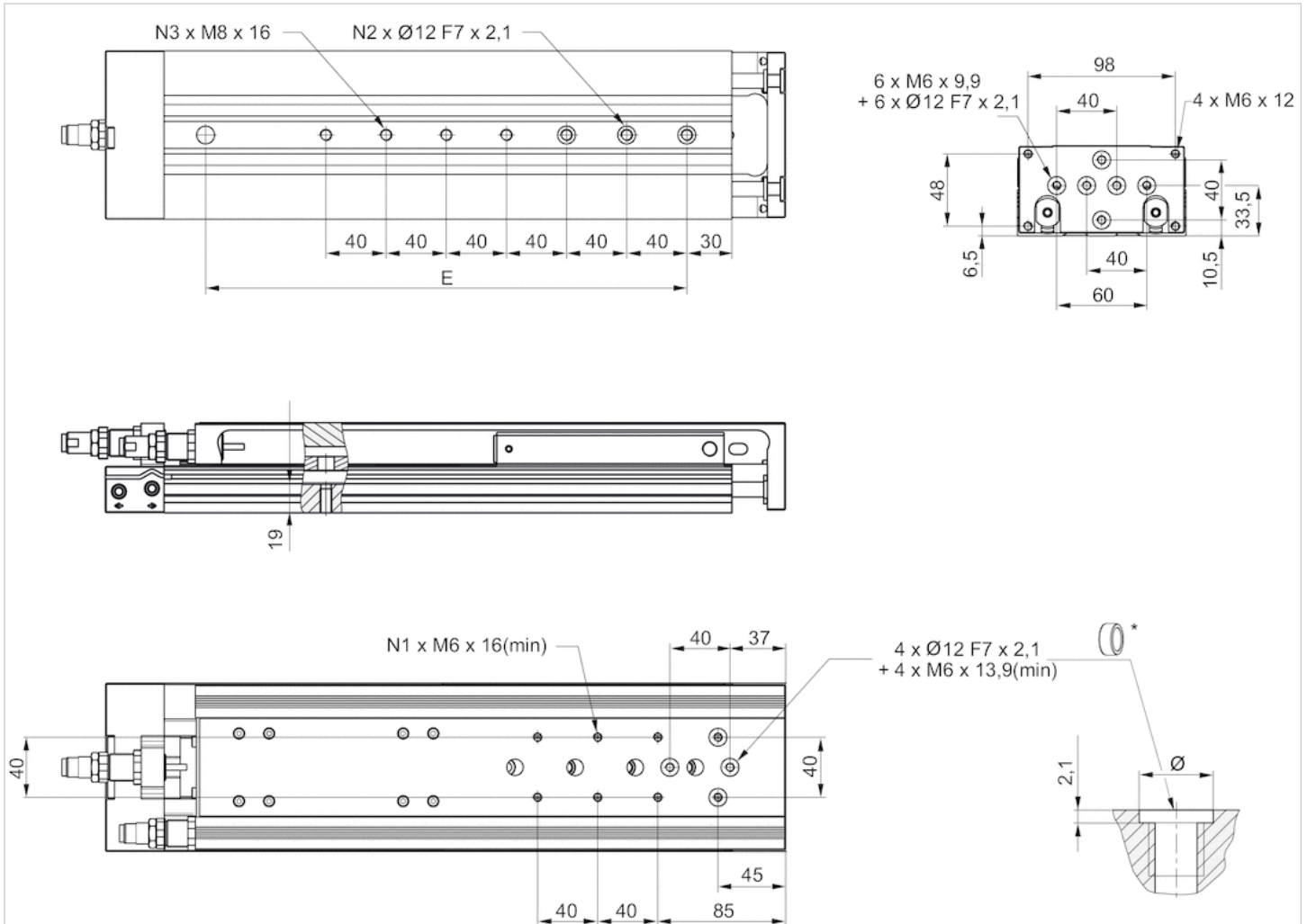

* = centering rings

Dimensions

Piston \varnothing	Stroke	E	N1	N2	N3
25 mm	125	200	4	4	5
25 mm	150	240	6	4	5
25 mm	200	320	6	4	7

Weight of moving parts [kg]

Piston \varnothing	S=125	S=150	S=200
16 mm	0.725	0.765	–
20 mm	1.2	1.29	1.54
25 mm	1.885	2.085	2.445

S = stroke

Weight [kg]

Piston Ø	S	Weight kg
16 mm	50	1.29 kg
16 mm	80	1.37 kg
16 mm	100	1.94 kg
16 mm	125	1.94 kg
16 mm	150	2.08 kg
20 mm	50	1.61 kg
20 mm	80	2.1 kg
20 mm	100	2.23 kg
20 mm	125	3.02 kg
20 mm	150	3.36 kg
20 mm	200	4.12 kg
25 mm	50	2.64 kg
25 mm	80	3.29 kg
25 mm	100	3.56 kg
25 mm	125	4.75 kg
25 mm	150	5.37 kg
25 mm	200	6.46 kg

S = stroke

Load capacity

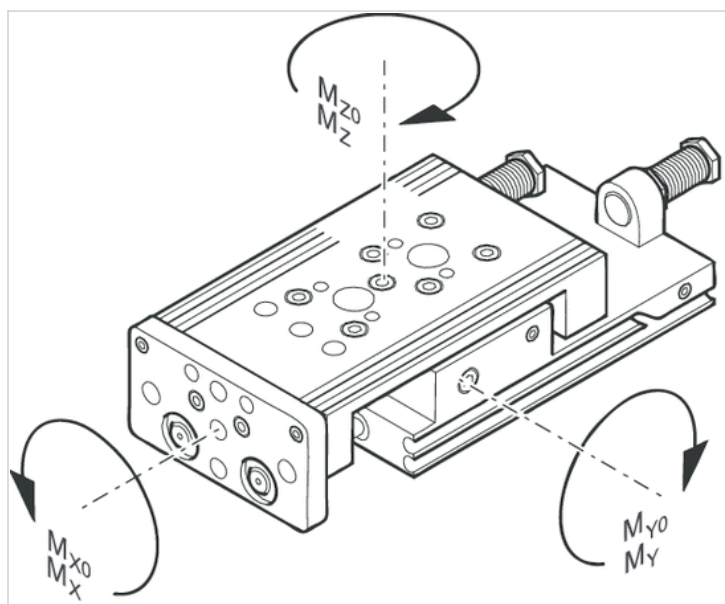

M = max. permissible torque

correction factor (a)

Piston Ø	S	a [mm] 1)	d [mm] 2)	Mx0 Static moment M [Nm]
16 mm	50	85,5	15	38
20 mm	50	90.5	20	93
25 mm	50	96.5	24	100

My0 Static moment M [Nm]	Mz0 Static moment M [Nm]	Mx Dynamic moment M [Nm]
29	29	7
65	65	10
90	90	15.3

My Dynamic moment M [Nm]	Mz Dynamic moment M [Nm]
7,6	7,6
13.3	13.3
13	13

correction factor (a, d)

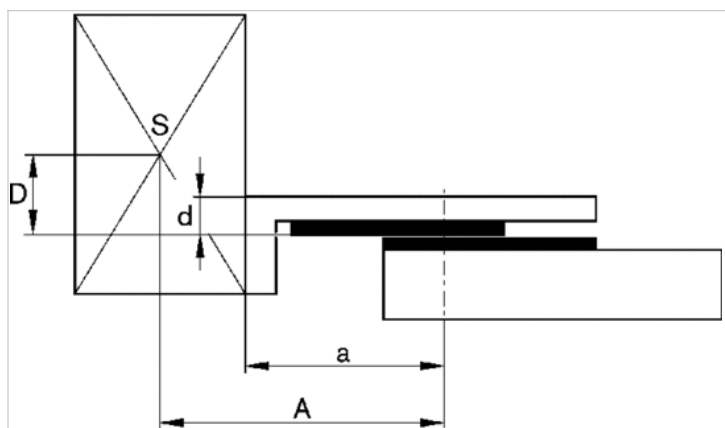

horizontal

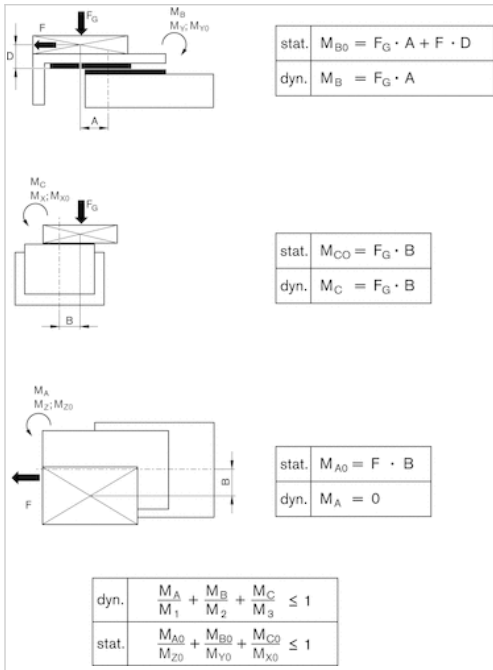

$F = m \cdot a$
 $FG = m \cdot g$
 $a = 1250 \cdot V^2 / H$

- F = deceleration force [N]
- FG= force due to weight [N]
- m = load mass [kg]
- a = deceleration [m/s²]
- g = gravitational acceleration 9,81 [m/s²]
- V = velocity [m/s]
- H = stroke length of shock absorber [mm]

vertical

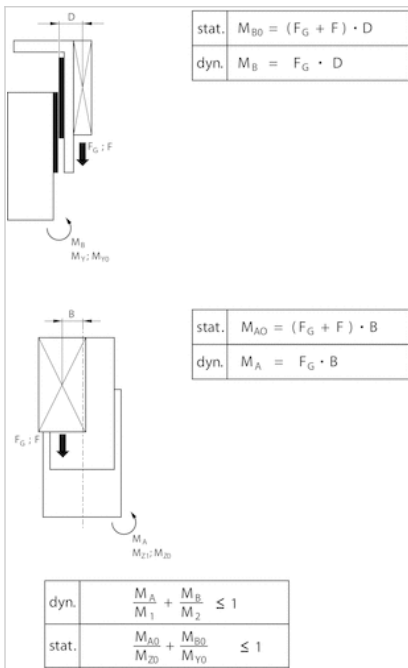

$F = m \cdot a$
 $FG = m \cdot g$

$$a = 1250 \cdot V^2 / H$$

F = deceleration force [N]

FG = force due to weight [N]

m = load mass [kg]

a = deceleration [m/s²]

g = gravitational acceleration 9,81 [m/s²]

V = velocity [m/s]

H = stroke length of shock absorber [mm]

Diagrams

Maximum moving mass

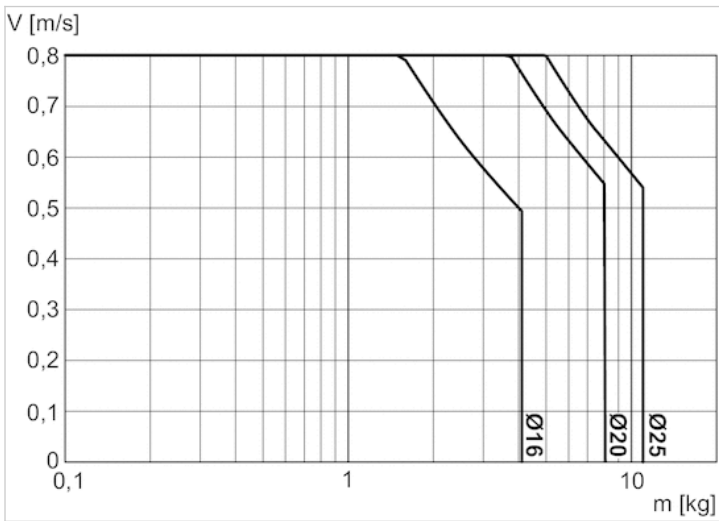

V = velocity [m/s]

m = mass

Correction factor for required speed: retracting and extending, horizontal

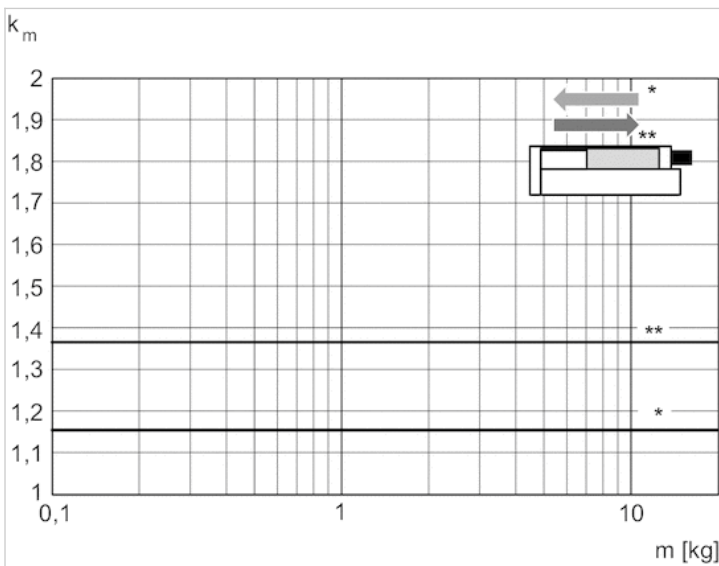

* retracting

** extracting

$$V = s / 1000 \cdot t \cdot k_m$$

V = velocity [m/s]

S = stroke

Correction factor for required speed: extending, vertical, upwards

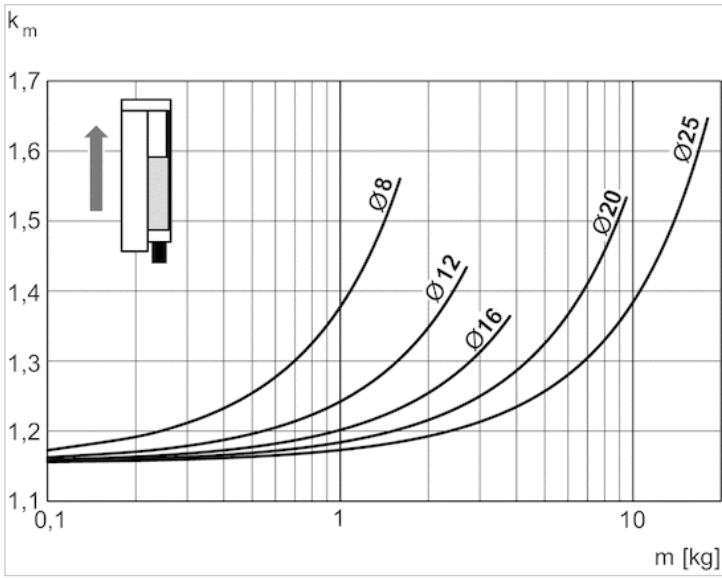

$V = s/1000 \cdot t \cdot k_m$
 $V = \text{velocity [m/s]}$
 $S = \text{stroke [mm]}$
 $t = \text{time [s] for one stroke}$
 $m = \text{mass}$

Correction factor for required speed: retracting, vertical, upwards

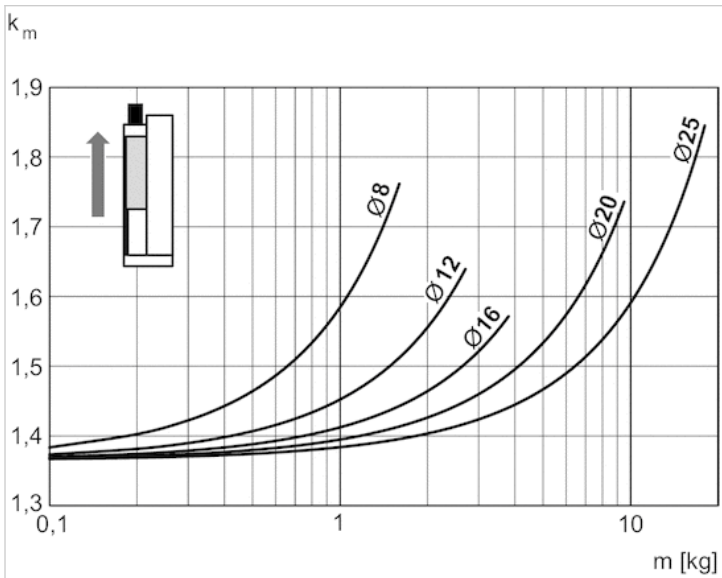

$V = s/1000 \cdot t \cdot k_m$
 $V = \text{velocity [m/s]}$
 $S = \text{stroke [mm]}$
 $t = \text{time [s] for one stroke}$
 $m = \text{mass}$

Correction factor for required speed: retracting, vertical, downwards

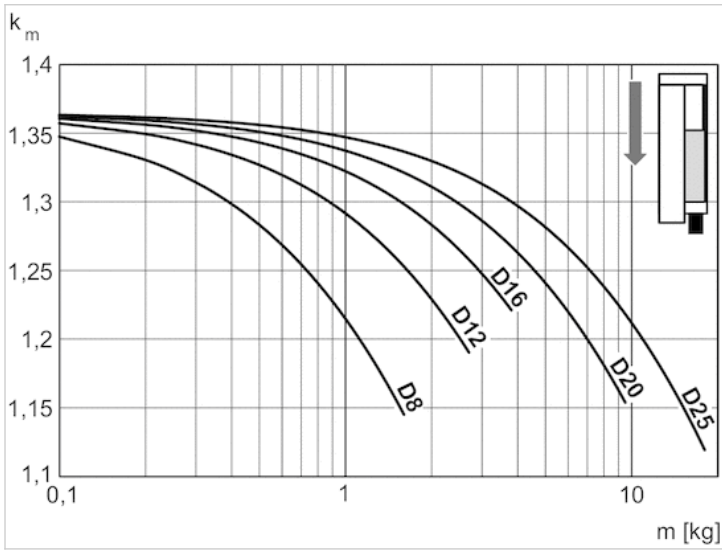

$V = s/1000 \cdot t \cdot k_m$
 V = velocity [m/s]
 S = stroke [mm]
 t = time [s] for one stroke
 m = mass

Correction factor for required speed: extending, vertical, downwards

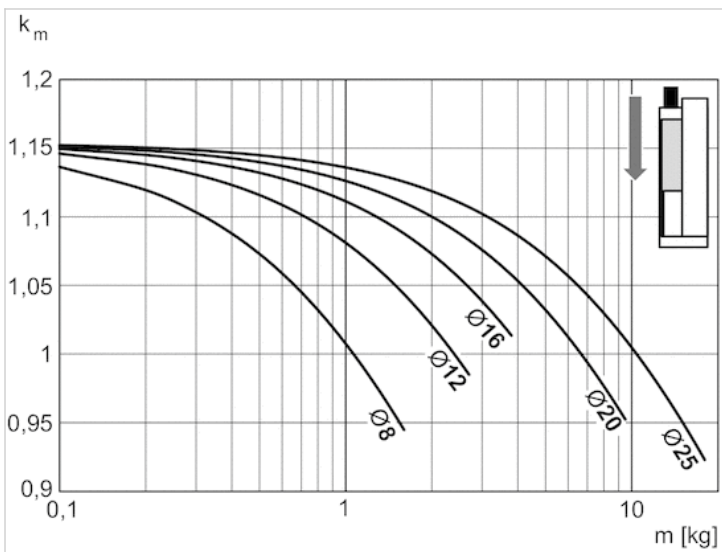

$V = s/1000 \cdot t \cdot k_m$
 V = velocity [m/s]
 S = stroke [mm]
 t = time [s] for one stroke
 m = mass

Extracting speed max.

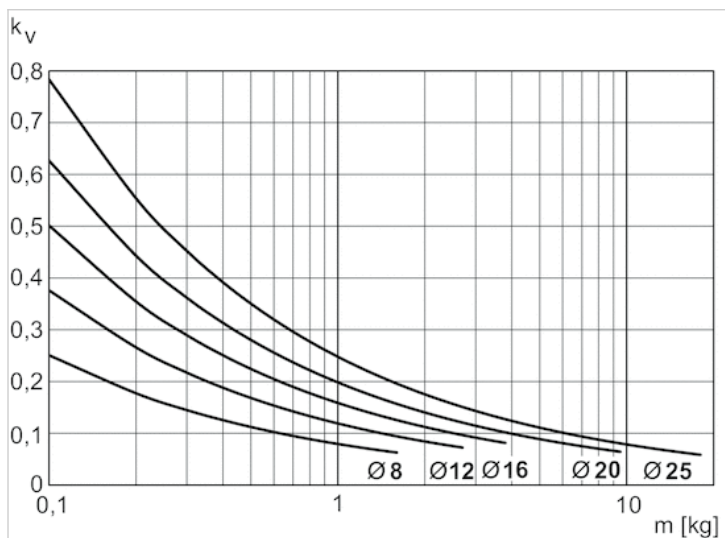

$V = \sqrt{s} \cdot kv$

V = velocity [m/s]

S = stroke [mm]

m = mass

Accessories overview

Overview drawing

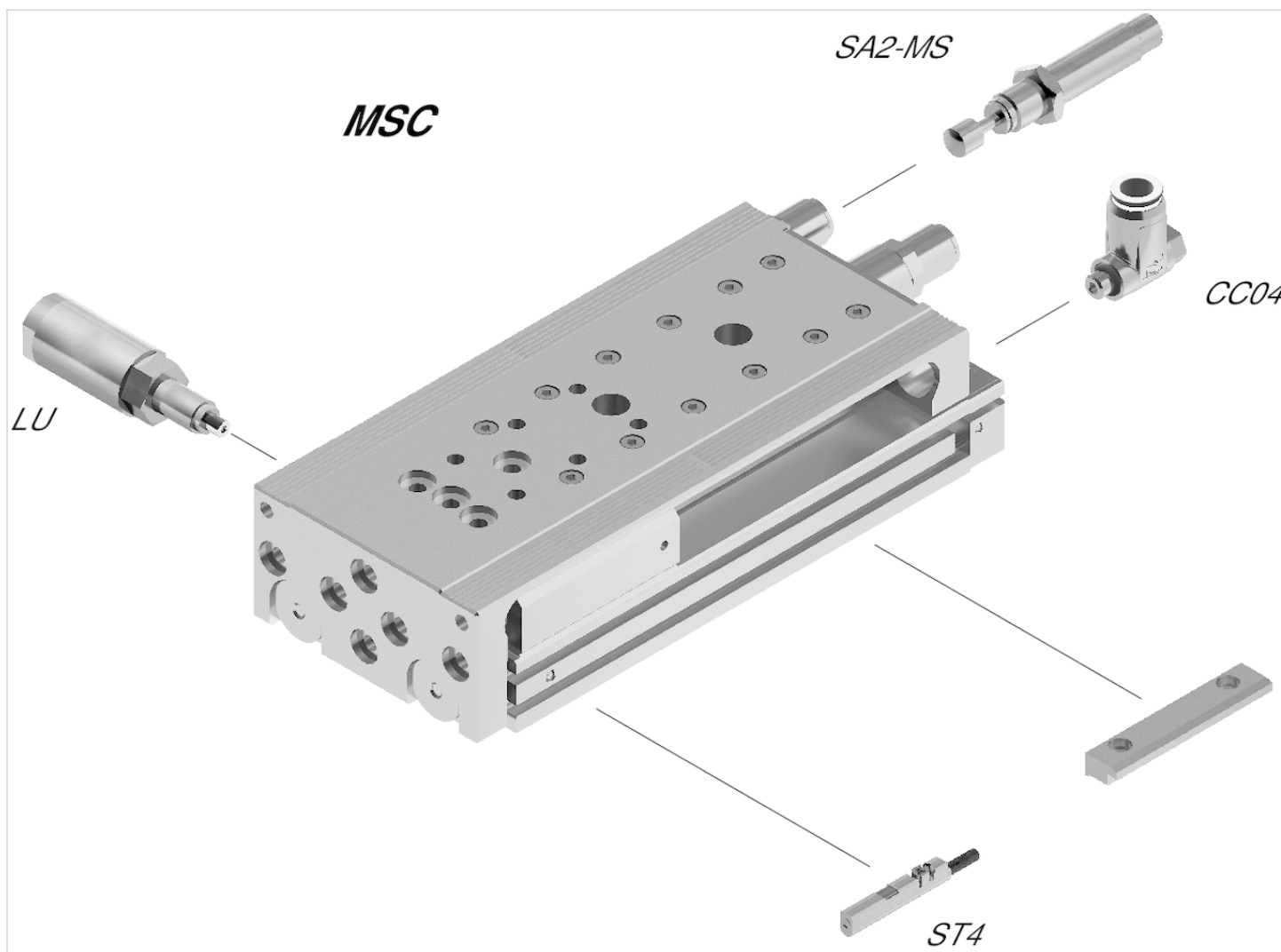

NOTE:

This overview drawing is only for orientation to indicate where the various accessory parts can be fastened to the cylinder. The illustration has been simplified for this purpose. It is thus not possible to derive the dimensions from this overview.

Mini slide, Series MSC-HG-HM

- Scope of delivery: incl. centering rings
- Ø 16-25 mm
- double-acting
- with magnetic piston
- Cushioning hydraulic
- Easy2Combine capable
- with double piston
- With integrated "High Performance" ball rail system



Working pressure min./max.	See table below
Ambient temperature min./max.	0 ... 60 °C
Medium	Compressed air
Max. particle size	5 µm
Oil content of compressed air	0 ... 1 mg/m³
Pressure for determining piston forces	6.3 bar
Repetitive precision	0,02 mm
Weight	See table below

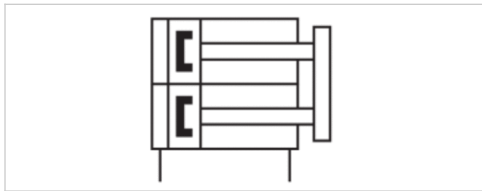

Technical data

Piston Ø	16 mm	20 mm	25 mm
Stroke 125	R412019188	R412019005	R412019041
150	R412019189	R412019006	R412019042
200	-	R412019007	R412019043

Technical data

Piston Ø 2x	16 mm	20 mm	25 mm
Working pressure min./max.	1 ... 10 bar	1 ... 10 bar	1 ... 10 bar
Retracting piston force, theoretical	218 N	297 N	520 N
Extracting piston force, theoretical	253 N	396 N	619 N
Speed max.	0.8 m/s	0.8 m/s	0.8 m/s
Cushioning length	7 mm	10 mm	14 mm
Cushioning energy	1.2 J	3.1 J	5.8 J

Technical information

The pressure dew point must be at least 15 °C under ambient and medium temperature and may not exceed 3 °C .

The oil content of compressed air must remain constant during the life cycle.

Use only the approved oils from AVENTICS. Further information can be found in the "Technical information" document (available in the MediaCentre).

Repetitive precision after 100 consecutive strokes: 0,02 mm

Base with air connections at the back and sides

Intermediate strokes can be configured.

Scope of delivery: incl. centering rings

R1 = stroke setting range for forward stroke

R2 = stroke setting range for return stroke

Technical information

Material	
Housing	Aluminum, anodized
Piston rod	Stainless steel
Front plate	Aluminum, anodized
Seal	Polyurethane
Ball rail table	Aluminum, anodized
Guide rail	Steel, hardened
Centering rings	Stainless steel

Dimensions

Dimensions

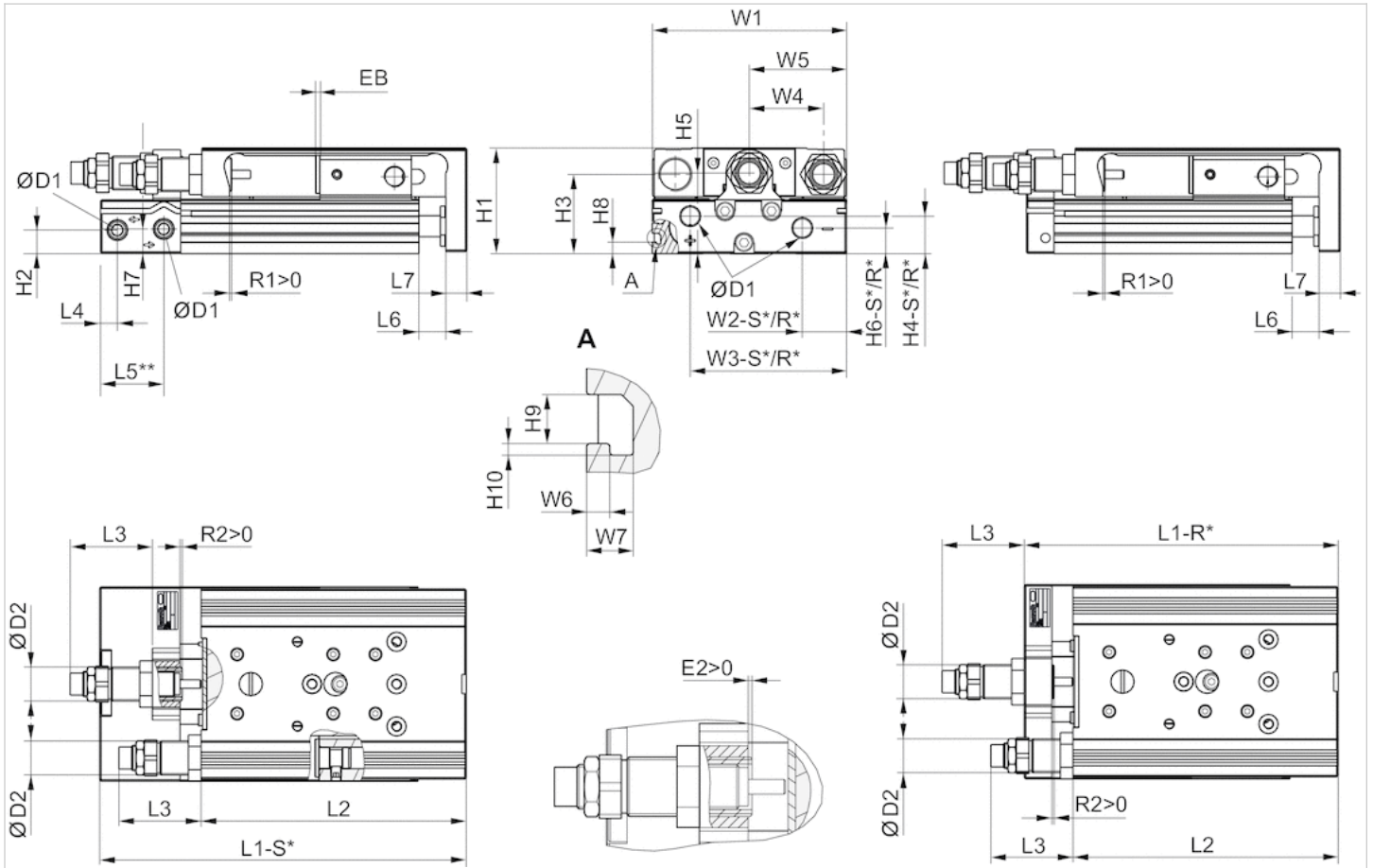

R*: base with air connections only at the back
 S*: base with air connections at the back and sides

Dimensions

Piston Ø	Ø D1	Ø D	H1	H2	H3	H4-R	H4-S	H5	H6-R	H6-S	H7	H8	H9	H10	L3 max.	L4
16 mm	M5	M12x1	40	7.2	29	12.2	12.2	31	7.7	7.7	11.2	-	-	-	44.9	6.5
20 mm	G 1/8	M16x1,5	50	11.2	37.5	17.3	17.3	38.2	11.7	12.2	11.7	5.5	4.2	1	48.9	8
25 mm	G 1/8	M18x1,5	60	14.2	44	15.5	22.9	46.5	13.2	21.7	16.2	6.9	5.2	1.5	67.7	9

Piston Ø	L5 2)	L6	L7	R2	W1	W2-R	W2-S	W3-R	W3-S	W4	W5	W6	W7
16 mm	17.7	2	10	10.4	76	31	31	60.5	60.5	30	W1/2	-	-
20 mm	30	2.1	10	14	92	10	21	74	74	35	W1/2	2	4
25 mm	31	2.1	12	16.2	112	11	14	92	92	44	W1/2	2.5	4.8

Stroke-dependent dimensions

Piston Ø	S=125 EB	S=150 EB	S=200 EB	S=125 L1-R	S=150 L1-R	S=200 L1-R
16 mm	2	2	–	281.3	306.3	–
20 mm	2	2	2	287.4	327.4	402.4
25 mm	2	2	2	292.1	332.1	407.1

Piston Ø	S=125 L1-S	S=150 L1-S	S=200 L1-S	S=125 L2	S=150 L2	S=200 L2
16 mm	292.2	317.2	–	269.9	294.9	–
20 mm	312.3	352.3	427.3	275	315	390
25 mm	315.8	355.8	430.8	277.5	317.5	392.5

Dimensions

MSC-16

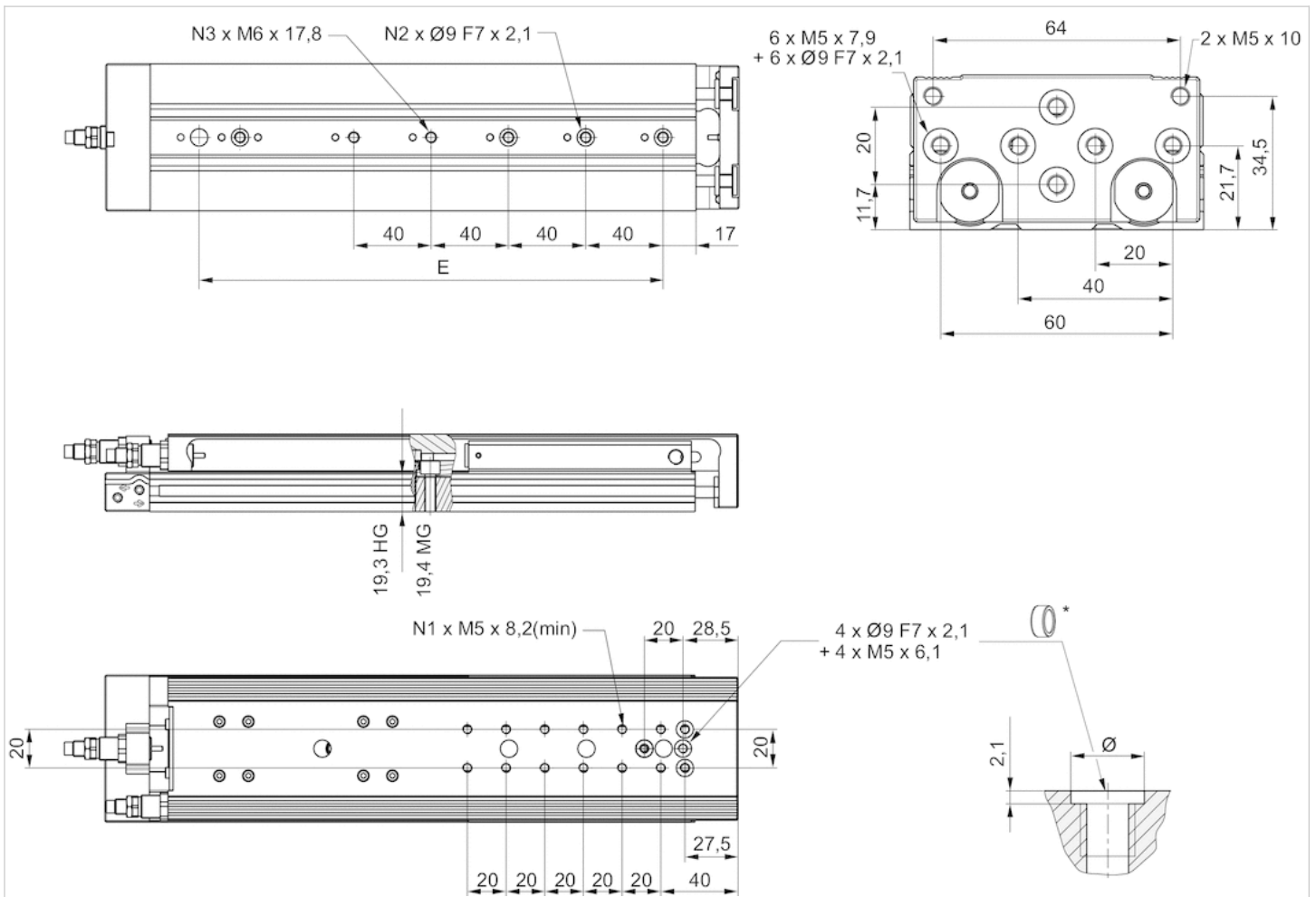

* = centering rings

Dimensions

Piston \varnothing	Stroke	E	N1	N2	N3
16 mm	125	200	12	4	5
16 mm	150	240	12	4	5

Dimensions

MSC-20

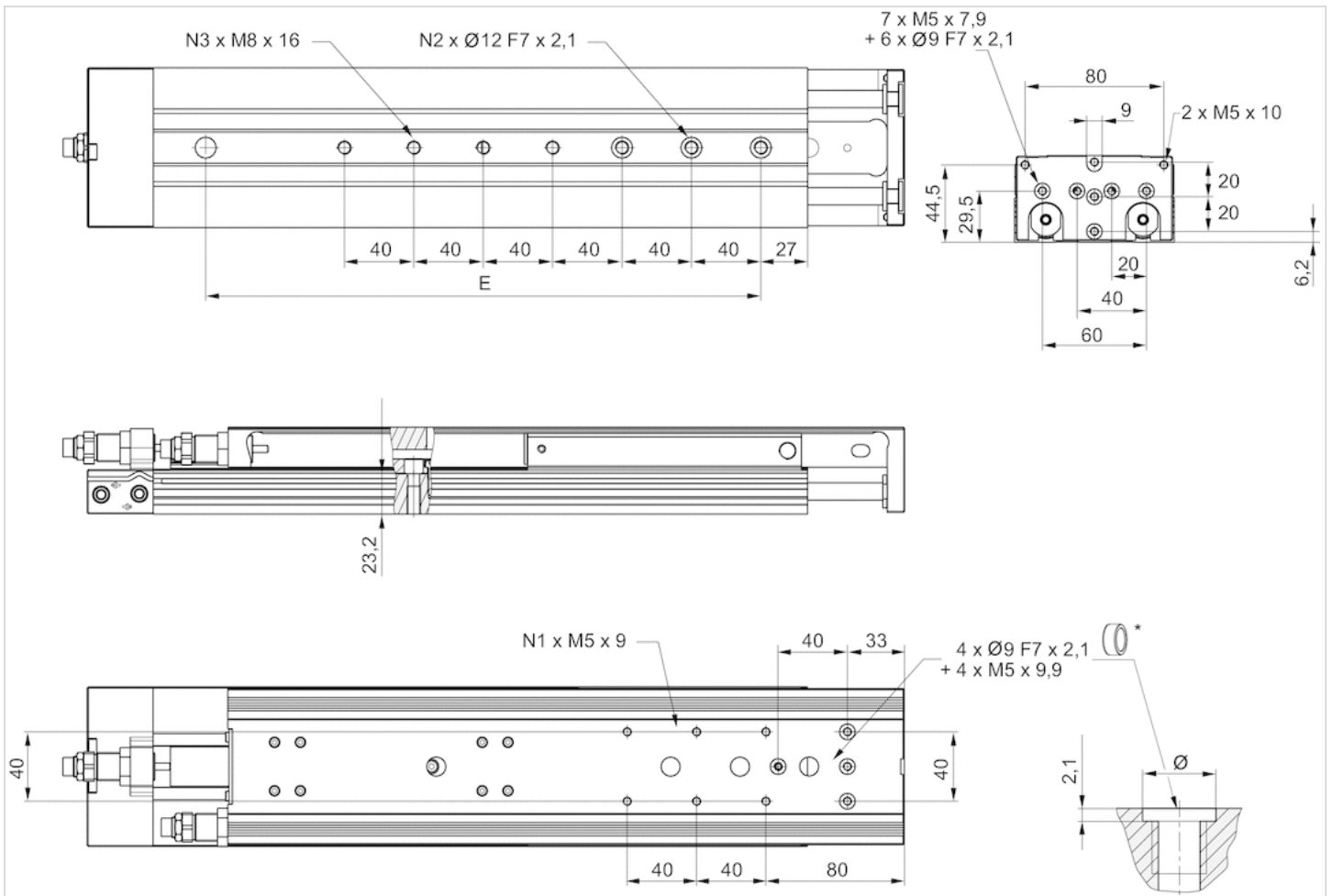

* = centering rings

Dimensions

Piston Ø	Stroke	E	N1	N2	N3
20 mm	125	200	6	4	5
20 mm	150	240	6	4	5
20 mm	200	320	6	4	7

Dimensions

MSC-25

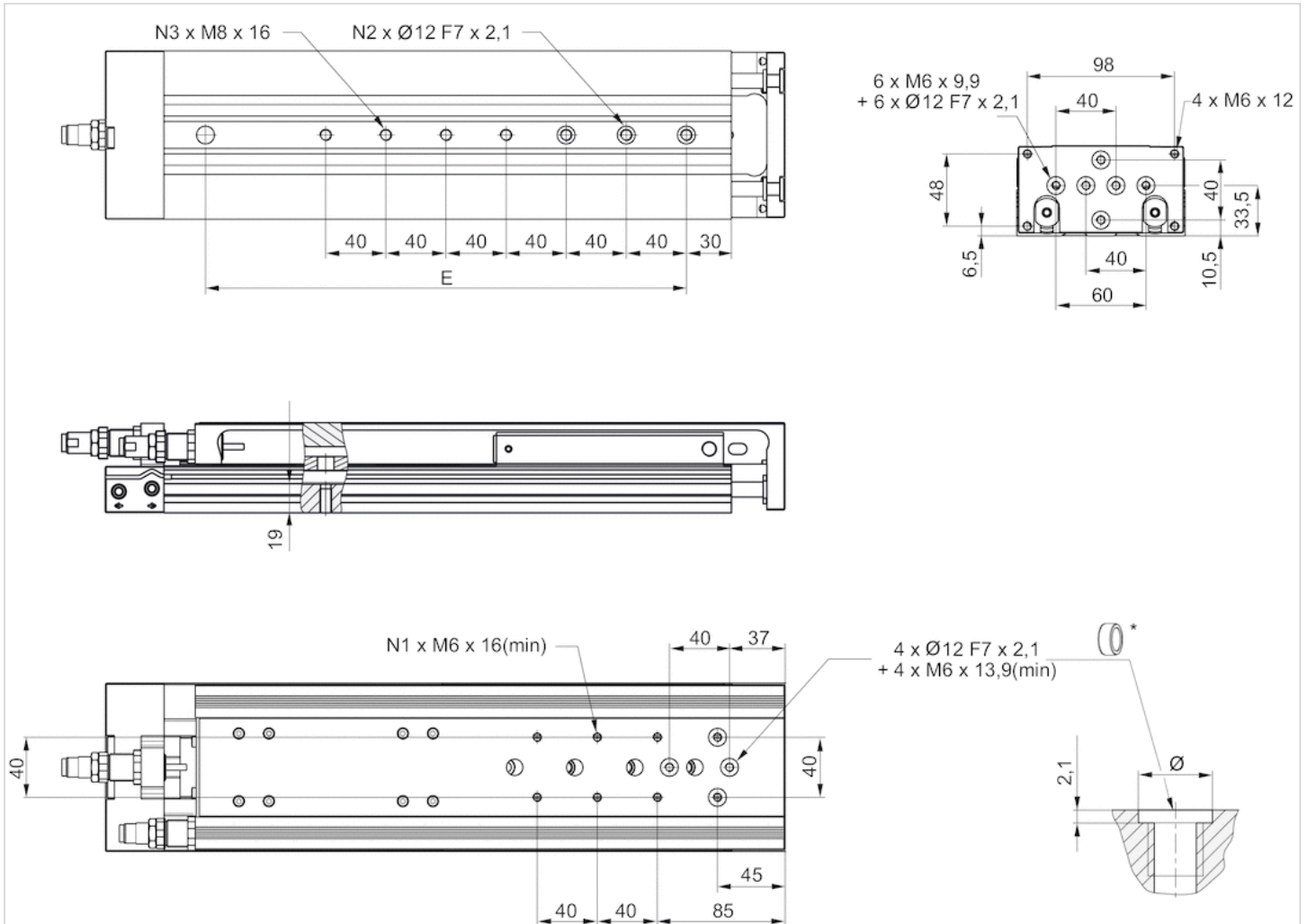

* = centering rings

Dimensions

Piston \varnothing	Stroke	E	N1	N2	N3
25 mm	125	200	4	4	5
25 mm	150	240	6	4	5
25 mm	200	320	6	4	7

Weight of moving parts [kg]

Piston Ø	S=125	S=150	S=200
16 mm	0.725	0.765	–
20 mm	1.2	1.29	1.54
25 mm	1.885	2.085	2.445

Weight [kg]

Piston Ø	Stroke	Weight kg
16 mm	125	1.94 kg
16 mm	150	2.08 kg
20 mm	125	3.02 kg
20 mm	150	3.36 kg
20 mm	200	4.12 kg
25 mm	125	4.75 kg
25 mm	150	5.37 kg
25 mm	200	6.46 kg

Load capacity

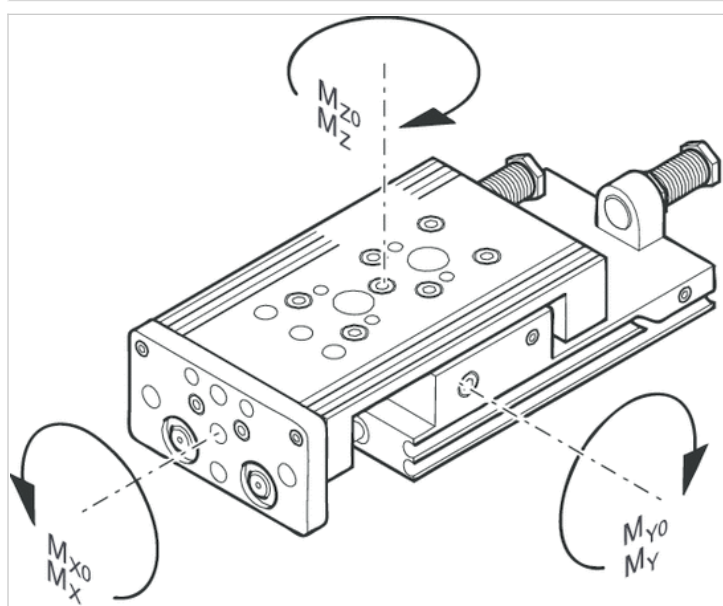

M = max. permissible torque

correction factor (a)

Piston Ø	S	a [mm]	d [mm]	Mx0 Static moment M [Nm]	My0 Static moment M [Nm]
16 mm	125	198.5	15	88	118
16 mm	150	223.5	15	88	119
20 mm	100	150.5	20	116	99
20 mm	125	201	20	126	136
20 mm	150	233.5	20	126	152
20 mm	200	296	20	126	179
25 mm	125	201	24	145	180
25 mm	150	236.5	24	145	201
25 mm	200	299	24	145	236

Piston Ø	Mz0 Static moment [Nm]	Mx Dynamic Moment M [Nm]	My Dynamic Moment M [Nm]
16 mm	118	15.2	31.2
16 mm	119	15.2	31.2
20 mm	136	19	40.6
20 mm	152	19	45.4
20 mm	179	19	53.4
25 mm	180	20.4	44.1
25 mm	201	20.4	49.2
25 mm	236	20.4	57.8

Piston Ø	Mz Dynamic Moment M [Nm]
16 mm	31.2
16 mm	31.2
20 mm	40.6
20 mm	45.4
20 mm	53.4
25 mm	44.1
25 mm	49.2
25 mm	57.8

correction factor (a, d)

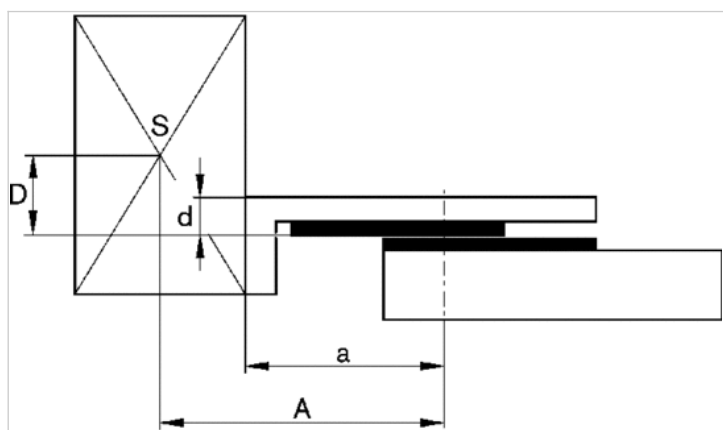

horizontal

stat.	$M_{B0} = F_G \cdot A + F \cdot D$
dyn.	$M_B = F_G \cdot A$

stat.	$M_{C0} = F_G \cdot B$
dyn.	$M_C = F_G \cdot B$

stat.	$M_{A0} = F \cdot B$
dyn.	$M_A = 0$

dyn.	$\frac{M_A}{M_1} + \frac{M_B}{M_2} + \frac{M_C}{M_3} \leq 1$
stat.	$\frac{M_{A0}}{M_{Z0}} + \frac{M_{B0}}{M_{Y0}} + \frac{M_{C0}}{M_{X0}} \leq 1$

$F = m \cdot a$
 $FG = m \cdot g$
 $a = 1250 \cdot V^2 / H$

- F = deceleration force [N]
- FG= force due to weight [N]
- m = load mass [kg]
- a = deceleration [m/s²]
- g = gravitational acceleration 9,81 [m/s²]
- V = velocity [m/s]
- H = stroke length of shock absorber [mm]

vertical

stat.	$M_{B0} = (F_G + F) \cdot D$
dyn.	$M_B = F_G \cdot D$

stat.	$M_{A0} = (F_G + F) \cdot B$
dyn.	$M_A = F_G \cdot B$

dyn.	$\frac{M_A}{M_1} + \frac{M_B}{M_2} \leq 1$
stat.	$\frac{M_{A0}}{M_{Z0}} + \frac{M_{B0}}{M_{Y0}} \leq 1$

$F = m \cdot a$
 $FG = m \cdot g$

$$a = 1250 \cdot V^2 / H$$

F = deceleration force [N]

FG = force due to weight [N]

m = load mass [kg]

a = deceleration [m/s²]

g = gravitational acceleration 9,81 [m/s²]

V = velocity [m/s]

H = stroke length of shock absorber [mm]

Diagrams

Minimum and maximum moving mass

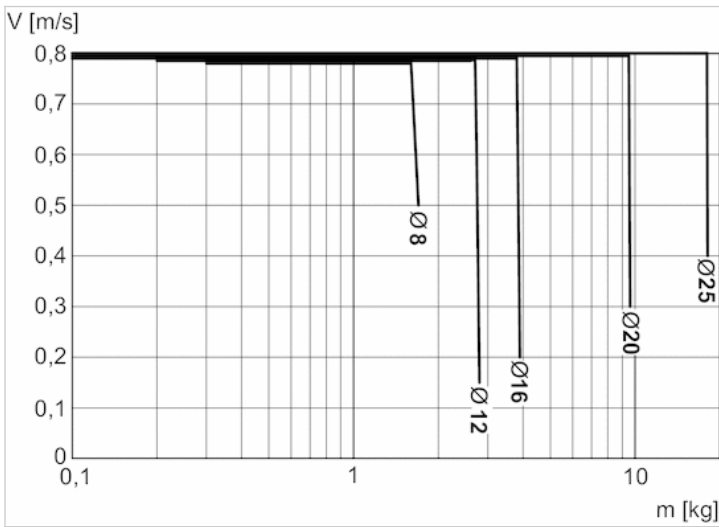

V = velocity [m/s]

m = mass

Correction factor for required speed: retracting and extending, horizontal

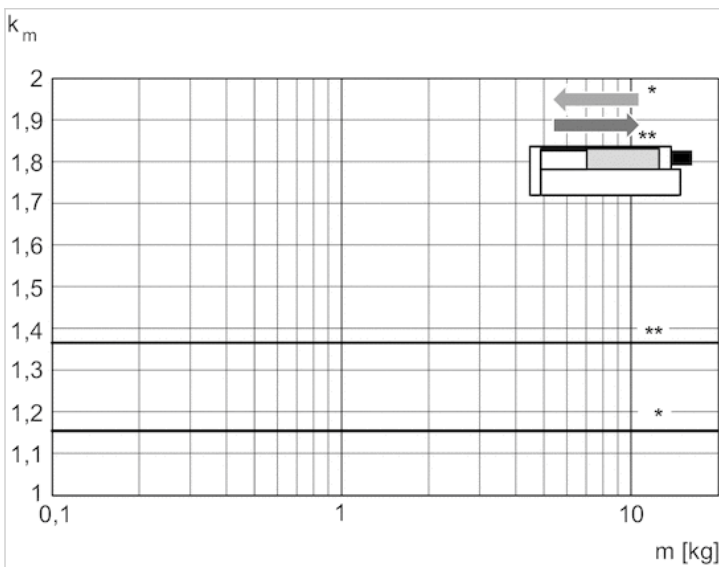

* retracting

** extracting

$$V = s / 1000 \cdot t \cdot km$$

V = velocity [m/s]

S = stroke

Max. additional moving mass, horizontal

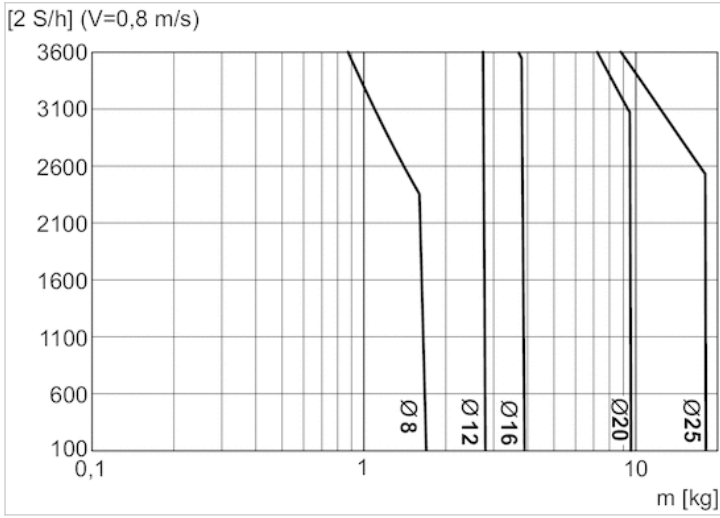

S = stroke [mm]
 2 x S = 1 cycle
 V = velocity [m/s]
 m = mass

Max. additional moving mass, vertical

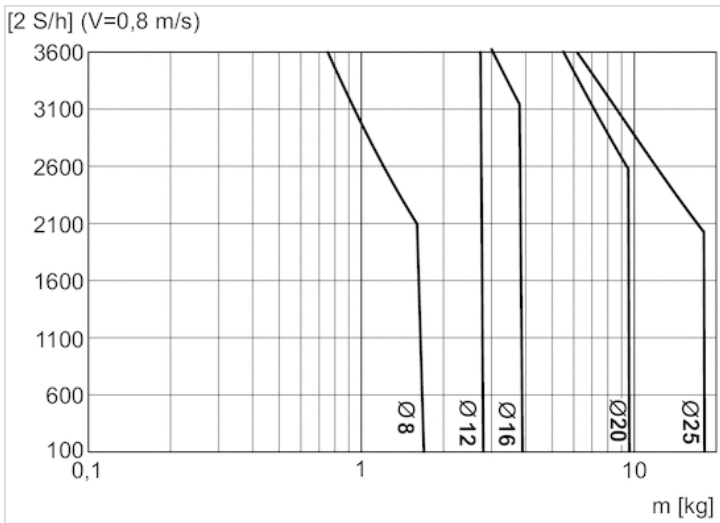

S = stroke [mm]
 2 x S = 1 cycle
 V = velocity [m/s]
 m = mass

Correction factor for required speed: extending, vertical, upwards

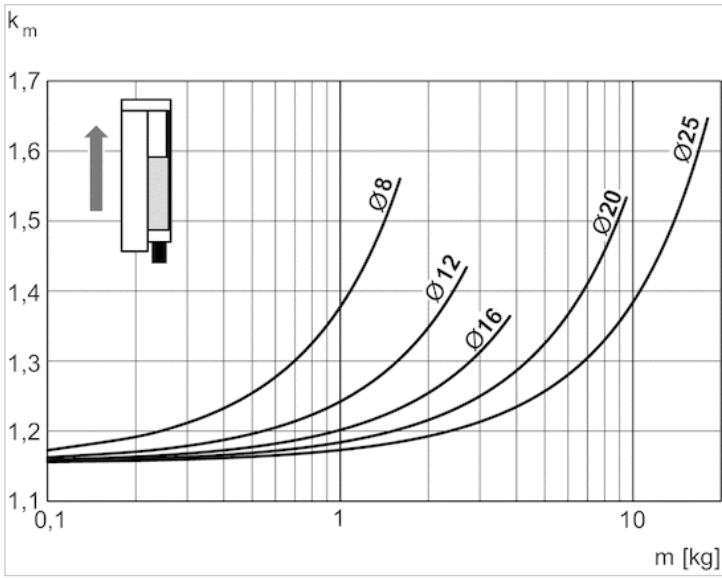

$V = s/1000 \cdot t \cdot k_m$
 $V = \text{velocity [m/s]}$
 $S = \text{stroke [mm]}$
 $t = \text{time [s] for one stroke}$
 $m = \text{mass}$

Correction factor for required speed: retracting, vertical, upwards

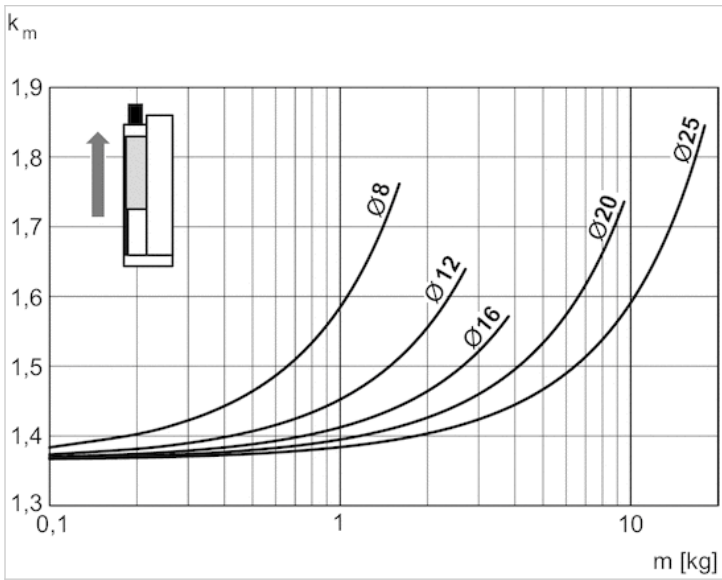

$V = s/1000 \cdot t \cdot k_m$
 $V = \text{velocity [m/s]}$
 $S = \text{stroke [mm]}$
 $t = \text{time [s] for one stroke}$
 $m = \text{mass}$

Correction factor for required speed: retracting, vertical, downwards

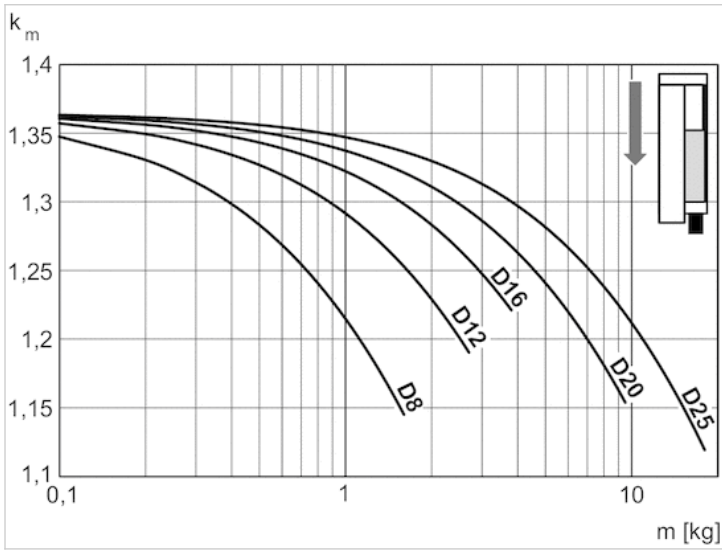

$V = s/1000 \cdot t \cdot k_m$
 $V =$ velocity [m/s]
 $S =$ stroke [mm]
 $t =$ time [s] for one stroke
 $m =$ mass

Correction factor for required speed: extending, vertical, downwards

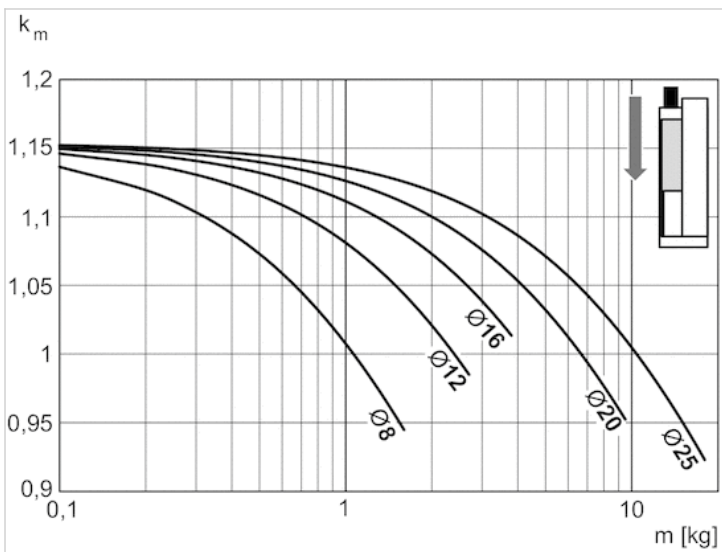

$V = s/1000 \cdot t \cdot k_m$
 $V =$ velocity [m/s]
 $S =$ stroke [mm]
 $t =$ time [s] for one stroke
 $m =$ mass

Extracting speed max.

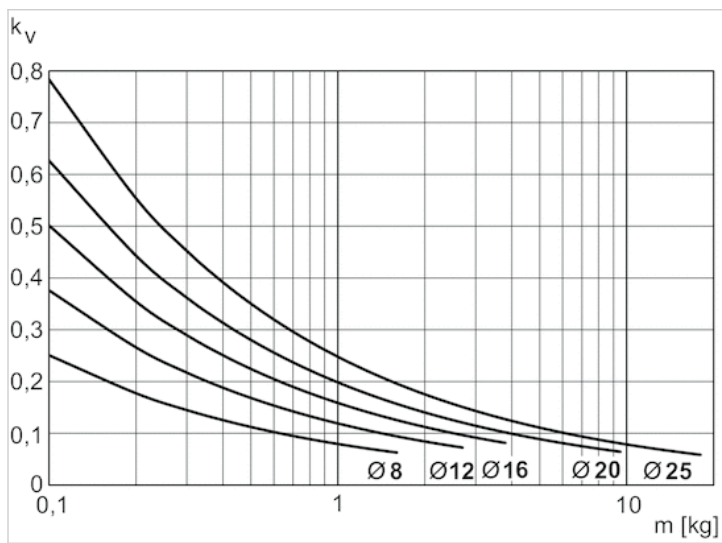

$$V = \sqrt{s} \cdot kv$$

V = velocity [m/s]

S = stroke [mm]

m = mass

Accessories overview

Overview drawing

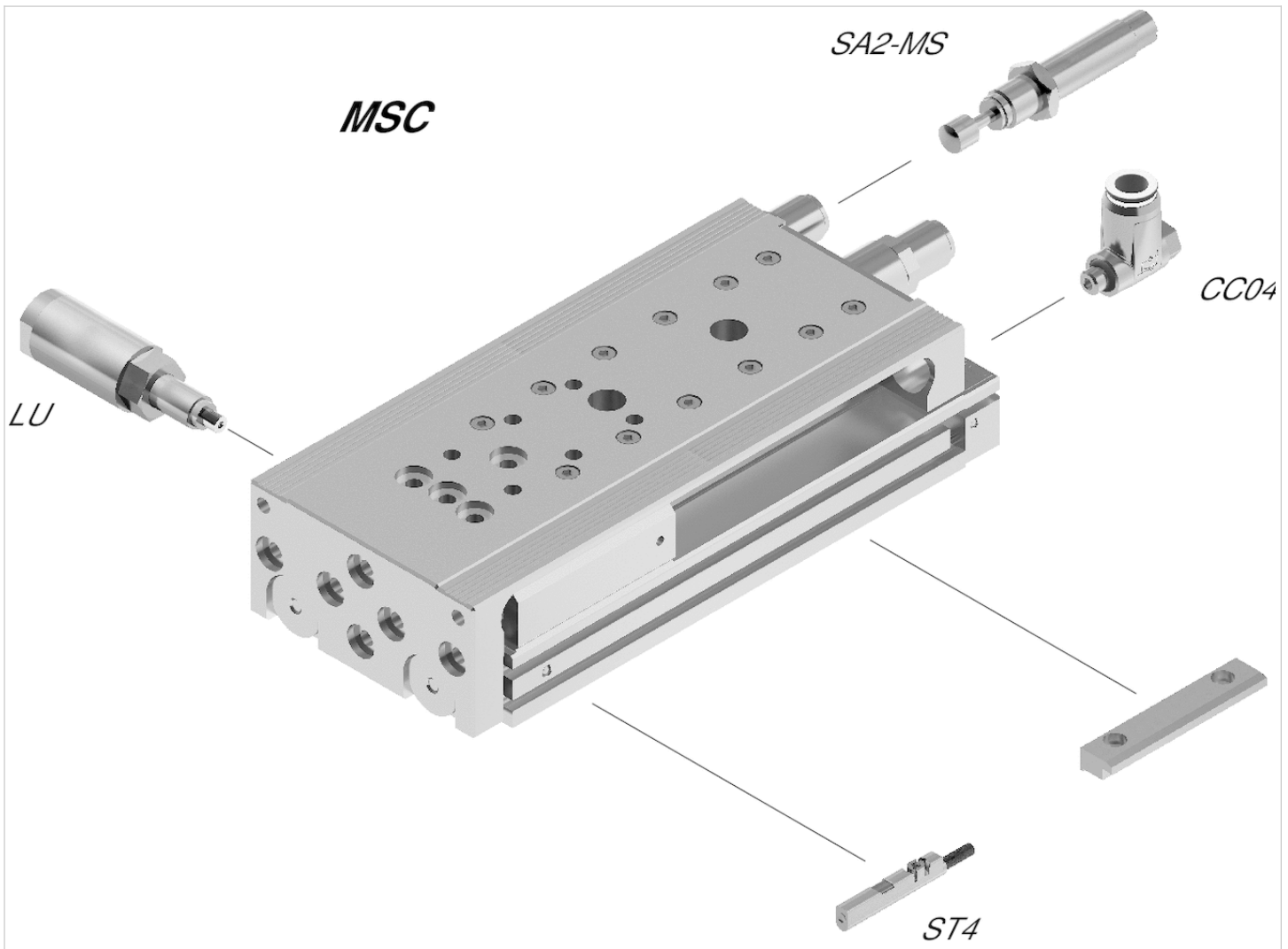

NOTE:

This overview drawing is only for orientation to indicate where the various accessory parts can be fastened to the cylinder. The illustration has been simplified for this purpose. It is thus not possible to derive the dimensions from this overview.

Mini slide, Series MSC-MG-EE

- Scope of delivery: incl. centering rings
- Ø 8-25 mm
- double-acting
- with magnetic piston
- Cushioning elastic
- Easy2Combine capable
- with double piston
- With integrated ball rail system

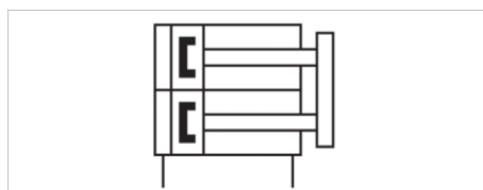

Working pressure min./max.	See table below
Ambient temperature min./max.	0 ... 60 °C
Medium	Compressed air
Max. particle size	5 µm
Oil content of compressed air	0 ... 1 mg/m ³
Pressure for determining piston forces	6.3 bar
Repetitive precision	0,3 mm
Weight	See table below

Technical data

Piston Ø	8 mm	12 mm	16 mm	20 mm	25 mm
Stroke 10	R480640120	R480640126	R480640133	R480640140	R480640147
20	R480640121	R480640127	R480640134	R480640141	R480640148
30	R480640122	R480640128	R480640135	R480640142	R480640149
40	R480640123	R480640129	R480640136	R480640143	R480640150
50	R480640124	R480640130	R480640137	R480640144	R480640151
80	R480640125	R480640131	R480640138	R480640145	R480640152
100	-	R480640132	R480640139	R480640146	R480640153

Technical data

Piston Ø 2x	8 mm	12 mm	16 mm	20 mm
Working pressure min./max.	1.5 ... 10 bar	1 ... 10 bar	1 ... 10 bar	1 ... 10 bar
Retracting piston force, theoretical	48 N	107 N	218 N	297 N
Extracting piston force, theoretical	63 N	143 N	253 N	396 N
Speed max.	0.8 m/s	0.8 m/s	0.8 m/s	0.8 m/s
Cushioning length	0.3 mm	0.75 mm	1 mm	1.2 mm
Cushioning energy	0.06 J	0.06 J	0.3 J	0.4 J

Piston Ø 2x	25 mm
Working pressure min./max.	1 ... 10 bar
Retracting piston force, theoretical	520 N
Extracting piston force, theoretical	619 N
Speed max.	0.8 m/s
Cushioning length	1.6 mm
Cushioning energy	0.5 J

Technical information

The pressure dew point must be at least 15 °C under ambient and medium temperature and may not exceed 3 °C .

The oil content of compressed air must remain constant during the life cycle.

Use only the approved oils from AVENTICS. Further information can be found in the "Technical information" document (available in the MediaCentre).

Repetitive precision after 100 consecutive strokes: 0,3 mm

Base with air connections at the back and sides

Intermediate strokes can be configured.

Scope of delivery: incl. centering rings

R1 = stroke setting range for forward stroke

R2 = stroke setting range for return stroke

Ø 8 has a different reference plane.

Technical information

Material	
Housing	Aluminum, anodized
Piston rod	Stainless steel
Front plate	Aluminum, anodized
Seal	Polyurethane
Ball rail table	Aluminum, anodized
Guide rail	Steel, hardened
Centering rings	Stainless steel

Dimensions

Dimensions

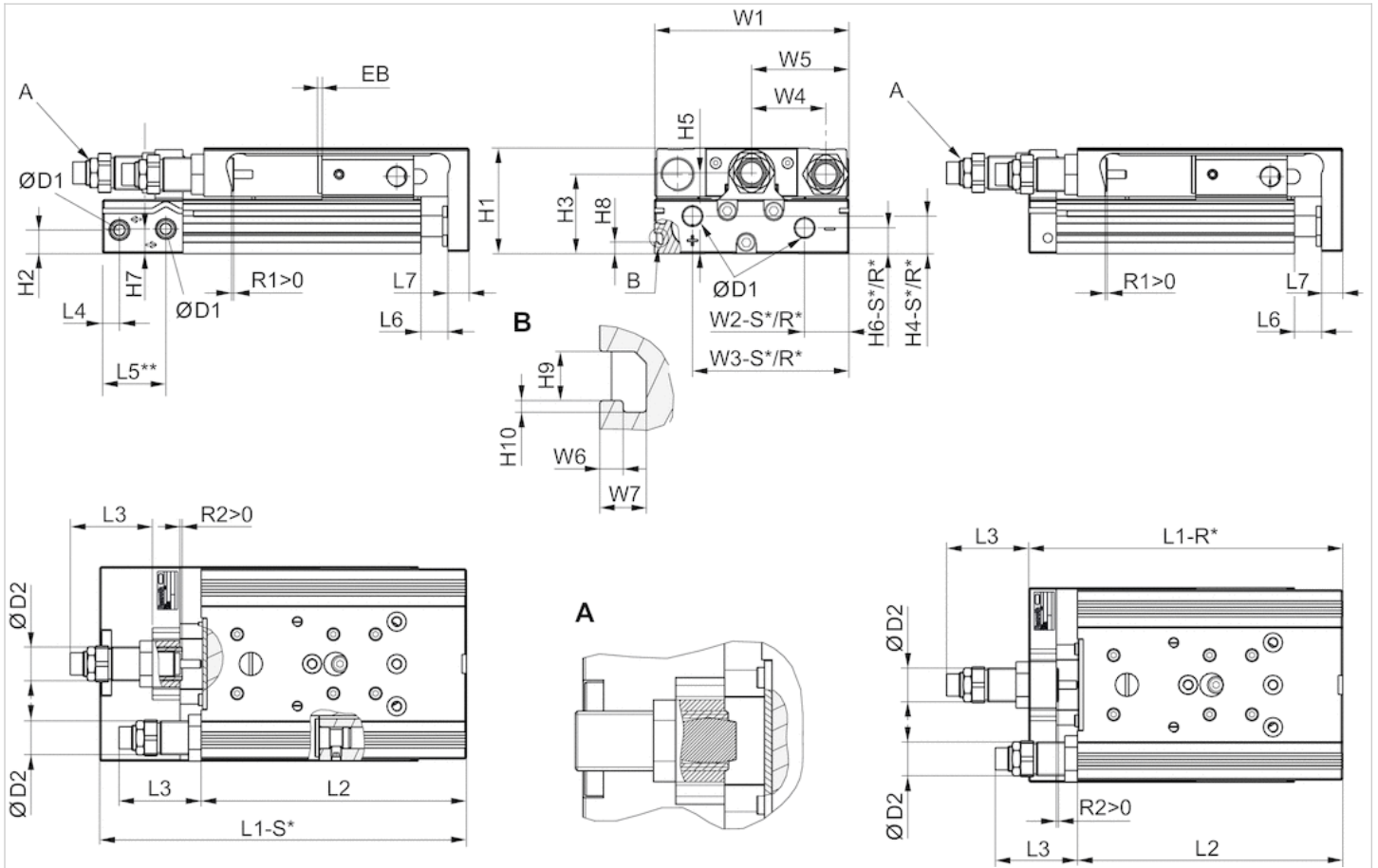

R*: base with air connections only at the back
 S*: base with air connections at the back and sides
 ** Ø 8 has a different reference plane.

Stroke-dependent dimensions

Piston Ø	S=10 EB	S=20 EB	S=30 EB	S=40 EB	S=50 EB	S=80 EB
8 mm	32	22	12	2	2	2

Piston Ø	S=100 EB	S=10 L1-R	S=20 L1-R	S=30 L1-R	S=40 L1-R	S=50 L1-R
8 mm	-	-	-	-	-	-

Piston Ø	S=80 L1-R	S=100 L1-R	S=10 L1-S	S=20 L1-S	S=30 L1-S
8 mm	-	-	101.7	101.7	101.7

Piston Ø	S=40 L1-S	S=50 L1-S	S=80 L1-S	S=100 L1-S	S=10 L2	S=20 L2
8 mm	101.7	121.7	171.7	-	93.5	93.5

Piston Ø	S=30 L2	S=40 L2	S=50 L2	S=80 L2	S=100 L2	S=10 R1 max.
8 mm	93.5	93.5	113.5	163.5	-	9.2

Piston Ø	S=20 R1 max.	S=30 R1 max.	S=40 R1 max.	S=50 R1 max.
8 mm	9.2	9.2	9.2	9.2

Piston Ø	S=80 R1 max.	S=100 R1 max.	S=10 R2 max.	S=20 R2 max.
8 mm	9.2	-	4.5	4.5

Piston Ø	S=30 R2 max.	S=40 R2 max.	S=50 R2 max.	S=80 R2 max.
8 mm	4.5	4.5	4.5	4.5

Piston Ø	S=100 R2 max.
8 mm	-

Dimensions

Piston Ø	Ø D1	Ø D2	H1	H2	H3	H4-R	H4-S	H5	H6-R	H6-S	H7	H8	H9	H10	L3 max.	L4
8 mm	M5	M10x1	28	9.6	20.5	-	7.5	19.5	-	5.5	18	-	-	-	16	9.8
12 mm	M5	M12x1	34	5.7	25	11.2	11.2	24.5	5.7	5.7	8.3	-	-	-	20.2	7.2
16 mm	M5	M12x1	40	7.2	29	12.2	12.2	31	7.7	7.7	11.2	-	-	-	18.4	6.5
20 mm	G 1/8	M16x1,5	50	11.2	37.5	17.3	17.3	38.2	11.7	12.2	11.7	5.5	4.2	1	27.9	8
25 mm	G 1/8	M18x1,5	60	14.2	44	15.5	22.9	46.5	13.2	21.7	16.2	6.9	5.2	1.5	29.2	9

Piston Ø	L5 2)	L6	L7	W1	W2-R	W2-S	W3-R	W3-S	W4	W5	W6	W7
8 mm	-	1.9	6	50.2	-	19.3	-	30.5	18	W1/2	-	-
12 mm	22.5	2	8	66	28.8	28.8	53	53	24.5	W1/2	-	-
16 mm	17.7	2	10	76	31	31	60.5	60.5	30	W1/2	-	-
20 mm	30	2.1	10	92	10	21	74	74	35	W1/2	2	4
25 mm	31	2.1	12	112	11	14	92	92	44	W1/2	2.5	4.8

Dimensions

MSC-08

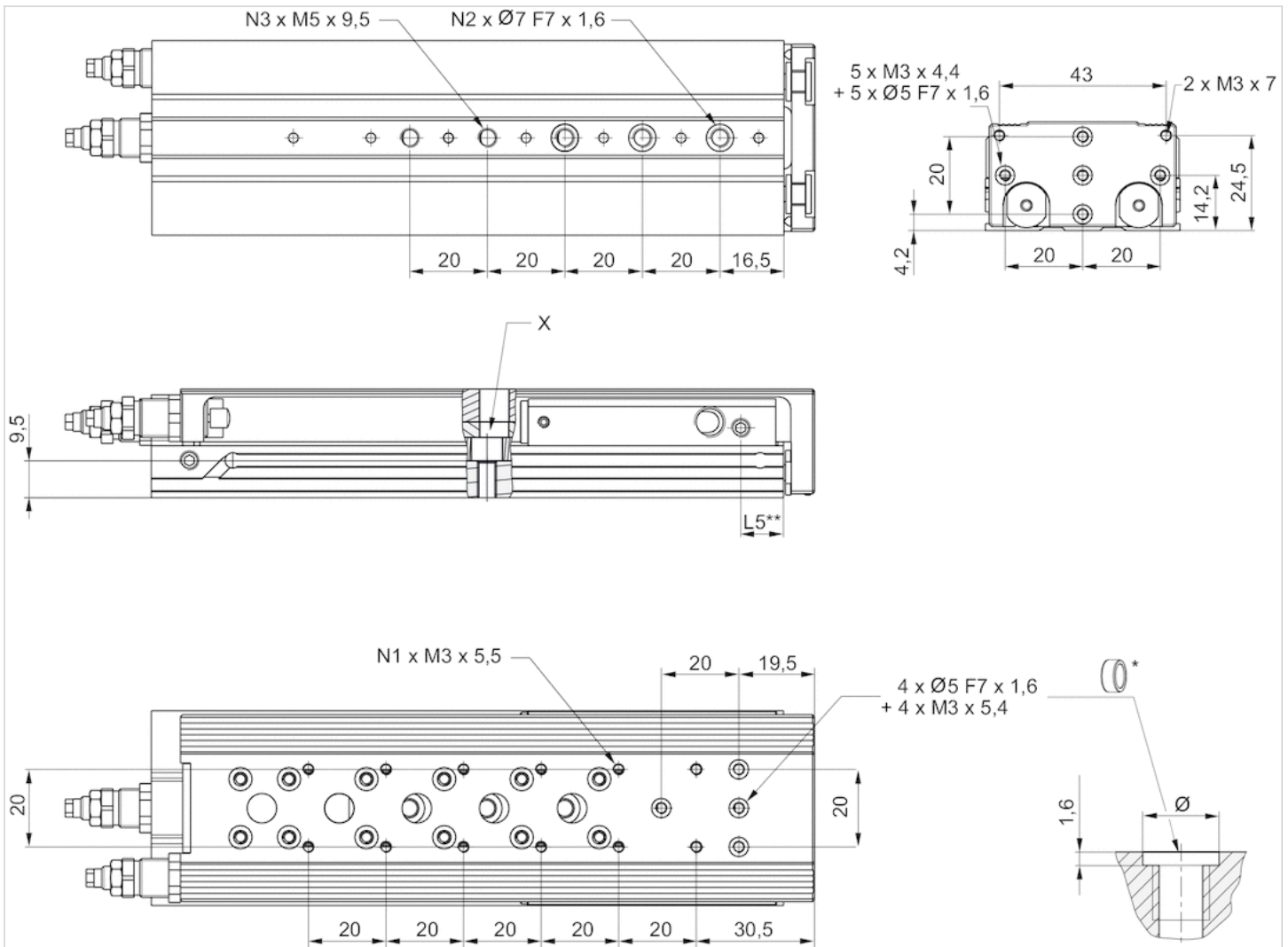

* = centering rings

** $\varnothing 8$ has a different reference plane.

Dimensions

Piston \varnothing	S	N1	N2	N3	L5	X
8 mm	10	4	2	2	11	-
8 mm	20	4	2	2	11	-
8 mm	30	4	2	2	11	-
8 mm	40	4	2	2	11	-
8 mm	50	4	3	3	11	1)
8 mm	80	8	3	5	11	-

S = stroke

1) Access to the through hole only after removal of the stroke limitation bolts

Dimensions

MSC-12

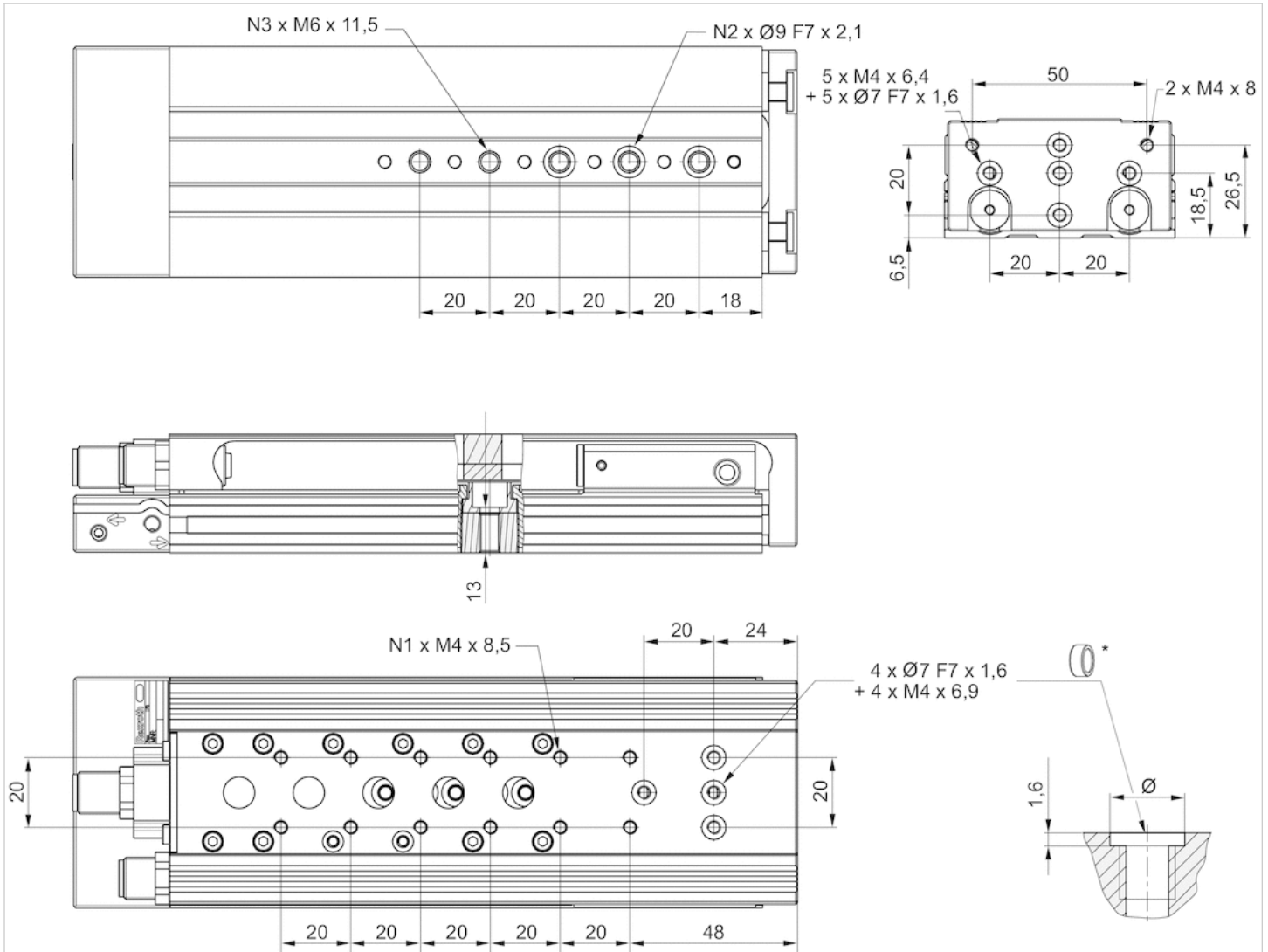

* = centering rings

Dimensions

Piston \varnothing	S	N1	N2	N3
12 mm	10	2	2	2
12 mm	20	2	2	2
12 mm	30	2	2	2
12 mm	40	2	2	2
12 mm	50	4	3	3
12 mm	80	6	3	5
12 mm	100	8	3	5

S = stroke

Dimensions

MSC-16

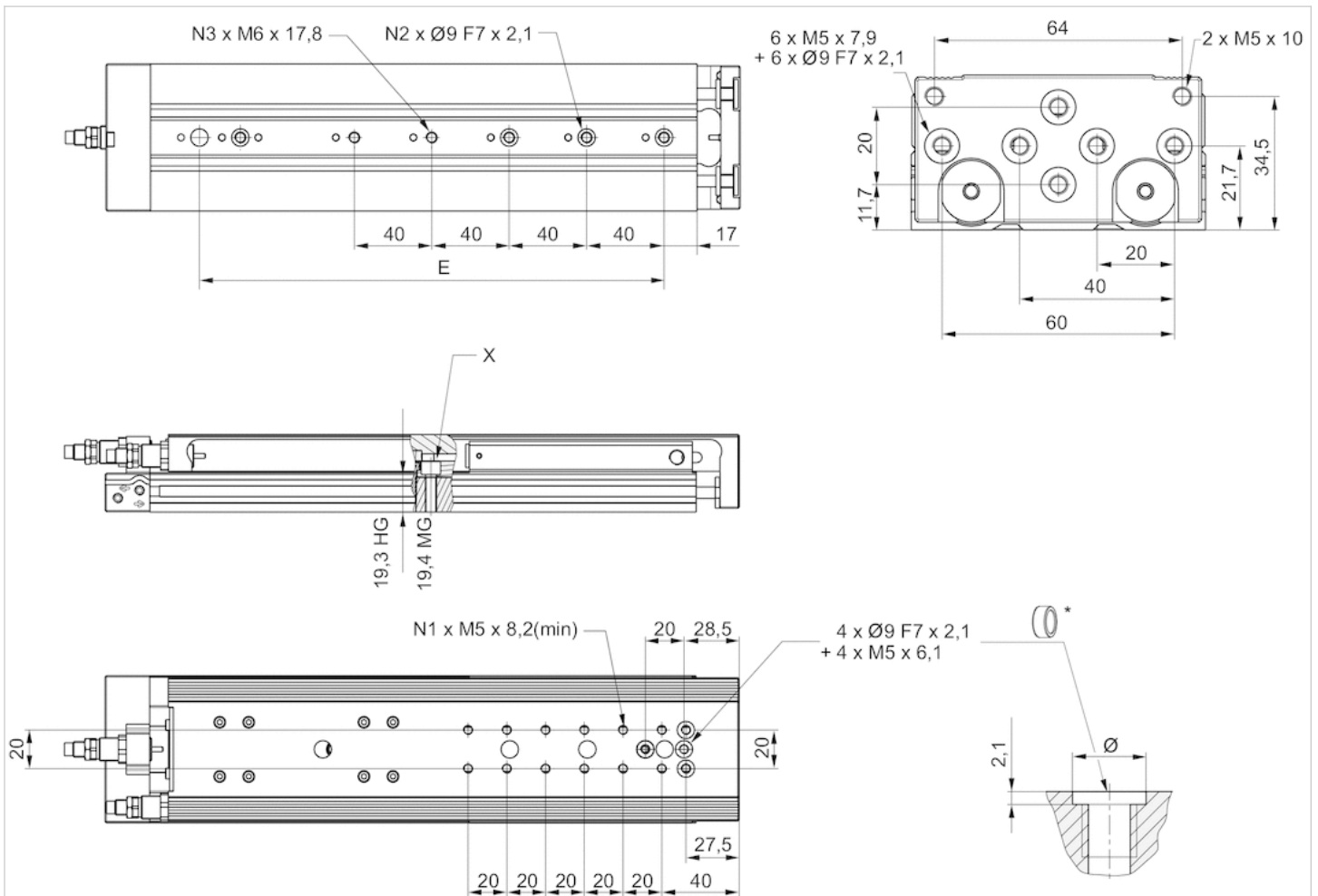

* = centering rings

Dimensions

Piston \varnothing	S	N1	N2	N3	X
16 mm	10	2	2	2	1)
16 mm	20	2	2	2	1)
16 mm	30	2	2	2	-
16 mm	40	4	2	2	-
16 mm	50	4	2	2	-
16 mm	80	6	3	3	-
16 mm	100	8	3	3	-

S = stroke

1) Access to the through hole only after removal of the stroke limitation bolts

Dimensions

MSC-20

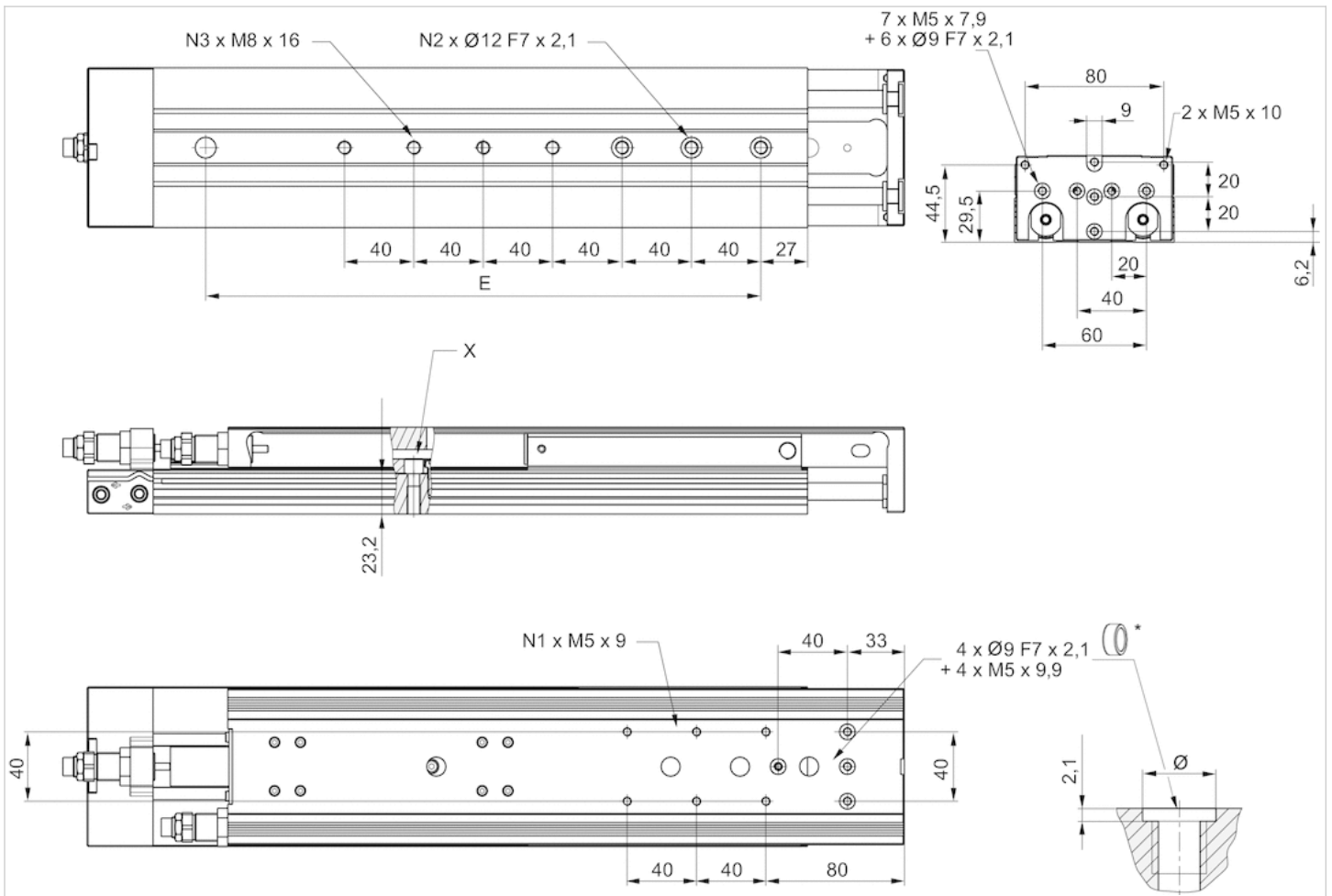

* = centering rings

Dimensions

Piston Ø	S	N1	N2	N3	X
20 mm	10	2	2	2	1)
20 mm	20	2	2	2	1)
20 mm	30	2	2	2	-
20 mm	40	2	2	2	-
20 mm	50	2	2	2	-
20 mm	80	4	3	3	-
20 mm	100	4	3	3	-

S = stroke

1) Access to the through hole only after removal of the stroke limitation bolts

Piston Ø	S	N1	N2	N3	X
25 mm	30	2	2	2	1)
25 mm	40	2	2	2	-
25 mm	50	4	2	2	-
25 mm	80	4	3	3	-
25 mm	100	4	3	3	-

S = stroke

1) Access to the through hole only after removal of the stroke limitation bolts

Weight [kg]

Part No.	Piston Ø	Stroke	Weight kg
R480640120	8 mm	10	0.37 kg
R480640121	8 mm	20	0.36 kg
R480640122	8 mm	30	0.35 kg
R480640123	8 mm	40	0.34 kg
R480640124	8 mm	50	0.41 kg
R480640125	8 mm	80	0.56 kg
R480640126	12 mm	10	0.62 kg
R480640127	12 mm	20	0.61 kg
R480640128	12 mm	30	0.6 kg
R480640129	12 mm	40	0.59 kg
R480640130	12 mm	50	0.67 kg
R480640131	12 mm	80	0.92 kg
R480640132	12 mm	100	0.99 kg
R480640133	16 mm	10	0.81 kg
R480640134	16 mm	20	0.79 kg
R480640135	16 mm	30	0.76 kg
R480640136	16 mm	40	0.82 kg
R480640137	16 mm	50	1.29 kg
R480640138	16 mm	80	1.37 kg
R480640139	16 mm	100	1.94 kg
R480640140	20 mm	10	1.36 kg
R480640141	20 mm	20	1.42 kg
R480640142	20 mm	30	1.38 kg
R480640143	20 mm	40	1.45 kg
R480640144	20 mm	50	1.61 kg
R480640145	20 mm	80	2.1 kg
R480640146	20 mm	100	2.23 kg
R480640147	25 mm	10	2.5 kg
R480640148	25 mm	20	2.46 kg
R480640149	25 mm	30	2.42 kg
R480640150	25 mm	40	2.38 kg
R480640151	25 mm	50	2.64 kg
R480640152	25 mm	80	3.29 kg
R480640153	25 mm	100	3.56 kg

Dimensions

Load capacity

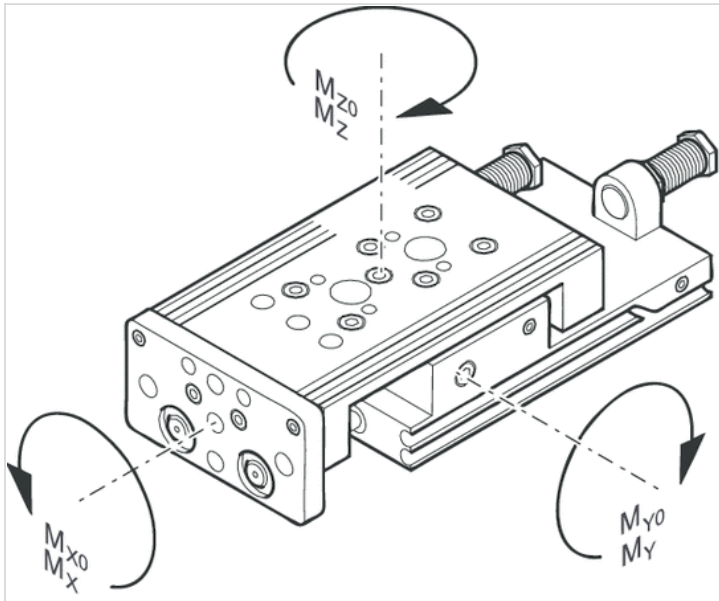

M = max. permissible torque

correction factor (a)

Piston Ø	Stroke	a [mm] 1)	d [mm] 2)	Mx0 Static moment M [Nm]
8 mm	10	69.5	12	5.8
8 mm	20	69.5	12	5.8
8 mm	30	69.5	12	5.8
8 mm	40	69.5	12	5.8
8 mm	50	83	12	5.8
8 mm	80	121	12	8
12 mm	10	77	15	13.8
12 mm	20	77	15	13.8
12 mm	30	77	15	13.8
12 mm	40	77	15	13.8
12 mm	50	81	15	13.8
12 mm	80	117	15	17.3
12 mm	100	137	15	17.3
16 mm	10	65	15	31.6
16 mm	20	65	15	31.6
16 mm	30	65	15	31.6
16 mm	40	75	15	31.6
16 mm	50	86	15	31.6
16 mm	80	123	15	45
16 mm	100	144	15	45
20 mm	10	75	20	31.6
20 mm	20	75	20	31.6
20 mm	30	75	20	31.6
20 mm	40	75	20	31.6

Piston Ø	Stroke	a [mm] 1)	d [mm] 2)	Mx0 Static moment M [Nm]
20 mm	50	92	20	31.6
20 mm	80	125	20	45
20 mm	100	143	20	45
25 mm	10	85	24	87
25 mm	20	85	24	87
25 mm	30	85	24	87
25 mm	40	85	24	87
25 mm	50	102	24	87
25 mm	80	134	24	110
25 mm	100	152	24	110

My0 Static moment M [Nm]	Mz0 Static moment M [Nm]	Mx Dynamic moment M [Nm]
5.9	5.9	1.1
5.9	5.9	1.1
5.9	5.9	1.1
5.9	5.9	1.1
5.9	5.9	1.3
14.6	14.6	1.3
6.45	6.45	3.5
6.45	6.45	3.5
6.45	6.45	3.5
6.45	6.45	3.5
6.45	6.45	3.5
15.6	15.6	5.2
15.6	15.6	5.2
11.95	11.95	6.5
11.95	11.95	6.5
11.95	11.95	6.5
11.95	11.95	6.5
11.95	11.95	7
27.3	27.3	8.7
27.3	27.3	8.7
11.95	11.95	9.6
11.95	11.95	9.6
11.95	11.95	9.6
11.95	11.95	9.6
11.95	11.95	10
27.3	27.3	11.7
27.3	27.3	11.7
24.5	24.5	22.9
24.5	24.5	22.9
24.5	24.5	22.9
24.5	24.5	22.9
24.5	24.5	15.3
62.5	62.5	18.8
62.5	62.5	18.8

My Dynamic moment M [Nm]	Mz Dynamic moment M [Nm]
1.7	1.7

My Dynamic moment M [Nm]	Mz Dynamic moment M [Nm]
1.7	1.7
1.7	1.7
1.7	1.7
1.7	1.7
3.7	3.7
1.6	1.6
1.6	1.6
1.6	1.6
1.6	1.6
1.6	1.6
3.5	3.5
3.5	3.5
3.2	3.2
3.2	3.2
3.2	3.2
3.2	3.2
3.2	3.2
6.3	6.3
6.3	6.3
4	4
4	4
4	4
4	4
4	4
8	8
8	8
6.6	6.6
6.6	6.6
6.6	6.6
6.6	6.6
6.6	6.6
14.5	14.6
14.5	14.6

Dimensions

correction factor (a, d)

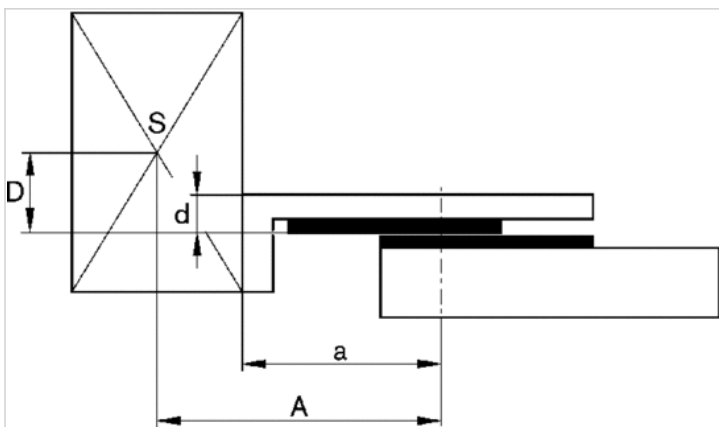

horizontal

stat.	$M_{B0} = F_G \cdot A + F \cdot D$
dyn.	$M_B = F_G \cdot A$

stat.	$M_{C0} = F_G \cdot B$
dyn.	$M_C = F_G \cdot B$

stat.	$M_{A0} = F \cdot B$
dyn.	$M_A = 0$

dyn.	$\frac{M_A}{M_1} + \frac{M_B}{M_2} + \frac{M_C}{M_3} \leq 1$
stat.	$\frac{M_{A0}}{M_{Z0}} + \frac{M_{B0}}{M_{Y0}} + \frac{M_{C0}}{M_{X0}} \leq 1$

$F = m \cdot a$
 $FG = m \cdot g$
 $a = 1250 \cdot V^2 / H$

- F = deceleration force [N]
- FG= force due to weight [N]
- m = load mass [kg]
- a = deceleration [m/s²]
- g = gravitational acceleration 9,81 [m/s²]
- V = velocity [m/s]
- H = stroke length of shock absorber [mm]

vertical

stat.	$M_{B0} = (F_G + F) \cdot D$
dyn.	$M_B = F_G \cdot D$

stat.	$M_{A0} = (F_G + F) \cdot B$
dyn.	$M_A = F_G \cdot B$

dyn.	$\frac{M_A}{M_1} + \frac{M_B}{M_2} \leq 1$
stat.	$\frac{M_{A0}}{M_{Z0}} + \frac{M_{B0}}{M_{Y0}} \leq 1$

$F = m \cdot a$
 $FG = m \cdot g$

$$a = 1250 \cdot V^2 / H$$

F = deceleration force [N]

FG = force due to weight [N]

m = load mass [kg]

a = deceleration [m/s²]

g = gravitational acceleration 9,81 [m/s²]

V = velocity [m/s]

H = stroke length of shock absorber [mm]

Diagrams

Maximum moving mass

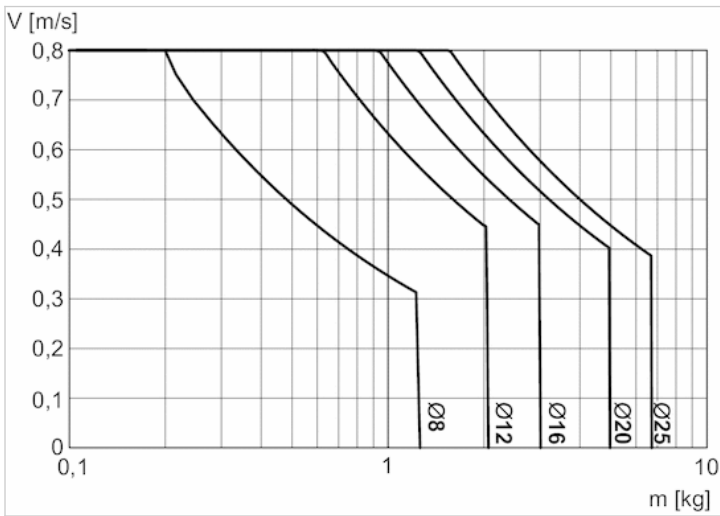

V = velocity [m/s]

m = mass

Correction factor for required speed: retracting and extending, horizontal

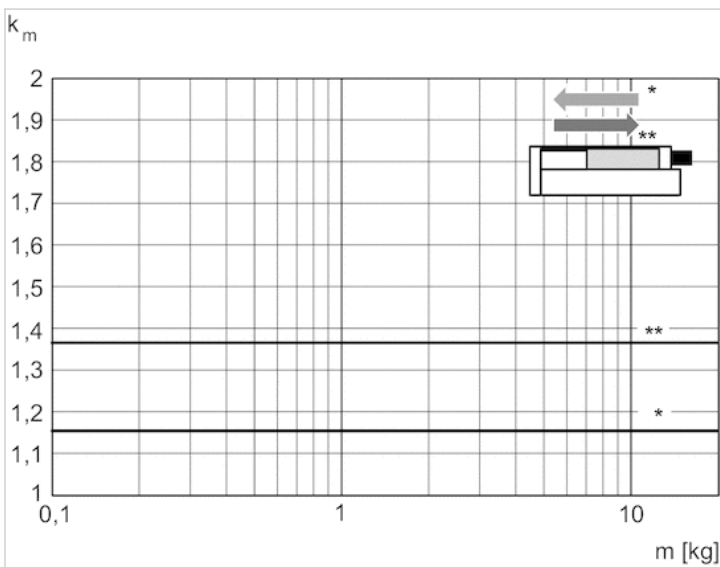

* retracting

** extracting

$$V = s / 1000 \cdot t \cdot k_m$$

V = velocity [m/s]

S = stroke

Correction factor for required speed: extending, vertical, upwards

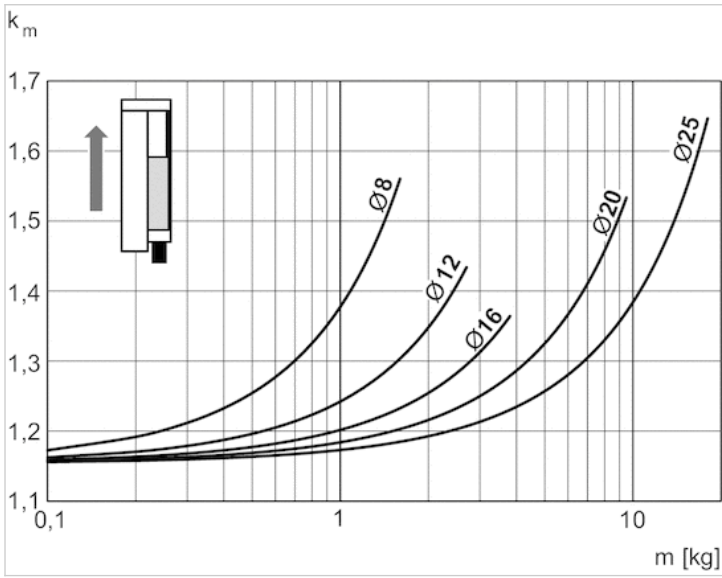

$V = s/1000 \cdot t \cdot k_m$
 $V = \text{velocity [m/s]}$
 $S = \text{stroke [mm]}$
 $t = \text{time [s] for one stroke}$
 $m = \text{mass}$

Correction factor for required speed: retracting, vertical, upwards

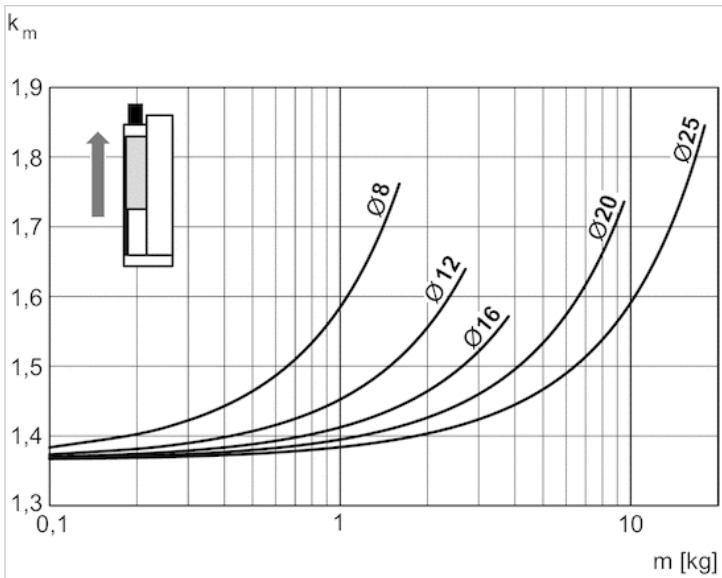

$V = s/1000 \cdot t \cdot k_m$
 $V = \text{velocity [m/s]}$
 $S = \text{stroke [mm]}$
 $t = \text{time [s] for one stroke}$
 $m = \text{mass}$

Correction factor for required speed: retracting, vertical, downwards

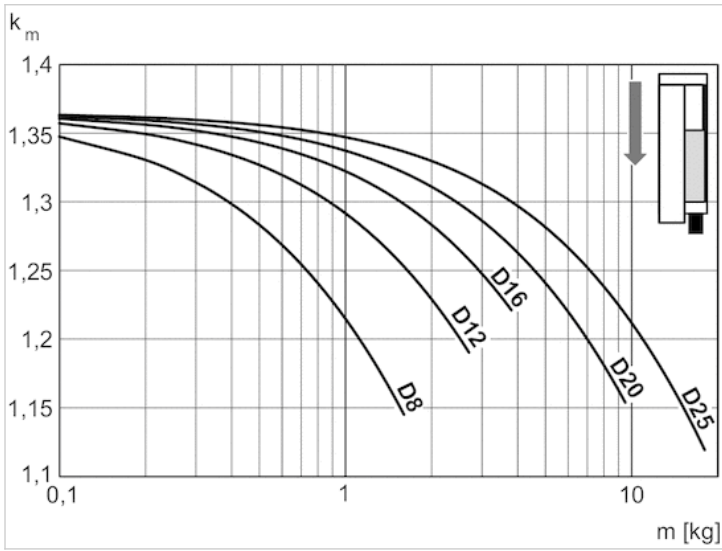

$V = s/1000 \cdot t \cdot k_m$
 V = velocity [m/s]
 S = stroke [mm]
 t = time [s] for one stroke
 m = mass

Correction factor for required speed: extending, vertical, downwards

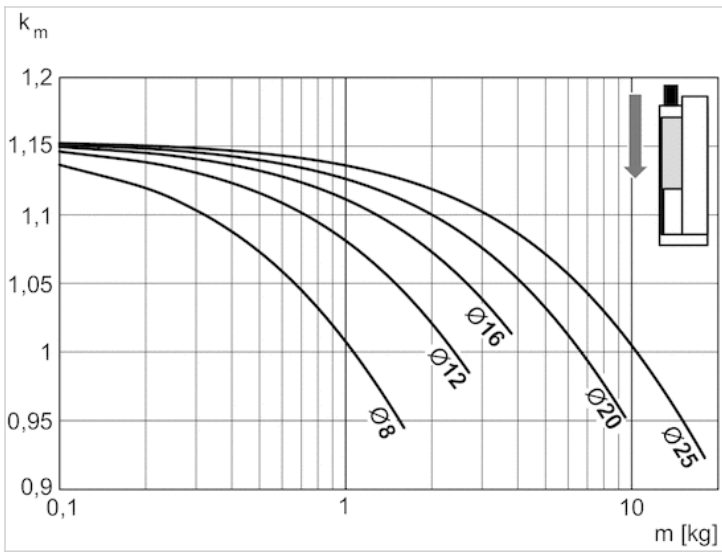

$V = s/1000 \cdot t \cdot k_m$
 V = velocity [m/s]
 S = stroke [mm]
 t = time [s] for one stroke
 m = mass

Extracting speed max.

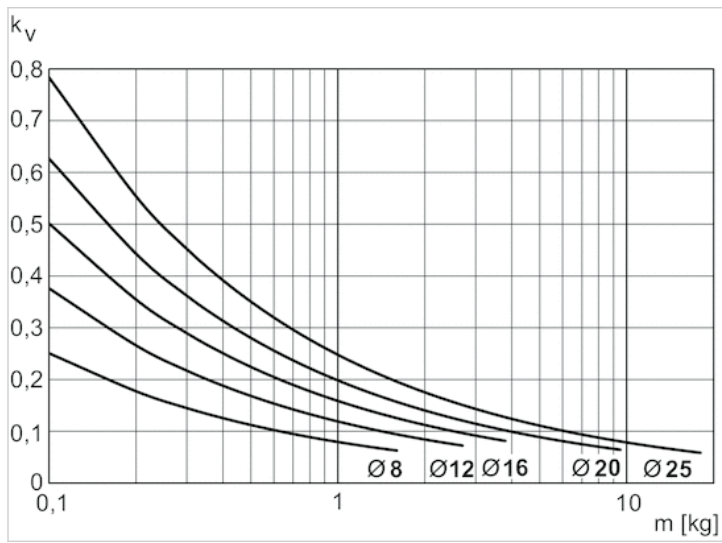

$V = \sqrt{s \cdot kv}$
 V = velocity [m/s]
 S = stroke [mm]
 m = mass

Accessories overview

Overview drawing

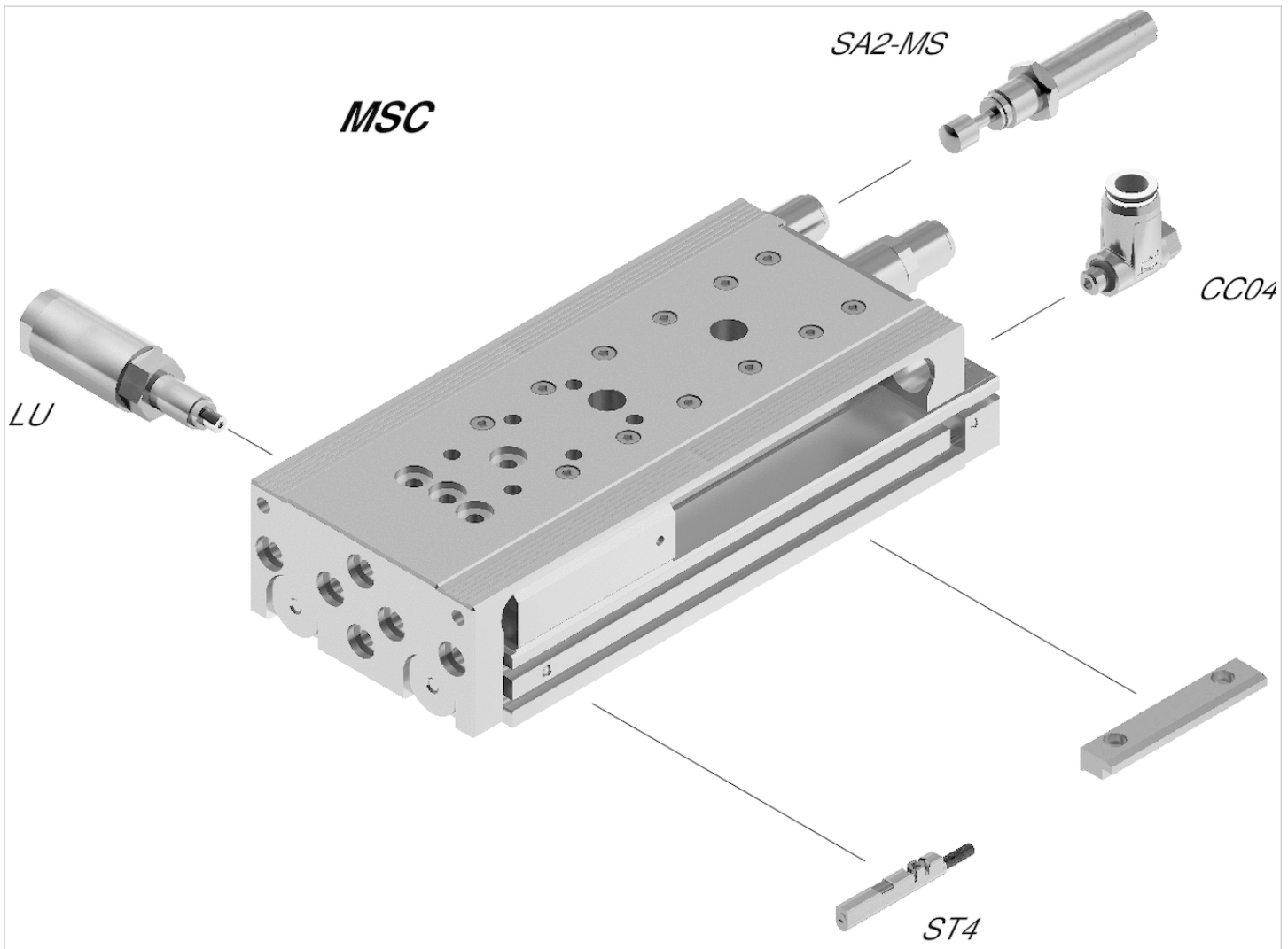

NOTE:

This overview drawing is only for orientation to indicate where the various accessory parts can be fastened to the cylinder. The illustration has been simplified for this purpose. It is thus not possible to derive the dimensions from this overview.

Mini slide, Series MSC-MG-EM

- Scope of delivery: incl. centering rings
- Ø 8-25 mm
- double-acting
- with magnetic piston
- Cushioning Elastic with metal end stop
- Easy2Combine capable
- with double piston
- With integrated ball rail system



Working pressure min./max.	3 ... 10 bar
Ambient temperature min./max.	0 ... 60 °C
Medium	Compressed air
Max. particle size	5 µm
Oil content of compressed air	0 ... 1 mg/m ³
Pressure for determining piston forces	6.3 bar
Repetitive precision	0,02 mm
Weight	See table below

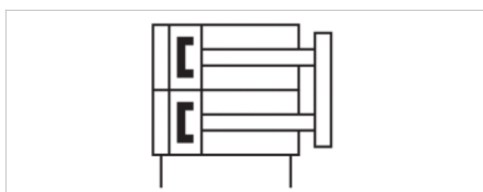

Technical data

Piston Ø	8 mm	12 mm	16 mm	20 mm	25 mm
Stroke 10	R480643754	R480643760	R480643767	R480643774	R480643781
20	R480643755	R480643761	R480643768	R480643775	R480643782
30	R480643756	R480643762	R480643769	R480643776	R480643783
40	R480643757	R480643763	R480643770	R480643777	R480643784
50	R480643758	R480643764	R480643771	R480643778	R480643785
80	R480643759	R480643765	R480643772	R480643779	R480643786
100	-	R480643766	R480643773	R480643780	R480643787

Technical data

Piston Ø 2x	8 mm	12 mm	16 mm	20 mm	25 mm
Retracting piston force, theoretical	48 N	107 N	218 N	297 N	520 N
Extracting piston force, theoretical	63 N	143 N	253 N	396 N	619 N
Speed max.	0.8 m/s	0.8 m/s	0.8 m/s	0.8 m/s	0.8 m/s
Cushioning length	0.65 mm	1.9 mm	1.9 mm	3.05 mm	2.5 mm

Piston Ø 2x	8 mm	12 mm	16 mm	20 mm	25 mm
Cushioning energy	0.03 J	0.06 J	0.12 J	0.3 J	0.4 J

Technical information

The pressure dew point must be at least 15 °C under ambient and medium temperature and may not exceed 3 °C .

The oil content of compressed air must remain constant during the life cycle.

Use only the approved oils from AVENTICS. Further information can be found in the “Technical information” document (available in the MediaCentre).

Repetitive precision after 100 consecutive strokes: 0,02 mm

Base with air connections at the back and sides

Intermediate strokes can be configured.

Scope of delivery: incl. centering rings

R1 = stroke setting range for forward stroke

R2 = stroke setting range for return stroke

Ø 8 has a different reference plane.

Technical information

Material	
Housing	Aluminum, anodized
Piston rod	Stainless steel
Front plate	Aluminum, anodized
Seal	Polyurethane
Ball rail table	Aluminum, anodized
Guide rail	Steel, hardened
Centering rings	Stainless steel

Dimensions

Dimensions

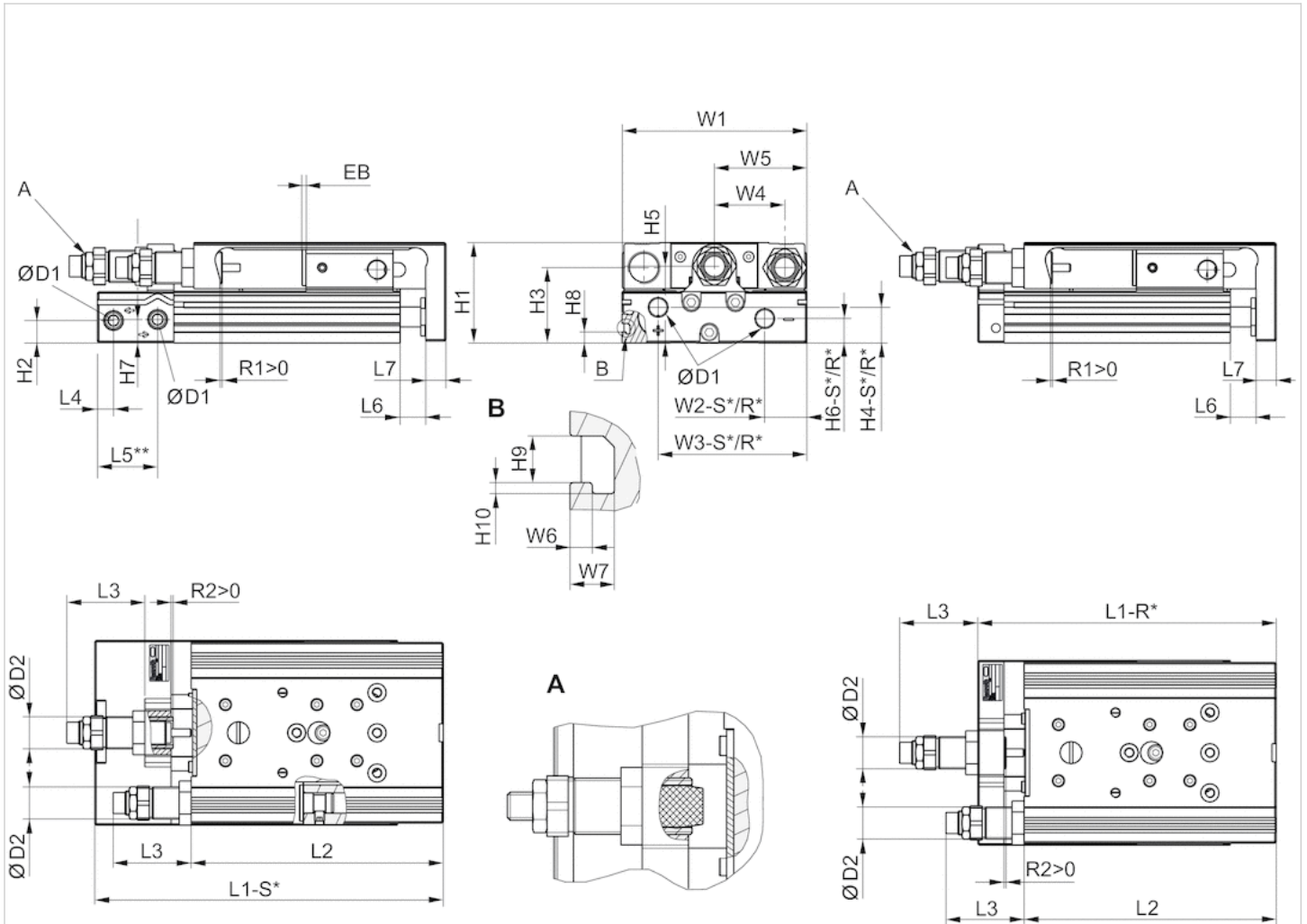

R*: base with air connections only at the back
 S*: base with air connections at the back and sides
 ** Ø 8 has a different reference plane.

Dimensions

Piston Ø	Ø D1	Ø D2	H1	H2	H3	H4-R	H4-S	H5	H6-R	H6-S	H7	H8	H9	H10	L3 max.	L4
8 mm	M5	M10x1	28	9.6	20.5	-	7.5	19.5	-	5.5	18	-	-	-	27.8	9.8
12 mm	M5	M12x1	34	5.7	25	11.2	11.2	24.5	5.7	5.7	8.3	-	-	-	31.8	7.2
16 mm	M5	M12x1	40	7.2	29	12.2	12.2	31	7.7	7.7	11.2	-	-	-	30	6.5
20 mm	G 1/8	M16x1,5	50	11.2	37.5	17.3	17.3	38.2	11.7	12.2	11.7	5.5	4.2	1	43.7	8
25 mm	G 1/8	M18x1,5	60	14.2	44	15.5	22.9	46.5	13.2	21.7	16.2	6.9	5.2	1.5	41.9	9

Piston Ø	L5 2)	L6	L7	W1	W2-R	W2-S	W3-R	W3-S	W4	W5	W6	W7
8 mm	-	1.9	6	50.2	-	19.3	-	30.5	18	W1/2	-	-
12 mm	22.5	2	8	66	28.8	28.8	53	53	24.5	W1/2	-	-
16 mm	17.7	2	10	76	31	31	60.5	60.5	30	W1/2	-	-
20 mm	30	2.1	10	92	10	21	74	74	35	W1/2	2	4
25 mm	31	2.1	12	112	11	14	92	92	44	W1/2	2.5	4.8

Stroke-dependent dimensions

Piston Ø	S=10 EB	S=20 EB	S=30 EB	S=40 EB	S=50 EB	S=80 EB	S=100 EB	S=10 L1-R
8 mm	32	22	12	2	2	2	–	–
12 mm	32	22	12	2	2	2	2	111
16 mm	22	12	2	2	2	2	2	103.5
20 mm	22	12	2	2	2	2	2	115
25 mm	32	22	12	2	2	2	2	138.5

S=20 L1-R	S=30 L1-R	S=40 L1-R	S=50 L1-R	S=80 L1-R	S=100 L1-R	S=10 L1-S	S=20 L1-S
–	–	–	–	–	–	101.7	101.7
111	111	111	126	172	192	127.9	127.9
103.5	103.5	113.5	128.5	174.5	194.5	114.4	114.4
115	115	125	140	185	205	139.9	139.9
138.5	138.5	138.5	151.5	197.5	217.5	162.2	162.2

S=30 L1-S	S=40 L1-S	S=50 L1-S	S=80 L1-S	S=100 L1-S	S=10 L2	S=20 L2	S=30 L2	S=40 L2
101.7	101.7	121.7	171.7	–	93.5	93.5	93.5	93.5
127.9	127.9	142.9	188.9	208.9	98.8	98.8	98.8	98.8
114.4	124.4	139.4	185.4	205.4	90.4	90.4	90.4	100.4
139.9	149.9	164.9	209.9	229.9	100.5	100.5	100.5	110.5
162.2	162.2	175.2	221.2	241.2	121.5	121.5	121.5	121.5

S=50 L2	S=80 L2	S=100 L2	S=10 R1 max.	S=20 R1 max.	S=30 R1 max.	S=40 R1 max.
113.5	163.5	–	4.2	4.2	4.2	4.2
113.8	159.8	179.8	5.7	5.7	5.7	5.7
115.4	161.4	181.4	8.7	8.7	8.7	8.7
125.5	170.5	190.5	12.4	12.4	12.4	12.4
134.5	180.5	200.5	11.5	11.5	11.5	11.5

S=50 R1 max.	S=80 R1 max.	S=100 R1 max.	S=10 R2 max.	S=20 R2 max.	S=30 R2 max.
4.2	4.2	–	4.1	4.1	4.1
5.7	5.7	5.7	2	2	2
8.7	8.7	8.7	1.5	1.5	1.5
12.4	12.4	12.4	1.5	1.5	1.5
10.5	11.5	11.5	7.5	7.5	7.5

S=40 R2 max.	S=50 R2 max.	S=80 R2 max.	S=100 R2 max.
4.1	4.1	4.1	–
2	10	12	12
1.5	6	7	5.7
11.5	9.5	14	14
7.5	3.3	7.5	9.2

Dimensions

MSC-08

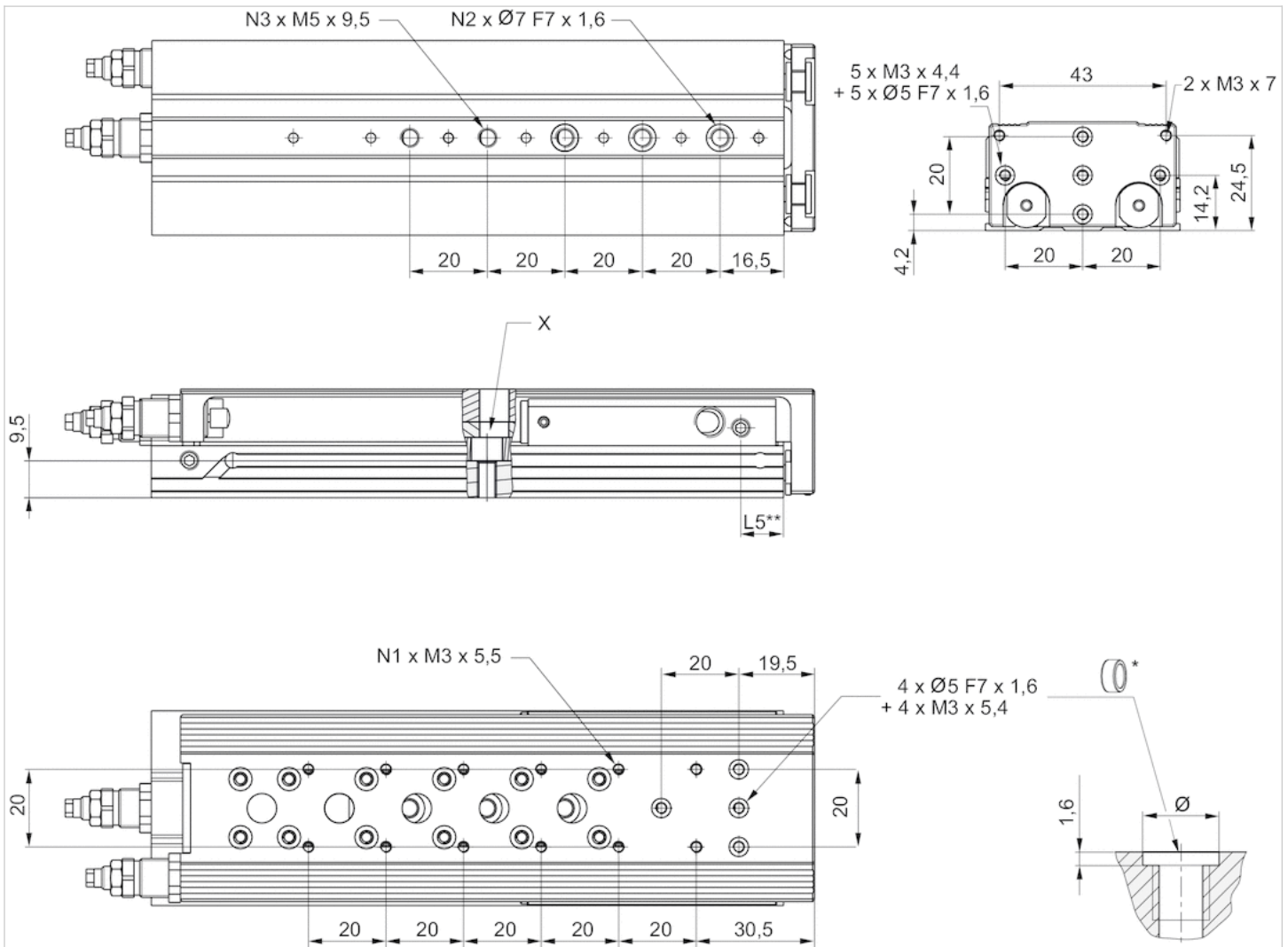

* = centering rings

** $\varnothing 8$ has a different reference plane.

Dimensions

Piston \varnothing	S	N1	N2	N3	L5	X
8 mm	10	4	2	2	11	-
8 mm	20	4	2	2	11	-
8 mm	30	4	2	2	11	-
8 mm	40	4	2	2	11	-
8 mm	50	4	3	3	11	1)
8 mm	80	8	3	5	11	-

S = stroke

1) Access to the through hole only after removal of the stroke limitation bolts

Dimensions

MSC-12

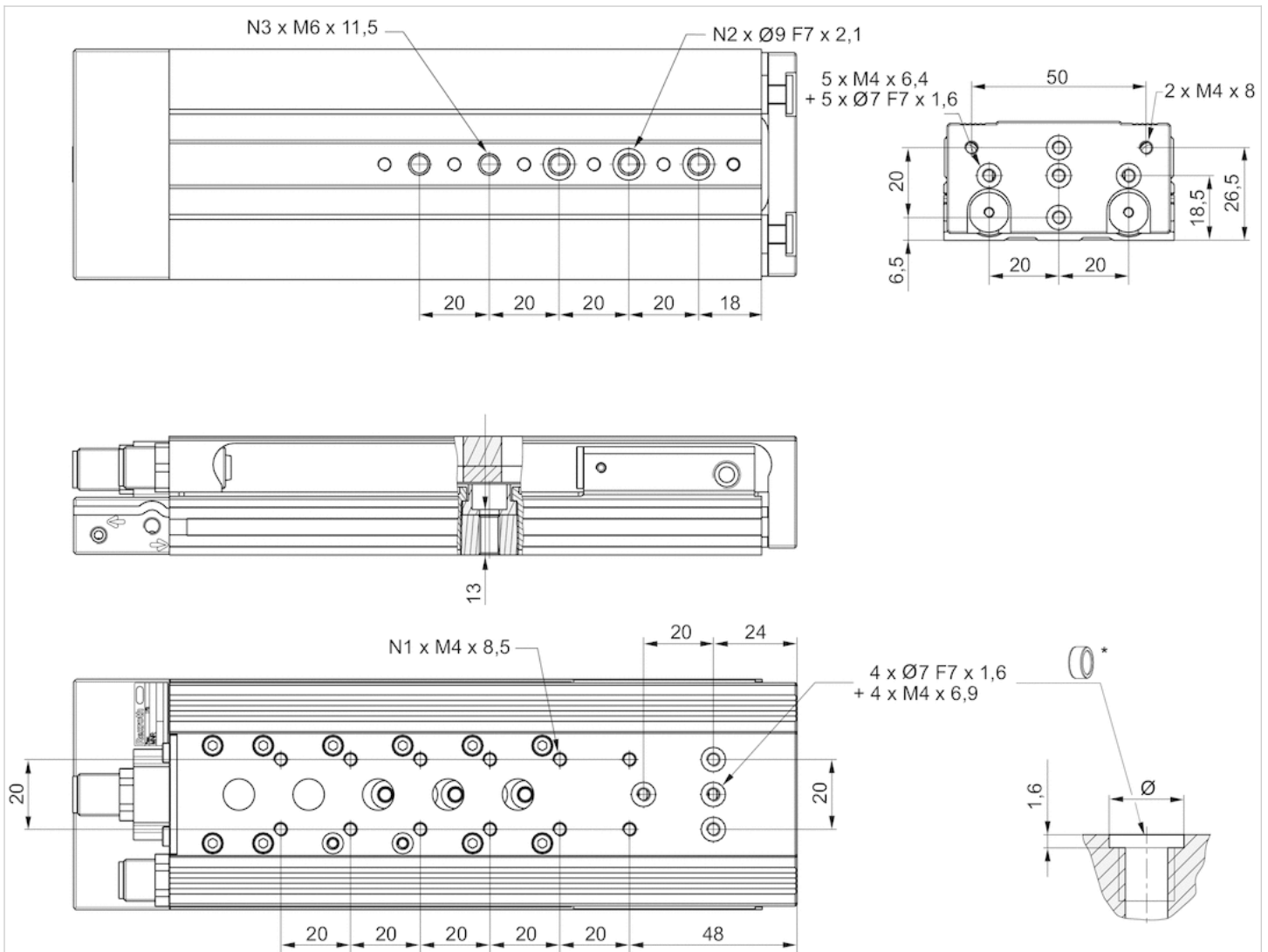

* = centering rings

Dimensions

Piston Ø	S	N1	N2	N3
12 mm	10	2	2	2
12 mm	20	2	2	2
12 mm	30	2	2	2
12 mm	40	2	2	2
12 mm	50	4	3	3
12 mm	80	6	3	5
12 mm	100	8	3	5

S = stroke

Dimensions

MSC-16

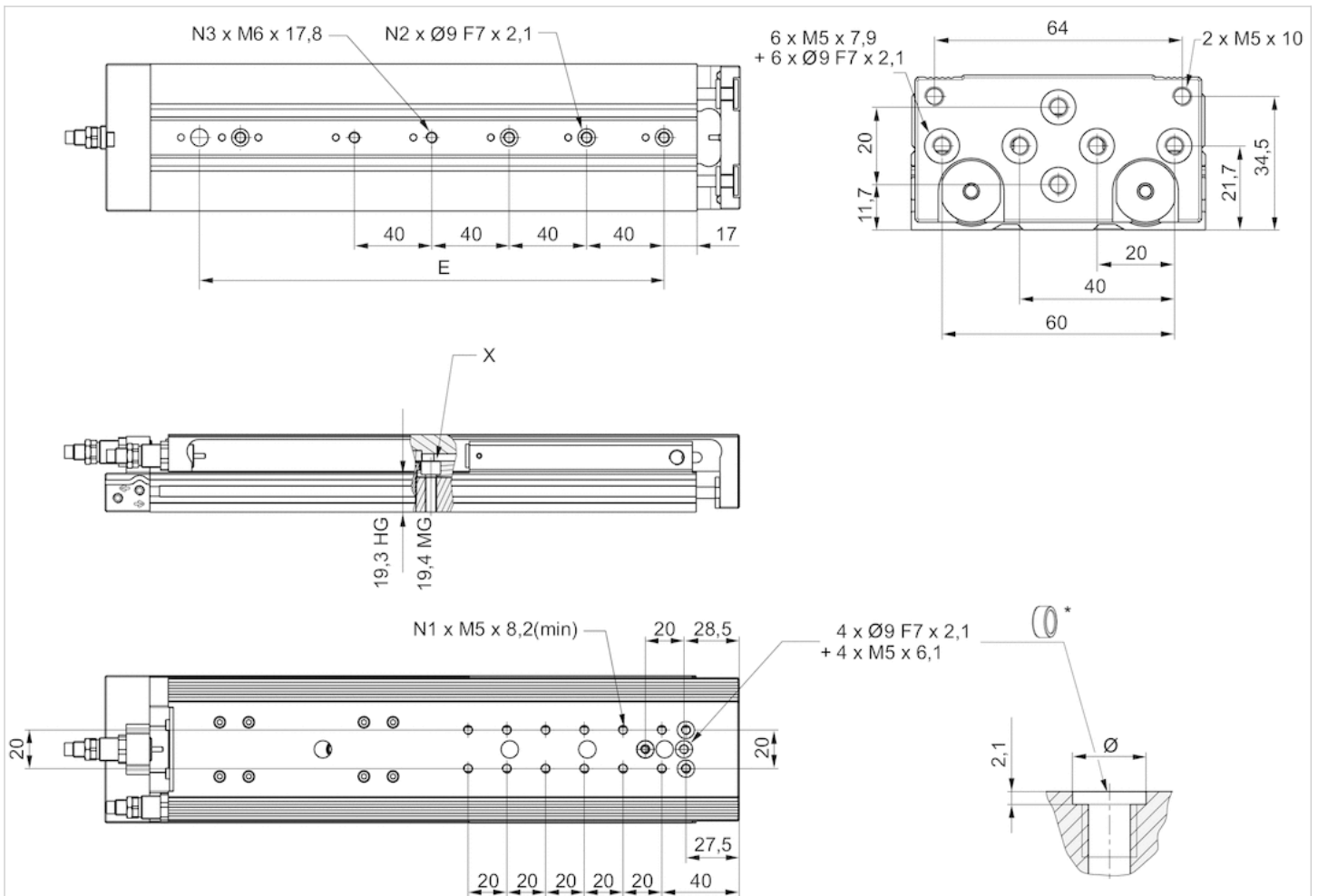

* = centering rings

Dimensions

Piston \varnothing	S	N1	N2	N3	X
16 mm	10	2	2	2	1)
16 mm	20	2	2	2	1)
16 mm	30	2	2	2	-
16 mm	40	4	2	2	-
16 mm	50	4	2	2	-
16 mm	80	6	3	3	-
16 mm	100	8	3	3	-

S = stroke

1) Access to the through hole only after removal of the stroke limitation bolts

Dimensions

MSC-20

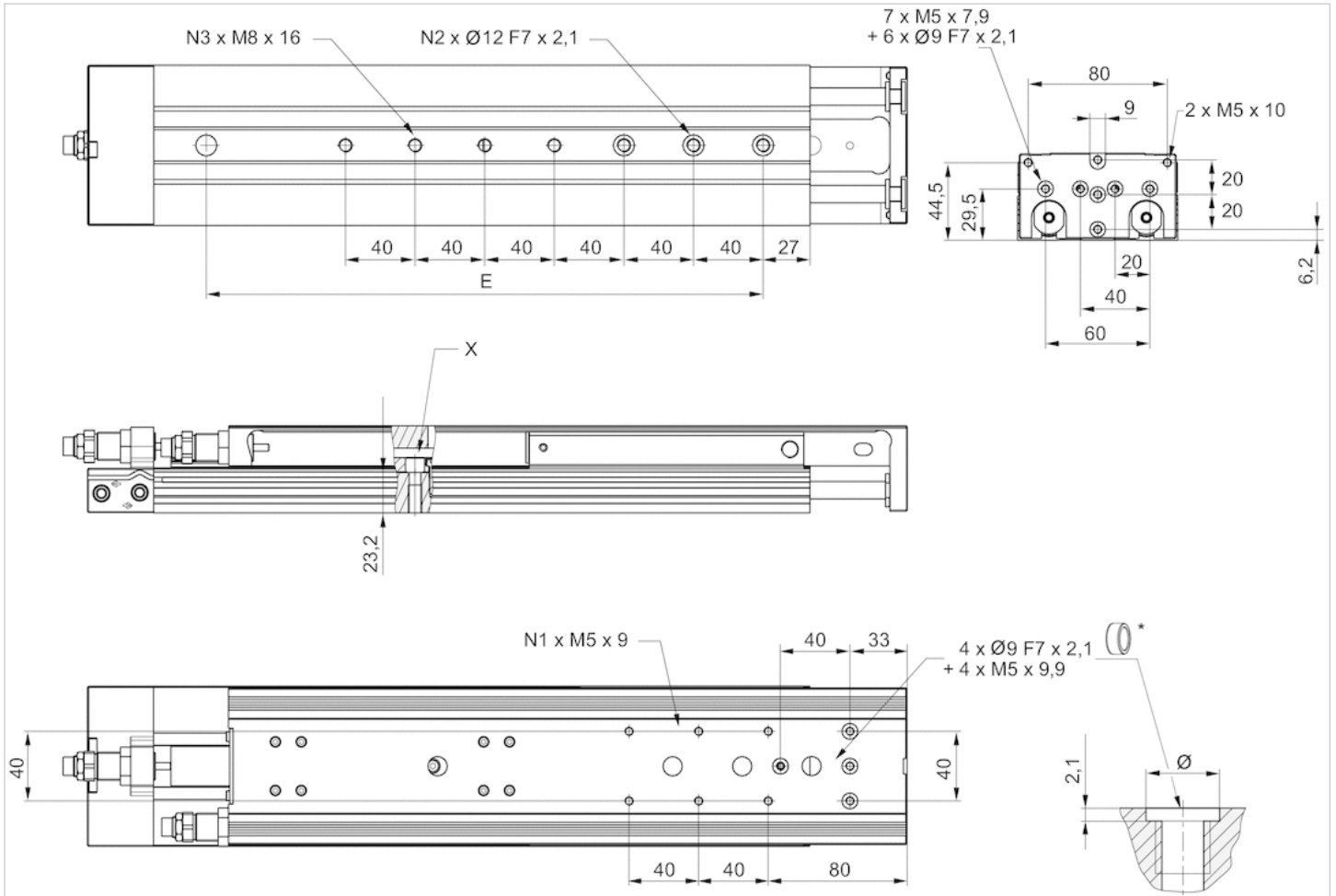

* = centering rings

Dimensions

Piston Ø	S	N1	N2	N3	X
20 mm	10	2	2	2	1)
20 mm	20	2	2	2	1)
20 mm	30	2	2	2	-
20 mm	40	2	2	2	-
20 mm	50	2	2	2	-
20 mm	80	4	3	3	-
20 mm	100	4	3	3	-

S = stroke

1) Access to the through hole only after removal of the stroke limitation bolts

Dimensions

MSC-25

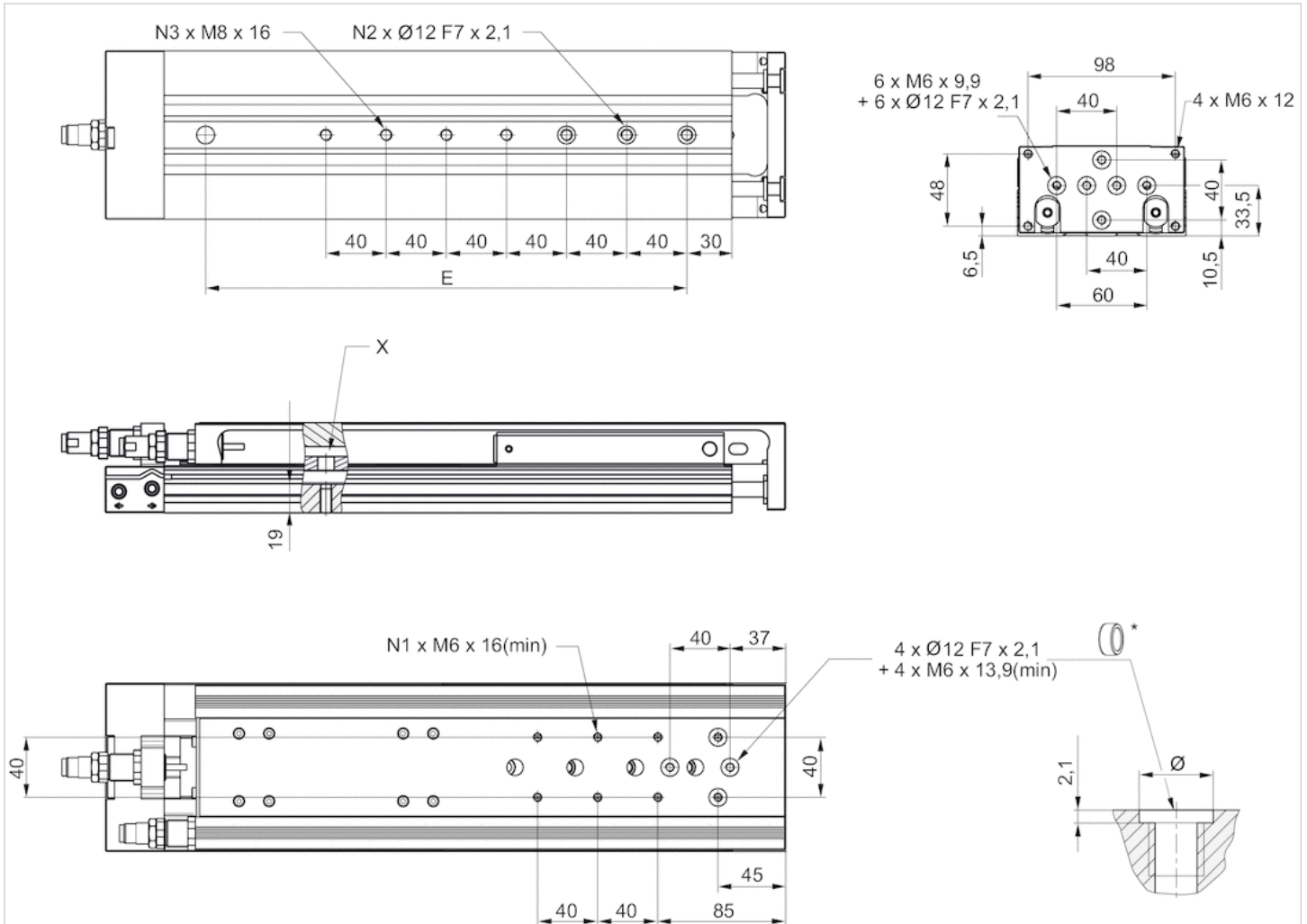

* = centering rings

Dimensions

Piston \varnothing	S	N1	N2	N3	X
25 mm	10	2	2	2	1)
25 mm	20	2	2	2	1)
25 mm	30	2	2	2	1)
25 mm	40	2	2	2	-
25 mm	50	4	2	2	-
25 mm	80	4	3	3	-
25 mm	100	4	3	3	-

S = stroke

1) Access to the through hole only after removal of the stroke limitation bolts

Weight of moving parts [kg]

Piston Ø	S=10	S=20	S=30	S=40	S=50	S=80	S=100	S=125	S=150	S=200
8 mm	0.165	0.165	0.165	0.165	0.195	0.265	–	–	–	–
12 mm	0.28	0.28	0.28	0.28	0.315	0.403	0.46	–	–	–
16 mm	0.375	0.375	0.375	0.4	0.45	0.615	0.65	0.725	0.765	–
20 mm	0.655	0.655	0.655	0.69	0.765	0.985	1.035	1.2	1.29	1.54
25 mm	1.1	1.1	1.1	1.1	1.225	1.45	1.625	1.885	2.085	2.445

Weight [kg]

Piston Ø	Stroke	Weight kg
8 mm	10	0.37 kg
8 mm	20	0.36 kg
8 mm	30	0.35 kg
8 mm	40	0.34 kg
8 mm	50	0.41 kg
8 mm	80	0.56 kg
12 mm	10	0.62 kg
12 mm	20	0.61 kg
12 mm	30	0.56 kg
12 mm	40	0.59 kg
12 mm	50	0.67 kg
12 mm	80	0.92 kg
12 mm	100	0.99 kg
16 mm	10	0.81 kg
16 mm	20	0.79 kg
16 mm	30	0.76 kg
16 mm	-	0.82 kg
16 mm	50	1.29 kg
16 mm	80	1.37 kg
16 mm	100	1.94 kg
20 mm	10	1.36 kg
20 mm	20	1.42 kg
20 mm	30	1.38 kg
20 mm	40	1.45 kg
20 mm	50	1.61 kg
20 mm	80	2.1 kg
20 mm	100	2.23 kg
25 mm	10	2.32 kg
25 mm	20	2.46 kg
25 mm	30	2.22 kg
25 mm	40	2.38 kg
25 mm	50	2.64 kg
25 mm	80	3.29 kg
25 mm	-	3.56 kg

Dimensions

Load capacity

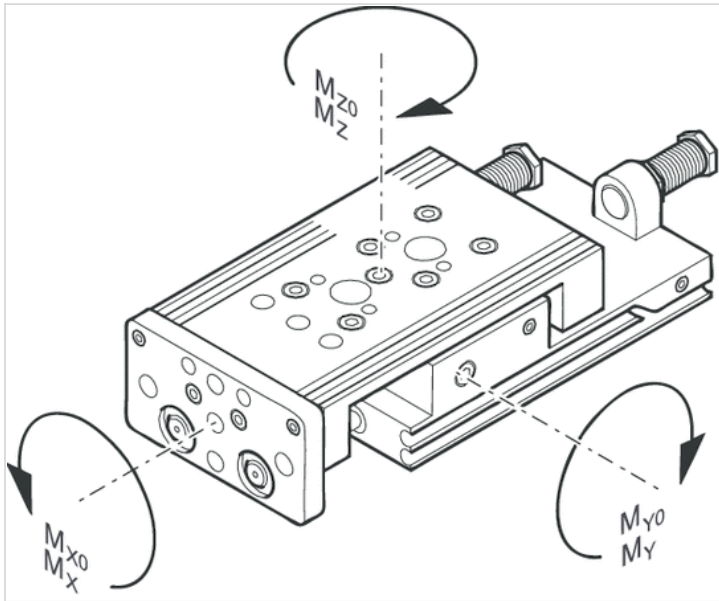

M = max. permissible torque

correction factor (a)

Piston Ø	Stroke	a [mm] 1)	d [mm] 2)	Mx0 Static moment M [Nm]
8 mm	10	69.5	12	5.8
8 mm	20	69.5	12	5.8
8 mm	30	69.5	12	5.8
8 mm	40	69.5	12	5.8
8 mm	50	83	12	5.8
8 mm	80	121	12	8
12 mm	10	77	15	13.8
12 mm	20	77	15	13.8
12 mm	30	77	15	13.8
12 mm	40	77	15	13.8
12 mm	50	81	15	13.8
12 mm	80	117	15	17.3
12 mm	100	137	15	17.3
16 mm	10	65	15	31.6
16 mm	20	65	15	31.6
16 mm	30	65	15	31.6
16 mm	-	40	75	15
16 mm	50	86	15	31.6
16 mm	80	123	15	45
16 mm	100	144	15	45
20 mm	10	75	20	31.6
20 mm	20	75	20	31.6
20 mm	30	75	20	31.6
20 mm	40	75	20	31.6

Piston Ø	Stroke	a [mm] 1)	d [mm] 2)	Mx0 Static moment M [Nm]
20 mm	50	92	20	31.6
20 mm	80	125	20	45
20 mm	100	143	20	45
25 mm	10	85	24	87
25 mm	20	85	24	87
25 mm	30	85	24	87
25 mm	40	85	24	87
25 mm	50	102	24	87
25 mm	80	134	24	110
25 mm	100	152	24	110

My0 Static moment M [Nm]	Mz0 Static moment M [Nm]	Mx Dynamic moment M [Nm]
5.9	5.9	1.1
5.9	5.9	1.1
5.9	5.9	1.1
5.9	5.9	1.1
5.9	5.9	1.3
14.6	14.6	1.3
6.45	6.45	3.5
6.45	6.45	3.5
6.45	6.45	3.5
6.45	6.45	3.5
6.45	6.45	3.5
15.6	15.6	5.2
15.6	15.6	5.2
11.95	11.95	6.5
11.95	11.95	6.5
11.95	11.95	6.5
31.6	11.95	11.95
11.95	11.95	7
27.3	27.3	8.7
27.3	27.3	8.7
11.95	11.95	9.6
11.95	11.95	9.6
11.95	11.95	9.6
11.95	11.95	9.6
11.95	11.95	10
27.3	27.3	11.7
27.3	27.3	11.7
24.5	24.5	22.9
24.5	24.5	22.9
24.5	24.5	22.9
24.5	24.5	22.9
24.5	24.5	15.3
62.5	62.5	18.8
62.5	62.5	18.8

My Dynamic moment M [Nm]	Mz Dynamic moment M [Nm]
1.7	1.7

My Dynamic moment M [Nm]	Mz Dynamic moment M [Nm]
1.7	1.7
1.7	1.7
1.7	1.7
1.7	1.7
3.7	3.7
1.6	1.6
1.6	1.6
1.6	1.6
1.6	1.6
1.6	1.6
3.5	3.5
3.5	3.5
3.2	3.2
3.2	3.2
3.2	3.2
6.5	3.2
3.2	3.2
6.3	6.3
6.3	6.3
4	4
4	4
4	4
4	4
4	4
8	8
8	8
6.6	6.6
6.6	6.6
6.6	6.6
6.6	6.6
6.6	6.6
14.5	14.6
14.5	14.6

Dimensions

correction factor (a, d)

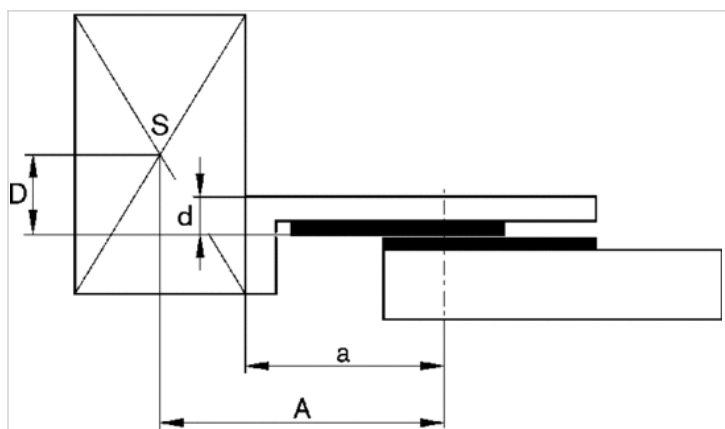

horizontal

stat.	$M_{B0} = F_G \cdot A + F \cdot D$
dyn.	$M_B = F_G \cdot A$

stat.	$M_{C0} = F_G \cdot B$
dyn.	$M_C = F_G \cdot B$

stat.	$M_{A0} = F \cdot B$
dyn.	$M_A = 0$

dyn.	$\frac{M_A}{M_1} + \frac{M_B}{M_2} + \frac{M_C}{M_3} \leq 1$
stat.	$\frac{M_{A0}}{M_{Z0}} + \frac{M_{B0}}{M_{Y0}} + \frac{M_{C0}}{M_{X0}} \leq 1$

$F = m \cdot a$
 $FG = m \cdot g$
 $a = 1250 \cdot V^2 / H$

- F = deceleration force [N]
- FG = force due to weight [N]
- m = load mass [kg]
- a = deceleration [m/s²]
- g = gravitational acceleration 9,81 [m/s²]
- V = velocity [m/s]
- H = stroke length of shock absorber [mm]

vertical

stat.	$M_{B0} = (F_G + F) \cdot D$
dyn.	$M_B = F_G \cdot D$

stat.	$M_{A0} = (F_G + F) \cdot B$
dyn.	$M_A = F_G \cdot B$

dyn.	$\frac{M_A}{M_1} + \frac{M_B}{M_2} \leq 1$
stat.	$\frac{M_{A0}}{M_{Z0}} + \frac{M_{B0}}{M_{Y0}} \leq 1$

$F = m \cdot a$
 $FG = m \cdot g$

$$a = 1250 \cdot V^2 / H$$

F = deceleration force [N]

FG = force due to weight [N]

m = load mass [kg]

a = deceleration [m/s²]

g = gravitational acceleration 9,81 [m/s²]

V = velocity [m/s]

H = stroke length of shock absorber [mm]

Diagrams

Maximum moving mass

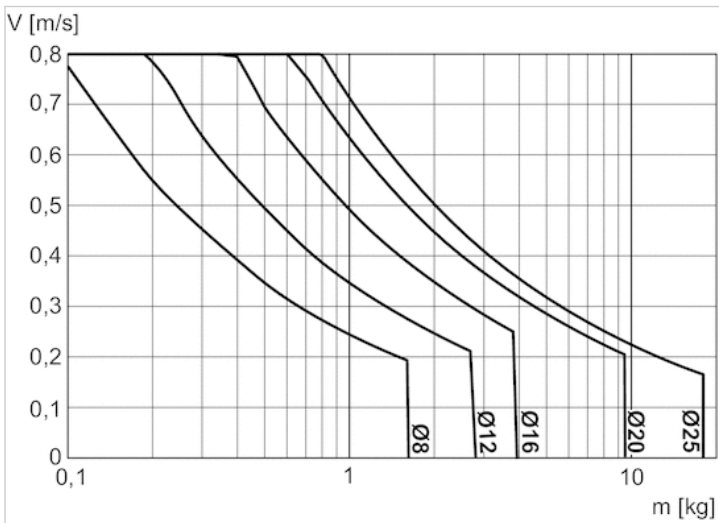

V = velocity [m/s]

m = mass

Correction factor for required speed: retracting and extending, horizontal

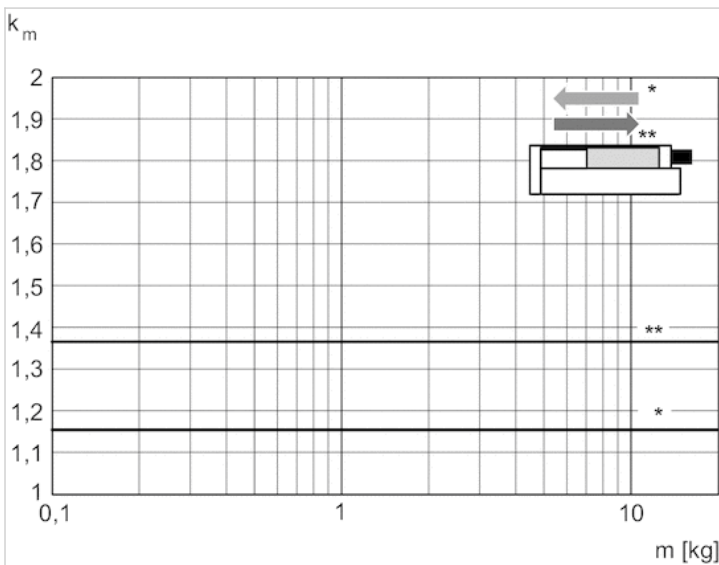

* retracting

** extracting

$$V = s / 1000 \cdot t \cdot km$$

V = velocity [m/s]

S = stroke

Correction factor for required speed: extending, vertical, upwards

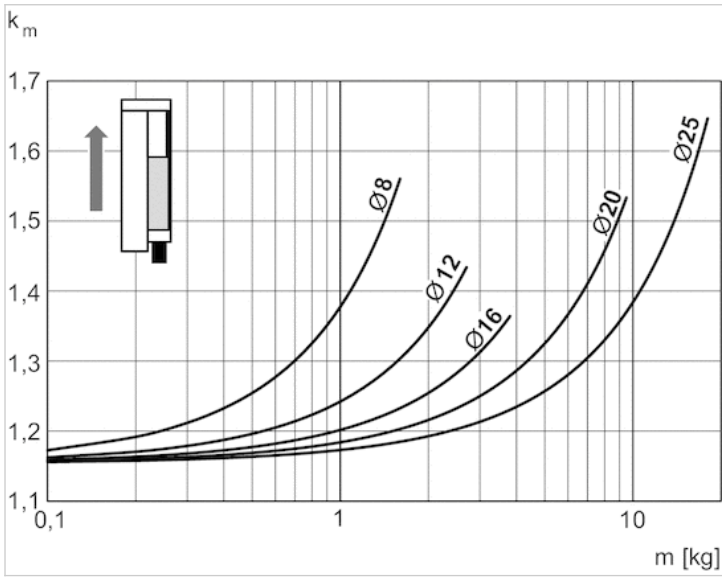

$V = s/1000 \cdot t \cdot k_m$
 V = velocity [m/s]
 S = stroke [mm]
 t = time [s] for one stroke
 m = mass

Correction factor for required speed: retracting, vertical, upwards

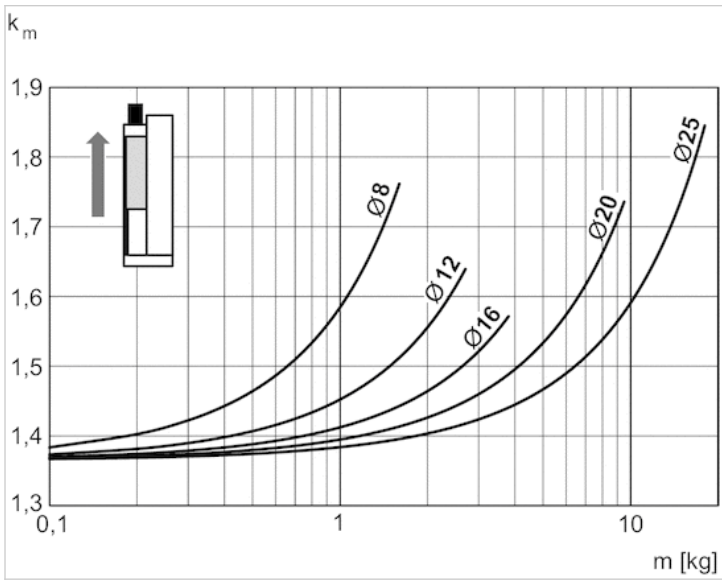

$V = s/1000 \cdot t \cdot k_m$
 V = velocity [m/s]
 S = stroke [mm]
 t = time [s] for one stroke
 m = mass

Correction factor for required speed: retracting, vertical, downwards

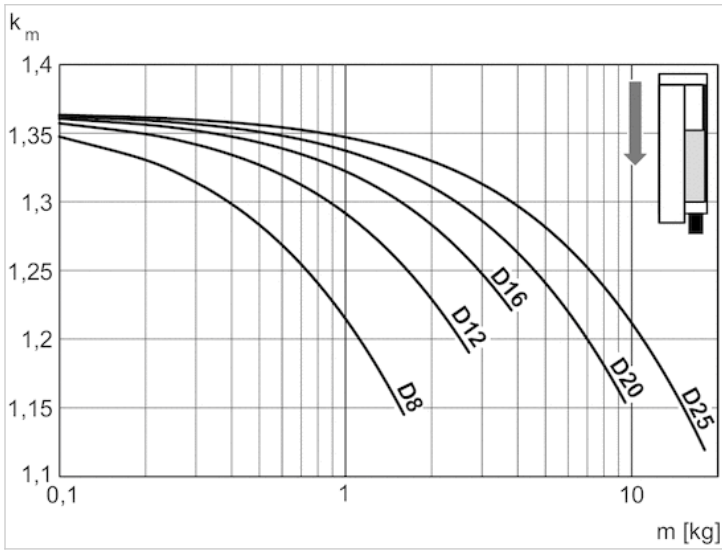

$V = s/1000 \cdot t \cdot k_m$
 V = velocity [m/s]
 S = stroke [mm]
 t = time [s] for one stroke
 m = mass

Correction factor for required speed: extending, vertical, downwards

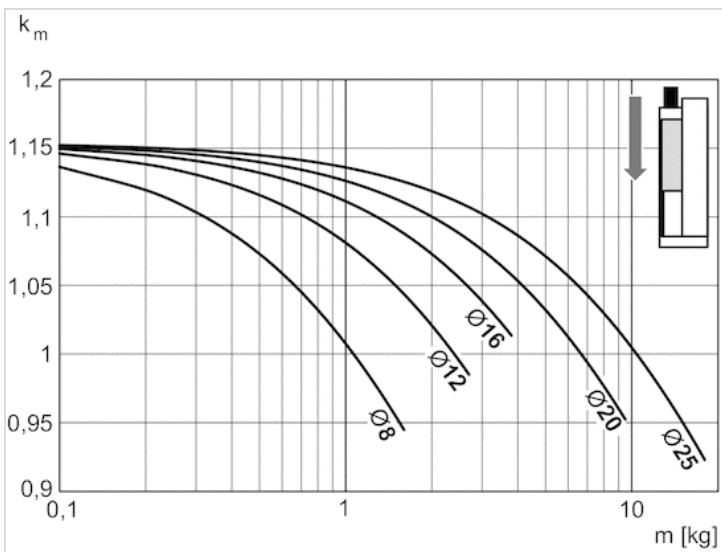

$V = s/1000 \cdot t \cdot k_m$
 V = velocity [m/s]
 S = stroke [mm]
 t = time [s] for one stroke
 m = mass

Extracting speed max.

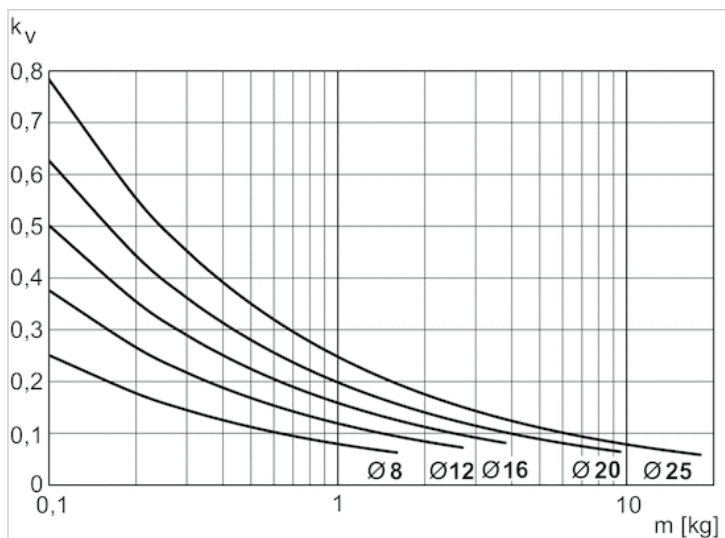

$V = \sqrt{s \cdot kv}$

V = velocity [m/s]

S = stroke [mm]

m = mass

Accessories overview

Overview drawing

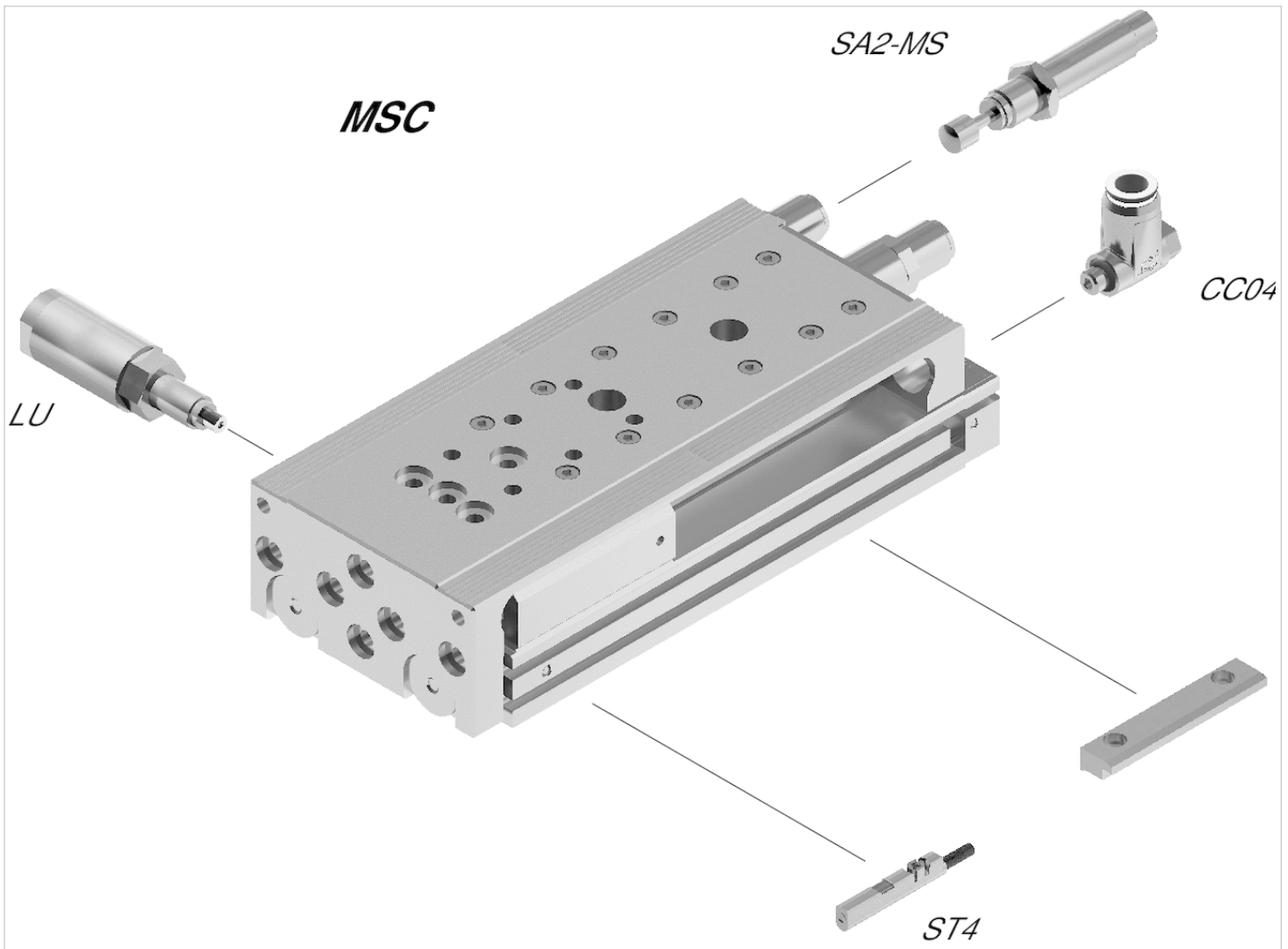

NOTE:

This overview drawing is only for orientation to indicate where the various accessory parts can be fastened to the cylinder. The illustration has been simplified for this purpose. It is thus not possible to derive the dimensions from this overview.

Mini slide, Series MSC-MG-PM/PE

- Scope of delivery: incl. centering rings
- Ø 16-25 mm
- double-acting
- with magnetic piston
- Cushioning pneumatically
- Easy2Combine capable
- with double piston
- With integrated ball rail system

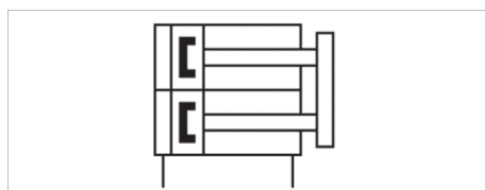

Working pressure min./max.	See table below
Ambient temperature min./max.	0 ... 60 °C
Medium	Compressed air
Max. particle size	5 µm
Oil content of compressed air	0 ... 1 mg/m ³
Pressure for determining piston forces	6.3 bar
Repetitive precision	0,3 mm
Weight	See table below

Technical data

Piston Ø	16 mm	20 mm	25 mm
Stroke 50	R480640154	R480640157	R480640160
80	R480640155	R480640158	R480640161
100	R480640156	R480640159	R480640162

Technical data

Piston Ø 2x	16 mm	20 mm	25 mm
Working pressure min./max.	3 ... 10 bar	3 ... 10 bar	2 ... 10 bar
Retracting piston force, theoretical	218 N	297 N	520 N
Extracting piston force, theoretical	182 N	269 N	421 N
Speed max.	0.8 m/s	0.8 m/s	0.8 m/s
Cushioning length	7 mm	7 mm	7 mm
Cushioning energy	0.5 J	1.2 J	1.6 J

Technical information

The pressure dew point must be at least 15 °C under ambient and medium temperature and may not exceed 3 °C .

The oil content of compressed air must remain constant during the life cycle.

Use only the approved oils from AVENTICS. Further information can be found in the “Technical information” document (available in the MediaCentre).

Repetitive precision after 100 consecutive strokes: 0,02 mm

Repeatability with variant with elastomer end stop: 0.3 mm

Cushioning length for variant with elastomer end stop: 10.5 mm

Base with air connections at the back and sides

Intermediate strokes can be configured.

Scope of delivery: incl. centering rings

R1 = stroke setting range for forward stroke

R2 = stroke setting range for return stroke

Technical information

Material	
Housing	Aluminum, anodized
Piston rod	Stainless steel
Front plate	Aluminum, anodized
Seal	Polyurethane
Ball rail table	Aluminum, anodized
Guide rail	Steel, hardened
Centering rings	Stainless steel

Dimensions

Dimensions

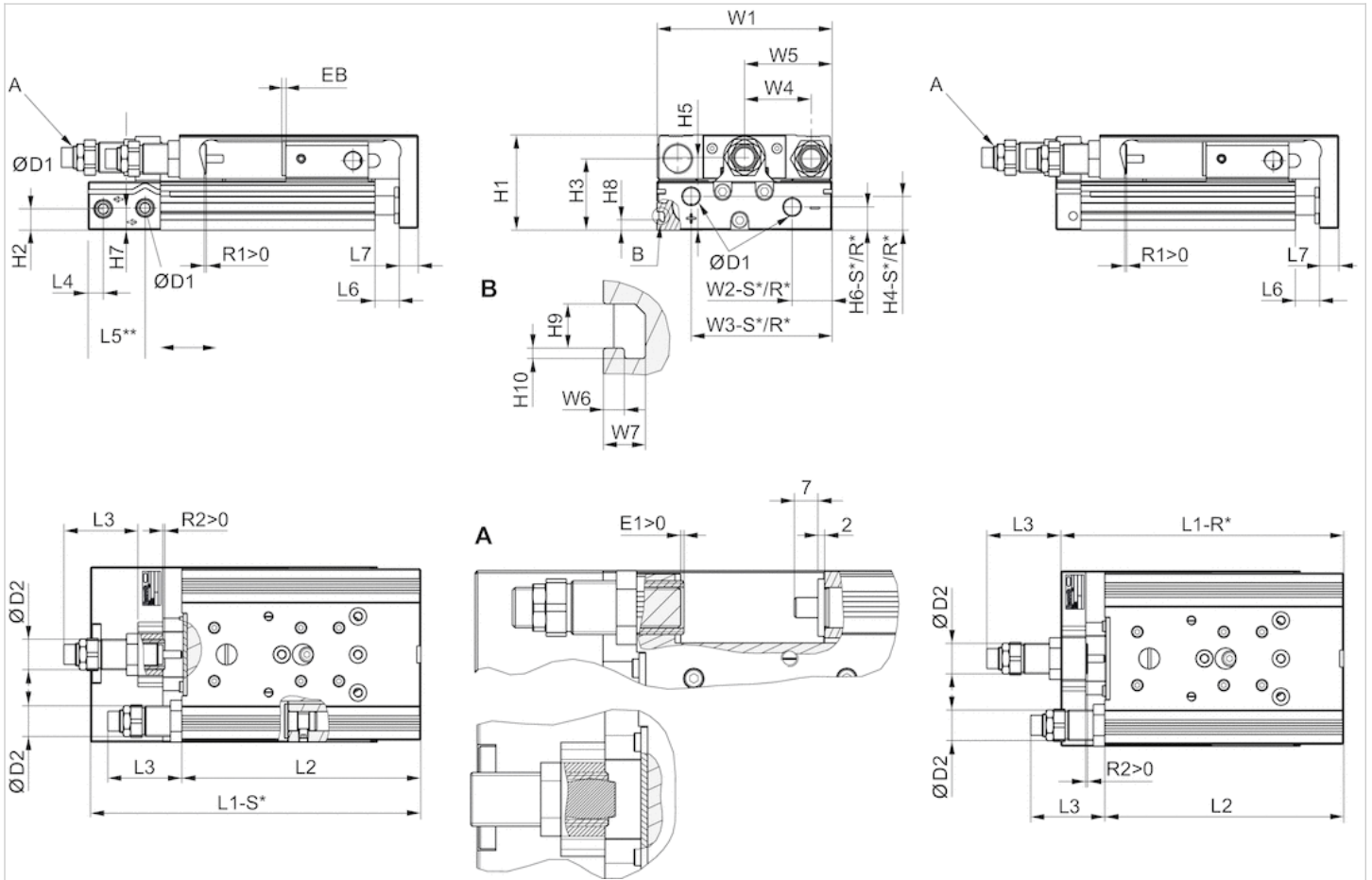

R*: base with air connections only at the back
 S*: base with air connections at the back and sides

Stroke-dependent dimensions

Piston Ø	S=50	S=80	S=100	S=50	S=80	S=100
	EB	EB	EB	L1-R	L1-R	L1-R
16 mm	2	2	2	126.8	172.8	192.8
20 mm	2	2	2	137.9	182.9	202.9
25 mm	2	2	2	149.1	195.1	215.1

Piston Ø	S=50	S=80	S=100	S=50	S=80	S=100
	L1-S	L1-S	L1-S	L2	L2	L2
16 mm	137.7	183.7	203.7	115.4	161.4	181.4
20 mm	162.8	207.8	227.8	125.5	170.5	190.5
25 mm	172.8	218.8	238.8	134.5	180.5	200.5

Piston Ø	S=50	S=80	S=100
	R1 max.	R1 max.	R1 max.
16 mm	8.7	8.7	8.7
20 mm	12.4	12.4	12.4
25 mm	10.5	11.5	11.5

Dimensions

Piston Ø	Ø D1	Ø D2	H1	H2	H3	H4-R	H4-S	H5	H6-R	H6-S	H7	H8	H9	H10	L3 1) max.
16 mm	M5	M12x1	40	7.2	29	12.2	12.2	31	7.7	7.7	11.2	-	-	-	12
20 mm	G 1/8	M16x1,5	50	11.2	37.5	17.3	17.3	38.2	11.7	12.2	11.7	5.5	4.2	1	15
25 mm	G 1/8	M18x1,5	60	14.2	44	15.5	22.9	46.5	13.2	21.7	16.2	6.9	5.2	1.5	15

Piston Ø	L3 2) max.	L4	L5 3)	L6	L7	R2	W1	W2-R	W2-S	W3-R	W3-S	W4	W5	W6	W7
16 mm	47	6.5	17.7	2	10	3	76	31	31	60.5	60.5	30	W1/2	-	-
20 mm	57	8	30	2.1	10	3	92	10	21	74	74	35	W1/2	2	4
25 mm	62	9	31	2.1	12	3	112	11	14	92	92	44	W1/2	2.5	4.8

Dimensions

MSC-16

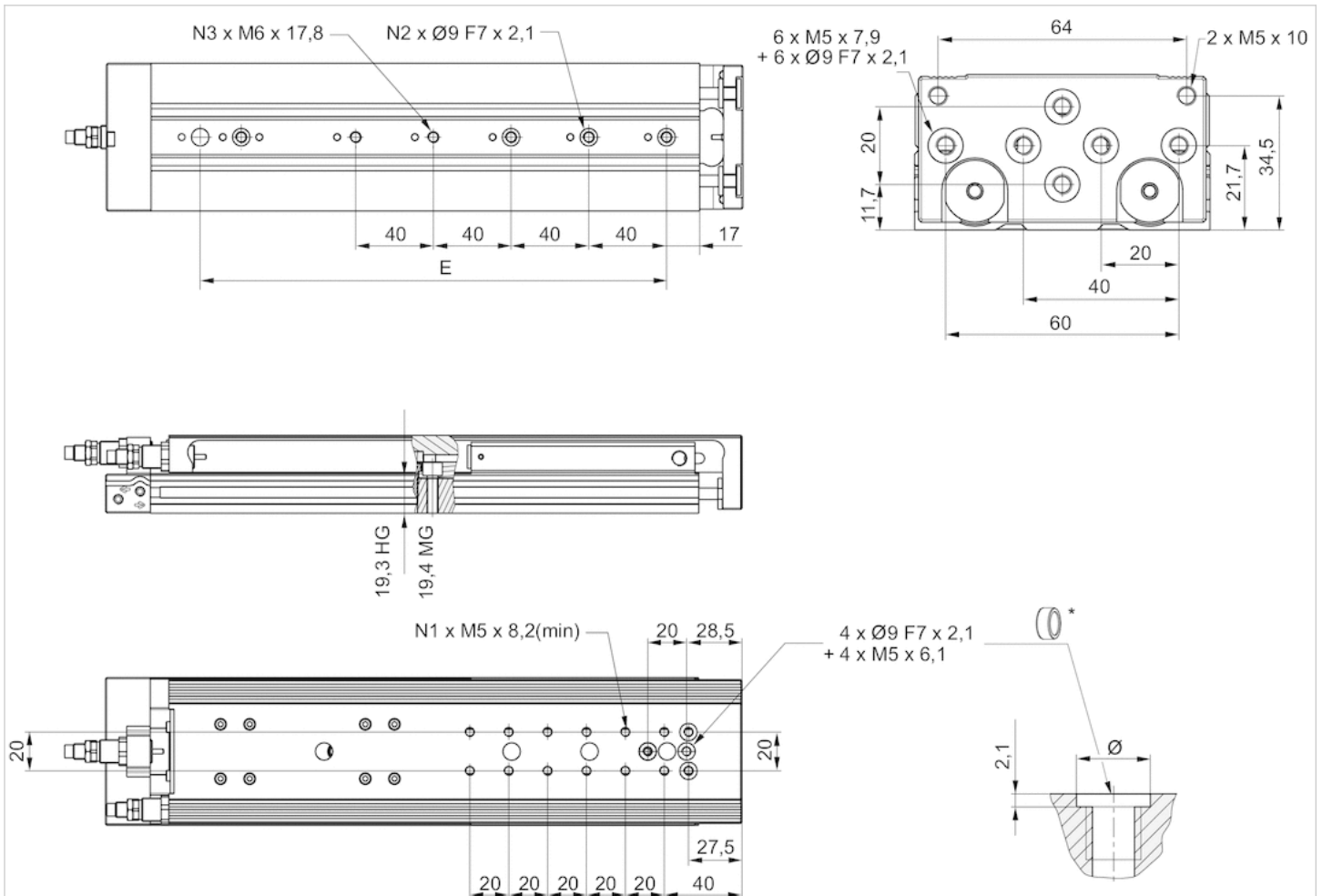

* = centering rings

Dimensions

Piston Ø	S	N1	N2	N3
16 mm	50	4	2	2
16 mm	80	6	3	3
16 mm	100	8	3	3

S = stroke

Dimensions

MSC-20

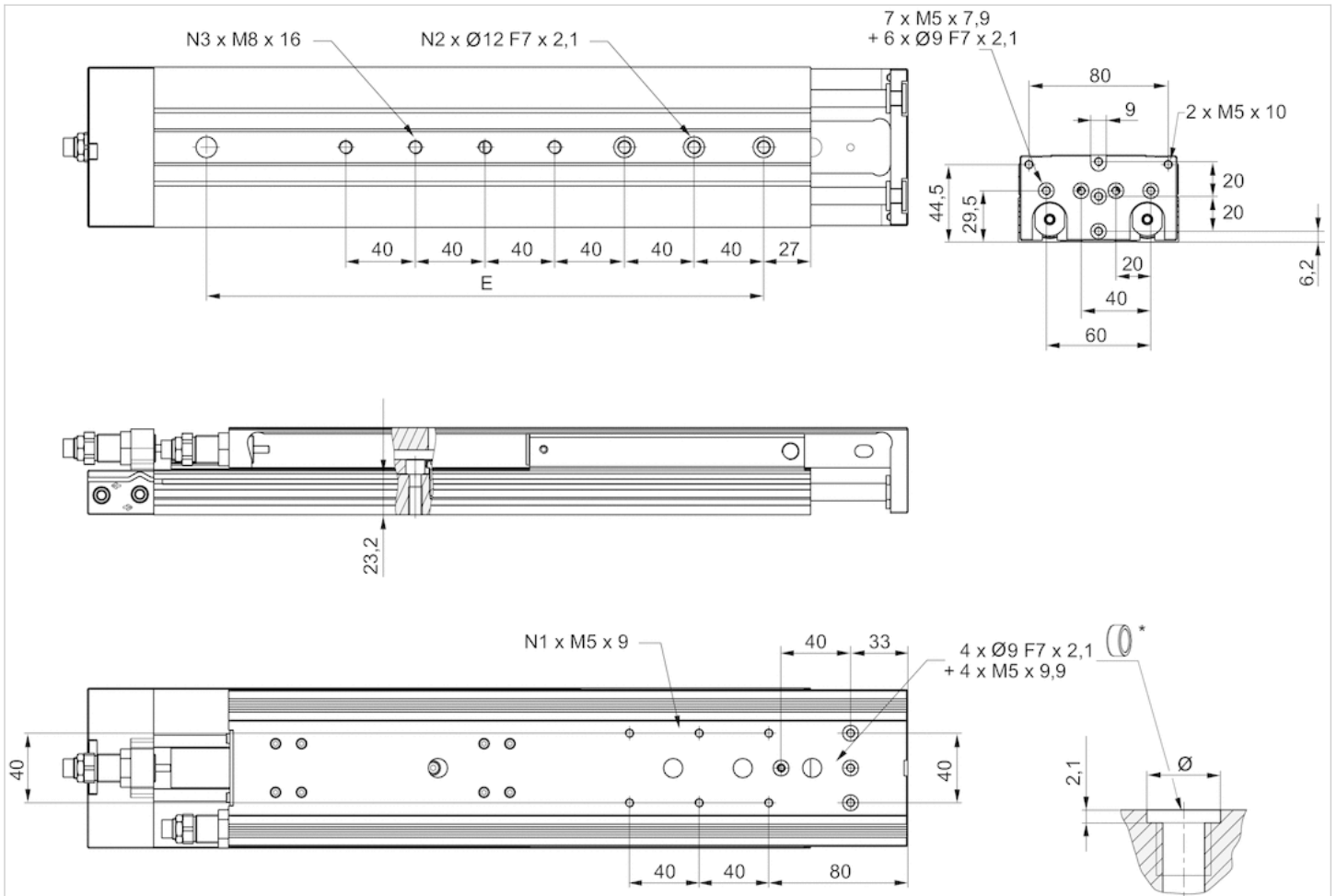

* = centering rings

Dimensions

Piston \varnothing	Stroke	N1	N2	N3
20 mm	50	2	2	2
20 mm	80	4	3	3
20 mm	100	4	3	3

Dimensions

MSC-25

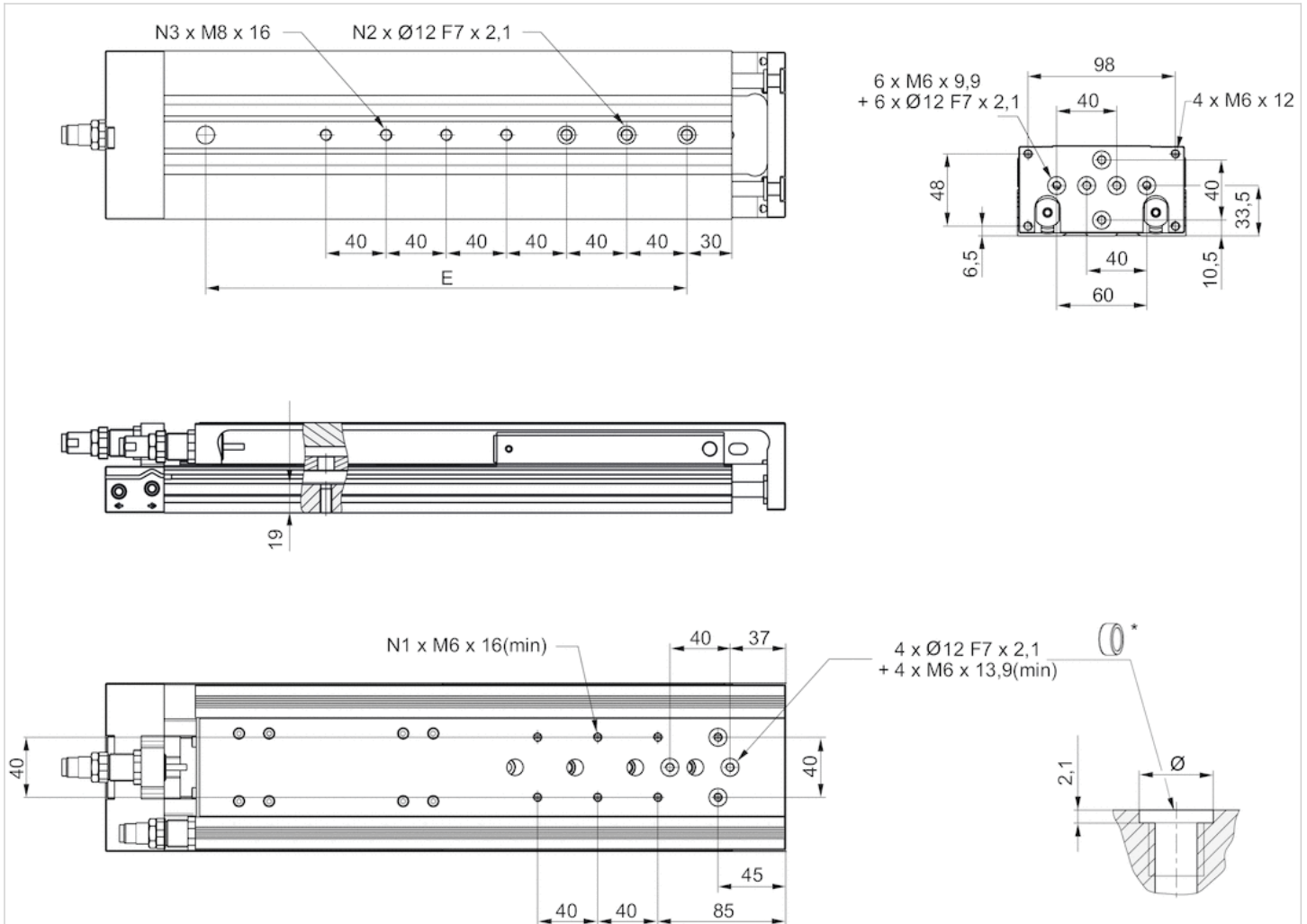

* = centering rings

Dimensions

Piston Ø	S	N1	N2	N3
25 mm	50	4	2	2
25 mm	80	4	3	3
25 mm	100	4	3	3

S = stroke

Weight of moving parts [kg]

Piston Ø	S=10	S=20	S=30	S=40	S=50	S=80	S=100	S=125	S=150	S=200
16 mm	0.375	0.375	0.375	0.4	0.45	0.615	0.65	0.725	0.765	–
20 mm	0.655	0.655	0.655	0.69	0.765	0.985	1.0345	1.2	1.29	1.54
20 mm	0.655	0.655	0.655	0.69	0.765	0.985	1.035	1.2	1.29	1.54
25 mm	1.1	1.1	1.1	1.1	1.225	1.45	1.625	1.885	2.085	2.445

S = stroke

Weight [kg]

Piston Ø	Stroke	Weight kg
16 mm	50	1.29 kg
20 mm	50	1.61 kg
25 mm	50	2.64 kg

Dimensions

Load capacity

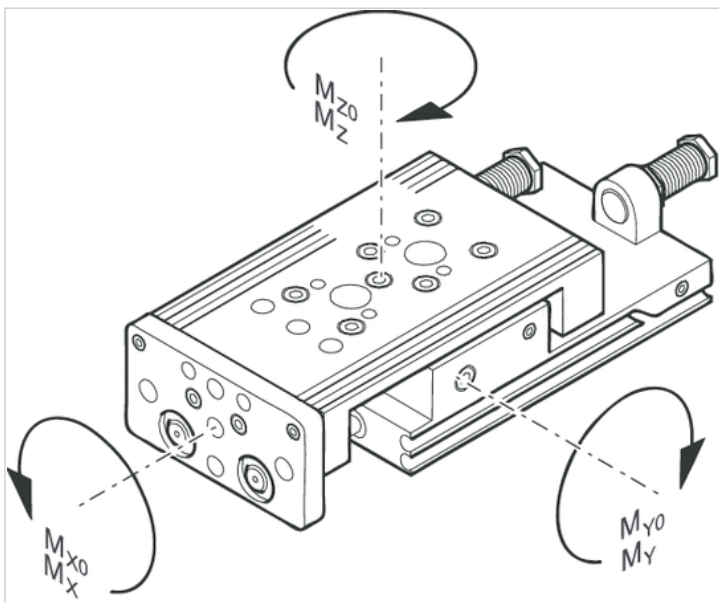

M = max. permissible torque

correction factor (a)

Piston Ø	Stroke	a [mm]	d [mm]	Mx0 Static moment M [Nm]
16 mm	50	86	15	31,6
20 mm	50	92	20	31,6
25 mm	50	102	24	87

My0 Static moment M [Nm]	Mz0 Static moment M [Nm]	Mx Dynamic moment M [Nm]
11,95	11,95	7
11,95	11,95	10
24,5	24,5	15,3

My Dynamic moment M [Nm]	Mz Dynamic moment M [Nm]
3,2	3,2
4	4
6,6	6,6

Dimensions

correction factor (a, d)

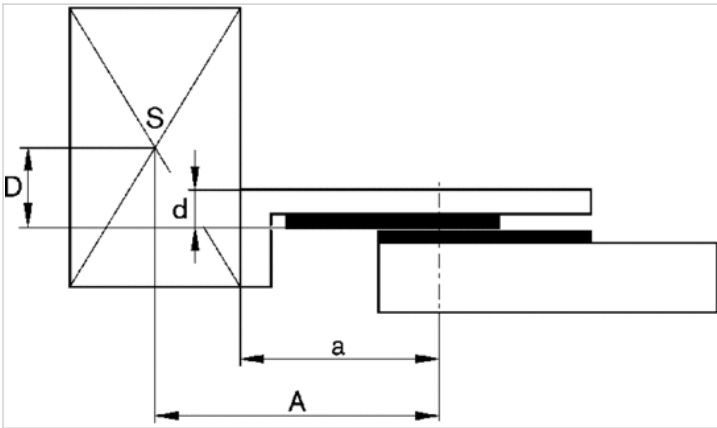

horizontal

stat.	$M_{B0} = F_G \cdot A + F \cdot D$
dyn.	$M_B = F_G \cdot A$

stat.	$M_{C0} = F_G \cdot B$
dyn.	$M_C = F_G \cdot B$

stat.	$M_{A0} = F \cdot B$
dyn.	$M_A = 0$

dyn.	$\frac{M_A}{M_1} + \frac{M_B}{M_2} + \frac{M_C}{M_3} \leq 1$
stat.	$\frac{M_{A0}}{M_{20}} + \frac{M_{B0}}{M_{V0}} + \frac{M_{C0}}{M_{X0}} \leq 1$

$F = m \cdot a$

$FG = m \cdot g$

$a = 1250 \cdot V^2 / H$

F = deceleration force [N]

FG = force due to weight [N]

m = load mass [kg]

a = deceleration [m/s²]

g = gravitational acceleration 9,81 [m/s²]

V = velocity [m/s]

H = stroke length of shock absorber [mm]

vertical

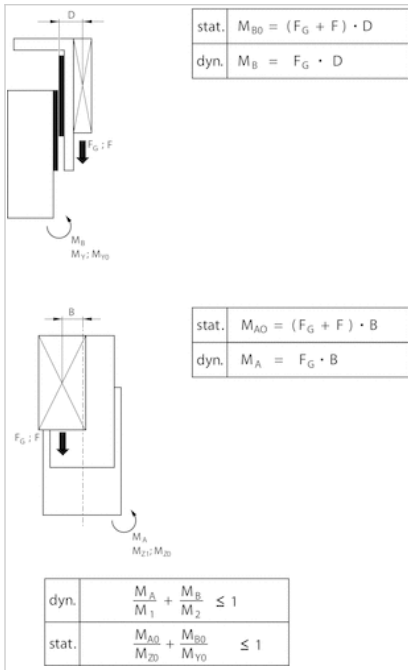

$F = m \cdot a$
 $FG = m \cdot g$
 $a = 1250 \cdot V^2 / H$

- F = deceleration force [N]
- FG= force due to weight [N]
- m = load mass [kg]
- a = deceleration [m/s²]
- g = gravitational acceleration 9,81 [m/s²]
- V = velocity [m/s]
- H = stroke length of shock absorber [mm]

Diagrams

Maximum moving mass

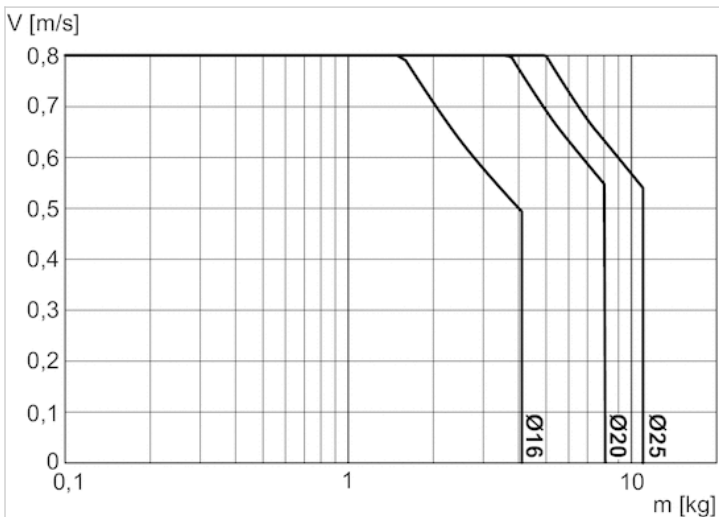

V = velocity [m/s]
 m = mass

Correction factor for required speed: retracting and extending, horizontal

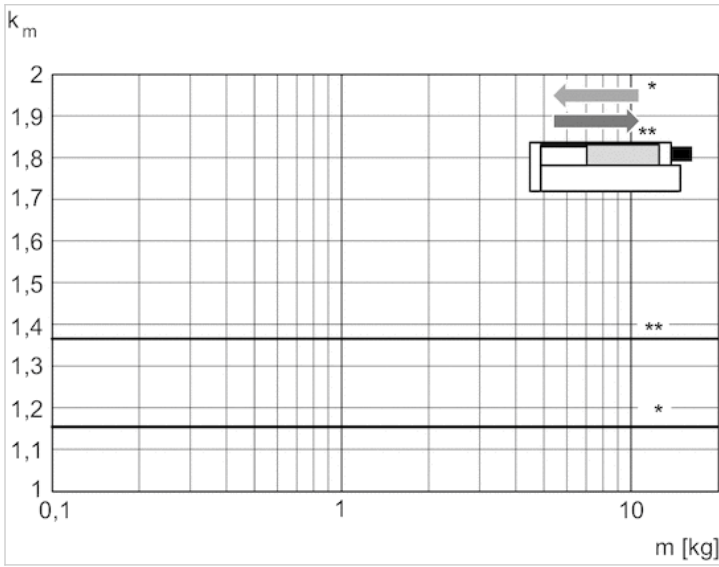

* retracting
 ** extracting
 $V = s/1000 \cdot t \cdot km$
 V = velocity [m/s]
 S = stroke

Correction factor for required speed: extending, vertical, upwards

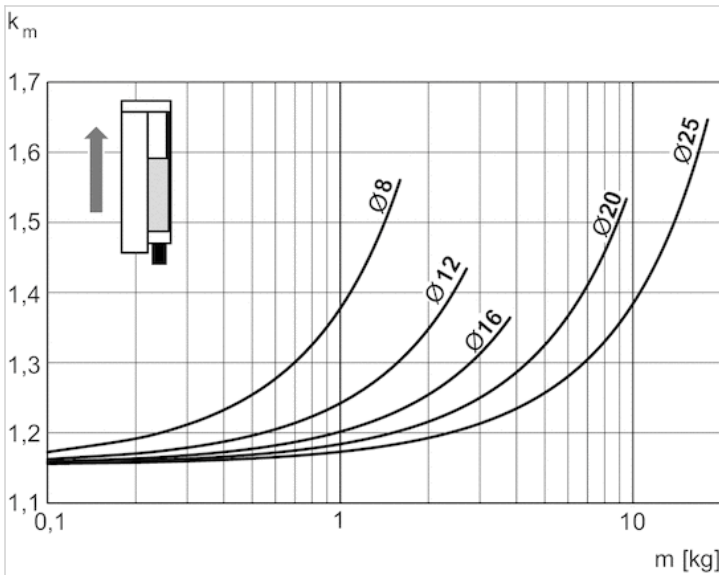

$V = s/1000 \cdot t \cdot km$
 V = velocity [m/s]
 S = stroke [mm]
 t = time [s] for one stroke
 m = mass

Correction factor for required speed: retracting, vertical, upwards

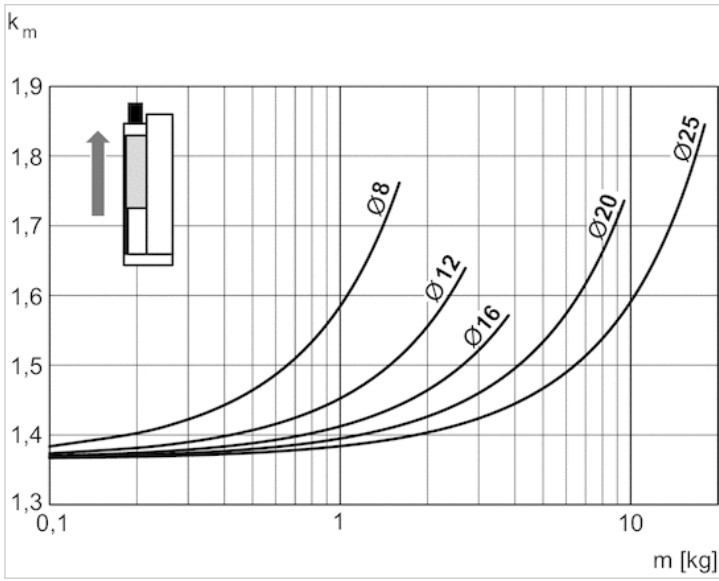

$V = s/1000 \cdot t \cdot k_m$
 $V =$ velocity [m/s]
 $S =$ stroke [mm]
 $t =$ time [s] for one stroke
 $m =$ mass

Correction factor for required speed: retracting, vertical, downwards

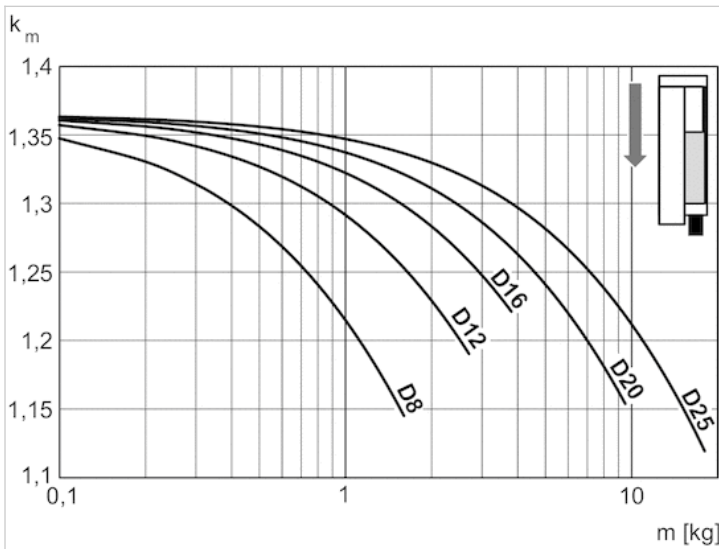

$V = s/1000 \cdot t \cdot k_m$
 $V =$ velocity [m/s]
 $S =$ stroke [mm]
 $t =$ time [s] for one stroke
 $m =$ mass

Correction factor for required speed: extending, vertical, downwards

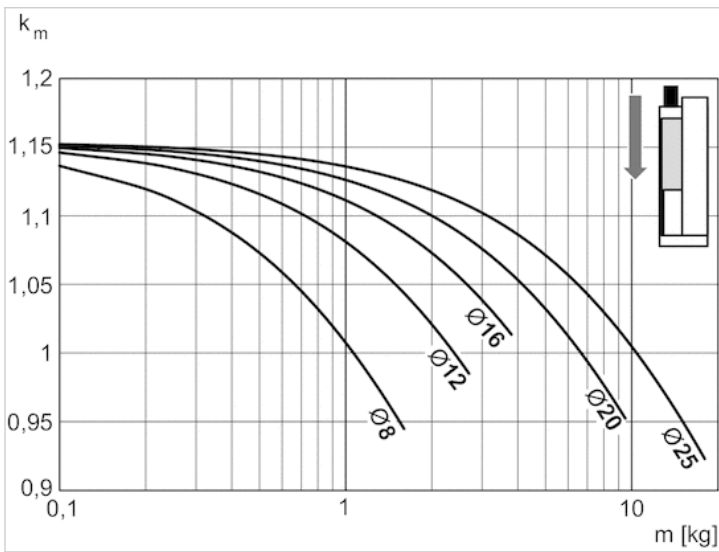

$V = s/1000 \cdot t \cdot k_m$
 $V = \text{velocity [m/s]}$
 $S = \text{stroke [mm]}$
 $t = \text{time [s] for one stroke}$
 $m = \text{mass}$

Extracting speed max.

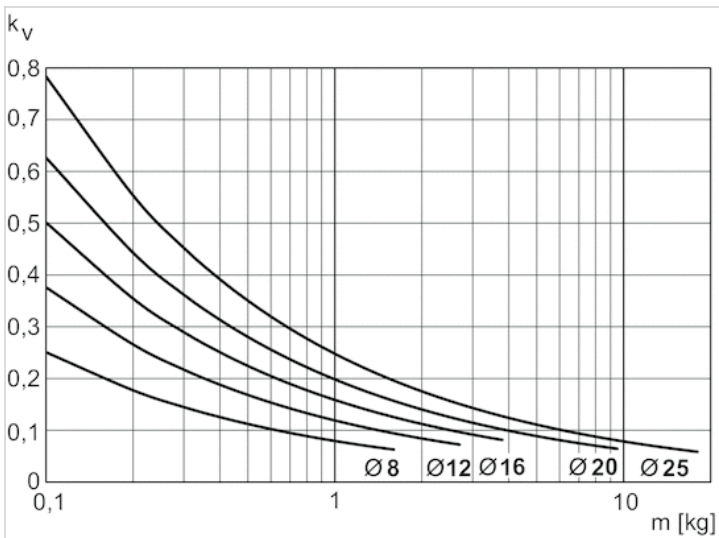

$V = \sqrt{s \cdot k_v}$
 $V = \text{velocity [m/s]}$
 $S = \text{stroke [mm]}$
 $m = \text{mass}$

Accessories overview

Overview drawing

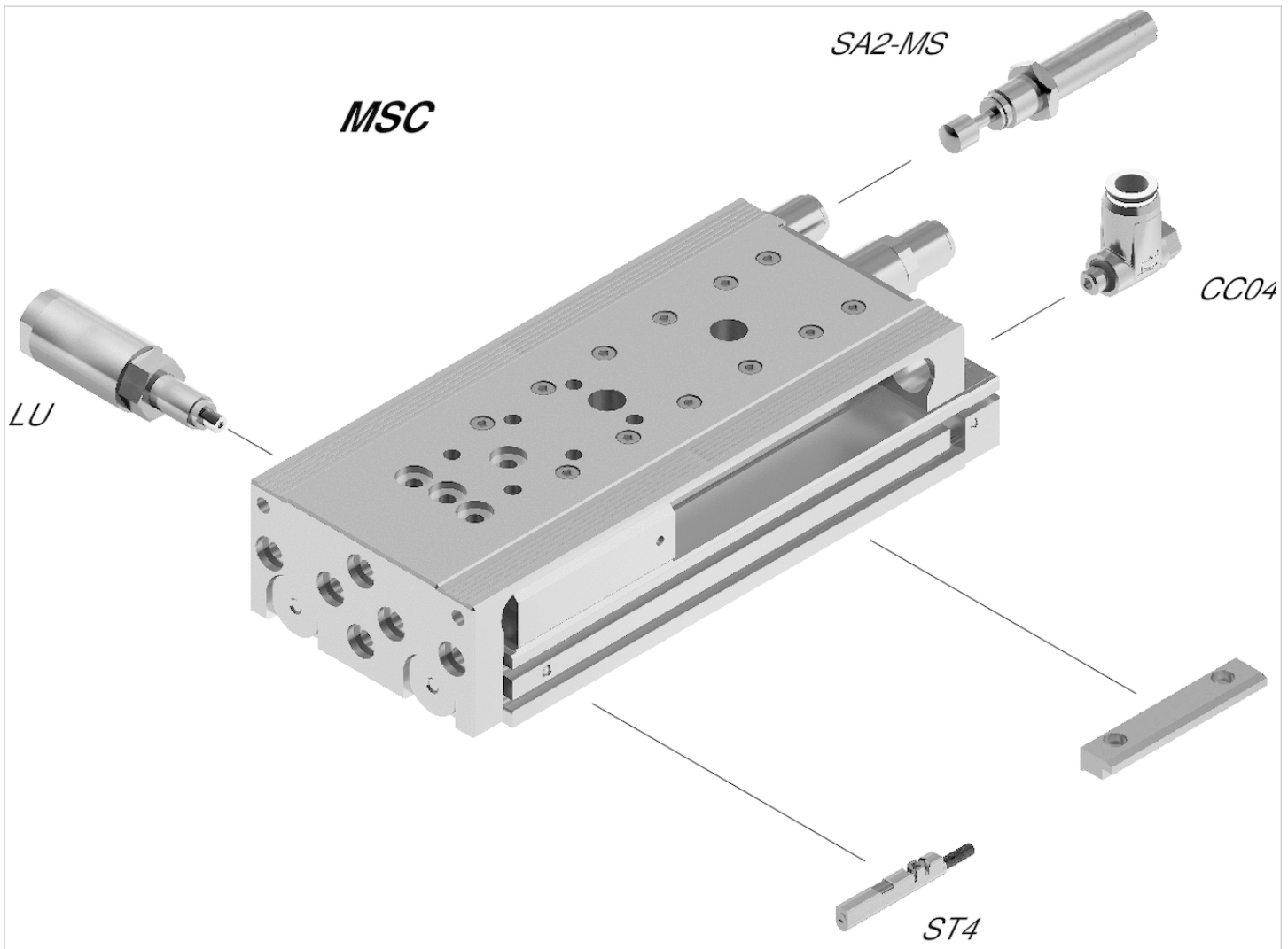

NOTE:

This overview drawing is only for orientation to indicate where the various accessory parts can be fastened to the cylinder. The illustration has been simplified for this purpose. It is thus not possible to derive the dimensions from this overview.

Mini slide, Series MSC-MG-HM

- Scope of delivery: incl. centering rings
- Ø 8-25 mm
- double-acting
- with magnetic piston
- Cushioning hydraulic
- Easy2Combine capable
- with double piston
- With integrated ball rail system

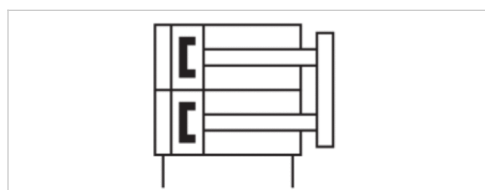

Working pressure min./max.	See table below
Ambient temperature min./max.	0 ... 60 °C
Medium	Compressed air
Max. particle size	5 µm
Oil content of compressed air	0 ... 1 mg/m ³
Pressure for determining piston forces	6.3 bar
Repetitive precision	0,02 mm
Weight	See table below

Technical data

Piston Ø	8 mm	12 mm	16 mm	20 mm	25 mm
Stroke 20	R480640164	-	-	-	-
30	R480640165	R480640171	R480640178	R480640185	R480640192
40	R480640166	R480640172	R480640179	R480640186	R480640193
50	R480640167	R480640173	R480640180	R480640187	R480640194
80	R480640168	R480640174	R480640181	R480640188	R480640195
100	-	R480640175	R480640182	R480640189	R480640196

Technical data

Piston Ø 2x	8 mm	12 mm	16 mm	20 mm
Working pressure min./max.	1.5 ... 10 bar	1 ... 10 bar	1 ... 10 bar	1 ... 10 bar
Retracting piston force, theoretical	48 N	107 N	218 N	297 N
Extracting piston force, theoretical	63 N	143 N	253 N	396 N
Speed max.	0.8 m/s	0.8 m/s	0.8 m/s	0.8 m/s
Cushioning length	5 mm	7 mm	7 mm	10 mm
Cushioning energy	0.6 J	1 J	1.2 J	3.1 J

Piston Ø 2x	25 mm
Working pressure min./max.	1 ... 10 bar
Retracting piston force, theoretical	520 N
Extracting piston force, theoretical	619 N
Speed max.	0.8 m/s
Cushioning length	14 mm
Cushioning energy	5.8 J

Technical information

The pressure dew point must be at least 15 °C under ambient and medium temperature and may not exceed 3 °C .

The oil content of compressed air must remain constant during the life cycle.

Use only the approved oils from AVENTICS. Further information can be found in the "Technical information" document (available in the MediaCentre).

Repetitive precision after 100 consecutive strokes: 0,02 mm

Base with air connections at the back and sides

Intermediate strokes can be configured.

Scope of delivery: incl. centering rings

R1 = stroke setting range for forward stroke

R2 = stroke setting range for return stroke

Technical information

Material	
Housing	Aluminum, anodized
Piston rod	Stainless steel
Front plate	Aluminum, anodized
Seal	Polyurethane
Ball rail table	Aluminum, anodized
Guide rail	Steel, hardened
Centering rings	Stainless steel

Dimensions

Dimensions

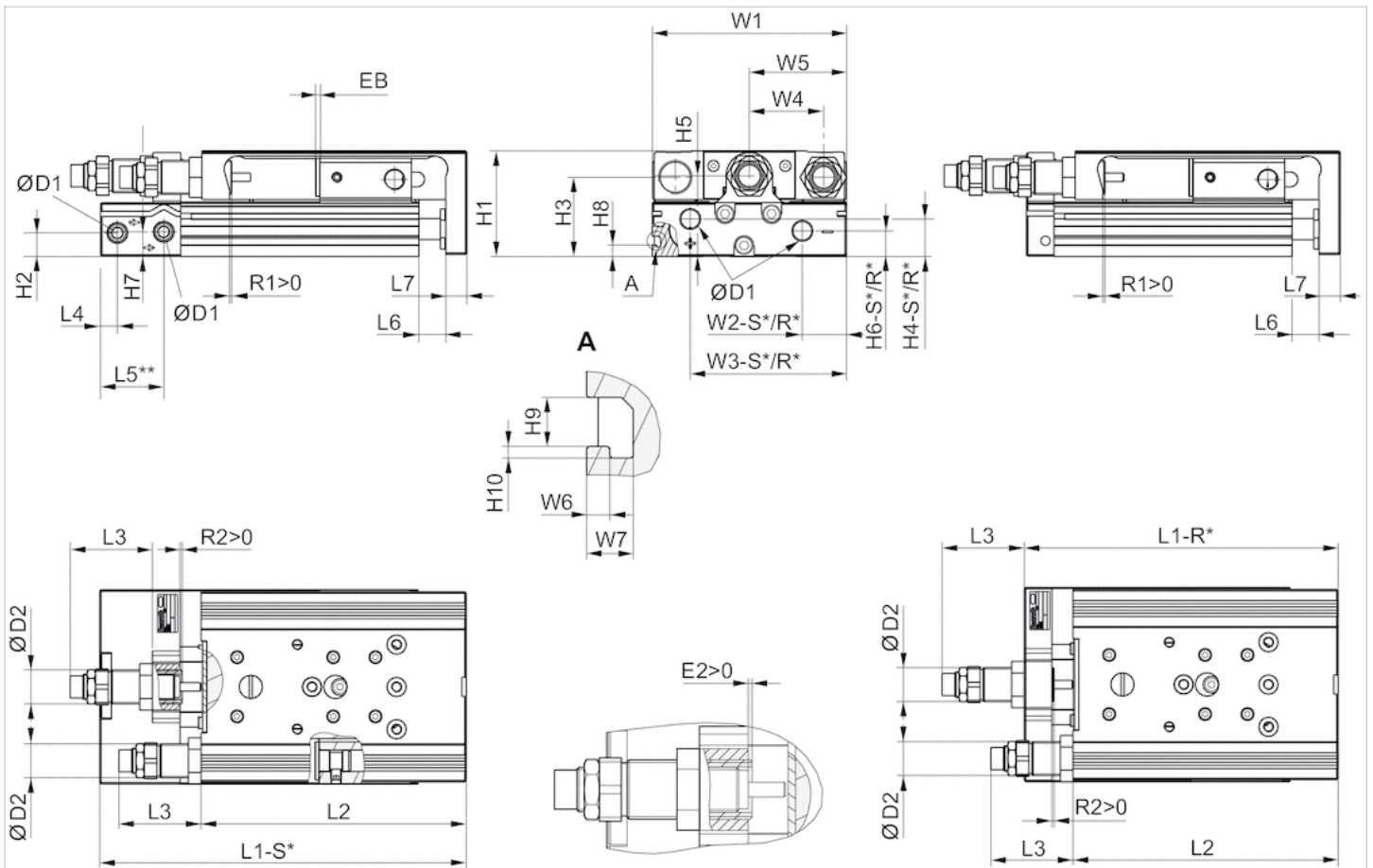

R*: base with air connections only at the back
 S*: base with air connections at the back and sides
 ** Ø 8 has a different reference plane.

Dimensions

Piston Ø	Ø D1	Ø D2	H1	H2	H3	H4-R	H4-S	H5	H6-R	H6-S	H7	H8	H9	H10	L3 max.	L4
8 mm	M5	M10x1	28	9.6	20.5	-	7.5	19.5	-	5.5	18	-	-	-	31	9.8
12 mm	M5	M12x1	34	5.7	25	11.2	11.2	24.5	5.7	5.7	8.3	-	-	-	46.7	7.2
16 mm	M5	M12x1	40	7.2	29	12.2	12.2	31	7.7	7.7	11.2	-	-	-	44.9	6.5
20 mm	G 1/8	M16x1,5	50	11.2	37.5	17.3	17.3	38.2	11.7	12.2	11.7	5.5	4.2	1	48.9	8
25 mm	G 1/8	M18x1,5	60	14.2	44	15.5	22.9	46.5	13.2	21.7	16.2	6.9	5.2	1.5	67.7	9

Piston Ø	L5 2)	L6	L7	R2	W1	W2-R	W2-S	W3-R	W3-S	W4	W5	W6	W7
8 mm	-	1.9	6	1.9	50.2	-	19.3	-	30.5	18	W1/2	-	-
12 mm	22.5	2	8	2	66	28.8	28.8	53	53	24.5	W1/2	-	-
16 mm	17.7	2	10	2	76	31	31	60.5	60.5	30	W1/2	-	-
20 mm	30	2.1	10	2.1	92	10	21	74	74	35	W1/2	2	4
25 mm	31	2.1	12	2.1	112	11	14	92	92	44	W1/2	2.5	4.8

Stroke-dependent dimensions

Piston Ø	S=10 EB	S=20 EB	S=30 EB	S=40 EB	S=50 EB	S=80 EB
8 mm	32	22	12	2	2	2
16 mm	22	12	2	2	2	2
20 mm	22	12	2	2	2	2
25 mm	32	22	12	2	2	2

Piston Ø	S=100 EB	S=10 L1-R	S=20 L1-R	S=30 L1-R	S=40 L1-R	S=50 L1-R
8 mm	–	–	–	–	–	–
16 mm	2	101.8	101.8	101.8	111.8	126.8
20 mm	2	112.9	112.9	112.9	122.9	137.9
25 mm	2	136.1	136.1	136.1	136.1	149.1

Piston Ø	S=80 L1-R	S=100 L1-R	S=10 L1-S	S=20 L1-S	S=30 L1-S
8 mm	–	–	100.7	100.7	100.7
16 mm	172.8	192.8	112.7	112.7	112.7
20 mm	182.9	202.9	137.8	137.8	137.8
25 mm	195.1	215.1	159.8	159.8	159.8

Piston Ø	S=40 L1-S	S=50 L1-S	S=80 L1-S	S=100 L1-S	S=10 L2	S=20 L2
8 mm	100.7	120.7	170.7	–	93.5	93.5
16 mm	122.7	137.7	183.7	203.7	90.4	90.4
20 mm	147.8	162.8	207.8	227.8	100.5	100.5
25 mm	159.8	172.8	218.8	238.8	121.5	121.5

Piston Ø	S=30 L2	S=40 L2	S=50 L2	S=80 L2	S=100 L2	S=10 R1 max.
8 mm	93.5	93.5	113.5	163.5	–	4.2
16 mm	90.4	100.4	115.4	161.4	181.4	8.7
20 mm	100.5	110.5	125.5	170.5	190.5	12.4
25 mm	121.5	121.5	134.5	180.5	200.5	11.5

Piston Ø	S=20 R1 max.	S=30 R1 max.	S=40 R1 max.	S=50 R1 max.
8 mm	4.2	4.2	4.2	4.2
16 mm	8.7	8.7	8.7	8.7
20 mm	12.4	12.4	12.4	12.4
25 mm	11.5	11.5	11.5	10.5

Piston Ø	S=80 R1 max.	S=100 R1 max.	S=10 R2 max.	S=20 R2 max.
8 mm	4.2	–	4.1	4.1
16 mm	8.7	8.7	1.5	1.5
20 mm	12.4	12.4	1.5	1.5
25 mm	11.5	11.5	7.5	7.5

Piston Ø	S=30 R2 max.	S=40 R2 max.	S=50 R2 max.	S=80 R2 max.
8 mm	4.1	4.1	4.1	4.1

Piston Ø	S=30 R2 max.	S=40 R2 max.	S=50 R2 max.	S=80 R2 max.
16 mm	1.5	1.5	6	7
20 mm	1.5	11.5	9.5	14
25 mm	7.5	7.5	3.3	7.5

Piston Ø	S=100 R2 max.
8 mm	-
16 mm	5.7
20 mm	14
25 mm	9.2

Dimensions

MSC-08

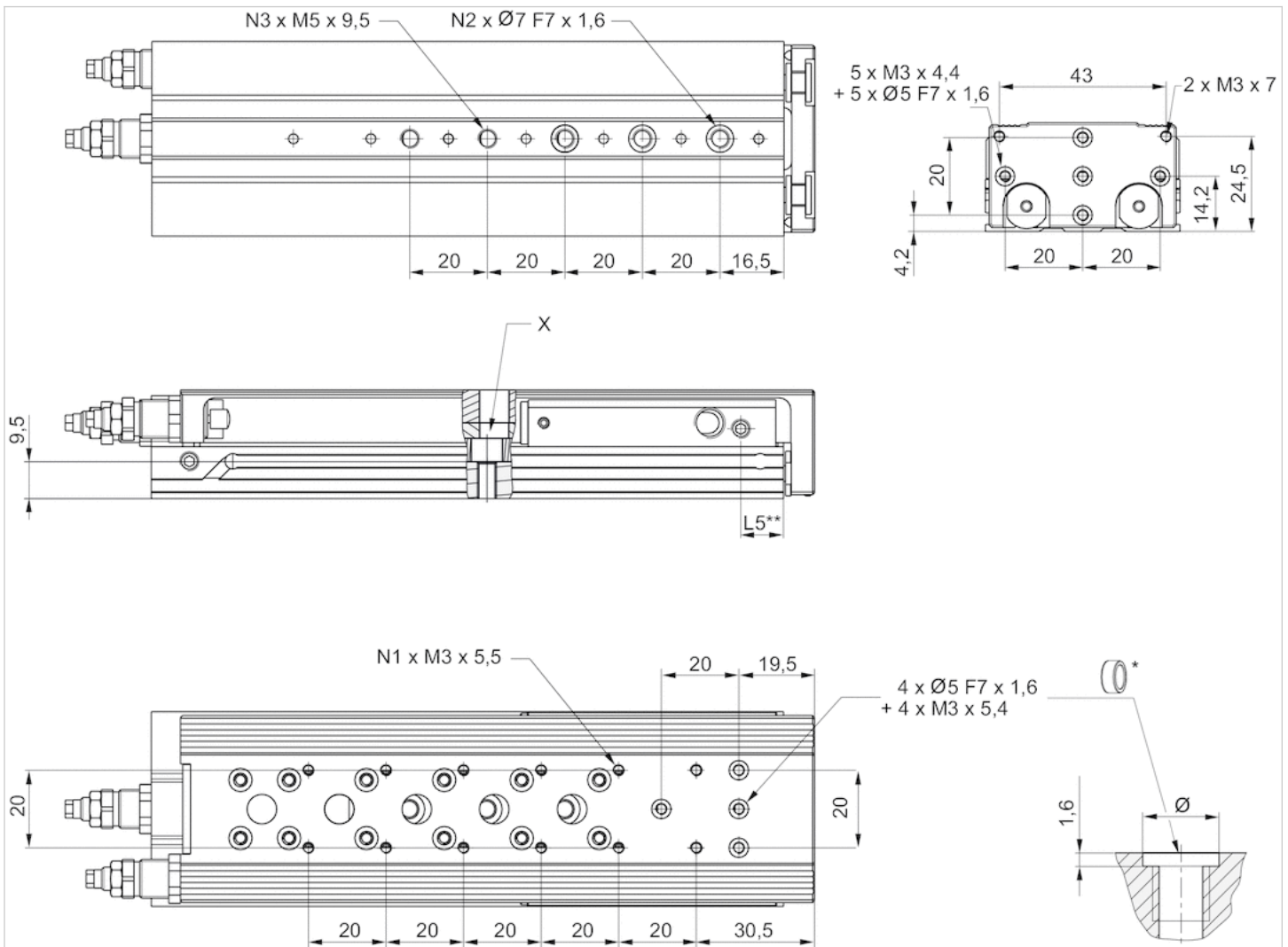

* = centering rings

** Ø 8 has a different reference plane.

Dimensions

Piston Ø	S	N1	N2	N3	L5	X
8 mm	20	4	2	2	11	-
8 mm	30	4	2	2	11	-
8 mm	40	6	2	2	11	-
8 mm	50	8	3	3	11	1)
8 mm	80	12	3	5	11	-

S = stroke

1) Access to the through hole only after removal of the stroke limitation bolts

Dimensions

MSC-12

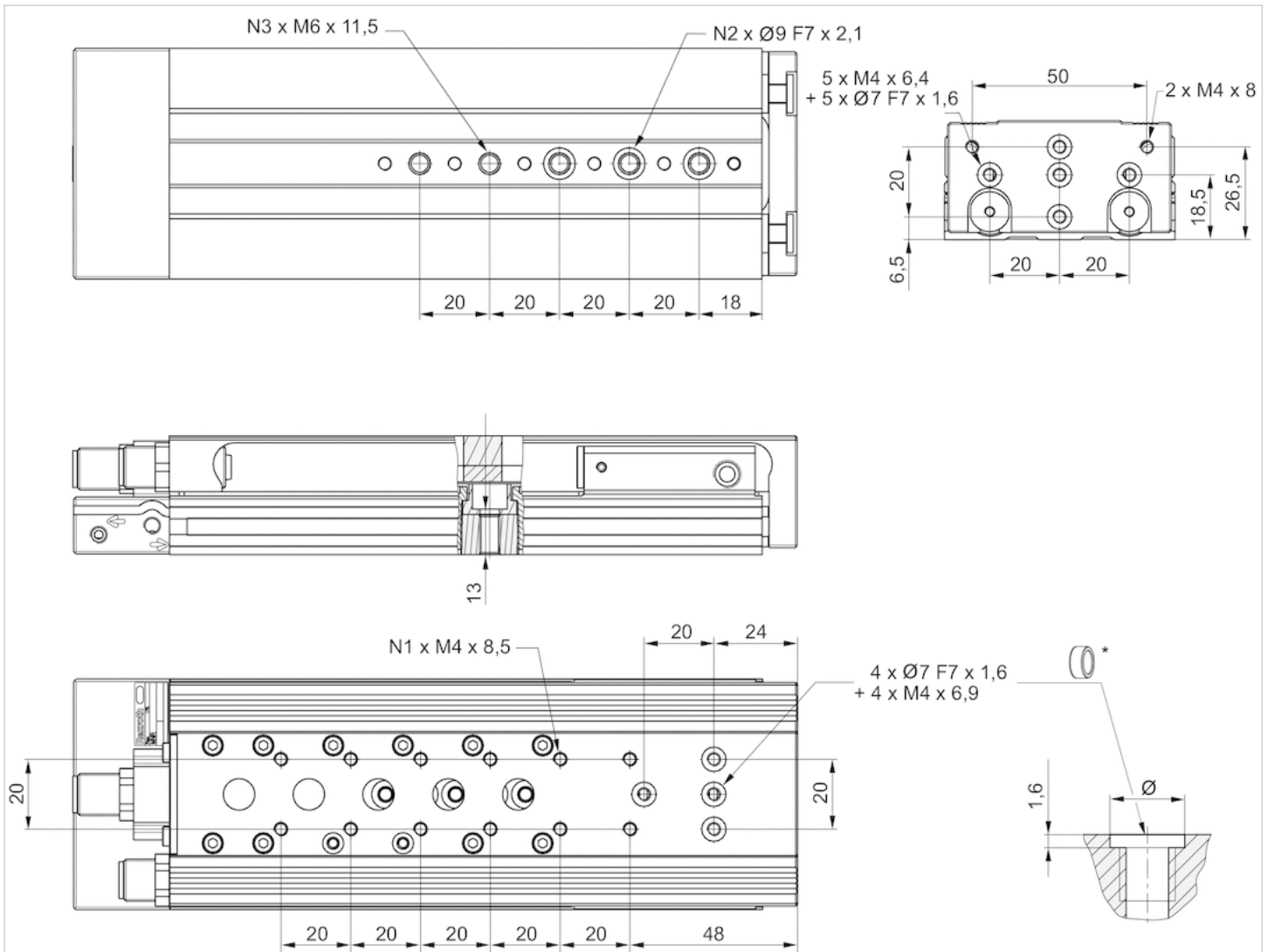

* = centering rings

Dimensions

Piston Ø	S	N1	N2	N3
12 mm	30	2	2	2
12 mm	40	2	2	2
12 mm	50	4	3	3
12 mm	80	6	3	5
12 mm	100	8	3	5

S = stroke

Dimensions

MSC-16

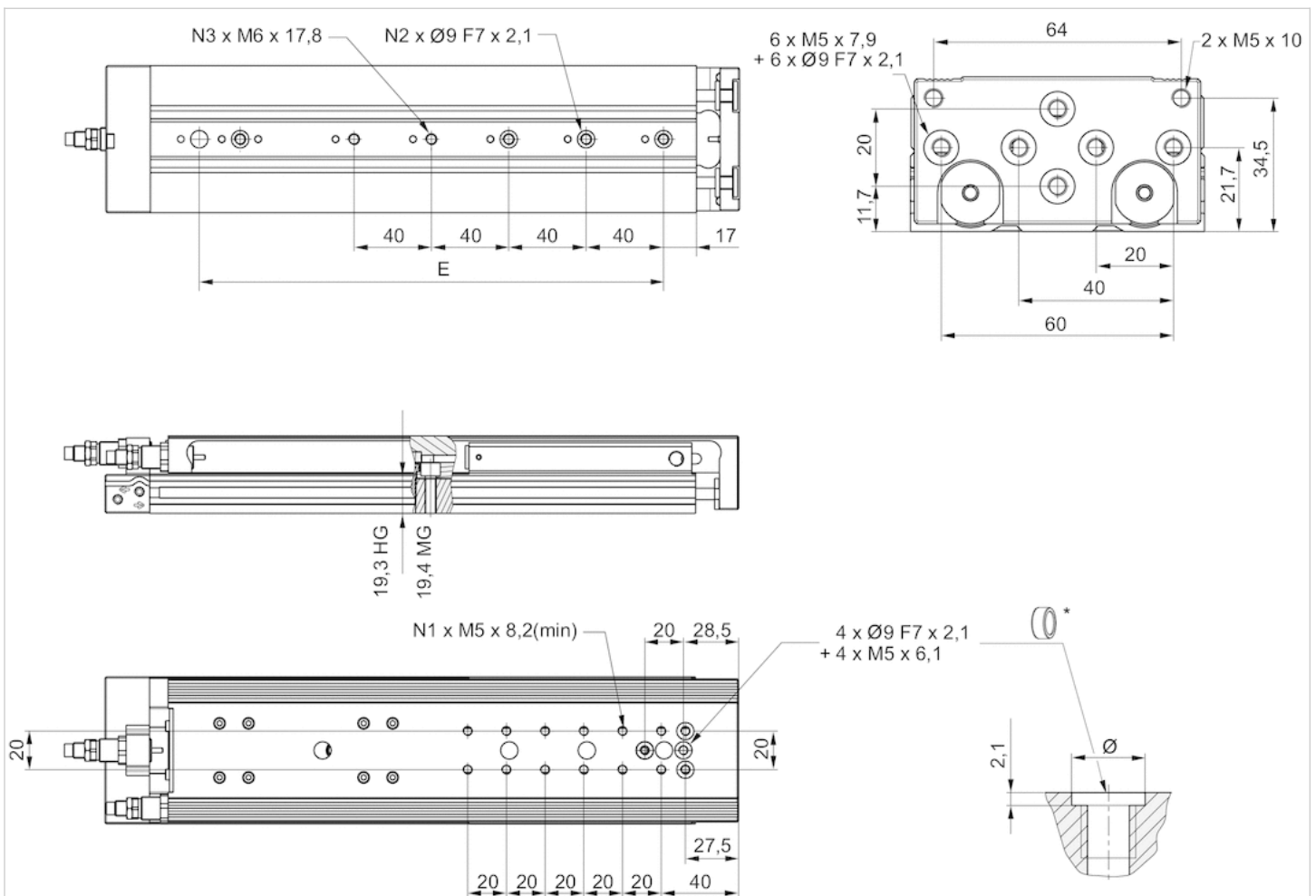

* = centering rings

MSC-20

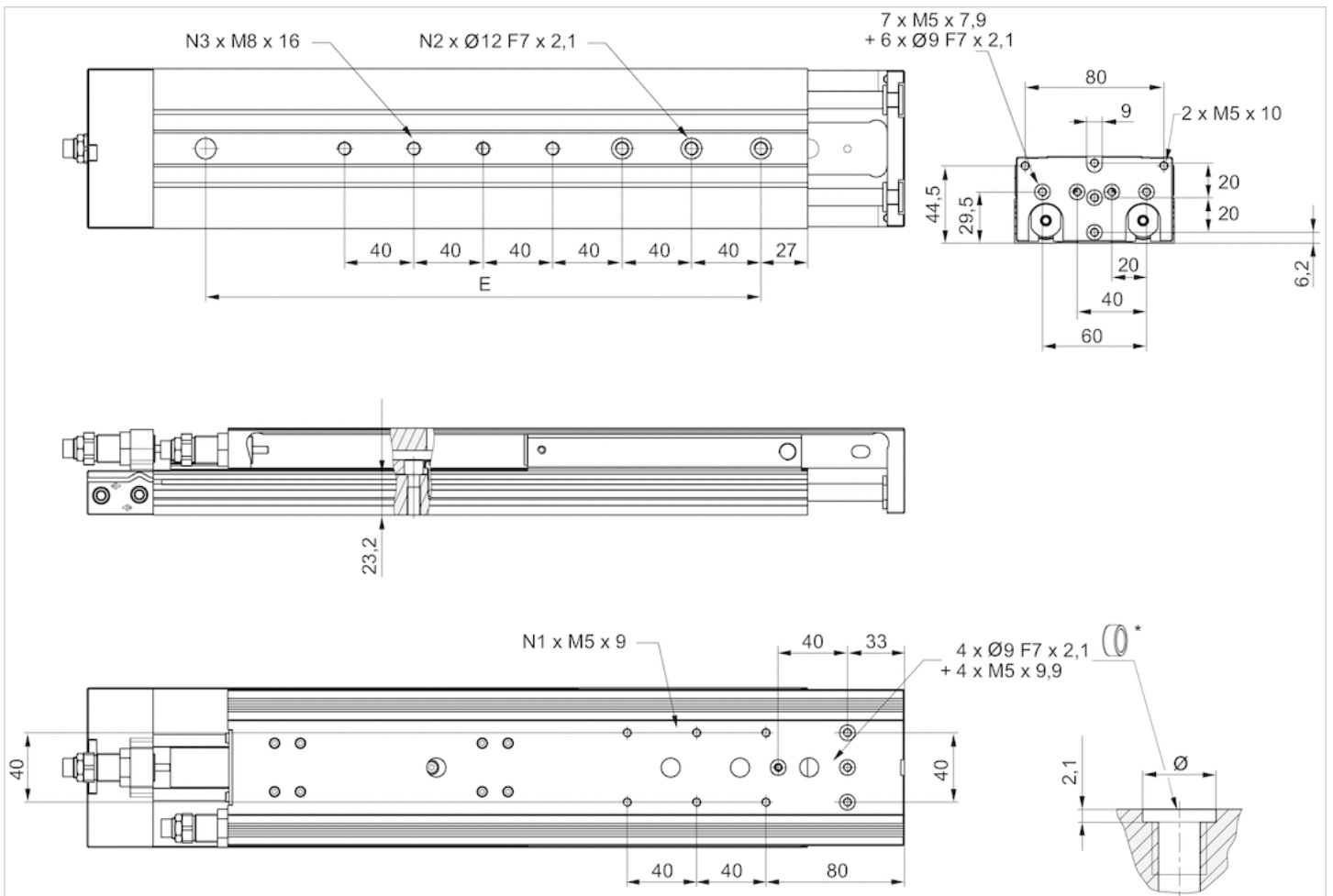

* = centering rings

Dimensions

Piston Ø	Stroke	N1	N2	N3
20 mm	30	2	2	2
20 mm	40	2	2	2
20 mm	50	2	2	2
20 mm	80	4	3	3
20 mm	100	4	3	3

Piston Ø	S=10	S=20	S=30	S=40	S=50	S=80	S=100	S=125	S=150	S=200
16 mm	0.375	0.375	0.375	0.4	0.45	0.615	0.65	0.725	0.765	–
20 mm	0.655	0.655	0.655	0.69	0.765	0.985	1.035	1.2	1.29	1.54
25 mm	1.1	1.1	1.1	1.1	1.225	1.45	1.625	1.885	2.085	2.445

Weight [kg]

Piston Ø	Stroke	Weight kg
8 mm	20	0.36 kg
8 mm	30	0.35 kg
8 mm	40	0.34 kg
8 mm	50	0.41 kg
8 mm	80	0.56 kg
12 mm	30	0.6 kg
12 mm	40	0.59 kg
12 mm	50	0.67 kg
12 mm	80	0.92 kg
12 mm	100	0.99 kg
16 mm	30	0.76 kg
16 mm	40	0.82 kg
16 mm	50	1.29 kg
16 mm	80	1.37 kg
16 mm	100	1.94 kg
20 mm	30	1.38 kg
20 mm	40	1.45 kg
20 mm	50	1.61 kg
20 mm	80	2.1 kg
20 mm	100	2.23 kg
25 mm	30	2.42 kg
25 mm	40	2.38 kg
25 mm	50	2.64 kg
25 mm	80	3.29 kg
25 mm	100	3.56 kg

Dimensions

Load capacity

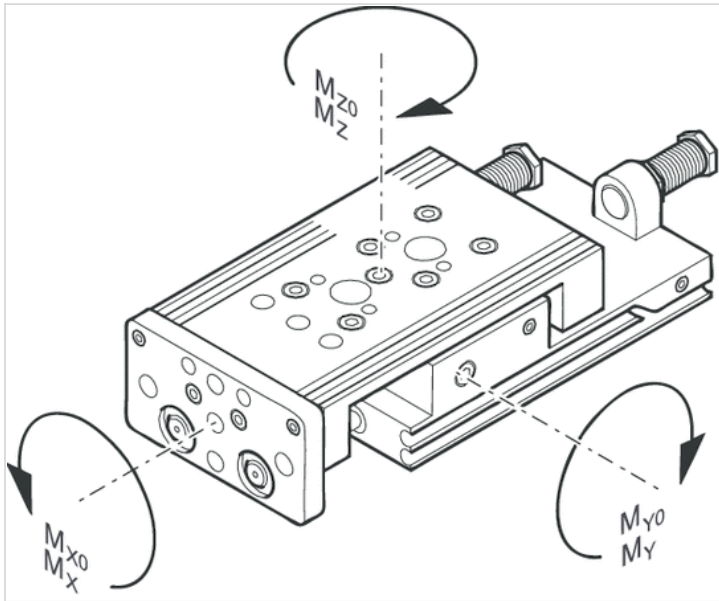

M = max. permissible torque

correction factor (a)

Piston Ø	Stroke	a [mm]	d [mm]	Mx0 Static moment M [Nm]
8 mm	20	69.5	12	5.8
8 mm	30	69.5	12	5.8
8 mm	40	69.5	12	5.8
8 mm	50	83	12	5.8
8 mm	80	121	12	8
12 mm	30	77	15	13.8
12 mm	40	77	15	13.8
12 mm	50	81	15	13.8
12 mm	80	117	15	17.3
12 mm	100	137	15	17.3
16 mm	30	65	15	31.6
16 mm	40	75	15	31.6
16 mm	50	86	15	31.6
16 mm	80	123	15	45
16 mm	100	144	15	45
20 mm	30	75	20	31.6
20 mm	40	75	20	31.6
20 mm	50	92	20	31.6
20 mm	80	125	20	45
20 mm	100	143	20	45
25 mm	30	85	24	87
25 mm	40	85	24	87
25 mm	50	102	24	87
25 mm	80	134	24	110

Piston Ø	Stroke	a [mm]	d [mm]	Mx0 Static moment M [Nm]
25 mm	100	152	24	110

My0 Static moment M [Nm]	Mz0 Static moment M [Nm]	Mx Dynamic moment M [Nm]
5.9	5.9	1.1
5.9	5.9	1.1
5.9	5.9	1.1
5.9	5.9	1.3
14.6	14.6	1.3
6.45	6.45	3.5
6.45	6.45	3.5
6.45	6.45	3.5
15.6	15.6	5.2
15.6	15.6	5.2
11.95	11.95	6.5
11.95	11.95	6.5
11.95	11.95	7
27.3	27.3	8.7
27.3	27.3	8.7
11.95	11.95	9.6
11.95	11.95	9.6
11.95	11.95	10
27.3	27.3	11.7
27.3	27.3	11.7
24.5	24.5	22.9
24.5	24.5	22.9
24.5	24.5	15.3
62.5	62.5	18.8
62.5	62.5	18.8

My Dynamic moment M [Nm]	Mz Dynamic moment M [Nm]
1.7	1.7
1.7	1.7
1.7	1.7
1.7	1.7
3.7	3.7
1.6	1.6
1.6	1.6
1.6	1.6
3.5	3.5
3.5	3.5
3.2	3.2
3.2	3.2
3.2	3.2
6.3	6.3
6.3	6.3
4	4
4	4
4	4
8	8

My Dynamic moment M [Nm]	Mz Dynamic moment M [Nm]
8	8
6.6	6.6
6.6	6.6
6.6	6.6
14.5	14.6
14.5	14.6

Dimensions

correction factor (a, d)

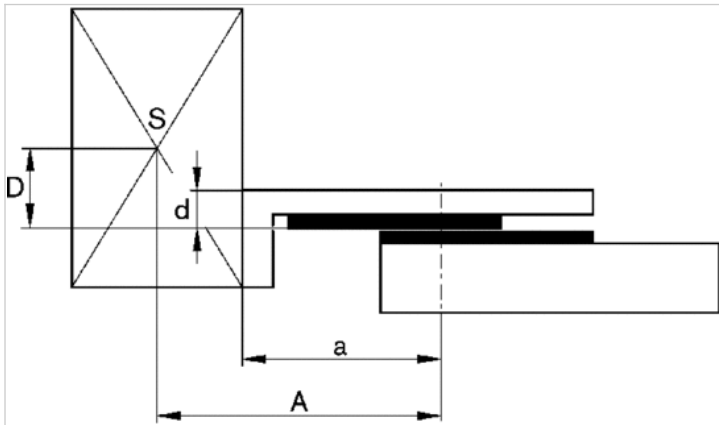

horizontal

stat.	$M_{B0} = F_G \cdot A + F \cdot D$
dyn.	$M_B = F_G \cdot A$

stat.	$M_{C0} = F_G \cdot B$
dyn.	$M_C = F_G \cdot B$

stat.	$M_{A0} = F \cdot B$
dyn.	$M_A = 0$

dyn.	$\frac{M_A}{M_1} + \frac{M_B}{M_2} + \frac{M_C}{M_3} \leq 1$
stat.	$\frac{M_{A0}}{M_{Z0}} + \frac{M_{B0}}{M_{Y0}} + \frac{M_{C0}}{M_{X0}} \leq 1$

$F = m \cdot a$
 $FG = m \cdot g$
 $a = 1250 \cdot V^2 / H$

F = deceleration force [N]
 FG = force due to weight [N]
 m = load mass [kg]
 a = deceleration [m/s²]
 g = gravitational acceleration 9,81 [m/s²]

V = velocity [m/s]

H = stroke length of shock absorber [mm]

vertical

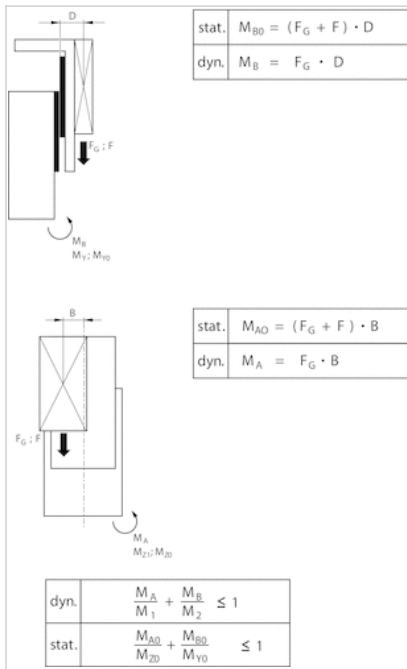

$$F = m \cdot a$$

$$F_G = m \cdot g$$

$$a = 1250 \cdot V^2 / H$$

F = deceleration force [N]

F_G = force due to weight [N]

m = load mass [kg]

a = deceleration [m/s²]

g = gravitational acceleration 9,81 [m/s²]

V = velocity [m/s]

H = stroke length of shock absorber [mm]

Diagrams

Minimum and maximum moving mass

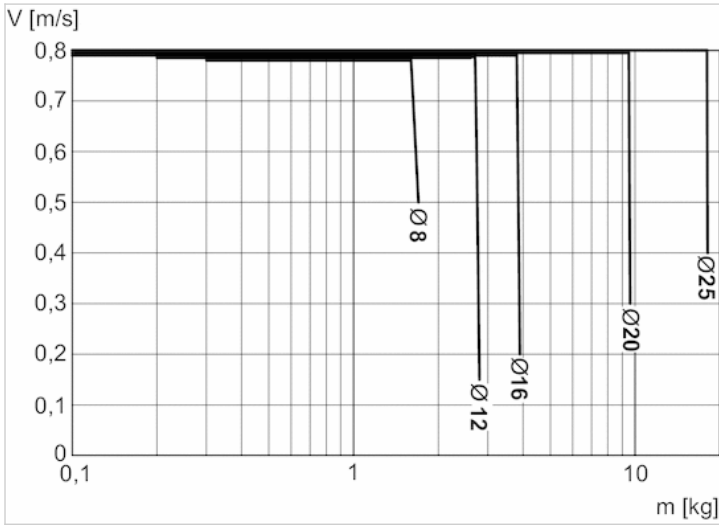

V = velocity [m/s]
 m = mass

Correction factor for required speed: retracting and extending, horizontal

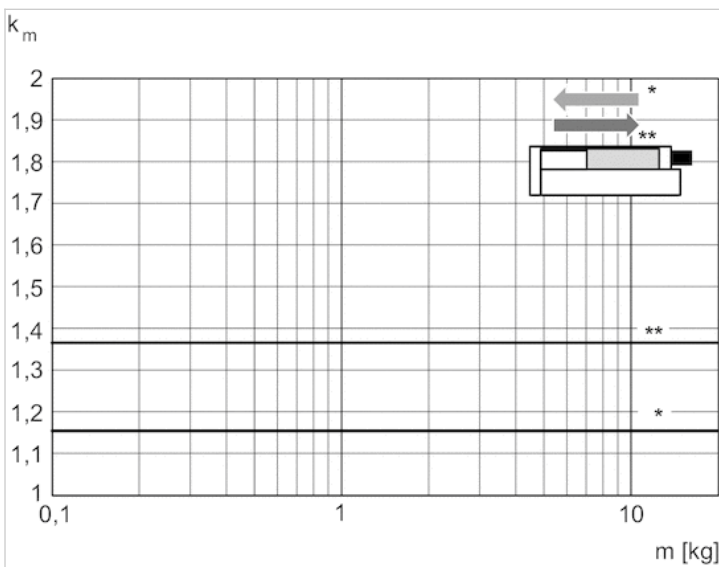

* retracting
 ** extracting
 $V = s/1000 \cdot t \cdot k_m$
 V = velocity [m/s]
 S = stroke

Max. additional moving mass, horizontal

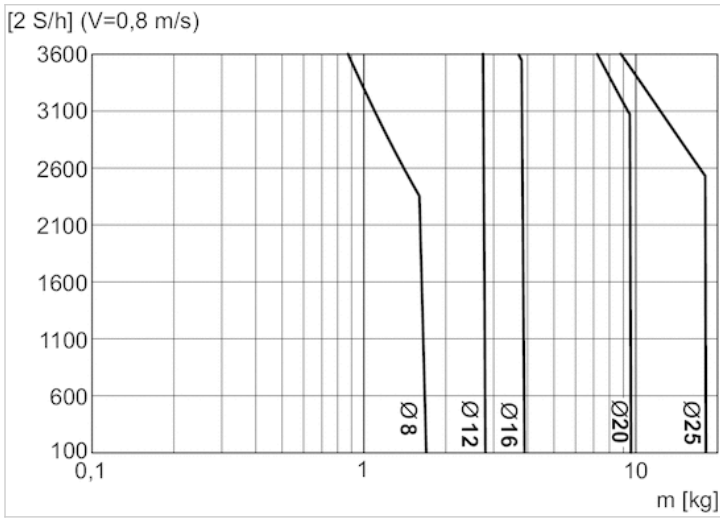

S = stroke [mm]
 2 x S = 1 cycle
 V = velocity [m/s]
 m = mass

Max. additional moving mass, vertical

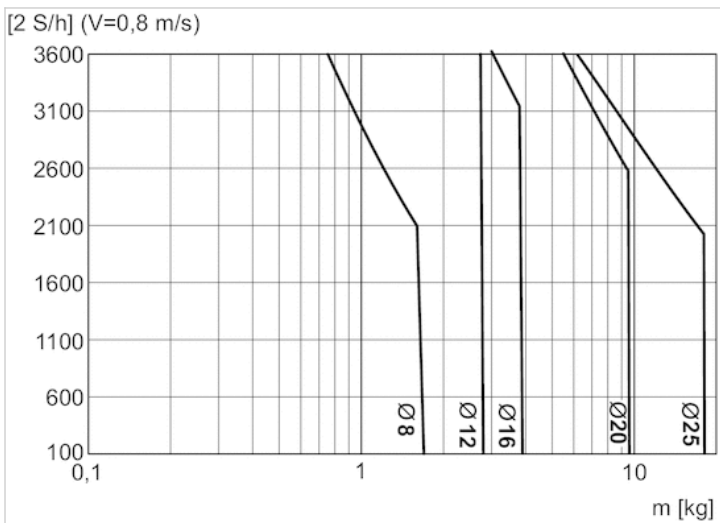

S = stroke [mm]
 2 x S = 1 cycle
 V = velocity [m/s]
 m = mass

Correction factor for required speed: extending, vertical, upwards

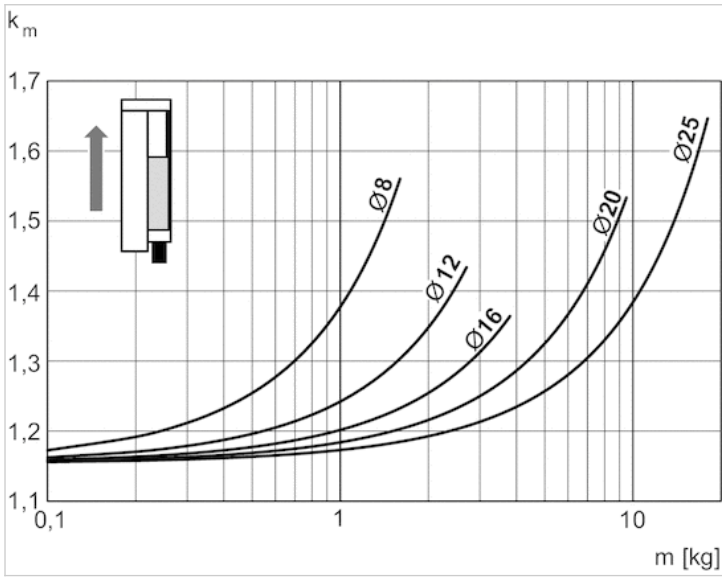

$V = s/1000 \cdot t \cdot k_m$
 $V = \text{velocity [m/s]}$
 $S = \text{stroke [mm]}$
 $t = \text{time [s] for one stroke}$
 $m = \text{mass}$

Correction factor for required speed: retracting, vertical, upwards

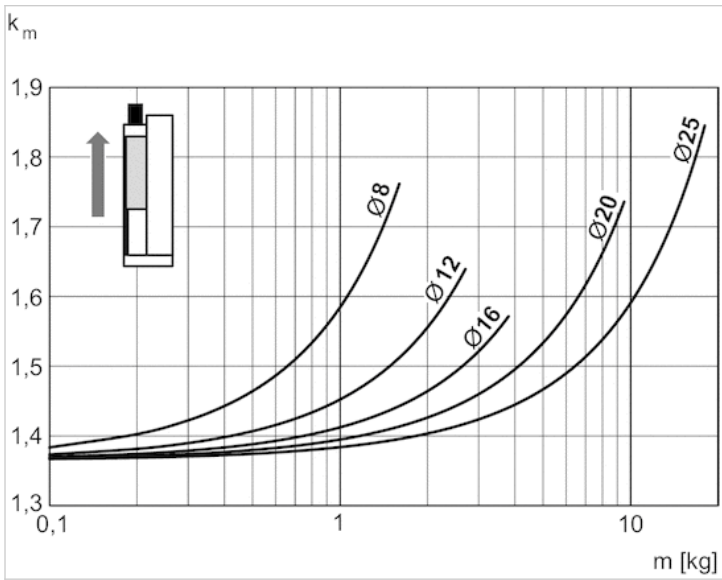

$V = s/1000 \cdot t \cdot k_m$
 $V = \text{velocity [m/s]}$
 $S = \text{stroke [mm]}$
 $t = \text{time [s] for one stroke}$
 $m = \text{mass}$

Correction factor for required speed: retracting, vertical, downwards

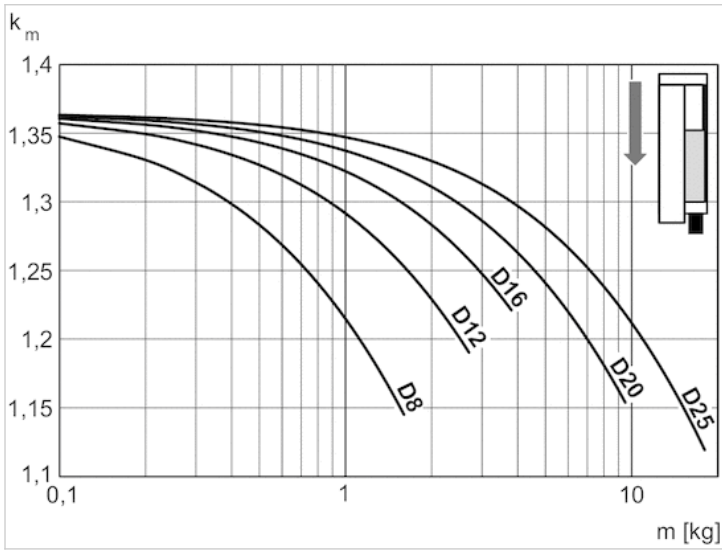

$V = s/1000 \cdot t \cdot k_m$
 $V =$ velocity [m/s]
 $S =$ stroke [mm]
 $t =$ time [s] for one stroke
 $m =$ mass

Correction factor for required speed: extending, vertical, downwards

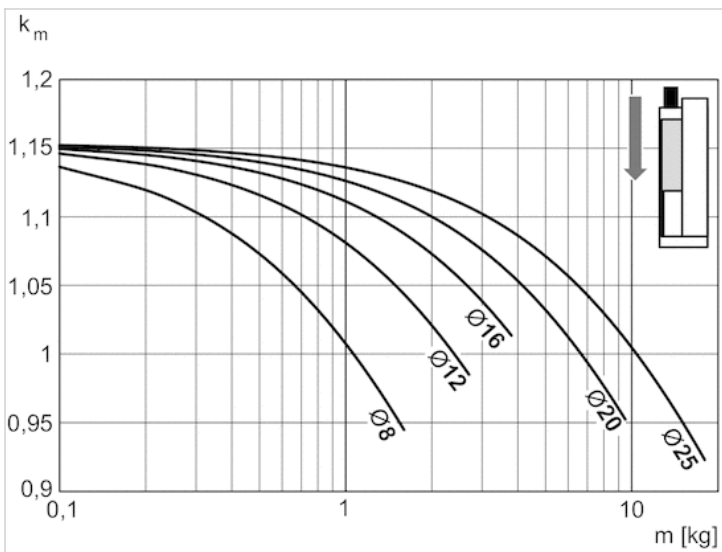

$V = s/1000 \cdot t \cdot k_m$
 $V =$ velocity [m/s]
 $S =$ stroke [mm]
 $t =$ time [s] for one stroke
 $m =$ mass

Extracting speed max.

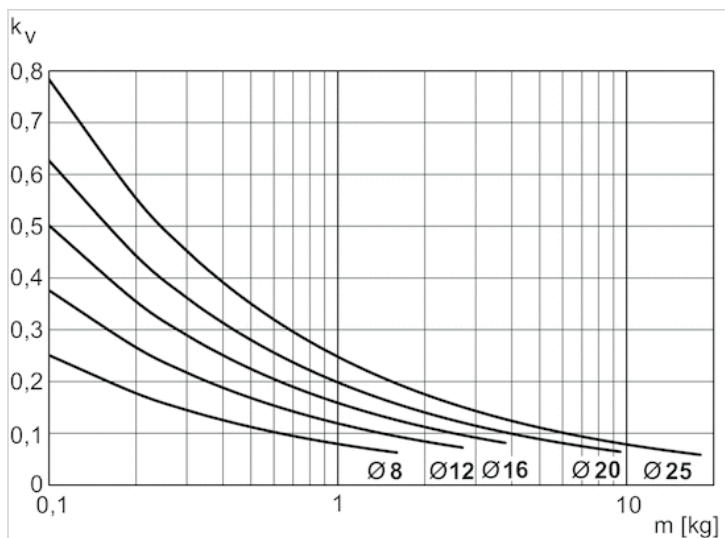

$V = \sqrt{s \cdot kv}$

V = velocity [m/s]

S = stroke [mm]

m = mass

Accessories overview

Overview drawing

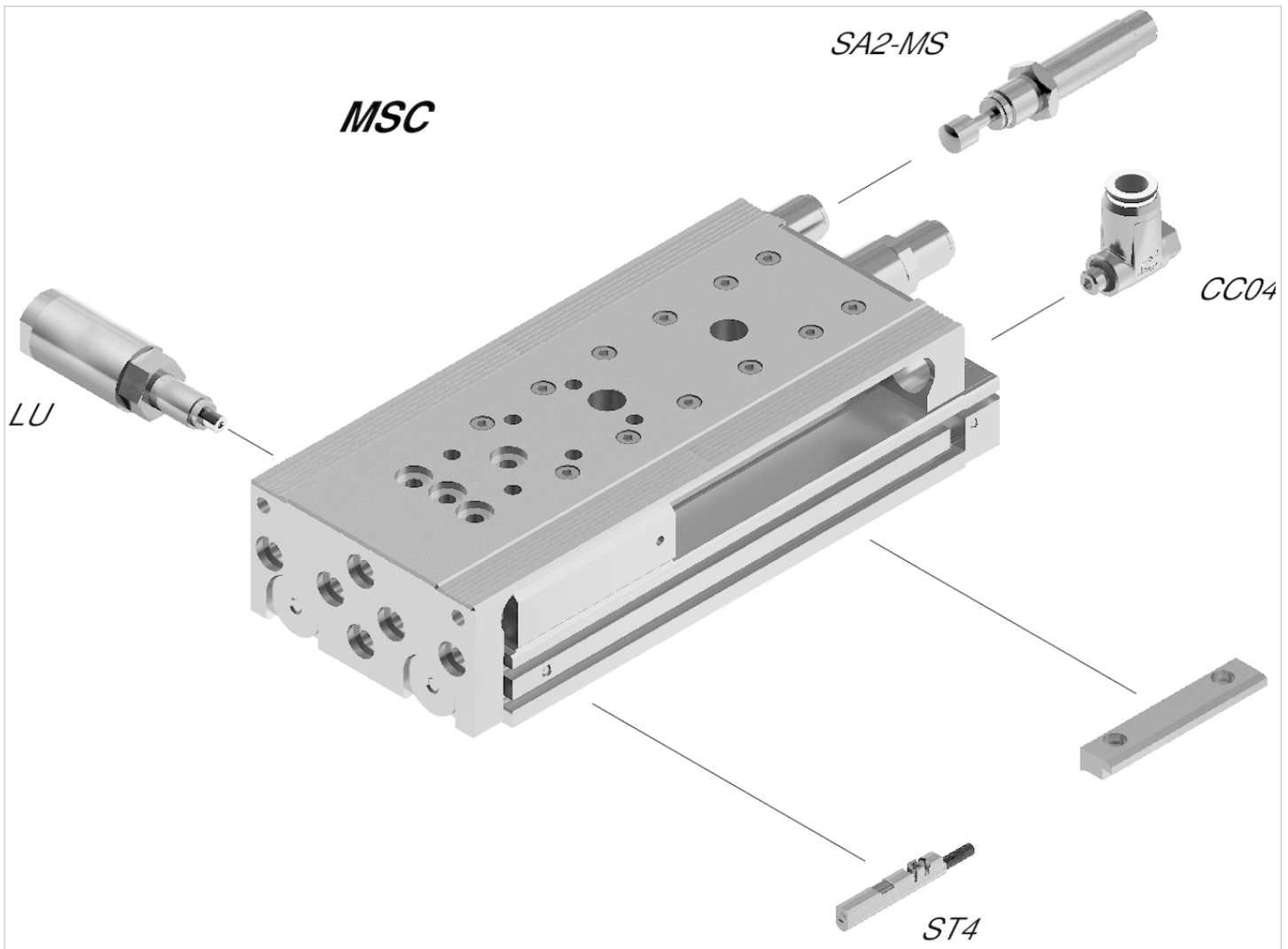

NOTE:

This overview drawing is only for orientation to indicate where the various accessory parts can be fastened to the cylinder. The illustration has been simplified for this purpose. It is thus not possible to derive the dimensions from this overview.

Mini slide, Series MSC

- Scope of delivery: incl. centering rings
- Ø 8-25 mm
- double-acting
- Single piston

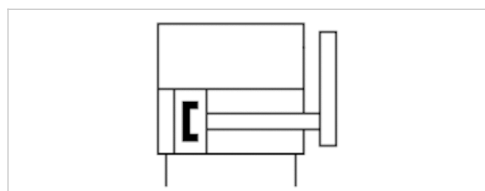

Working pressure min./max.	See table below
Ambient temperature min./max.	0 ... 60 °C
Medium	Compressed air
Max. particle size	5 µm
Oil content of compressed air	0 ... 1 mg/m ³
Repetitive precision	0,3 mm

Technical data

Piston Ø 2x	8 mm	12 mm	16 mm	20 mm
Working pressure min./max.	2 ... 10 bar	1.5 ... 10 bar	1 ... 10 bar	1 ... 10 bar
Retracting piston force, theoretical	24 N	53 N	109 N	148 N
Extracting piston force, theoretical	32 N	71 N	127 N	198 N
Speed max.	0.8 m/s	0.8 m/s	0.8 m/s	0.8 m/s

Piston Ø 2x	25 mm
Working pressure min./max.	1 ... 10 bar
Retracting piston force, theoretical	260 N
Extracting piston force, theoretical	309 N
Speed max.	0.8 m/s

Technical information

The pressure dew point must be at least 15 °C under ambient and medium temperature and may not exceed 3 °C .

The oil content of compressed air must remain constant during the life cycle.

Use only the approved oils from AVENTICS. Further information can be found in the "Technical information" document (available in the MediaCentre).

Technical information

Material	
Housing	Aluminum, anodized
Piston rod	Stainless steel
Front plate	Aluminum, anodized
Seal	Polyurethane
Ball rail table	Aluminum, anodized
Guide rail	Steel, hardened
Centering rings	Stainless steel

Diagrams

Correction factor for required speed: extending, vertical, upwards

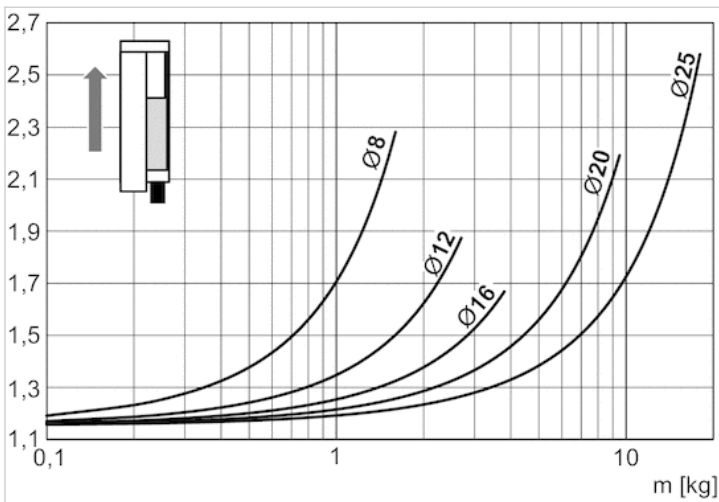

$$V = s/1000 \cdot t \cdot km$$

V = velocity [m/s]

S = stroke [mm]

Correction factor for required speed: retracting, vertical, upwards

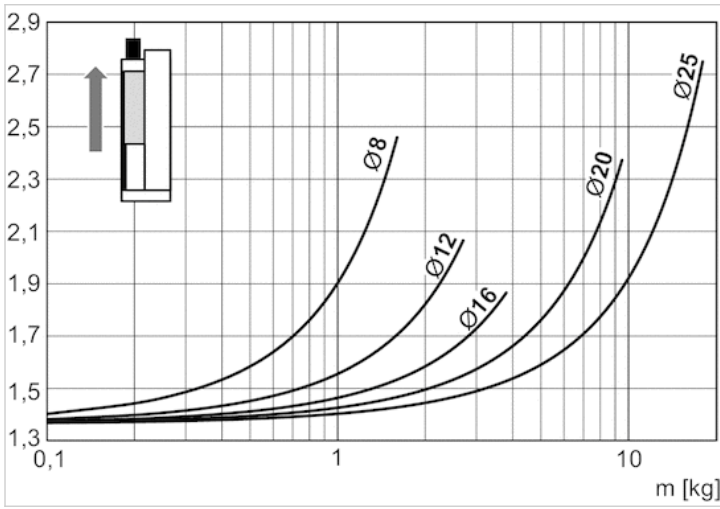

$V = s/1000 \cdot t \cdot km$
 V = velocity [m/s]
 S = stroke [mm]

Correction factor for required speed: retracting, vertical, downwards

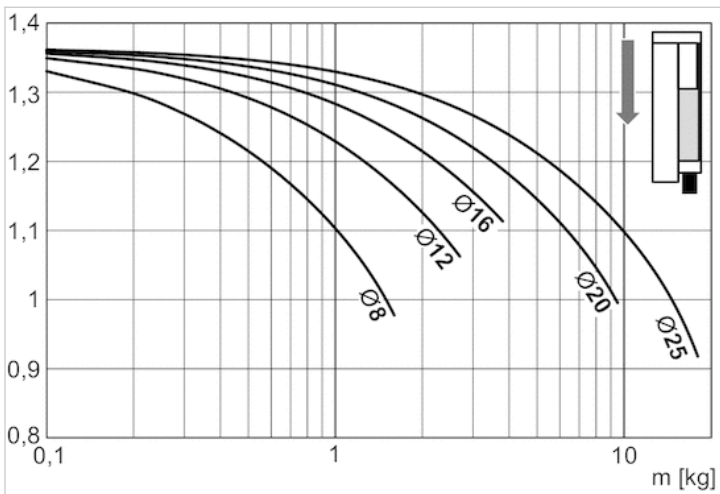

$V = s/1000 \cdot t \cdot km$
 V = velocity [m/s]
 S = stroke [mm]

Correction factor for required speed: extending, vertical, downwards

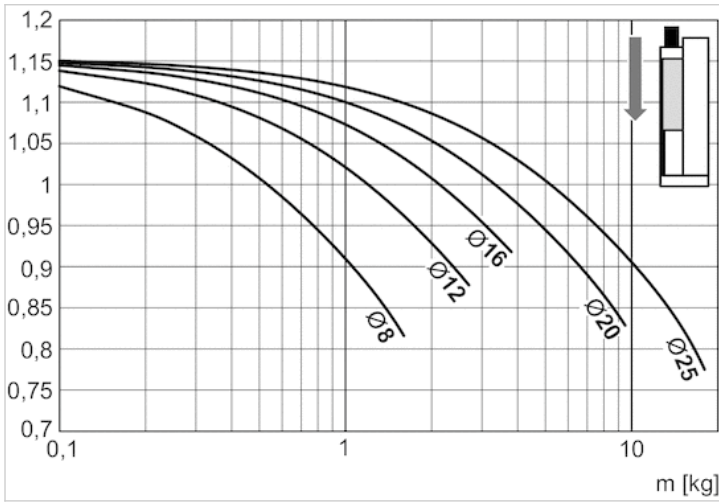

$V = s/1000 \cdot t \cdot km$
 V = velocity [m/s]
 S = stroke [mm]

Extracting speed max.

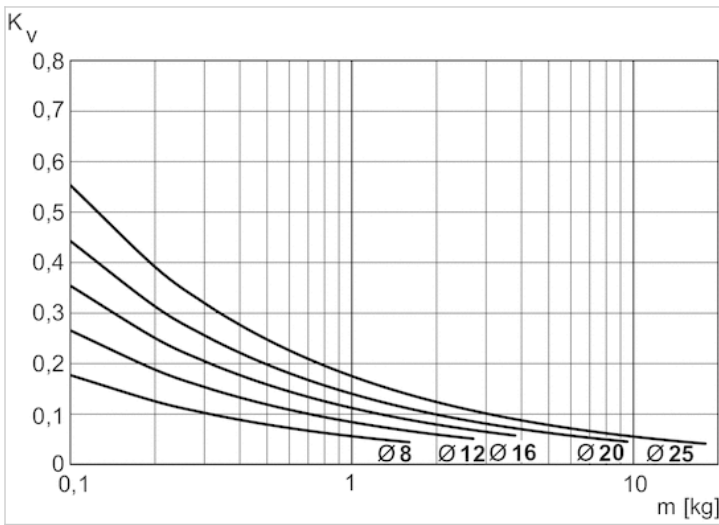

$V = \sqrt{s \cdot kv}$
 V = velocity [m/s]
 S = stroke [mm]
 m = mass

Accessories overview

Overview drawing

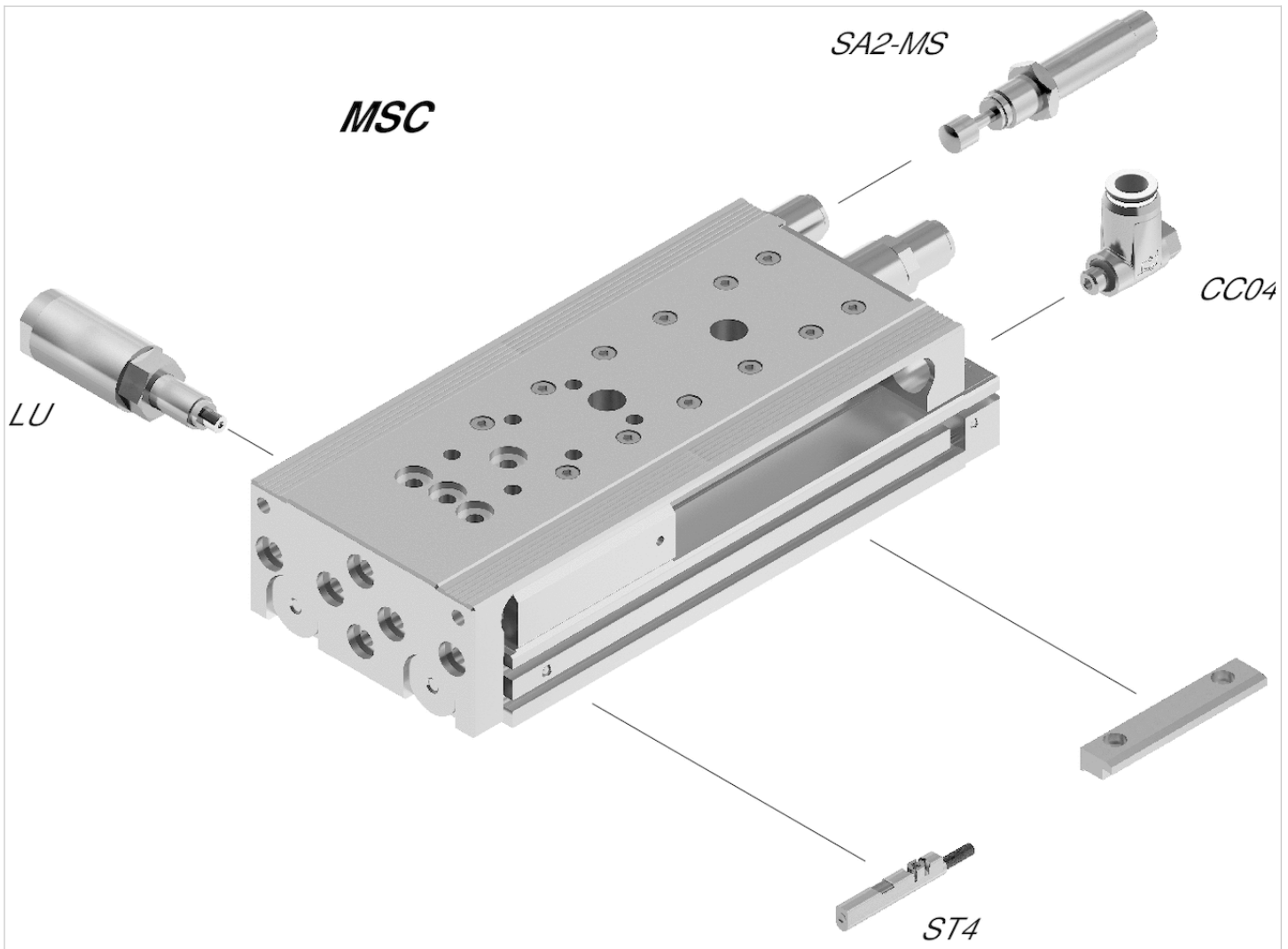

NOTE:

This overview drawing is only for orientation to indicate where the various accessory parts can be fastened to the cylinder. The illustration has been simplified for this purpose. It is thus not possible to derive the dimensions from this overview.

Centering rings



Technical data

Part No.	External Ø	Scope of delivery	Fig.
R412000669	5-5 mm	6 piece	Fig. 1
R412000668	7 mm	6 piece	Fig. 1
R412000670	9 mm	6 piece	Fig. 1
R412000671	12 mm	6 piece	Fig. 1
R402003731	16 mm	6 piece	Fig. 1
R412004030	7-5 mm	6 piece	Fig. 2
R412004032	9-5 mm	6 piece	Fig. 2
R412004033	9-7 mm	6 piece	Fig. 2
R412004034	12-9 mm	6 piece	Fig. 2
R402003736	16-12 mm	6 piece	Fig. 2

Technical information

Material	
Housing	Stainless steel

Dimensions

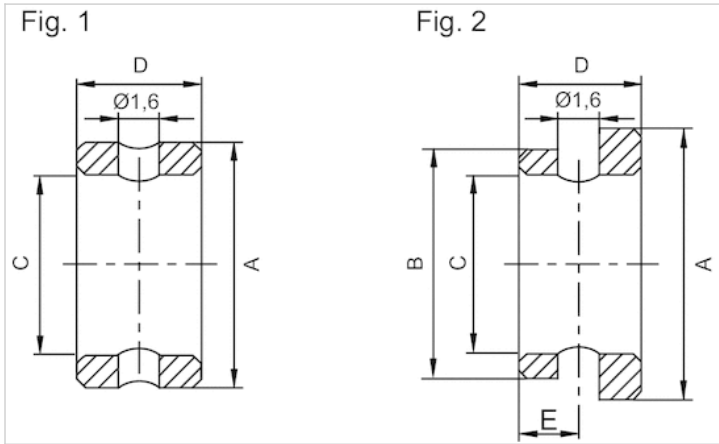

Dimensions

Part No.	Ø	A k6	B k6	C ±0,1	D -0,2	E +0,2	Fig.
R412000669	5	5	–	3,4	3	–	Fig. 1
R412000668	7	7	–	5,5	3	–	Fig. 1
R412000670	9	9	–	6,6	4	–	Fig. 1
R412000671	12	12	–	9,0	4	–	Fig. 1
R402003731	16	16	–	11	6	–	Fig. 1
R412004030	5-7	7	5	3,4	3	1,5	Fig. 2
R412004032	5-9	9	5	3,4	3,5	1,5	Fig. 2
R412004033	7-9	9	7	5,5	3,5	1,5	Fig. 2
R412004034	9-12	12	9	6,6	4,0	2	Fig. 2
R402003736	12-16	16	12	9	5	2	Fig. 2

Clamping fixtures

- for series CKP-16, MSC-20 CKP-25, CKP-32, MSC-25



Technical data

Part No.
R037531000
R037531032
R037531033
R037531026
R037541026
R037551000
R037551033
R037551034

Technical information

Material	
Material	Aluminum

Dimensions

Clamping fixtures

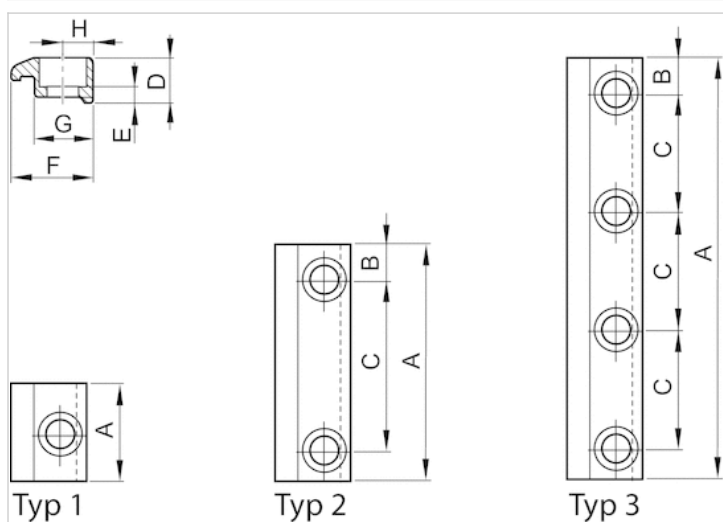

Dimensions

Part No.	1)	Typ	A	B	C	D	E	F	G	H
R037531000	M4	1	25	-	-	9	4.6	14.5	10.5	5
R037531032	M4	2	72	11	50	9	4.6	14.5	10.5	5
R037531033	M4	2	62	11	40	9	4.6	14.5	10.5	5
R037531026	M4	3	77	8.5	20	9	4.6	14.5	10.5	5
R037541026	M5	3	77	8.5	20	11.5	4.8	19.3	14	7
R037551000	M6	1	25	-	-	11.5	5.3	19.3	14	7
R037551033	M6	2	72	11	50	11.5	5.3	19.3	14	7
R037551034	M6	2	62	11	40	11.5	5.3	19.3	14	7

1) countersink for screw

Check-choke valve, Series CC04

- $Q_n 2 \rightarrow 1 = 70\text{--}470 \text{ l/min}$
- direction of throttle $2 \rightarrow 1$
- exhaust air throttling
- push-in fitting / External thread



Working pressure min./max.	0.5 ... 10 bar
Ambient temperature min./max.	-10 ... 60 °C
Medium temperature min./max.	-10 ... 60 °C
Medium	Compressed air

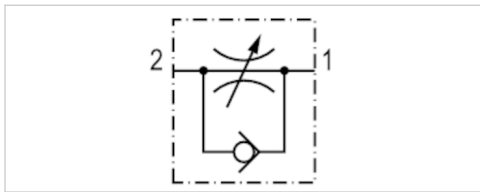

Technical data

Part No.	Port 1	Port 2	Throttle bore	Flow	Fig.
			Ø	$Q_n 2 \rightarrow 1$	
R412010564	Ø 4	M5	2 mm	70 l/min	Fig. 1
R412010565	Ø 6	M5	2 mm	110 l/min	Fig. 1
R412010568	Ø 4	G 1/8	3.5 mm	150 l/min	Fig. 2
R412010569	Ø 6	G 1/8	3.5 mm	390 l/min	Fig. 2
R412010570	Ø 8	G 1/8	3.5 mm	470 l/min	Fig. 2

Nominal flow Q_n at 6 bar and $\Delta p = 1$ bar

Technical information

Material	
Housing	Polyamide
Seals	Acrylonitrile butadiene rubber
Port	Brass, nickel-plated

Dimensions

Dimensions

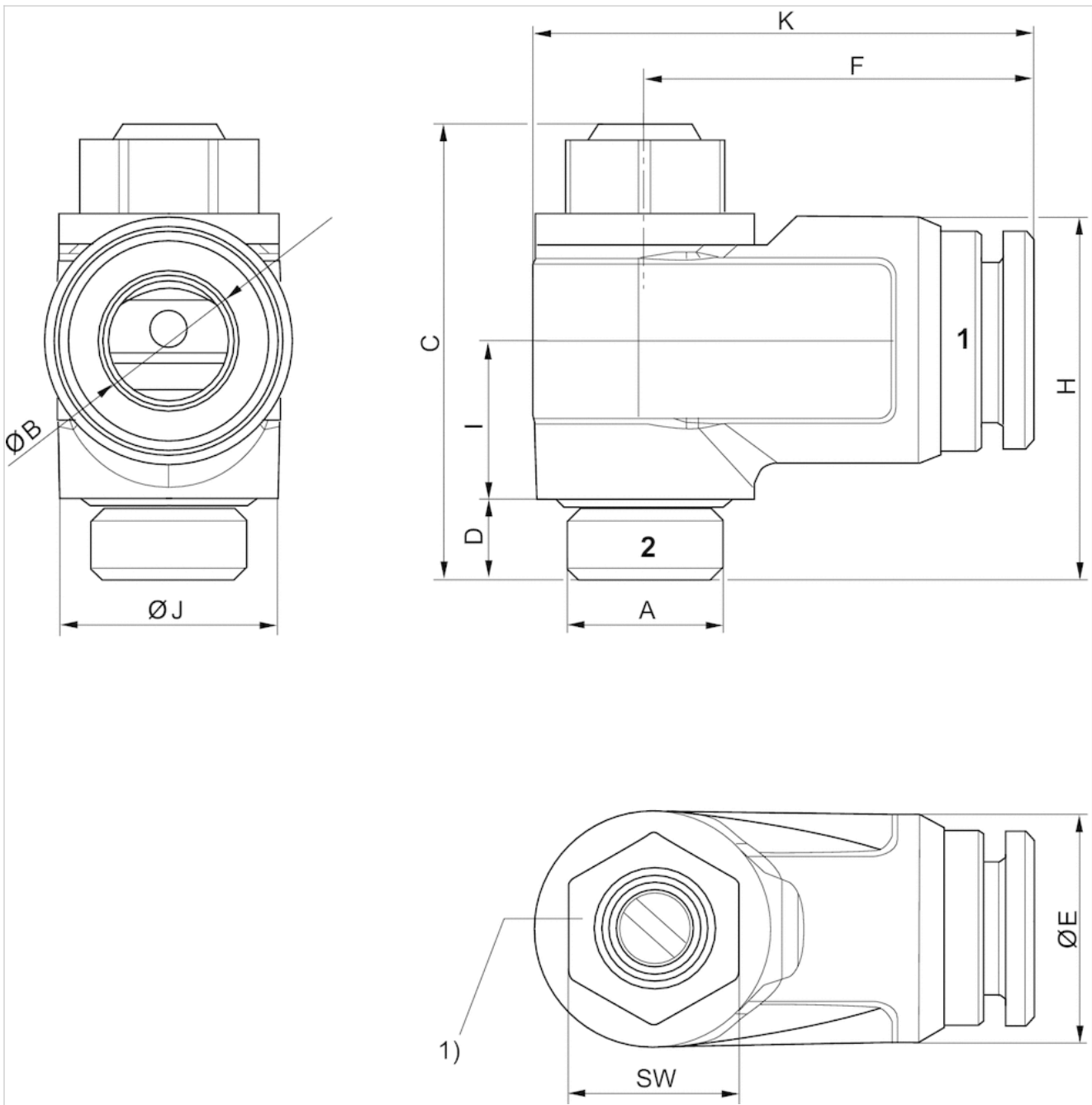

1) Recommended tightening torque MA:

- M 5: 1.1 Nm -0.2
- G 1/8: 3.0 Nm -0.3
- G 1/4: 6.0 Nm -0.6
- G 3/8: 8.0 Nm -1.0
- G 1/2: 10.0 Nm -1.0

Dimensions

Part No.	Port 1	Port 2	Ø B	C	D	Ø E	F	K	H	I	Ø J	SW
R412010564	Ø 4	M5	4	21.8	4	9	15.9	20.4	12	7.5	8.7	7
R412010565	Ø 6	M5	6	21.8	4	11.1	17.2	21.8	13	7.5	8.7	7

Part No.	Port 1	Port 2	Ø B	C	D	Ø E	F	K	H	I	Ø J	SW
R412010568	Ø 4	G 1/8	4	28.5	5.5	11.5	21.9	28.8	21	9.8	13.6	10
R412010569	Ø 6	G 1/8	6	28.5	5.5	13.5	22.4	29.3	21.7	9.8	13.6	10
R412010570	Ø 8	G 1/8	8	28.5	5.5	15.5	24.2	31.1	22.7	9.8	13.6	10

Diagrams

Flow diagram, Fig. 1

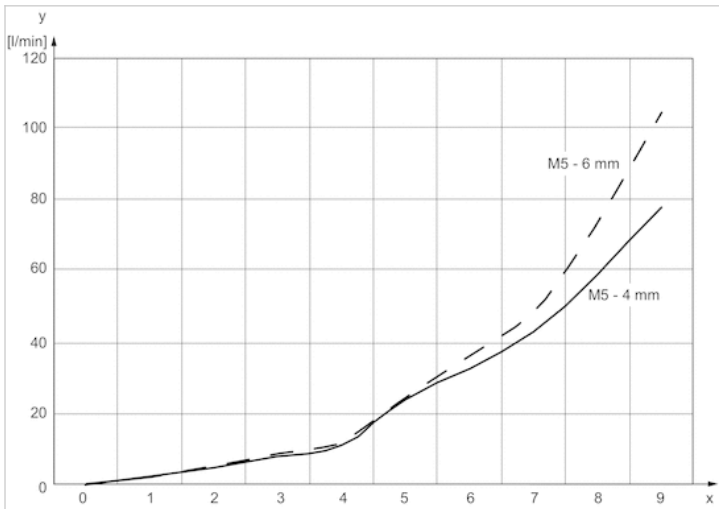

x = rotations of the throttle screw
y = flow rate Qn

Flow diagram, Fig. 2

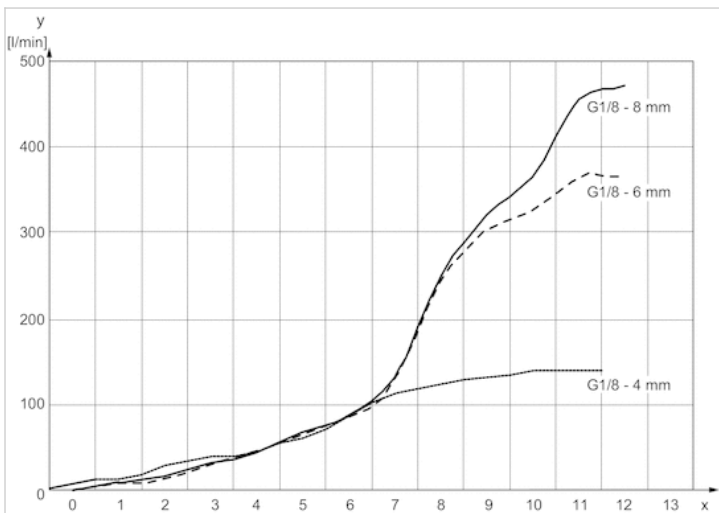

x = rotations of the throttle screw
y = flow rate Qn

Flow diagram, Fig. 3

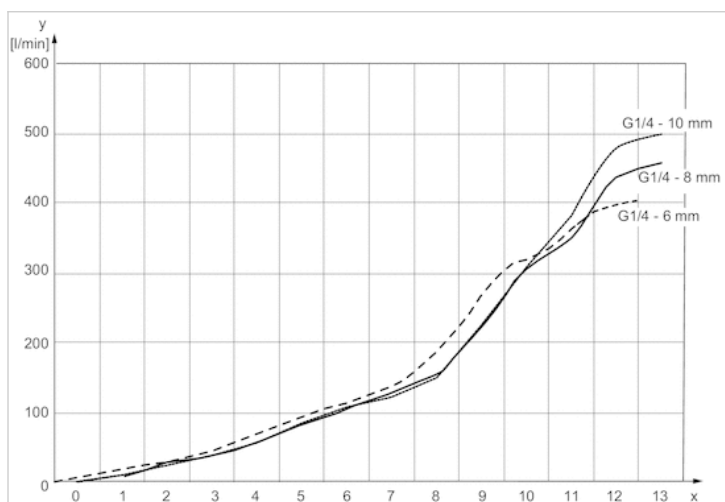

x = rotations of the throttle screw
 y = flow rate Qn

Flow diagram, Fig. 4

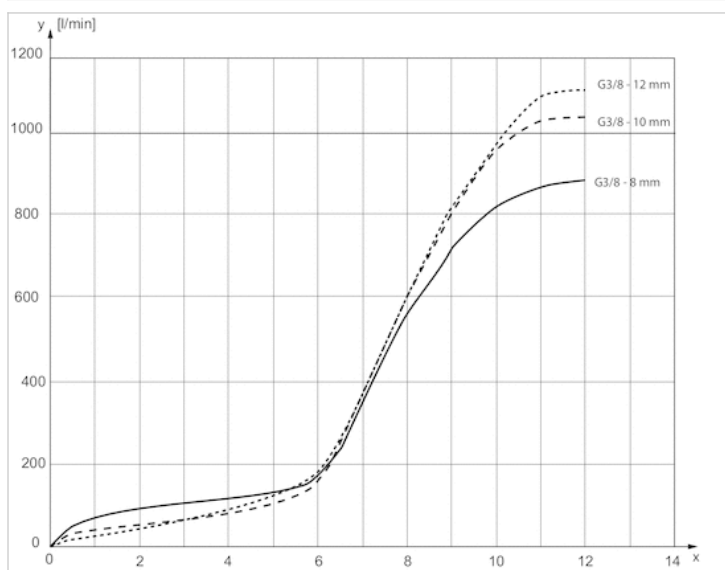

x = rotations of the throttle screw
 y = flow rate Qn

Flow diagram, Fig. 5

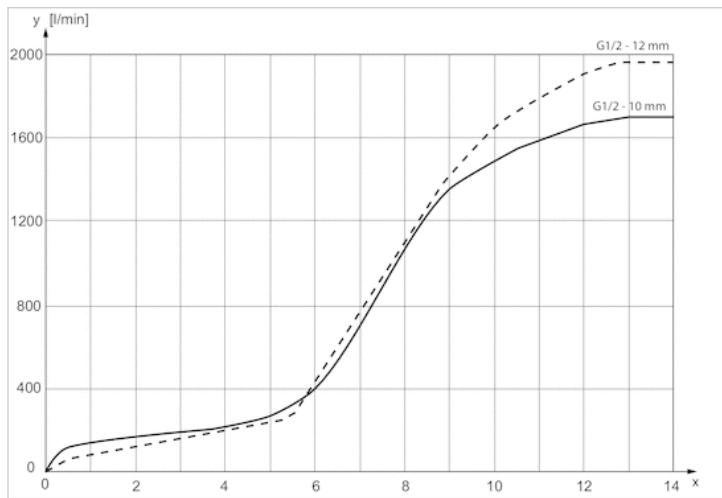

x = rotations of the throttle screw
y = flow rate Q_n

stroke setting accessories



Technical data

Part No.	Type
R422100795	MSC-08-HM
R422100797	MSC-12-HM
R422100799	MSC-20-HM
R422100801	MSC-25-HM
R422100796	MSC-08-EE
R422100798	MSC-12-EE
R422100800	MSC-20-EE
R422100802	MSC-25-EE
R412021913	MSC-08-EM
R412021914	MSC-12-EM
R412021915	MSC-20-EM
R412021916	MSC-25-EM
R412021836	MSC-08
7472D00616	MSC-08
7472D00626	MSC-08
R412022650	MSC-12 / 16
7472D00620	MSC-12 / 16
7472D00619	MSC-12 / 16
7472D00623	MSC-20 / 25
7472D00622	MSC-20 / 25
7472D00625	MSC-20 / 25

Dimensions

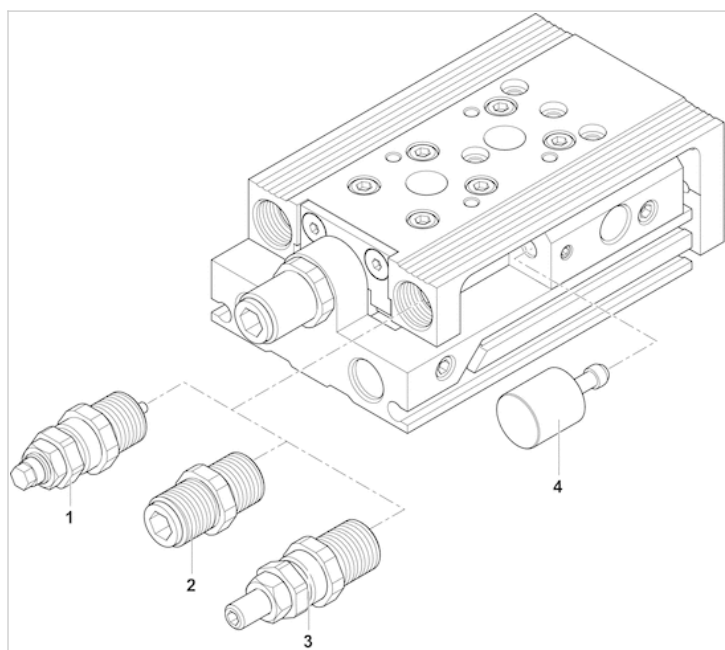

Dimensions

Part No.	Type	1)	3)	Ø8	Ø12	Ø16	Ø20	Ø25
R422100795	MSC-08-HM	1	-	MSC-HM	-	-	-	-
R422100797	MSC-12-HM	1	-	-	MSC-HM	MSC-HM	-	-
R422100799	MSC-20-HM	1	-	-	-	-	MSC-HM	-
R422100801	MSC-25-HM	1	-	-	-	-	-	MSC-HM
R422100796	MSC-08-EE	2	-	MSC-EE	-	-	-	-
R422100798	MSC-12-EE	2	-	-	MSC-EE	MSC-EE	-	-
R422100800	MSC-20-EE	2	-	-	-	-	MSC-EE	-
R422100802	MSC-25-EE	2	-	-	-	-	-	MSC-EE
R412021913	MSC-08-EM	3	-	MSC-EM	-	-	-	-
R412021914	MSC-12-EM	3	-	-	MSC-EM	MSC-EM	-	-
R412021915	MSC-20-EM	3	-	-	-	-	MSC-EM	-
R412021916	MSC-25-EM	3	-	-	-	-	-	MSC-EM
R412021836	MSC-08	4	30	-	-	-	-	-
7472D00616	MSC-08	4	10	-	-	-	-	-
7472D00626	MSC-08	4	20	-	-	-	-	-
R412022650	MSC-12 / 16	4	30	-	-	-	-	-
7472D00620	MSC-12 / 16	4	10	-	-	-	-	-
7472D00619	MSC-12 / 16	4	20	-	-	-	-	-
7472D00623	MSC-20 / 25	4	10	-	-	-	-	-
7472D00622	MSC-20 / 25	4	20	-	-	-	-	-
7472D00625	MSC-20 / 25	4	30	-	-	-	-	-

1) Single parts

2) Stroke

3) Additional stroke limitation in mm

Industrial shock absorber, Series SA1-MC

- Cushioning self-compensating
- Mounting Lock nut
- Mounting thread M6x0,5
- SA1-MC



Ambient temperature min./max.	-20 ... 80 °C
Medium	Oil
Mounting	Lock nut
Mounting thread	M6x0,5
Weight	0.003 kg

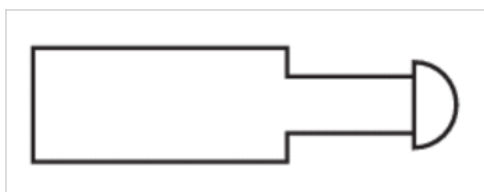

Technical data

Part No.	Mounting thread	Stroke	Max. energy absorption/stroke	Max. energy absorption/hour
R412010284	M6x0,5	5 mm	1 Nm	3000 Nm

Part No.	Effective mass me	Return spring force	Fig.
	min./max.	min./max.	
R412010284	0.8 ... 2.8 kg	2 ... 5 N	Fig. 1

Technical information

Material	
Cylinder tube	Steel, salt bath nitrocarburized
Piston rod	Stainless steel, ground and hardened
sealing for piston rod	Polyurethane
Lock nut	Steel, salt bath nitrocarburized
Mounting ring	Polyoxymethylene

Dimensions

Fig. 1

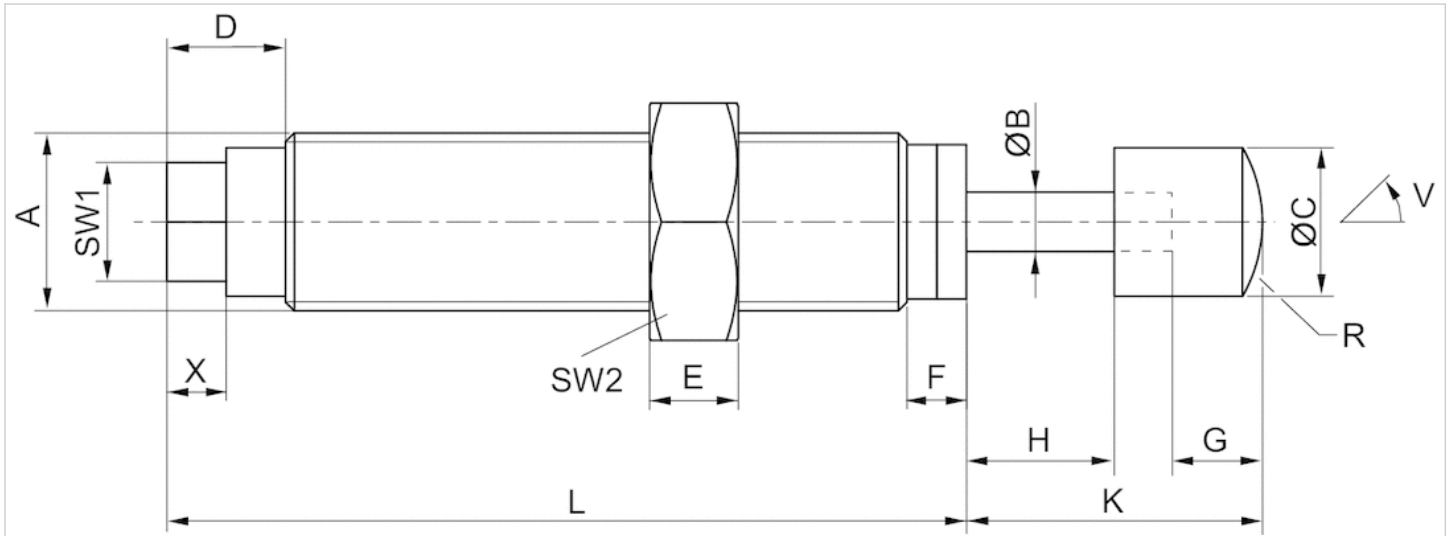

A = mounting thread
V = tilt

Dimensions

Part No.	Type	Mounting thread	ØB	ØC	D	E	F	G	H	K	L	R	SW1	SW2	W [°]	X
R412010284	SA1-MC	M6x0,5	2	5	4	3	2	2	5	10	27	5	4	8	2	2

Dimensions

Fig. 2

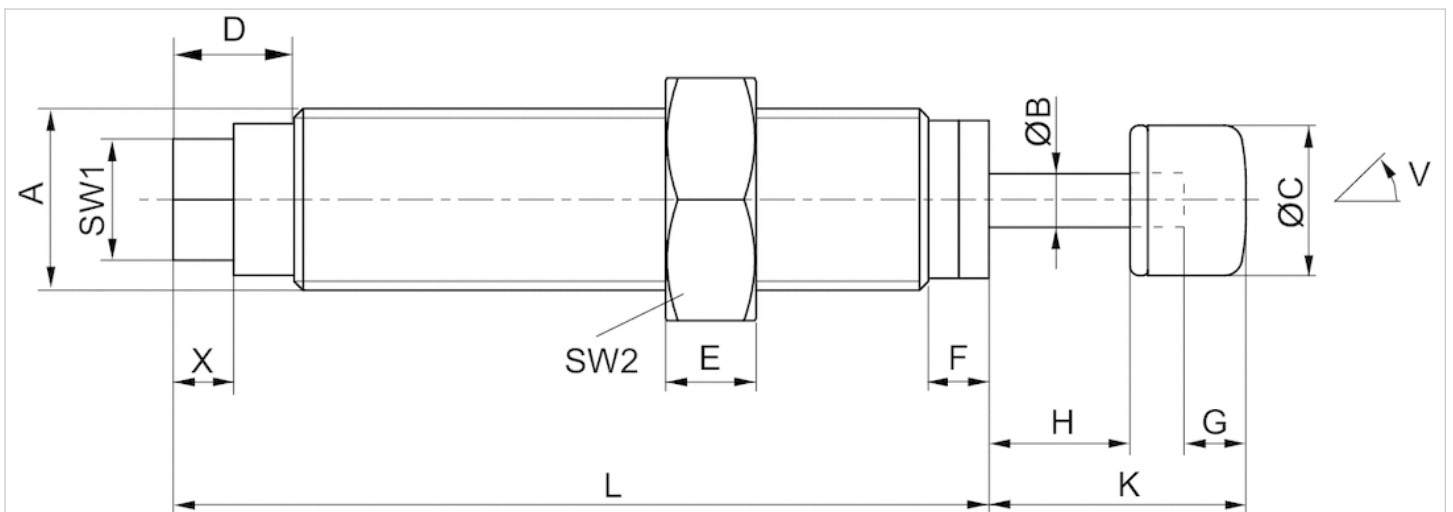

A = mounting thread
V = tilt

Dimensions

Type	Mounting thread
SA1-MC	M6x0,5

Dimensions

Fig. 3

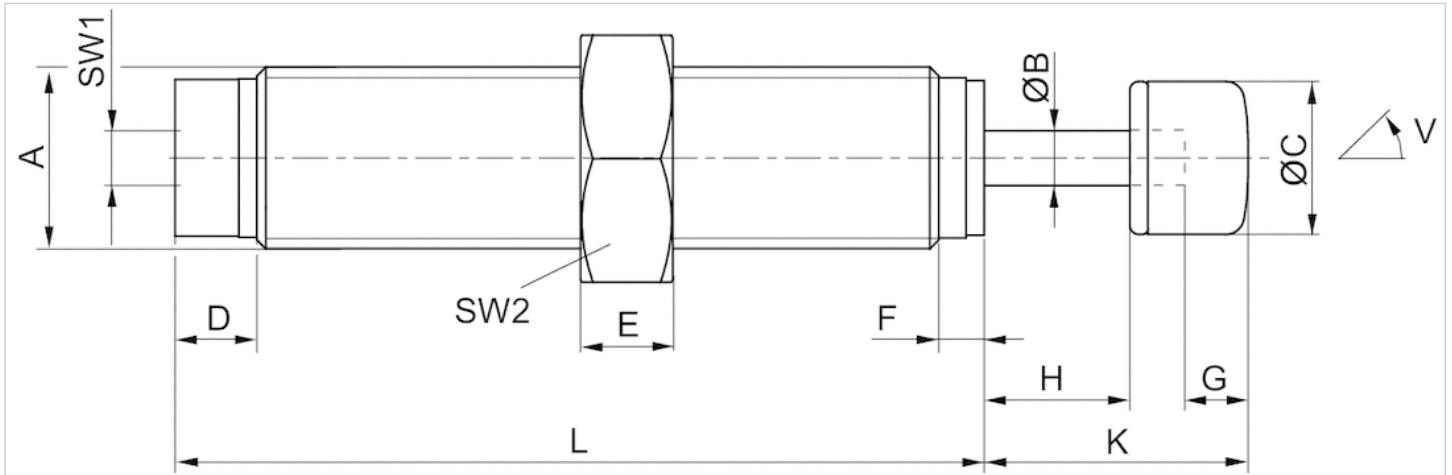

A = mounting thread
V = tilt

Dimensions

Type	Mounting thread
SA1-MC	M6x0,5

Dimensions

Fig. 4

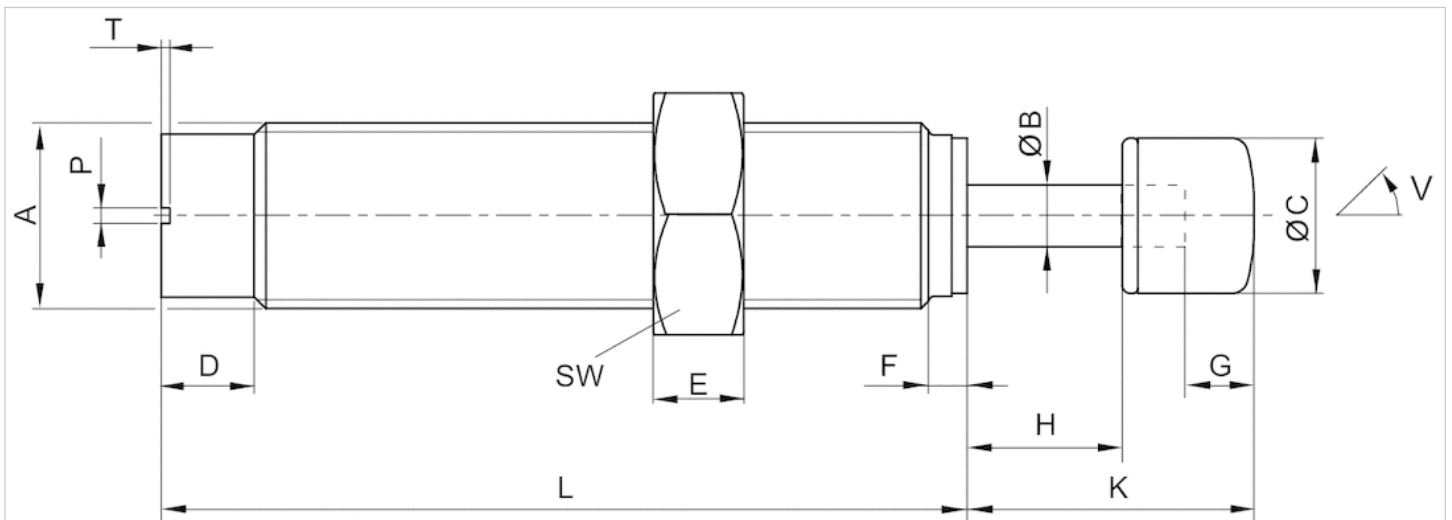

A = mounting thread
V = tilt

Dimensions

Type	Mounting thread
SA1-MC	M6x0,5

Industrial shock absorber, Series SA1-MC

- Cushioning self-compensating
- Mounting Lock nut
- Mounting thread M14x1,5
- SA1-MC



Ambient temperature min./max.	-20 ... 80 °C
Medium	Oil
Mounting	Lock nut
Mounting thread	M14x1,5
Weight	0.05 kg

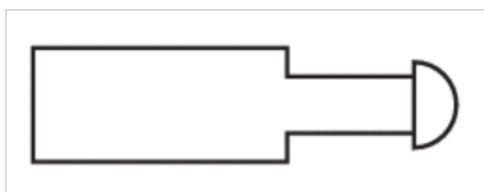

Technical data

Part No.	Mounting thread	Stroke	Max. energy absorption/stroke	Max. energy absorption/hour
R412010305	M14x1,5	14 mm	30 Nm	50000 Nm

Part No.	Effective mass me	Return spring force	Fig.
	min./max.	min./max.	
R412010305	9.9 ... 76 kg	13 ... 23 N	Fig. 1

Technical information

Material	
Cylinder tube	Steel, salt bath nitrocarburized
Piston rod	Stainless steel, hardened
sealing for piston rod	Nitrile butadiene rubber

Dimensions

Fig. 1

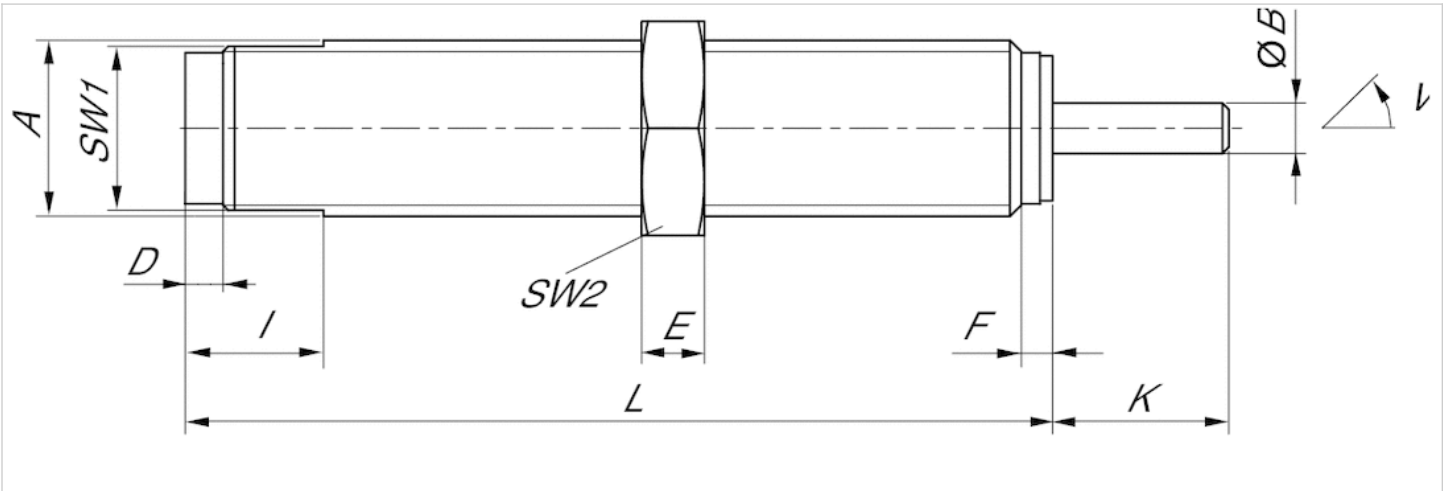

A = mounting thread
V = tilt

Dimensions

Part No.	Type	Mounting thread	ØB	D	E	F	I	K	L	SW1	SW2	W [°]
R412010305	SA1-MC	M14x1,5	4	3	5	2.5	11	14	69	13	17	4

Dimensions

Fig. 2

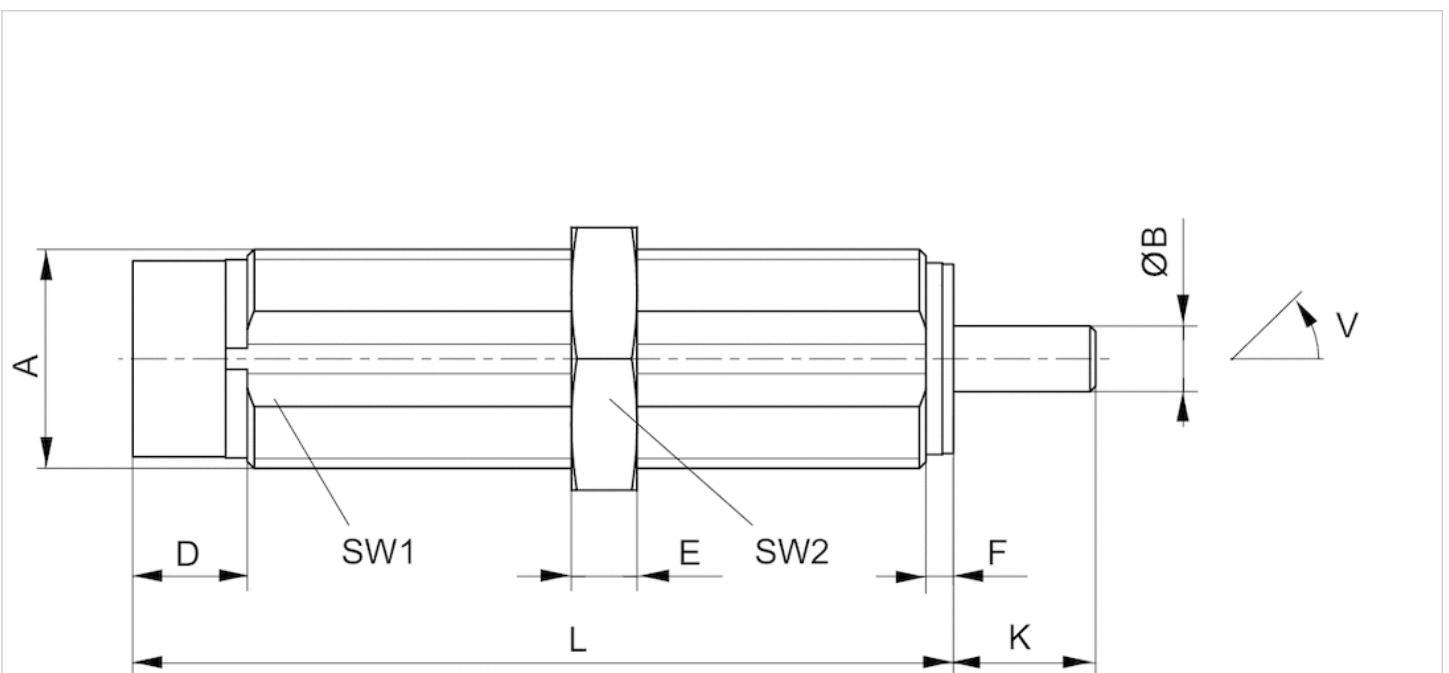

A = mounting thread
V = tilt

Dimensions

Type	Mounting thread
SA1-MC	M14x1,5

Industrial shock absorber, Series SA2-MS

- for MSC-12-HM, MSC-16-HM MSC-20-HM
- Cushioning self-compensating
- Mounting Lock nut
- Mounting thread M8x1 M12x1
- SA2-MS



Ambient temperature min./max.

-20 ... 80 °C

Medium

Oil

Mounting

Lock nut

Weight

See table below

The delivered product varies from that in the illustration. See the drawing for an exact description.

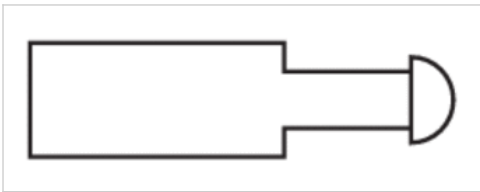

Technical data

Part No.	for series	Mounting thread	Stroke	Max. energy absorption/stroke
R412010370	MSC-12-HM, MSC-16-HM	M8x1	7 mm	3 Nm
R412010371	MSC-20-HM	M12x1	10 mm	8 Nm

Part No.	Max. energy absorption/hour	Effective mass me	Return spring force
		min./max.	min./max.
R412010370	14100 Nm	1.7 ... 50 kg	2.5 ... 6 N
R412010371	26000 Nm	5 ... 57 kg	3.5 ... 7 N

Part No.	sealing for piston rod	Stop	Weight
R412010370	Polyurethane	Polyoxymethylene	0.015 kg
R412010371	Nitrile butadiene rubber	-	0.035 kg

Technical information

Material	
Cylinder tube	Steel, salt bath nitrocarburized
Piston rod	Stainless steel, hardened

Material	
sealing for piston rod	Polyurethane Nitrile butadiene rubber
Mounting ring	Polyoxymethylene

Dimensions

Dimensions

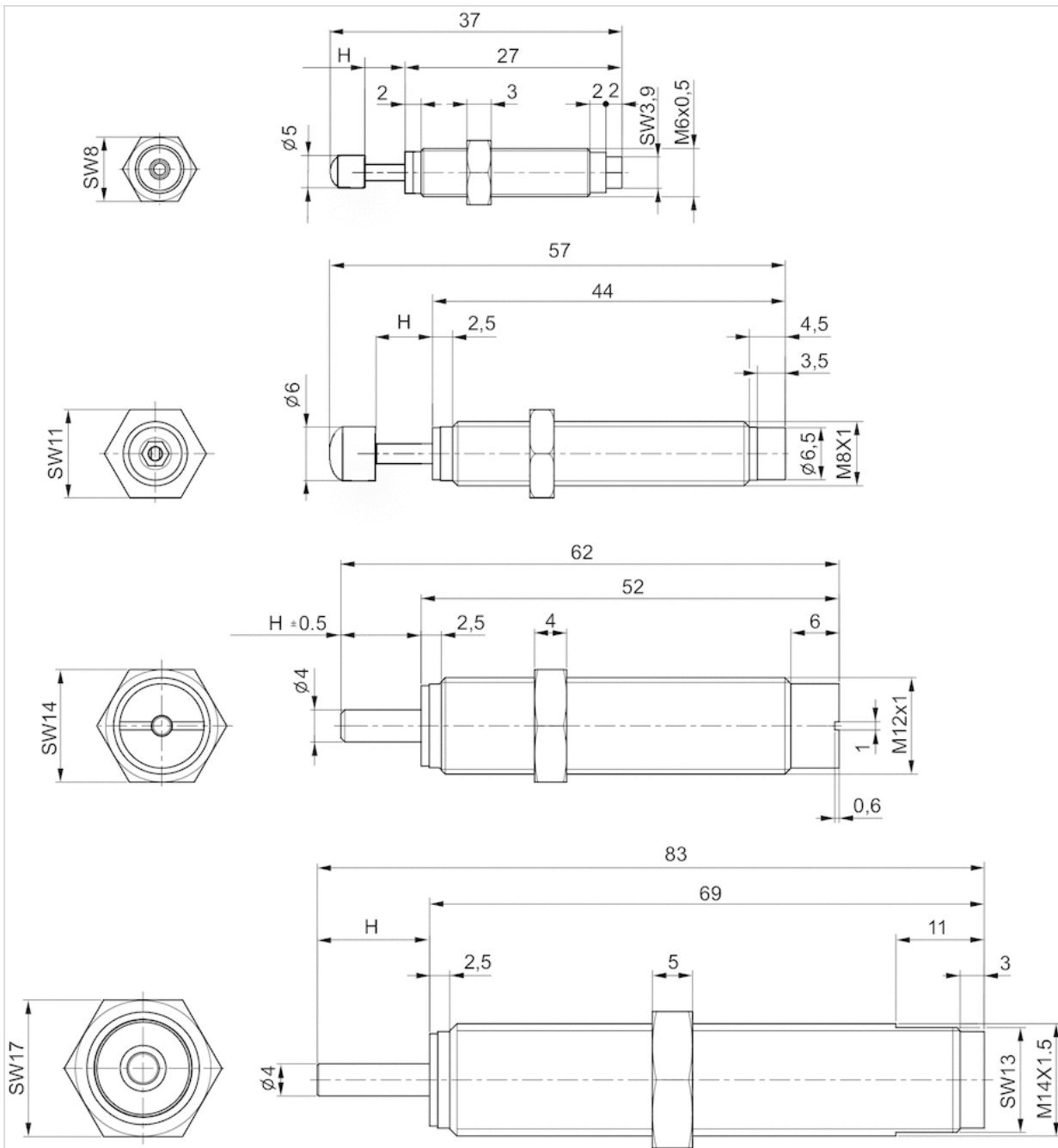

H = stroke

End position lock, Series LU



Release pressure	4.5 ... 10 bar
Ambient temperature min./max.	0 ... 60 °C
Medium temperature min./max.	0 ... 60 °C
Medium	Compressed air

Technical data

Part No.	Max. permissible useful load
	MSC
R402006023	3.5 kg
R402006027	8.5 kg

Dimensions

Dimensions

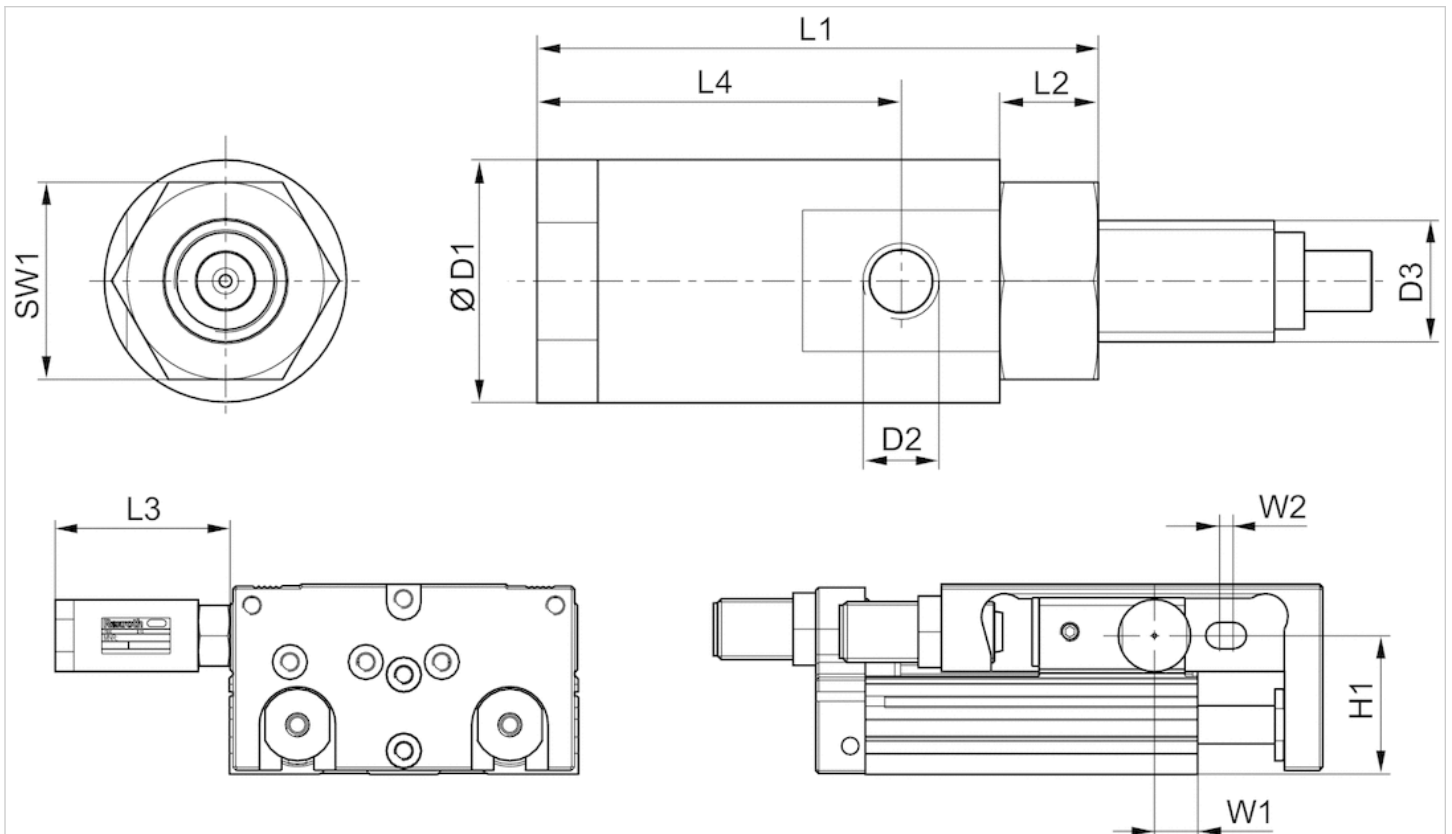

Dimensions

Materialnummer	MSC Ø	Ø D1	D2	D3	H1	L1	L2
R402006023	8	16	M5	M8x1	19,5	37	6.5
	12				23		
	16				28,2		
R402006027	20	19	M5	M10x1	36,5	46.2	8.4
	25				42,5		

Materialnummer	L3	L4	SW1	W1	W2
R402006023	38,3	24	13	19,3	5
	35,3			10	
	34,5			10	
R402006027	42.8	30.3	16	11,5	3,5
				14,8	5

Stroke setting range for return stroke max. 5 mm

Sensor, Series ST4

- 4 mm T-slot
- with cable
- Plug, M8, 3-pin
- UL certification
- Reed electronic PNP electronic NPN
- Direct mounting for series PRA, SSI, GSU, RTC, CKP, GSP, MSC, MSN, RCM, CVI
- Indirect mounting for series MNI, CSL-RD, ICM



Certificates	UL (Underwriters Laboratories) cULus RoHS
Ambient temperature min./max.	-30 ... 80 °C
Protection class	IP65, IP67
Switching point precision	±0,1 mT
Min./max. DC operating voltage	See table below
Switching logic	NO (make contact)
Display	LED
LED status display	Yellow
Vibration resistance	10 - 55 Hz, 1 mm
Shock resistance	30 g / 11 ms
Cable length L	0.3 m
Mounting screw	Combination: slotted and hexagon socket

Technical data

Part No.		for
R412019682		PRA, SSI, GSU, RTC, CKP, GSP, MSC, MSN, RCM, CVI
R412019683		PRA, SSI, GSU, RTC, CKP, GSP, MSC, MSN, RCM, CVI
R412019694		PRA, SSI, GSU, RTC, CKP, GSP, MSC, MSN, RCM, CVI

Part No.	Type of contact	Cable length L	Min./max. DC operating voltage
R412019682	Reed	0.3 m	5 ... 30 V DC
R412019683	electronic PNP	0.3 m	10 ... 30 V DC
R412019694	electronic NPN	0.3 m	10 ... 30 V DC

Part No.	Voltage drop U at I _{max}	DC switching current, max.
R412019682	≤ 0,5 V	0.13 A
R412019683	≤ 2,5 V	0.1 A
R412019694	≤ 2,5 V	0.1 A

Part No.	AC switching current, max.	Switching capacity
R412019682	0.13 A	3 W / 3 VA
R412019683	-	-
R412019694	-	-

Part No.	Version
R412019682	Protected against polarity reversal
R412019683	short circuit resistant Protected against polarity reversal
R412019694	short circuit resistant Protected against polarity reversal

Technical information

The max. switching capacity must not be exceeded.

Technical information

Material	
Housing	Polyamide fiber-glass reinforced
Cable sheath	Polyurethane

Dimensions

Dimensions

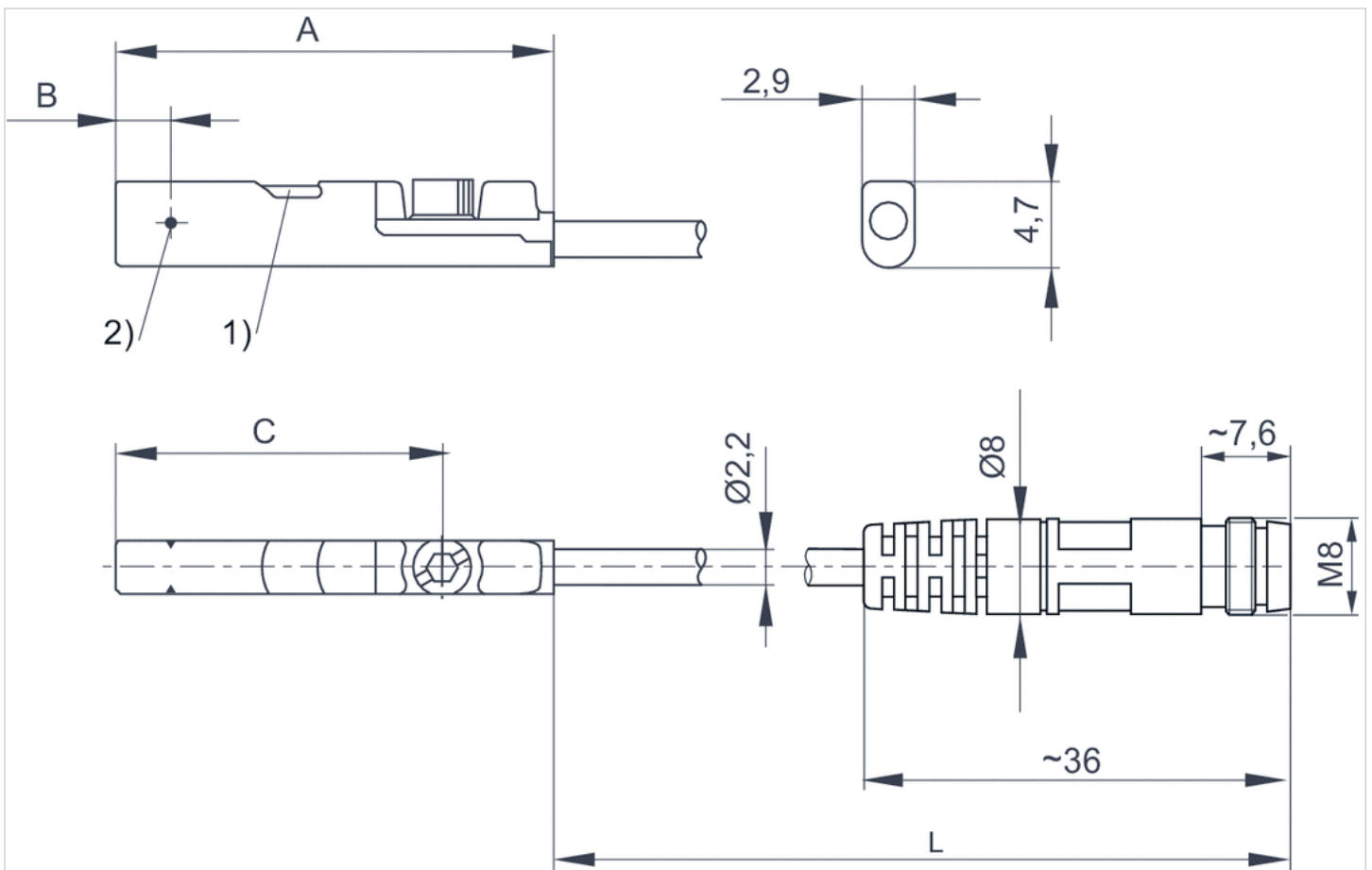

1) LED 2) Switching point
L = cable length

Dimensions

Part No.	A	B	C
R412019682	26.3	6.3	20.3
R412019683	23.7	2.8	17.7
R412019694	23.7	2.8	17.7

Pin assignments

Pin assignments

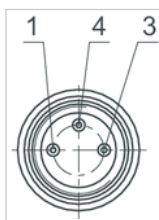

Pin	1	3	4
Allocation	(+)	(-)	(OUT)

Sensor, Series ST4

- 4 mm T-slot
- with cable
- Plug, M8, 3-pin, with knurled screw
- UL certification
- Reed electronic PNP
- Direct mounting for series PRA, SSI, GSU, RTC, CKP, GPC, MSC, MSN, RCM, CVI
- Indirect mounting for series MNI, CSL-RD, ICM



Certificates	UL (Underwriters Laboratories) cULus RoHS
Ambient temperature min./max.	-30 ... 80 °C
Protection class	IP65, IP67
Switching point precision	±0,1 mT
Min./max. DC operating voltage	See table below
Switching logic	NO (make contact)
Display	LED
LED status display	Yellow
Vibration resistance	10 - 55 Hz, 1 mm
Shock resistance	30 g / 11 ms
Cable length L	0.3 0.5 m
Mounting screw	Combination: slotted and hexagon socket

Technical data

Part No.		for
R412019490		PRA, SSI, GSU, RTC, CKP, GPC, MSC, MSN, RCM, CVI
R412019686		PRA, SSI, GSU, RTC, CKP, GPC, MSC, MSN, RCM, CVI
R412019493		PRA, SSI, GSU, RTC, CKP, GPC, MSC, MSN, RCM, CVI
R412019687		PRA, SSI, GSU, RTC, CKP, GPC, MSC, MSN, RCM, CVI

Part No.	Type of contact	Cable length L	Min./max. DC operating voltage
R412019490	Reed	0.3 m	5 ... 30 V DC
R412019686	Reed	0.5 m	5 ... 30 V DC
R412019493	electronic PNP	0.3 m	10 ... 30 V DC
R412019687	electronic PNP	0.5 m	10 ... 30 V DC

Part No.	Voltage drop U at I _{max}	DC switching current, max.
R412019490	≤ 0,5 V	0.13 A
R412019686	≤ 0,5 V	0.13 A
R412019493	≤ 2,5 V	0.1 A
R412019687	≤ 2,5 V	0.1 A

Part No.	AC switching current, max.	Switching capacity
R412019490	0.13 A	3 W / 3 VA

Part No.	AC switching current, max.	Switching capacity
R412019686	0.13 A	3 W / 3 VA
R412019493	-	-
R412019687	-	-

Part No.	Version
R412019490	Protected against polarity reversal
R412019686	Protected against polarity reversal
R412019493	short circuit resistant Protected against polarity reversal
R412019687	short circuit resistant Protected against polarity reversal

Technical information

The max. switching capacity must not be exceeded.

Technical information

Material	
Housing	Polyamide fiber-glass reinforced
Cable sheath	Polyurethane

Dimensions

Dimensions

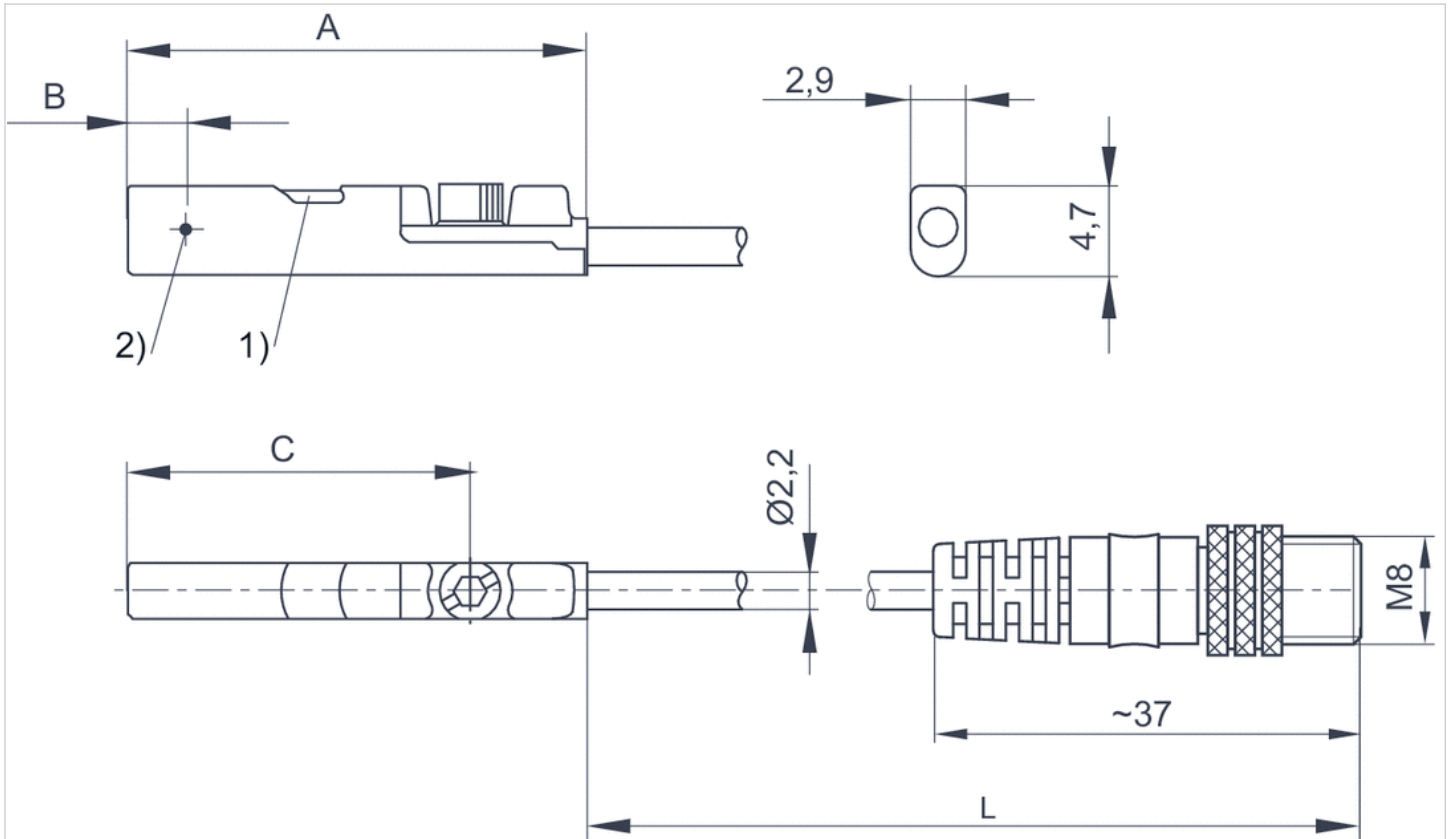

1) LED 2) Switching point
L = cable length

Dimensions

Part No.	A	B	C
R412019490	26.3	6.3	20.3
R412019686	26.3	6.3	20.3
R412019493	23.7	2.8	17.7
R412019687	23.7	2.8	17.7

Pin assignments

Pin assignments

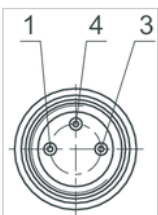

Pin	1	3	4
Allocation	(+)	(-)	(OUT)

Sensor, Series ST4

- 4 mm T-slot
- with cable
- open cable ends, 3-pin
- UL certification
- Reed electronic PNP electronic NPN
- Direct mounting for series PRA, SSI, GSU, RTC, CKP, GPC, MSC, MSN, RCM, CVI
- Indirect mounting for series MNI, CSL-RD, ICM



Certificates	UL (Underwriters Laboratories) cULus RoHS
Ambient temperature min./max.	-30 ... 80 °C
Protection class	IP65, IP67
Switching point precision	±0,1 mT
Min./max. DC operating voltage	See table below
Switching logic	NO (make contact)
Display	LED
LED status display	Yellow
Vibration resistance	10 - 55 Hz, 1 mm
Shock resistance	30 g / 11 ms
Cable length L	3 5 m
Mounting screw	Combination: slotted and hexagon socket

Technical data

Part No.		for
R412019488		PRA, SSI, GSU, RTC, CKP, GPC, MSC, MSN, RCM, CVI
R412019489		PRA, SSI, GSU, RTC, CKP, GPC, MSC, MSN, RCM, CVI
R412019680		PRA, SSI, GSU, RTC, CKP, GPC, MSC, MSN, RCM, CVI
R412019681		PRA, SSI, GSU, RTC, CKP, GPC, MSC, MSN, RCM, CVI
R412019684		PRA, SSI, GSU, RTC, CKP, GPC, MSC, MSN, RCM, CVI
R412019685		PRA, SSI, GSU, RTC, CKP, GPC, MSC, MSN, RCM, CVI

Part No.	Type of contact	Cable length L	Min./max. DC operating voltage
R412019488	Reed	3 m	5 ... 30 V DC
R412019489	Reed	5 m	5 ... 30 V DC
R412019680	electronic PNP	3 m	10 ... 30 V DC
R412019681	electronic PNP	5 m	10 ... 30 V DC
R412019684	electronic NPN	3 m	10 ... 30 V DC
R412019685	electronic NPN	5 m	10 ... 30 V DC

Part No.	Voltage drop U at I _{max}	DC switching current, max.
R412019488	≤ 0,5 V	0.13 A
R412019489	≤ 0,5 V	0.13 A
R412019680	≤ 2,5 V	0.1 A
R412019681	≤ 2,5 V	0.1 A

Part No.	Voltage drop U at I _{max}	DC switching current, max.
R412019684	≤ 2,5 V	0.1 A
R412019685	≤ 2,5 V	0.1 A

Part No.	AC switching current, max.	Switching capacity
R412019488	0.13 A	3 W / 3 VA
R412019489	0.13 A	3 W / 3 VA
R412019680	-	-
R412019681	-	-
R412019684	-	-
R412019685	-	-

Part No.	Version
R412019488	Protected against polarity reversal
R412019489	Protected against polarity reversal
R412019680	short circuit resistant Protected against polarity reversal
R412019681	short circuit resistant Protected against polarity reversal
R412019684	short circuit resistant Protected against polarity reversal
R412019685	short circuit resistant Protected against polarity reversal

Technical information

The max. switching capacity must not be exceeded.

Technical information

Material	
Housing	Polyamide fiber-glass reinforced
Cable sheath	Polyurethane

Dimensions

Dimensions

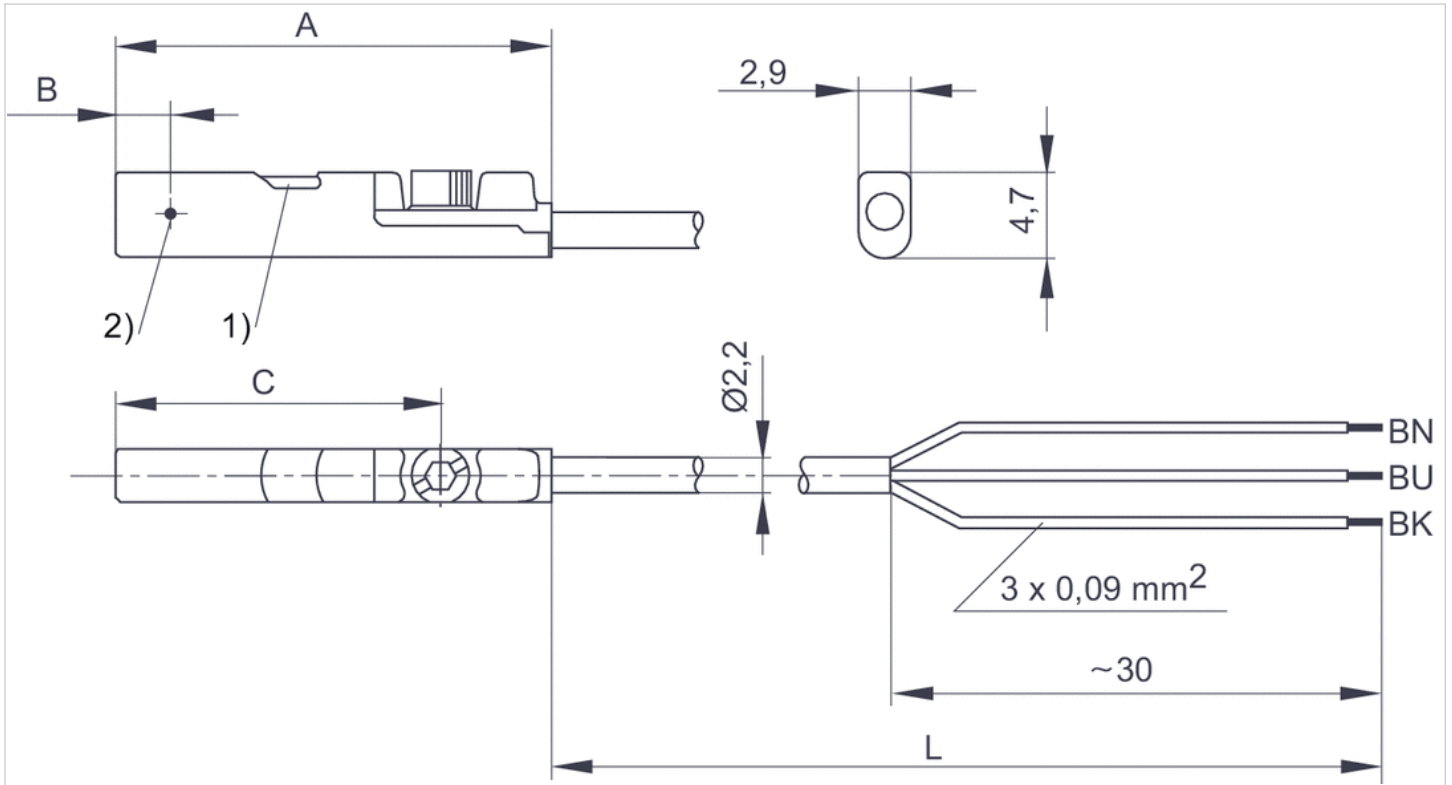

1) LED 2) Switching point

L = cable length

BN = brown, BK = black, BU = blue

Dimensions

Part No.	A	B	C
R412019488	26.3	6.3	20.3
R412019489	26.3	6.3	20.3
R412019680	23.7	2.8	17.7
R412019681	23.7	2.8	17.7
R412019684	23.7	2.8	17.7
R412019685	23.7	2.8	17.7



Sensor, Series ST4

- 4 mm T-slot
- with cable
- Plug, M12, 3-pin, with knurled screw
- UL certification
- Reed electronic PNP
- Direct mounting for series PRA, SSI, GSU, RTC, CKP, GPC, MSC, MSN, RCM, CVI
- Indirect mounting for series MNI, CSL-RD, ICM



Certificates	UL (Underwriters Laboratories) cULus RoHS
Ambient temperature min./max.	-30 ... 80 °C
Protection class	IP65, IP67
Switching point precision	±0,1 mT
Min./max. DC operating voltage	See table below
Switching logic	NO (make contact)
Display	LED
LED status display	Yellow
Vibration resistance	10 - 55 Hz, 1 mm
Shock resistance	30 g / 11 ms
Cable length L	0.3 m
Mounting screw	Combination: slotted and hexagon socket

Technical data

Part No.		for
R412019688		PRA, SSI, GSU, RTC, CKP, GPC, MSC, MSN, RCM, CVI
R412019689		PRA, SSI, GSU, RTC, CKP, GPC, MSC, MSN, RCM, CVI

Part No.	Type of contact	Cable length L	Min./max. DC operating voltage
R412019688	Reed	0.3 m	5 ... 30 V DC
R412019689	electronic PNP	0.3 m	10 ... 30 V DC

Part No.	Voltage drop U at I _{max}	DC switching current, max.
R412019688	≤ 0,5 V	0.13 A
R412019689	≤ 2,5 V	0.1 A

Part No.	AC switching current, max.	Switching capacity
R412019688	0.13 A	3 W / 3 VA
R412019689	-	-

Part No.	Version
R412019688	Protected against polarity reversal

Part No.	Version
R412019689	short circuit resistant Protected against polarity reversal

Technical information

The max. switching capacity must not be exceeded.

Technical information

Material	
Housing	Polyamide fiber-glass reinforced
Cable sheath	Polyurethane

Dimensions

Dimensions

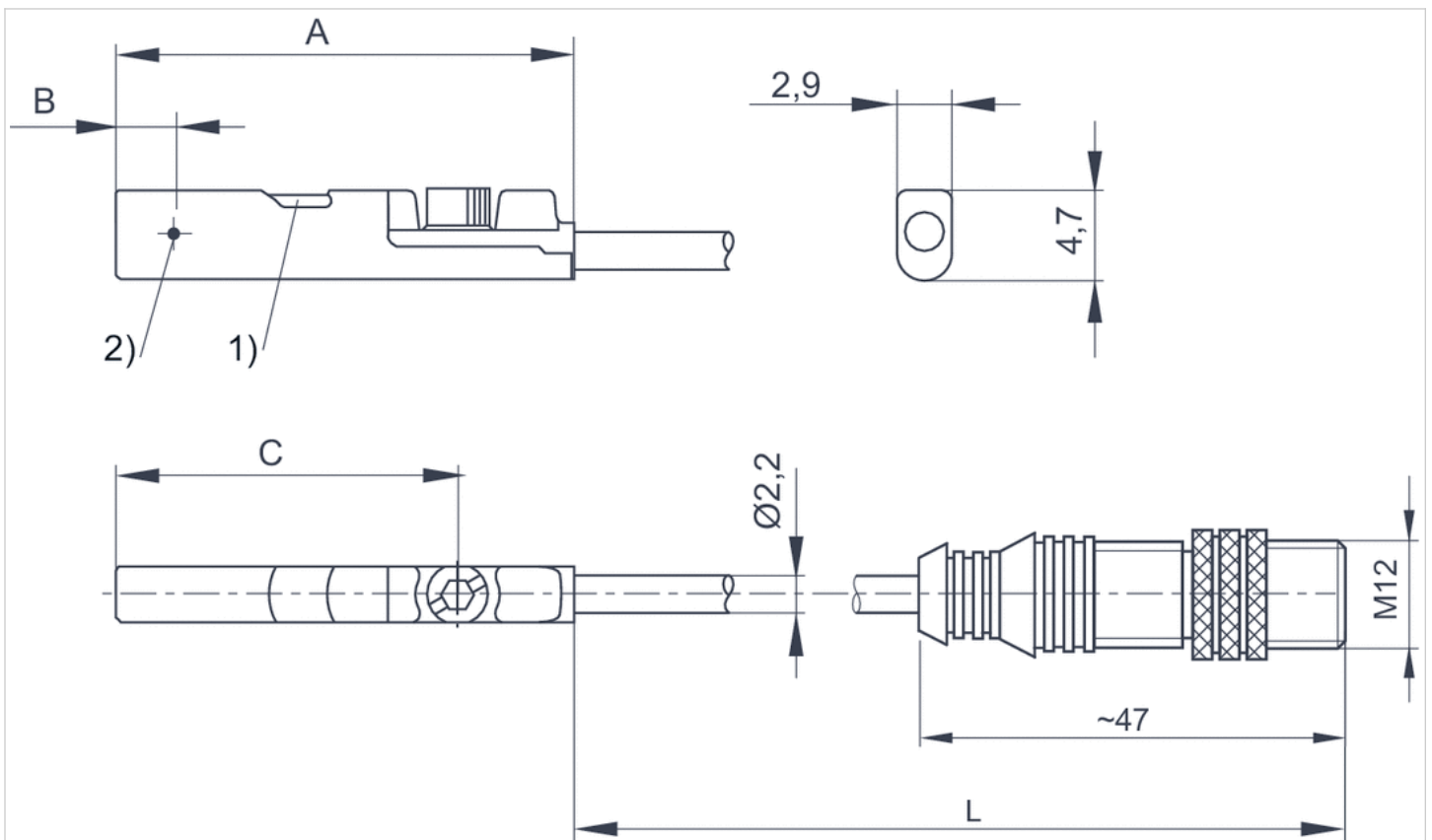

1) LED 2) Switching point
L = cable length

Dimensions

Part No.	A	B	C
R412019688	26.3	6.3	20.3
R412019689	23.7	2.8	17.7

Pin assignments

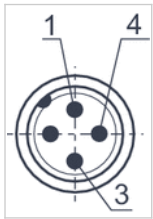

Pin	1	3	4
Allocation	(+)	(-)	(OUT)

Sensors, Series ST4-2P

- 4 mm T-slot
- number of switching points 2
- with cable
- without wire end ferrule, tin-plated, 4-pin
- electronic PNP
- 2 switching points
- electronic PNP
- Direct mounting for series PRA, SSI, RTC, GPC, MSC, MSN, RCM, CVI
- Indirect mounting for series MNI, CSL-RD, ICM

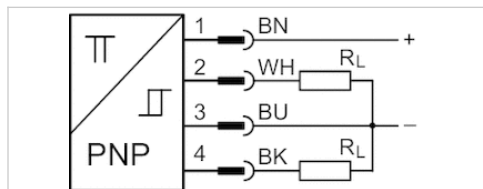

Certificates	RoHS
Ambient temperature min./max.	-20 ... 75 °C
Protection class	IP65, IP67
number of switching points	2
Power consumption	15 mA
Min./max. DC operating voltage	12 ... 30 V DC
Repetitive precision max. measuring range	0,1 mT
Hysteresis	1 mT
Switching logic	NO (make contact)
Display	LED
LED status display	Yellow
Display	2 LED
Vibration resistance	10 - 55 Hz, 1 mm
Shock resistance	30 g / 11 ms
Cable length L	2 m
Mounting screw	with hexagon socket

Technical data

Part No.	for	Type of contact	Cable length L
R412010139	PRA, SSI, RTC, GPC, MSC, MSN, RCM, CVI	electronic PNP	2 m

Part No.	Detection range max.	Voltage drop U at I _{max}	DC switching current, max.
R412010139	50 mm	≤ 2,2 V	0.15 A

Part No.	Function	Version
R412010139	electronic PNP	short circuit resistant Protected against polarity reversal

Technical information

Material	
Housing	Polyamide
Cable sheath	Polyurethane

Dimensions

Dimensions

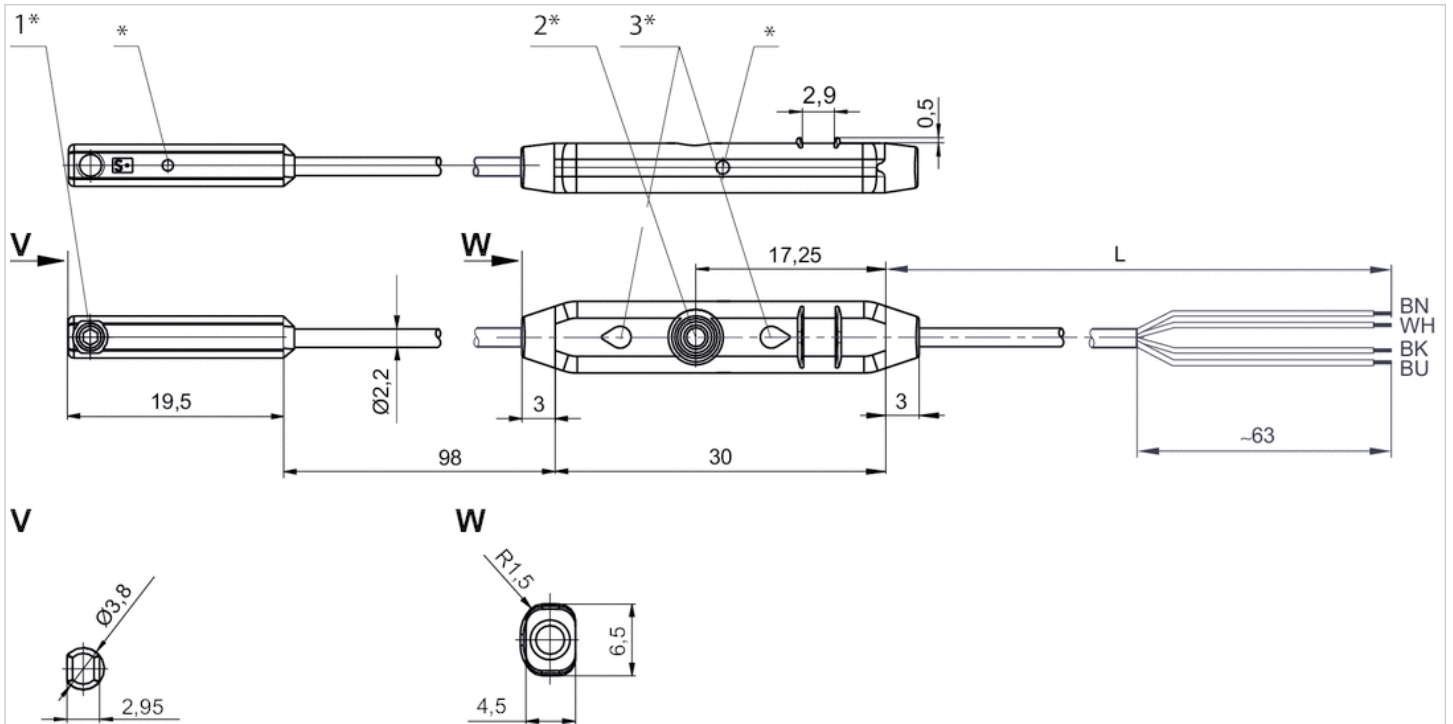

1* = mounting screw 2* = teach button 3* = LED

L = cable length

(1) BN=brown

(2) WH=white

(3) BU=blue

(4) BK=black

* Switching point

Sensors, Series ST4-2P

- 4 mm T-slot
- number of switching points 2
- with cable
- Plug, M8x1, 4-pin, with knurled screw
- electronic PNP
- 2 switching points
- electronic PNP
- Direct mounting for series PRA, SSI, RTC, GPC, MSC, MSN, RCM, CVI
- Indirect mounting for series MNI, CSL-RD, ICM

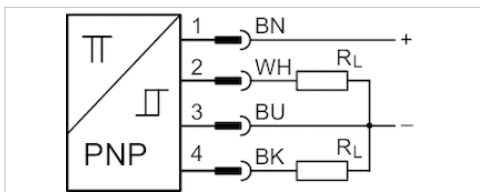

Certificates	RoHS
Ambient temperature min./max.	-20 ... 75 °C
Protection class	IP65, IP67
number of switching points	2
Power consumption	15 mA
Min./max. DC operating voltage	12 ... 30 V DC
Repetitive precision max. measuring range	0,1 mT
Hysteresis	1 mT
Switching logic	NO (make contact)
Display	LED
LED status display	Yellow
Display	2 LED
Vibration resistance	10 - 55 Hz, 1 mm
Shock resistance	30 g / 11 ms
Cable length L	0.3 m
Mounting screw	with hexagon socket

Technical data

Part No.	for	Type of contact	Cable length L
R412010140	PRA, SSI, RTC, GPC, MSC, MSN, RCM, CVI	electronic PNP	0.3 m

Part No.	Detection range max.	Voltage drop U at I _{max}	Function
R412010140	50 mm	≤ 2,2 V	electronic PNP

Part No.	Version
R412010140	short circuit resistant Protected against polarity reversal

Technical information

Material	
Housing	Polyamide
Cable sheath	Polyurethane

Dimensions

Dimensions

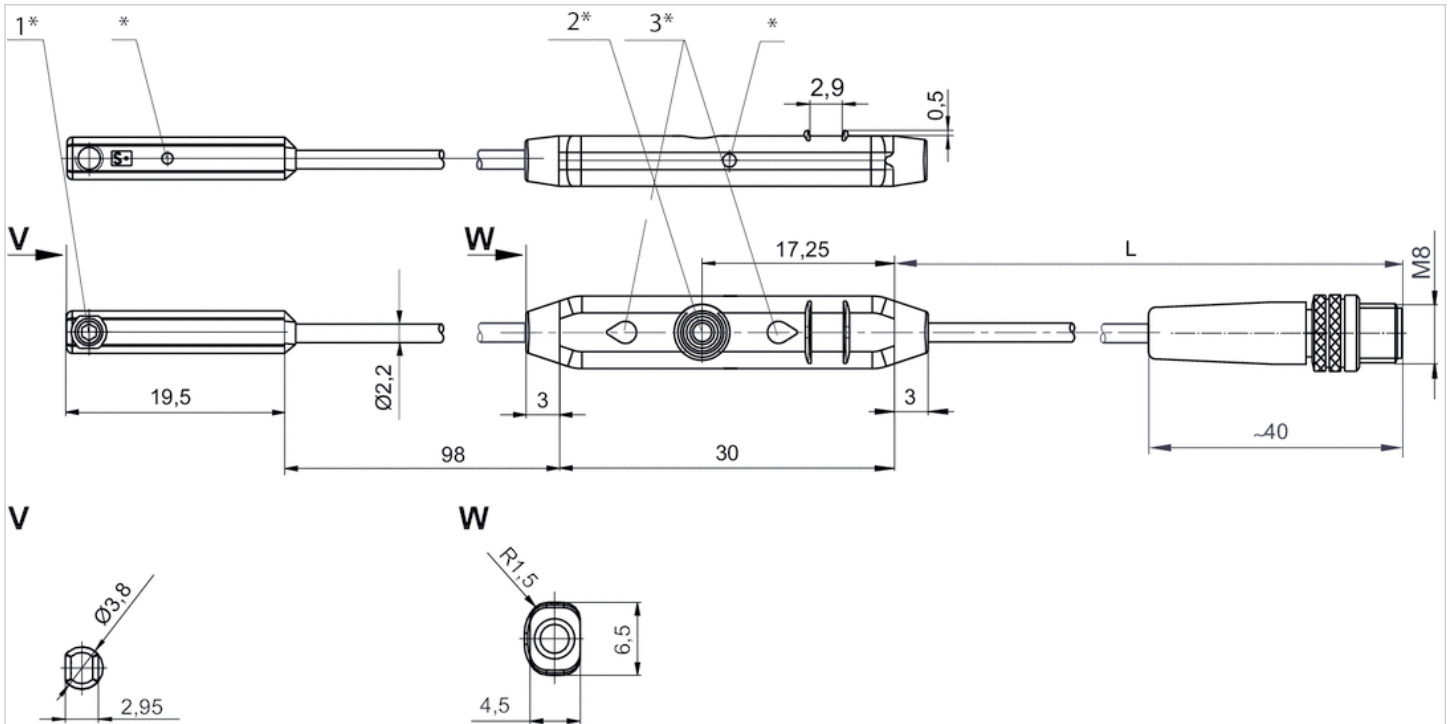

1* = mounting screw 2* = teach button 3* = LED
 L = cable length
 * Switching point

Pin assignments

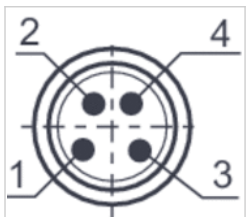

Pin	1	2	3	4
Allocation	(+)	(OUT)	(-)	(OUT)

Efficient pneumatic solutions, our program: cylinders and drives, valves and valve systems, air supply management



Visit us: Emerson.com/Aventics

Your local contact: Emerson.com/contactus



Emerson.com



[Facebook.com/EmersonAutomationSolutions](https://www.facebook.com/EmersonAutomationSolutions)



[LinkedIn.com/company/Emerson-Automation-Solutions](https://www.linkedin.com/company/Emerson-Automation-Solutions)



[Twitter.com/EMR_Automation](https://twitter.com/EMR_Automation)

An example configuration is depicted on the title page. The delivered product may thus vary from that in the illustration. Subject to change. This Document, as well as the data, specifications and other information set forth in it, are the exclusive property of AVENTICS GmbH. It may not be reproduced or given to third parties without its consent. Only use the AVENTICS products shown in industrial applications. Read the product documentation completely and carefully before using the product. Observe the applicable regulations and laws of the respective country. When integrating the product into applications, note the system manufacturer's specifications for safe use of the product. The data specified only serve to describe the product. No statements concerning a certain condition or suitability for a certain application can be derived from our information. The information given does not release the user from the obligation of own judgment and verification. It must be remembered that the products are subject to a natural process of wear and aging.

The Emerson logo is a trademark and service mark of Emerson Electric Co. Brand logotype are registered trademarks of one of the Emerson family of companies. All other marks are the property of their respective owners. © 2017 Emerson Electric Co. All rights reserved.
2019-03



CONSIDER IT SOLVED™