

FEATURES

- Immersion tank system made of steel with welded end covers with CE approval according to Directive 2009/105/EC – PED 97/23/EC
- Immersed valve system with special diaphragm design offers highest peak pressure and best flow performance operating features required for dust collector applications
- The high quality diaphragms are reinforced and wear resistant to guarantee a long operating life, even under harsh conditions
- Possibility to apply different combinations of pitch distances
- Service connections for different accessories such as: filter regulator, pressure gauge, safety valve and automatic/manual drain valve
- Available with hose and threaded blow pipe connections
- The integral operators are provided with epoxy moulded F-class coils

GENERAL

Differential pressure (PS) 0,35 to 8 bar [1 bar = 100kPa]
Ambient temperature range -10 to +80°C

fluid	temperature range (TS)	seal materials
air	-10 to +80°C	CR (chloroprene)

CONSTRUCTION

Tank	Steel, grey
Bonnet	Aluminium
Bolts	Stainless steel
Core tube	Stainless steel
Core and plugnut	Stainless steel
Spring	Stainless steel
Sealing & discs	NBR (nitrile)
Diaphragm	CR
Shading coil	Copper
Coil insulation class	F
Connector	Spade plug (cable Ø 6-10mm)
Connector specification	ISO 4400
Electrical safety	IEC 335

ELECTRICAL CHARACTERISTICS

Standard voltages DC (=) : 24V - 48V;
 (Other voltages and 60 Hz on request) AC (~) : 24V - 48V - 115V - 230V / 50Hz

coil type	nominal power ratings				protection
	inrush	holding		hot/cold	
	~ (VA)	~ (VA)	~ (W)	= (W)	
CMXX-FT	55	23	10,5	-	moulded IP65
CMXX-FT	-	-	-	14 / 19,7	

SPECIFICATIONS

pipe size	orifice size (mm)	flow coefficient Kv (m³/h) (l/min)		operating pressure differential (bar)		catalogue number	
				min	max. (PS)		
					air ~ / =	hose	threaded
8" Tank System							
1 1/2"	40	46	768	0,35	8	SCG357ANxx ^{(1) (2)}	SCG357AOxx ^{(1) (2)}

⁽¹⁾ Standard tank has round ends. For flat ends use suffix FE

⁽²⁾ xx indicates the number of valves

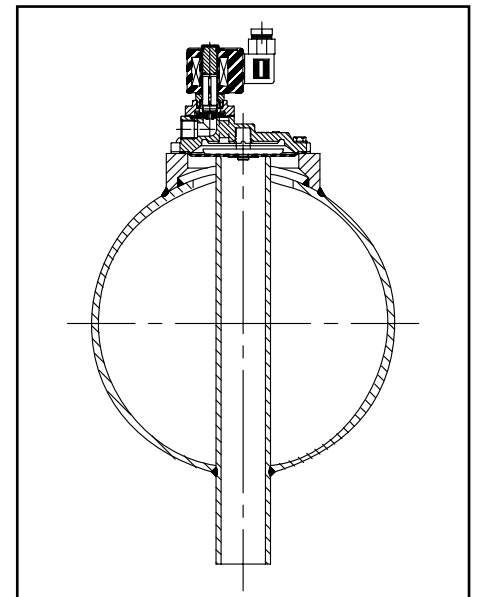

ORDERING

Example: Dimension code for a 4 valves tank system:

Tank diameter	8"
Operator	SC, 24V/DC
Pipe size	1 1/2"
Connection	Hose (see fig. 1: Connection Type)
Number of valves	4 pcs
Start and End distance	170 mm
Standard pitch	180 mm
Deviating pitch	Between valve no. 3 and no. 4 is position D (see fig. 1) 200 mm
Catalogue number	SCG357AN04 24V/DC
Dimension code	170180D200

ORDERING EXAMPLE TANK SYSTEM:

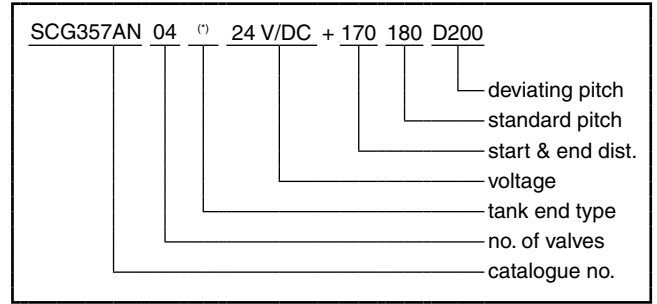

SPARE PARTS KITS

catalogue number	spare parts kit no.
SCG357ANxx	~/=
SCG357AOxx	C113827

DIMENSIONS (mm)

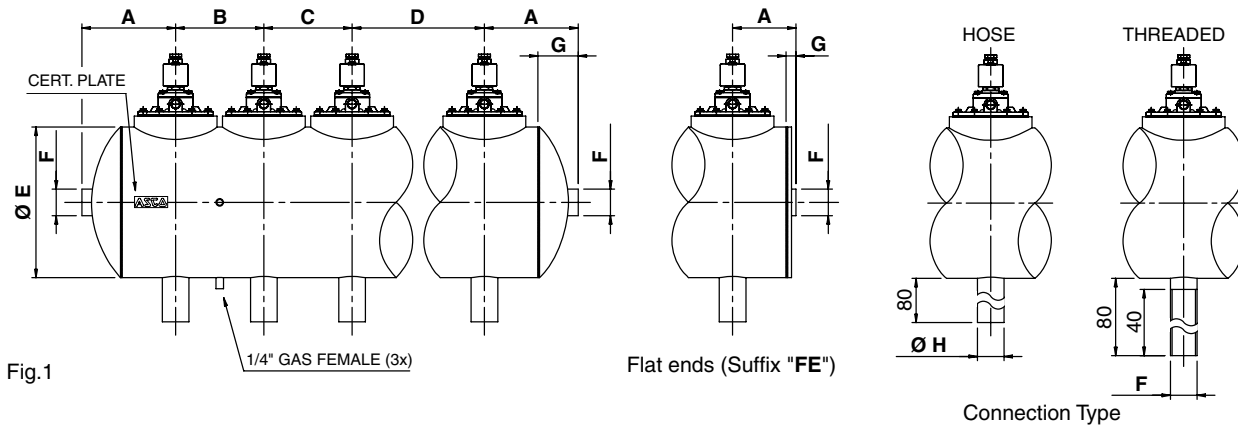

Fig.1

Flat ends (Suffix "FE")

Connection Type

tank diameter	fig.	A		B / C / D		A		Ø E	F	G		Ø H
		min. start distance (round)	(flat)	(round)	(flat)	(round)	(flat)					
8"	1	170	118	160	160	170	118	218,1	G 1 1/2"	70	18	48,3

(*) For standard tank (round ends) use no suffix, for flat ends use suffix FE

MOUNTING BRACKETS

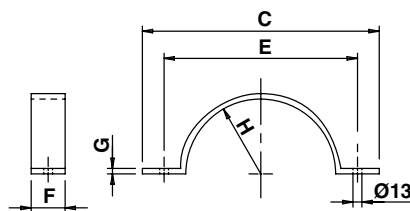

Fig.2 - Contra bracket

tank diameter	fig.	C	Ø E	F	G	H
8"	2	348	284	50	8	110

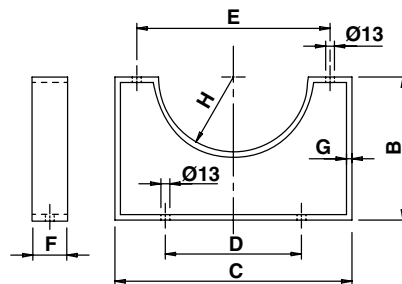

Fig.3 - Bracket

tank diameter	fig.	B	C	D	Ø E	F	G	H
8"	3	210	348	200	284	50	8	110

INSTALLATION

- Tank System can be mounted in any position. We can supply standard mounting brackets with each tank by specifying suffix MB behind the catalogue number (see figure 2 and 3)
- Installation / maintenance instructions and declaration of conformity are included with each tank system
- Spare part kits and coils are available