

SLAM-SHUT VALVES

Type BM6X



BM6X Slam-Shut Valves

Slam-shut valves

The BM6X Series axial flow slam-shut valve is an automatic shut-off appliance suitable for installation as a safety device in regulating stations and on gas transfer and distribution lines.

The reduced face to face dimension facilitates installation even in existing regulating station that are not equipped with shut-off devices.

The slam-shut valve rapidly interrupts the gas flow in cases in which the pressure at the control point or points reaches the set level.

The BM6X slam-shut valves are of the type with an off-center butterfly disk that is mounted eccentrically.

The gas flow favors closure of the valve.

The valve can only be re-opened manually.

The BM6X Series slam-shut valve uses gas from the gas line for operation and therefore it does not require outside sources to operate.

The main features are as follows:

- *Axial flow*
- *Off-center butterfly disk*
- *Pressure control at one or more points in the system*
- *Activation due to pressure increase or decrease*
- *Emergency slam-shut push-button*
- *Button by-pass with automatic return*
- *Manual reset by the sole rotation of the reset shaft*
- *Easy maintenance*



Operation

The BM6X Series slam-shut valve consists of a valve body, a pilot and a by-pass valve.

The valve body has an off-center butterfly disk that is mounted eccentrically on the reset shaft.

A lip seal ensures tightness.

The spring thrust, with the additional weight of the eccentric off-center butterfly disk, ensures punctual and safe closure under any working conditions.

In addition, the compression of the seal, which is determined by the pressure, ensures perfect tightness.

The slam-shut valve can only be opened if the upstream and downstream pressures are equal.

The Type IT/2V by-pass valve with automatic return makes it possible to balance these pressures.

The valve can only be opened manually by rotating the pilot reset shaft.

When the controlled pressure lies within the set levels for the pilot, the latter remains set and prevents rotation of the shaft while keeping the butterfly disk open.

When said pressure changes beyond the set levels, the butterfly disk moves to the closure position.

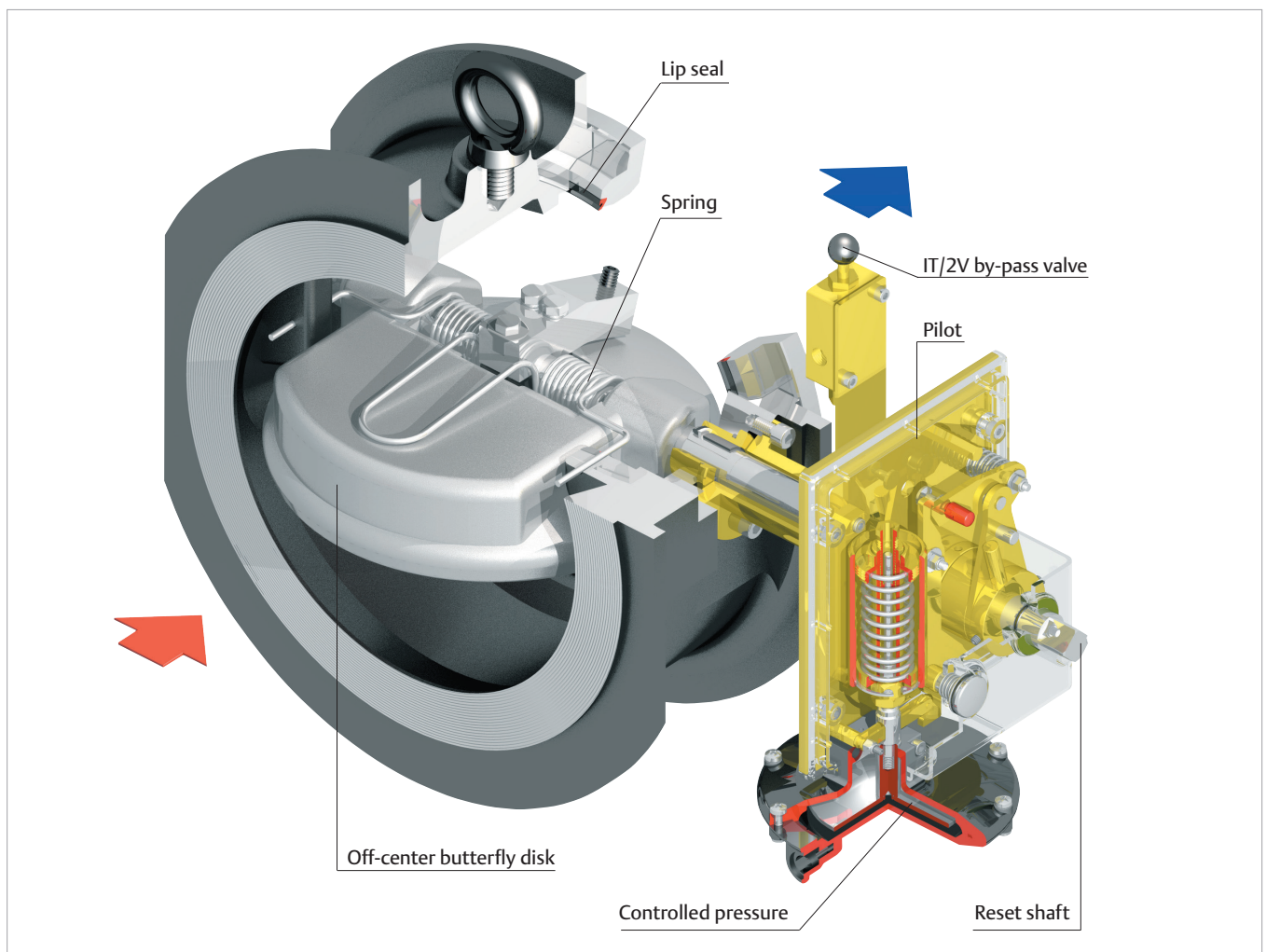

BM6X Slam-Shut Valves

Features

Applications The slam-shut valves in the BM6X Series are used in natural gas reduction, distribution and transfer stations. This product has been designed to be used with fuel gases of 1st and 2nd family according to EN 437, and with other non aggressive and non fuel gases. For any other gases, other than natural gas, please contact your local sales agent.

Construction Features

The flange coupling surfaces are normally supplied with a step and finished with a semicircular profile phonographic groove.

Upon request, the flange coupling surfaces can be supplied with a smooth finish.

Upon request, the valve can be supplied complete with flanges to be welded to the line, stud bolts, nuts and gaskets.

Technical Features

Pressure, bar		ANSI 150	ANSI 300	ANSI 600
Allowable pressure	PS	20	50	100
Inlet pressure range	b _{pu}	0 to 20	0 to 50	0 to 100
Overpressure set range	W _{do}	0.03 to 20	0.03 to 50	0.03 to 80
Underpressure set range	W _{du}	0.01 to 20	0.01 to 50	0.01 to 80
Accuracy class	AG	up to ± 1%		
Response time	t _a	≤ 1 s		

Connections

"Wafer" type body: DN 80 - 100 - 150 - 200 - 250 - 300

Flanged body: DN 150 - 250

Temperature

Standard version

Working -10°C +60°C

Low temperature version

Working -20°C +60°C

Materials

Body: Steel
 Butterfly disk: Cast iron or steel
 Shaft: Steel
 Spring: Stainless steel
 Lip seal: Fluorocarbon (FKM)
 O-ring: Nitrile (NBR) rubber or Fluorocarbon (FKM)

By-Pass Valve Type IT/2V Features

Allowable pressure : PS: 100 bar

Material: Brass

1/4" NPT female threaded pipe fitting

Versions

Hydrogen Ready

Products have been evaluated for material compatibility, potential leakage and permeation and susceptibility to embrittlement for blending applications. Based on an extensive evaluation and testing program, Type BM6X configurations are available for use in Hydrogen applications.

Sour Gases

The version referring to NACE standard is produced for use with sour gases (not available with the OS/80X-R-PN Series pilot).

Application graph based on the amount of H₂S present in the gas

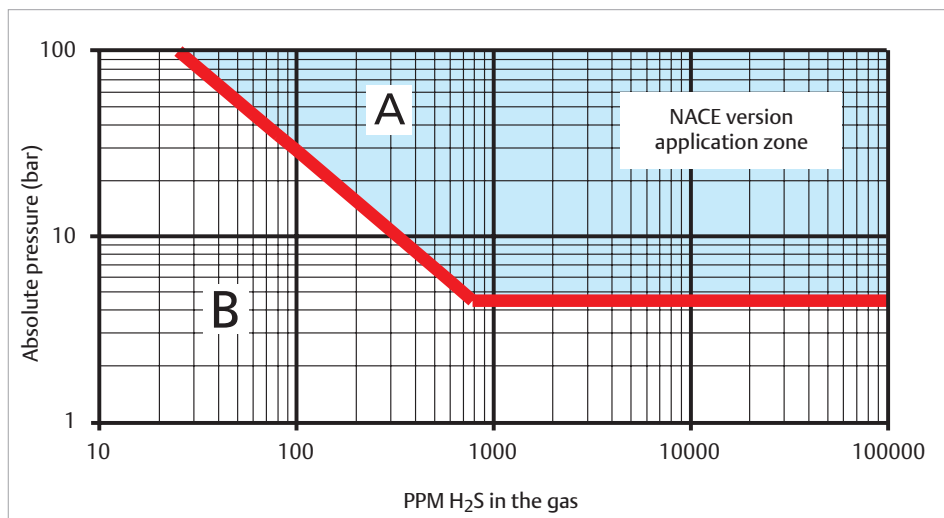

The red line divides the graph into two zones.

The “A” zone indicates the range in which the NACE version must be used.

The “B” zone indicates the range in which that version is not required.



BM6X Slam-Shut Valves

Calculation procedures

The following formulas refer to normal operating conditions in a sub-critical state with: $P_2 > \frac{P_1}{2}$

Symbols

Q = Natural gas flow rate in Stm³/h
 P1 = Absolute inlet pressure in bar
 P2 = Absolute outlet pressure in bar

C_g = Flow rate coefficient
 C1 = Body shape factor
 d = Relative density of the gas

Flow Coefficients

Coefficient	DN 80	DN 100	DN 150	DN 150 Flanged Body	DN 200	DN 250	DN 300
C _g	4500	9000	20250	20776	36000	55800	81000
C1	18						

Flow Rate Q

$$Q = 0.525 \cdot C_g \cdot P_1 \cdot \sin \left(\frac{3417}{C_1} \cdot \sqrt{\frac{P_1 - P_2}{P_1}} \right)^{\text{Deg}}$$

$$Q = 0.525 \cdot C_g \cdot P_1$$

For other gases with different densities, the flow rate calculated with the above formulas must be multiplied by the correction factor:

$$F = \sqrt{\frac{0.6}{d}}$$

Gas	Relative Density, d	Factor, F
Air	1	0.78
Butane	2.01	0.55
Propane	1.53	0.63
Nitrogen	0.97	0.79

DN Size

Calculate the required C_g with the following:

$$C_g = \frac{Q}{0.525 \cdot P_1 \cdot \sin \left(\frac{3417}{C_1} \cdot \sqrt{\frac{P_1 - P_2}{P_1}} \right)^{\text{Deg}}}$$

N.B. The formula appearing above is valid only when the flow rate refers to natural gas. For other gases, divide the flow rate by the correction factor F.

Choose the slam-shut valve with the C_g higher than the calculated value. After having determined the slam-shut valve diameter, it is suggested to check that the velocity on the seal seat is not higher than 80 m/sec. by using the following formula:

$$V = 345.92 \cdot \frac{Q}{DN^2} \cdot \frac{1 - 0.002 \cdot P_u}{1 + P_u}$$

V = Velocity (m/s)
 345.92 = Numerical constant
 Q = Flow rate under standard conditions (Stm³/h)
 DN = Valve nominal diameter (mm)
 P_u = Inlet pressure in relative value (bar)

In case of velocities higher than indicated limits, increase the valve diameter.

Pilot

The following pilots are used with the BM6X slam-shut valves:

- **OS/80X-R Series:** Spring loaded pneumatic device
- **OS/80X-R-PN Series:** Pneumatic device controlled by PRX-PN Series pilots

OS/80X-R

The OS/80X-R Series pilot is supplied in different models according to set ranges required.

Technical Features

Type		Body Resistance, bar	Overpressure Set Range, W_{do} , bar		Underpressure Set Range, W_{du} , bar	
Valve Flow from Left to Right	Valve Flow from Right to Left		Min.	Max.	Min.	Max.
OS/80X-BP-S-R	OS/80X-BP-R	5	0.03	2	0.01	0.60
OS/80X-BPA-D-S-R	OS/80X-BPA-D-R	20				
OS/80X-MPA-D-S-R	OS/80X-MPA-D-R	100	0.50	5	0.25	4
OS/80X-APA-D-S-R	OS/80X-APA-D-R		2	10	0.30	7
OS/84X-S-R	OS/84X-R		5	41	4	16
OS/88X-S-R	OS/88X-R		18	80	8	70

Materials

Type OS/80X-R

Servomotor body: OS/80X-BP-R, OS/80X-BPA-D-R: Aluminum
OS/80X-MPA-D-R, OS/80X-APA-D-R: Steel

Diaphragm: Fabric-finished Nitrile (NBR)
O-ring: Nitrile (NBR) rubber

Types OS/84X-R and OS/88X-R

Servomotor body: Brass
Lip seal: Teflon (PTFE)
O-ring: Nitrile (NBR) rubber



Type OS/80X-BP-R

OS/80X-R-PN

The OS/80X-R-PN Series pilot is supplied in two models:

Type OS/80X-R-PN: Pressure range 0.5 to 40 bar.

Appliance made of a Type OS/80X-APA-D-R set at about 0.4 bar and a variable number of Type PRX/182-PN pilots for overpressure and Type PRX/181-PN for underpressure, as many as necessary to control different points of the installation.

Type OS/84X-R-PN (Safety Accessory): Pressure range 30 to 80 bar.

Appliance made of a Type OS/84X-R set at about 20 bar and a variable number of Type PRX-AP/182-PN pilots for overpressure and Type PRX-AP/181-PN for underpressure, as many as necessary to control different points of the installation.

Technical Features

Model	Body Resistance, bar	Overpressure Set Range, W_{do} , bar		Underpressure Set Range, W_{du} , bar	
		Min.	Max.	Min.	Max.
OS/80X-R-PN	100	0.5	40	0.5	40
OS/84X-R-PN	100	30	80	30	80

Materials

Types PRX/181/182-PN and PRX-AP/181/182-PN

Body: Steel
Diaphragm: Fabric-finished Nitrile (NBR)
O-ring: Nitrile (NBR) rubber

BM6X Slam-Shut Valves

Installation and assembly

Orientations The Type BM6X slam-shut valves are normally installed in lines with a horizontal axis. Vertical axis installation is possible but only with a flow direction from top to bottom.

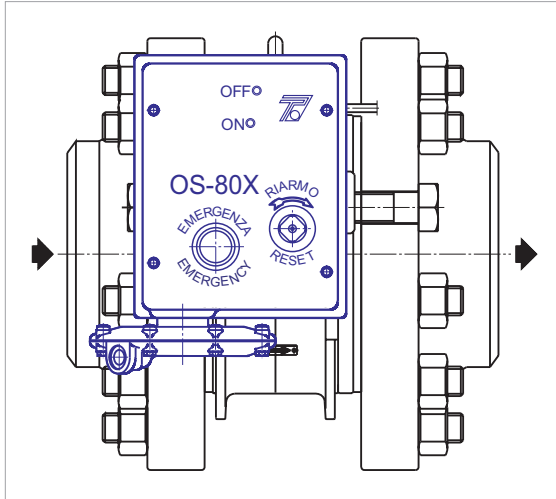

Flow from left to right
Type OS/80X-S-R Clockwise resetting

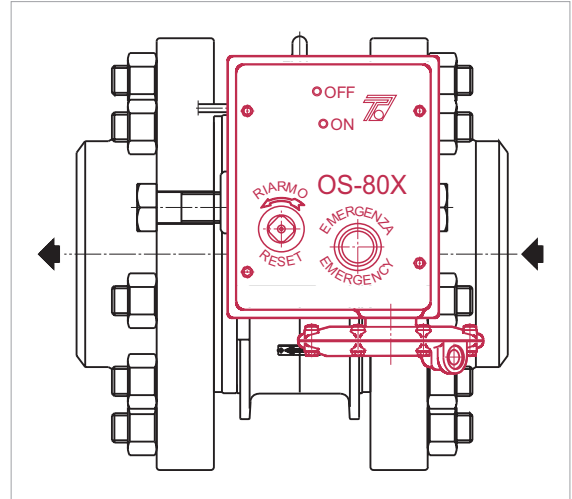

Flow from right to left
Type OS/80X-R Counterclockwise resetting

Off-Center Butterfly Disk Adjusting

In the event of replacement of the Type OS/80X-R or valve disassembly for maintenance work, it is very important to check the level of the "C" height indicated in the following table prior to reinstalling the valve on the line. If necessary, use the respective dowel to adjust the position of the off-center butterfly disk to avoid the occurrence of irregular loads due to the impact of the fluid.

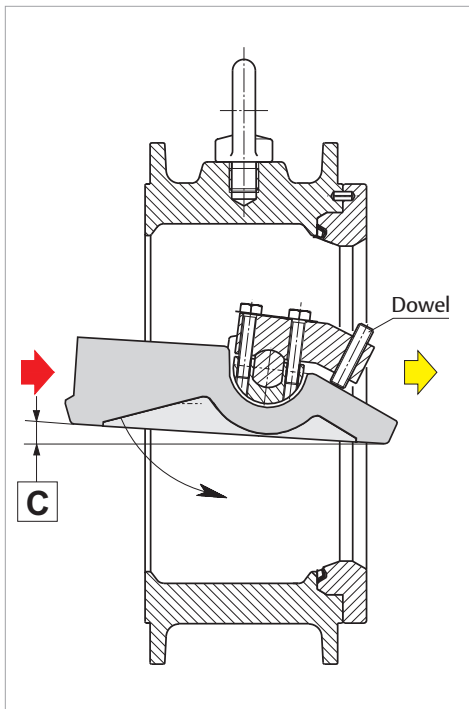

Type	C
BM6X/80	Min. 1 mm - Max. 3 mm
BM6X/100	Min. 1 mm - Max. 5 mm
BM6X/150	Min. 3 mm - Max. 8 mm
BM6X/200	Min. 5 mm - Max. 10 mm
BM6X/250	Min. 6 mm - Max. 11 mm
BM6X/300	Min. 8 mm - Max. 13 mm

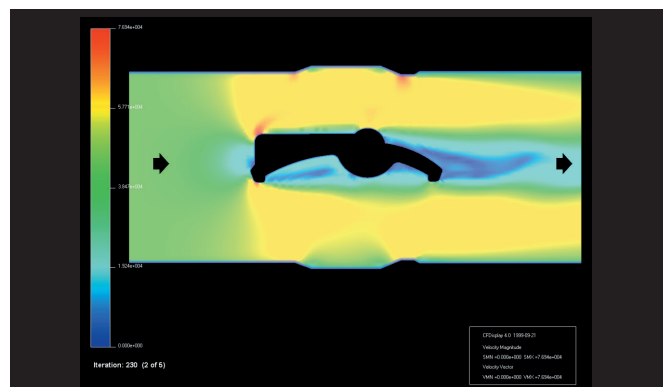

Simulation of the Fluid Mechanics of the Internal Flows

In the event of grit or grime in the lines, it is advisable to install a filter upstream with a filtering capacity of at least 20 microns.

Accessories

Proximity Switch

In order to send the shut-off opening/closing signal, a proximity switch suitable for installation in hazardous area is used.

The use of this switch foresees the application of an intrinsic safety separation barrier which should be installed in safe area.

The distance between the proximity switch and the barrier should be calculated according to the type of gas and installation electrical specifications.

The proximity switch should be positioned at about 0.5 mm from the stem (S).

The adjustment is made by means of adjusting nuts.

On request it is possible to supply the pilot in the version with two proximity switches in order to indicate extreme positions of valve opening/closing.

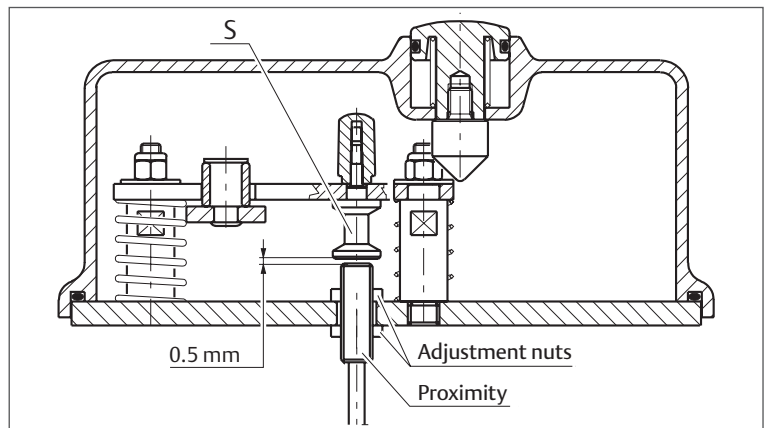

Electrovalve for Remote Controlled Closure

The Types OS/80X-R and OS/80X-R-PN equipped with a shut-off device for minimum pressure, can be equipped with a 3-way valve with explosion proof construction to permit remote controlled closure.

IT/3V Three-Way Valve for Setting Control (P_{umax} 50 bar)

It allows the Type OS/80X-R operation and setting control, without having to change the regulator setting.

The valve is installed on the Type OS/80X-R control line and it must be connected to a suitable pressure source that is capable of reaching the settings of the Type OS/80X-R.

The Type IT/3V three-way valve is of the spring return type and it is equipped with a safety lock plate (B) on the control knob (Q).

When the plate (B) is pivoted, pressure on the knob (Q) makes it possible to put the sensitive member into communication with a pressure source, thus making it possible to perform operation and setting tests.

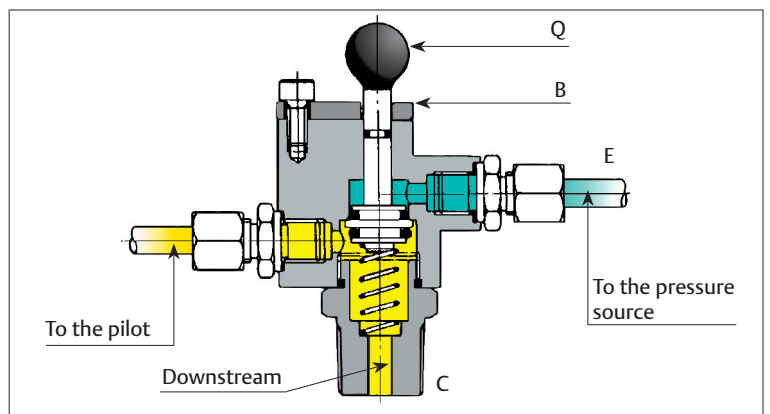
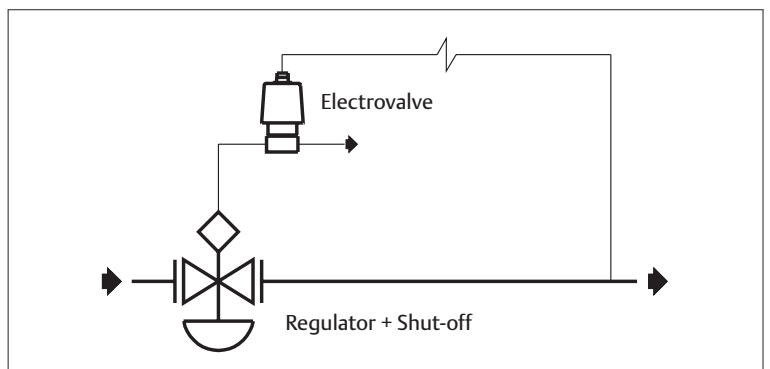

Upon completion of the procedures, releasing the knob will reset normal running conditions. The safety lock plate on the knob prevents accidental maneuvers.

BM6X Slam-Shut Valves

Examples of Connections

Installation in a low pressure regulating line.

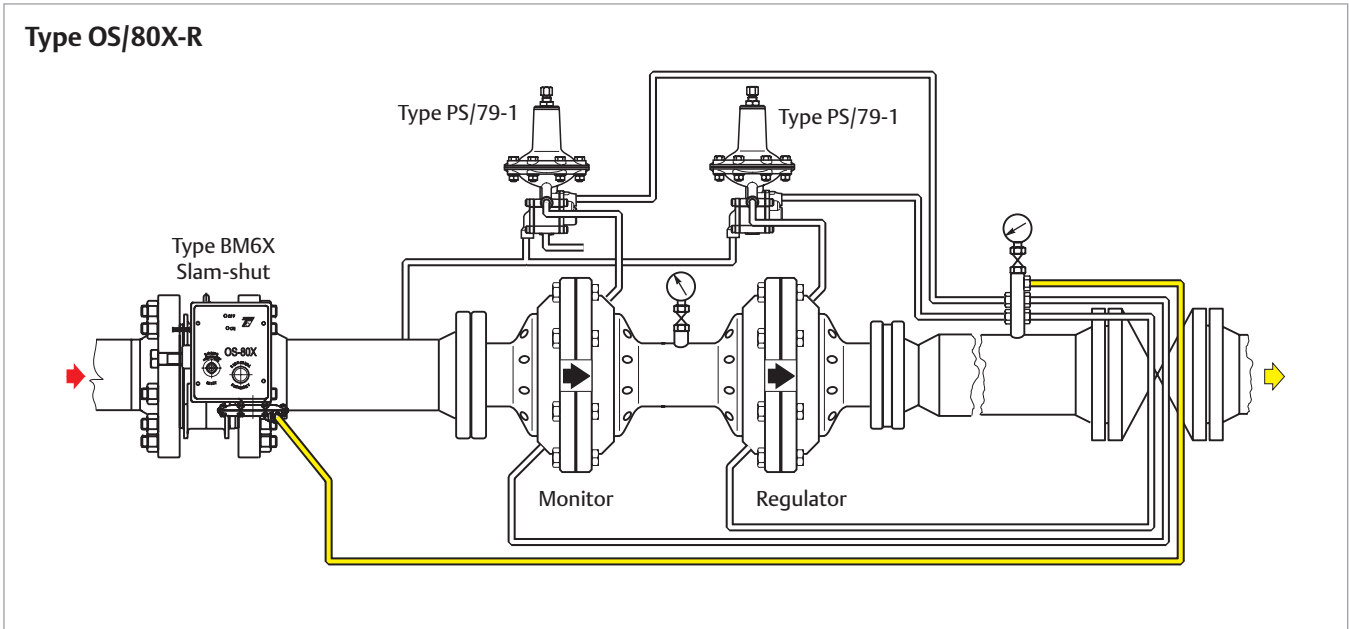

Overpressure and underpressure control downstream of regulators

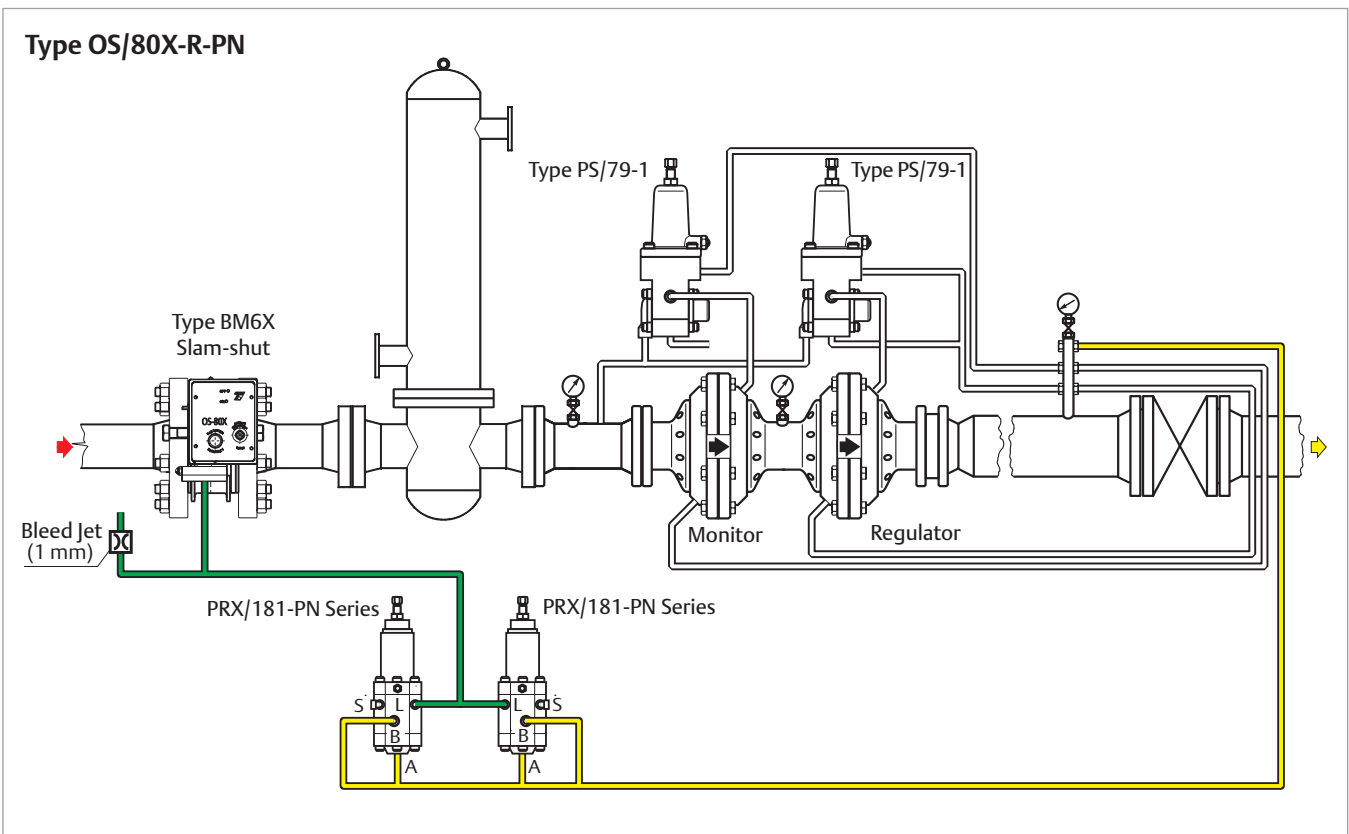

■ Downstream pressure ■ Atmospheric pressure

Overall Dimensions (mm)

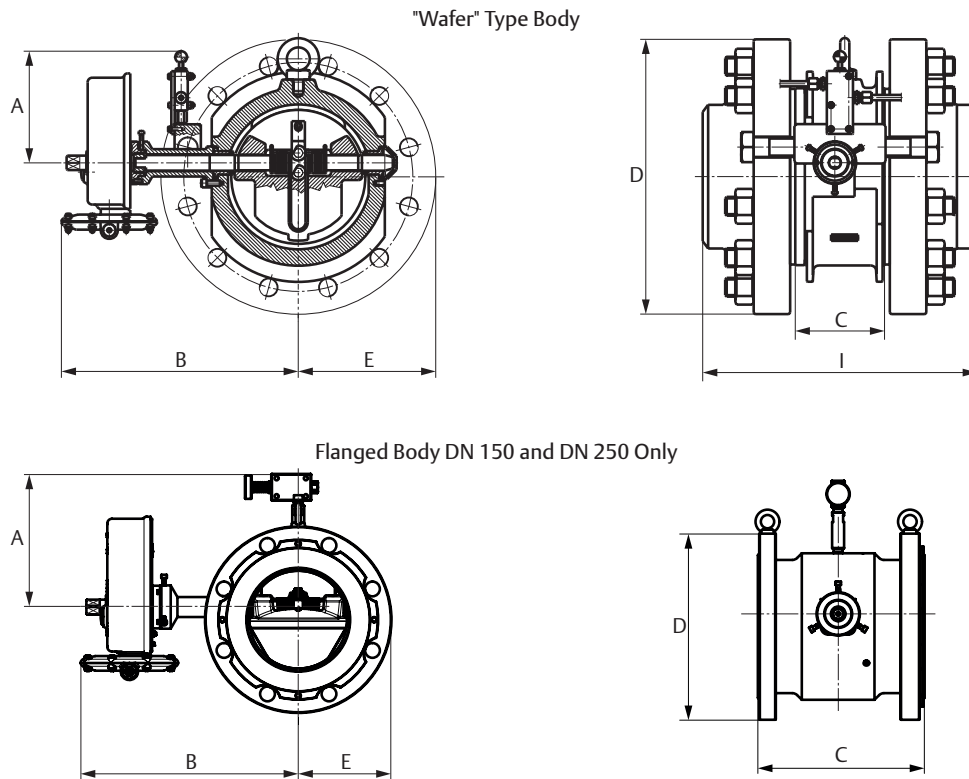

Type	DN 80	DN 100	DN 150	DN 150 Flanged Body	DN 200	DN 250	DN 250 Flanged Body	DN 300
A	155	170	220	205	220	220	277	220
B	250	290	415	330	445	480	418	510
C	54	70	105	250	137	170	320	203
ANSI 150	D	190	230	279	280	343	406	482
	E	95	115	140	140	172	203	241
	I	197	227	287	----	344	377	436
ANSI 300	D	210	254	318	320	381	445	521
	E	105	127	159	160	191	223	261
	I	217	245	306	----	363	409	468
ANSI 600	D	210	274	357	356	419	508	559
	E	105	137	179	178	220	254	280
	I	235	264	357	----	421	492	531

N.B. The B dimensions are indicative and refer to the models with larger dimensions.
The threaded opening for the connection of the control line is 1/4" NPT female.

Weights (kg)

Type	DN 80	DN 100	DN 150	DN 150 Flanged Body	DN 200	DN 250	DN 250 Flanged Body	DN 300
ANSI 150	10	13	22	54	38	71	----	111
ANSI 300			26	73	40	73	----	115
ANSI 600		15	33	95	45	77	230	121

 Webadmin.Regulators@emerson.com

 Tartarini-NaturalGas.com

 Facebook.com/EmersonAutomationSolutions

 LinkedIn.com/company/emerson-automation-solutions

 Twitter.com/emr_automation

Emerson

Americas

McKinney, Texas 75070 USA

T +1 800 558 5853

+1 972 548 3574

Europe

Bologna 40013, Italy

T +39 051 419 0611

Asia Pacific

Singapore 128461, Singapore

T +65 6777 8211

Middle East and Africa

Dubai, United Arab Emirates

T +971 4 811 8100

D104044X012 © 2018, 2024 Emerson Process Management Regulator Technologies, Inc. All rights reserved. 04/24.

The Emerson logo is a trademark and service mark of Emerson Electric Co. All other marks are the property of their prospective owners. Tartarini™ is a mark owned by one of the companies in the Emerson Automation Solutions business unit of Emerson Electric Co.

The contents of this publication are presented for informational purposes only, and while efforts have been made to ensure their accuracy, they are not to be construed as warranties or guarantees, express or implied, regarding the products or services described herein or their use or applicability. All sales are governed by our terms and conditions, which are available on request. We reserve the right to modify or improve the designs or specifications of our products at any time without notice.

Emerson Process Management Regulator Technologies, Inc does not assume responsibility for the selection, use or maintenance of any product. Responsibility for proper selection, use and maintenance of any Emerson Process Management Regulator Technologies, Inc. product remains solely with the purchaser.

O.M.T. Officina Meccanica Tartarini S.R.L.,

Emerson Automation Solutions - Stabilimento di/Site of: Castel Maggiore - Bologna

Sede Legale/Legal Entity: Piazza Meda 5, 20121 Milano, Italy

Sede Amministrativa/Administrative Headquarters: OMT Tartarini, Via Clodoveo Bonazzi 43, 40013 Castel Maggiore (Bologna), Italy C.F. - P.I. e R.I. di MI 13186130152 - REA di MI/n.1622916

Direz. e Coord. (art. 2497 bis CC): EMERSON ELECTRIC CO. St. Louis (USA) Socio Unico

