

**FASANI BOLTED BONNET GATE VALVES**  
WEDGE CONFIGURATION

The bolted bonnet type valves are manufactured to guarantee the highest performance in the widest spectrum of oil and gas applications

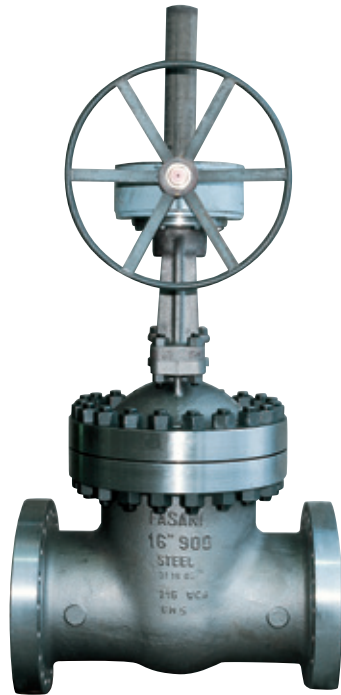

**FEATURES**

- Robust valve body in a wide range of materials (NACE compliance included).
- Threaded seat rings facilitate maintenance and/or replacement. On request, they can also be supplied as tack or seal welded. Above NPS 24, seats are seal welded as standard.
- Yoke sleeve in material suitable to withstand high temperature, wear and corrosion.
- Connections are offered as flanged, buttweld or special, such as clamp type, to meet any customers' request.
- Wedge gate valves designed in full compliance with API 600, ASME B16.34 and BS 1414.

**GENERAL APPLICATION**

These high quality valves are installed in a large variety of services in the oil and gas field, chemical and petrochemical industry, in onshore and offshore drilling/refining, and in the power industry.  
These valves are successfully installed worldwide on applications requiring tight shutoff.

**TECHNICAL DATA**

Sizes: DN 50 to 1500 and larger  
 Temperature [°C]: -60 to + 650  
 Pressure ratings: ASME class 150 to 2500  
 Body materials: Carbon, alloy and stainless steels, duplex steels, special alloys

**Connections standards**

Flanges: ASME B16.5 and B16.47, API 605, MSS-SP 44  
 Butt weld: ASME B16.25

# FASANI BOLTED BONNET GATE VALVES

## WEDGE CONFIGURATION

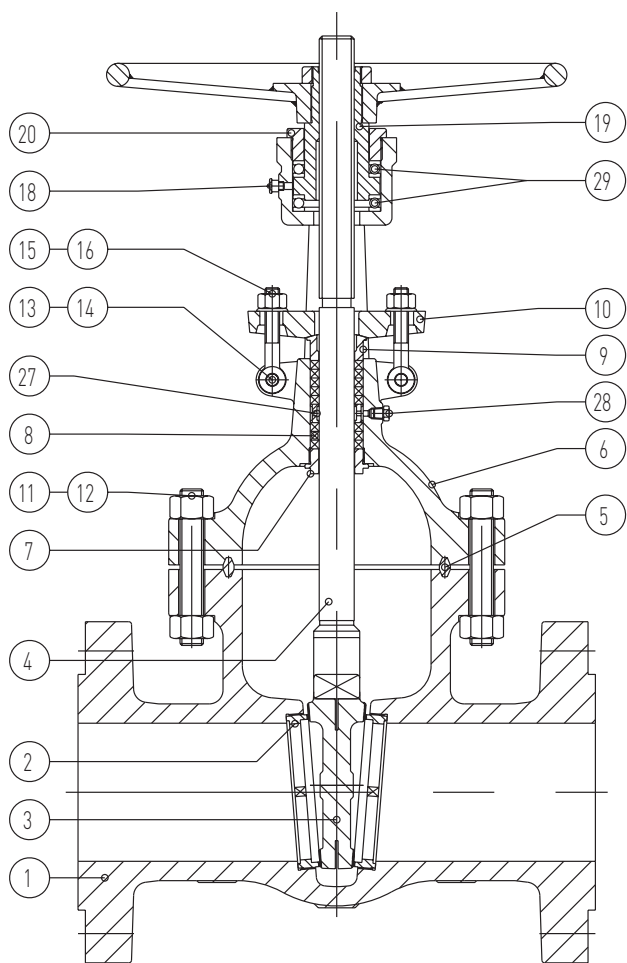

### NOTES

1. Other materials are available on request. Please consult supplier.
2. The item 5 (gasket) is supplied in different versions class 150: flat gasket in reinforced graphite. class 300: spiral wound gasket in 316/graphite. All remaining classes: RTJ in the materials indicated in the material specification.
3. The sectional drawing represented here refers to class 600 and larger.
4. Upon request only.

### MATERIAL SELECTION

Item	Description	Body in WCB	Body in WC6	Body in CF8M
1	Body	A216 WCB	A217 WC6	A351 CF8M
2	Seat ring	A105 + AWS ER 430	A182 F22 + AWS ER 430	A182 F316
3	Gate	A216 WCB + AWS ER 430	A217 WC6 + AWS ER 430	A351 CF8M
4	Stem	A182 F6a	A182 F6a	A182 F316
5	Gasket	Soft iron	A182 F5	A182 F316
6	Bonnet	A216 WCB	A217 WC6	A351 CF8M
7	Backseat	A182 F6a	A182 F6a	A182 F316
8	Packing	Flexible graphite inner rings and suitable anti-extrusion rings		
9	Gland	A182 F6a	A182 F6a	A182 F316
10	Gland flange	A105 or A516 gr. 70	A105 or A516 gr. 70	A182 F316 or A240 Tp. 316
11	Body - bonnet bolt	A193 B7	A193 B16	A193 B8M
12	Body - bonnet nut	A194 2H	A194 4	A194 8
13	Lug bolt	A193 B7	A193 B7	A193 B8
14	Lug nut	A194 2H	A194 2H	A194 8
15	Gland bolt	A193 B7	A193 B7	A193 B8
16	Gland nut	A194 2H	A194 2H	A194 8
18	Lubricator	Steel	Steel	Steel
19	Yoke sleeve	A763 gr. A	A763 gr. A	A763 gr. A
20	Yoke nut bushing	A105	A105	A105
27	Lantern <sup>[4]</sup>	A182 F6a	A182 F6a	A182 F316
28	Drain plug <sup>[4]</sup>	Steel	Steel	Stainless steel
29	Bearings	Steel	Steel	Steel

# FASANI BOLTED BONNET GATE VALVES

## WEDGE CONFIGURATION

PRESSURE/TEMPERATURE RATINGS In barg/psig (ASME B16.34)

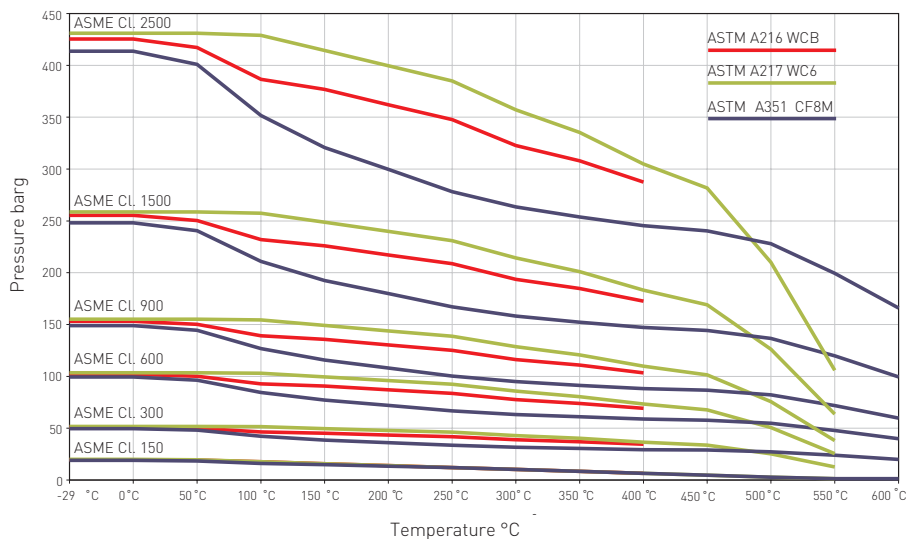

### NOTES

All valves are fully rated in accordance with ASME B16.34. The table represented here indicates the pressure/temperature rating values as per ASME B16.34-1996.

### TRIM

No.	Nominal trim symbol	Material type					Service
		Seal surfaces	Disc/wedge surfaces	Stem hinge pin	Backseat	Small internal parts	
1	CR13	13% Cr	13% Cr	13% Cr	13% Cr	13% Cr	General erosive or non-corrosive service between -100°C and 400°C
2	18-8	304	304	304	304	304	For moderate pressure in non-erosive, corrosive service between -265°C and 320°C
3	25-20	310	310	310	310	310	For moderate pressure in corrosive or non corrosive service. Between -265°C and 450°C
4	SH	Hard 13% Cr	Hard 13% Cr	13% Cr	13% Cr	13% Cr	As trim no. 1 but for medium pressure
5	HF	Co-Cr A	Co-Cr A	13% Cr	13% Cr	13% Cr	High pressure slightly erosive and corrosive service between -265°C and 650°C
5A	HFNi	Ni-Cr	Ni-Cr	13% Cr	13% Cr	13% Cr	As trim no. 5 where Co is not allowed
6	Cr13 Ni-Cu	Ni-Cu	13% Cr	13% Cr	13% Cr	13% Cr	As trim no. 1
7	CR13 SH	Hard 13% Cr	13% Cr	13% Cr	13% Cr	13% Cr	As trim no. 1 but for moderate pressure
8	CR13 HF	Co-Cr A	13% Cr	13% Cr	13% Cr	13% Cr	As trim no. 5 for moderate pressure
8A	CR13 HFNi	Ni-Cr	13% Cr	13% Cr	13% Cr	13% Cr	As trim no. 5A for moderate pressure
9	Ni-Cu	Ni-Cu	Ni-Cu	Ni-Cu	Ni-Cu	Ni-Cu	Very corrosive fluids. Erosive-corrosive service between -240°C and 480°C
10	18-8SMO	316	316	316	316	316	As trim no. 2
11	Ni-Cu HF	Co-Cr A	Ni-Cu	Ni-Cu	Ni-Cu	Ni-Cu	As trim no. 9 but for medium pressure
12	18-8SMO HF	Co-Cr A	316	316	316	316	As trim no. 10 but for medium pressure
13	Alloy 20	19Cr-29Ni	19Cr-29Ni	19Cr-29Ni	19Cr-29Ni	19Cr-29Ni	Very corrosive service. For moderate pressure between -45°C and 320°C
14	Alloy 20 HF	Co-Cr A	19Cr-29Ni	19Cr-29Ni	19Cr-29Ni	19Cr-29Ni	As trim no. 13 but for medium pressure

Co-Cr A is equivalent to Stellite® 6

# FASANI BOLTED BONNET GATE VALVES

## WEDGE CONFIGURATION

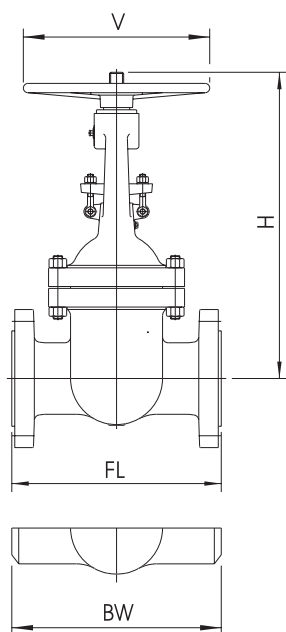

Sizes		ASME class 150 (Fig. VS 150 BB)						ASME class 300 (Fig. VS 300 BB)						ASME class 600 (Fig. VS 600 BB)					
DN	NPS	FL	BW	H	V	W1	W2	FL	BW	H	V	W1	W2	FL	BW	H	V	W1	W2
50	2	178	216	395	200	18	15	216	216	415	200	25	20	292	292	455	250	33	25
65	2½	191	242	475	250	25	23	242	242	490	250	33	28	330	330	570	250	55	45
80	3	203	283	520	250	35	30	283	283	540	250	50	40	356	356	610	300	60	55
100	4	229	305	650	250	50	40	305	305	675	300	80	60	432	432	715	350	115	90
125	5	254	381	740	300	70	60	381	381	830	400	120	105	508	508	870	450	155	120
150	6	267	403	830	300	80	70	403	403	920	400	140	115	559	559	995	500	245	180
200	8	292	419	1065	400	135	120	419	419	1140	450	230	170	660	660	1215	575	420	355
250	10	330	457	1260	450	185	165	457	457	1320	575	315	260	788	788	1510	750	725	590
300	12	356	502	1475	500	280	255	502	502	1580	•	505	425	838	838	1720	750	945	820
350	14	381	572	1640	575	395	350	762	762	1920	•	765	650	889	889	1970	•	1210	1150
400	16	407	610	1960	•	530	500	838	838	2085	•	1005	870	991	991	2040	•	1765	1550
450	18	432	660	2130	•	670	650	914	914	2460	•	1205	1090	1092	1092	2120	•	1970	1750
500	20	457	711	2460	•	775	750	991	991	2635	•	1685	1545	1194	1194	2185	•	2420	2075
550	22	-	762	2600	•	-	950	-	1093	2760	•	-	1740	-	1296	2570	•	-	2835
600	24	508	813	2755	•	1150	1010	1143	1143	2895	•	2400	2085	1397	1397	2715	•	3720	3400
650	26	559	813	2935	•	*	1400	1245	1245	3100	•	*	2540	1448	1448	2960	•	*	4200
700	28	610	610	3135	•	*	1500	1346	1346	3290	•	*	2980	1549	1549	3260	•	*	5000
750	30	610	610	3400	•	*	1770	1397	1397	3520	•	*	3675	1651	1651	3550	•	*	5800
800	32	660	660	3480	•	*	2050	1524	1524	3700	•	*	4100	1778	1778	3700	•	*	6770
850	34	711	711	3950	•	*	2410	1626	1626	3950	•	*	5440	1930	1930	3845	•	*	7740
900	36	711	711	4055	•	*	2940	1727	1727	4205	•	*	6320	2083	2083	3990	•	*	8700
950	38	-	-	-	•	*	-	-	-	-	•	*	-	-	-	-	•	*	-
1000	40	762	762	4355	•	*	3710	1930	1930	4530	•	*	8400	2286	2286	4490	•	*	11750
1050	42	813	813	4700	•	*	4200	1981	1981	4685	•	*	9450	2438	2438	4735	•	*	13250
1100	44	-	-	-	•	*	-	-	-	-	•	*	-	-	-	-	•	*	-
1150	46	-	-	-	•	*	-	-	-	-	•	*	-	-	-	-	•	*	-
1200	48	914	914	5090	•	*	5600	2235	2235	5195	•	*	12150	2540	2540	4900	•	*	17400

• BGO

### NOTES

- All dimensions are in mm.
- Gate valves in sizes and classes larger than mentioned here are available. Please consult supplier for more information.
- Dim. H corresponds to the height of valve in open position.
- BGO stands for "Bevel Gear Operator".
- W1 corresponds to weight in kilos for flanged body style.
- \* For sizes larger than NPS 24, weight depends on flange standards.
- W2 corresponds to weight in kilos for welding body style.

# FASANI BOLTED BONNET GATE VALVES

## WEDGE CONFIGURATION

Sizes		ASME class 900 (Fig. VS 900 BB)						ASME class 1500 (Fig. VS 1500 BB)						ASME class 2500 (Fig. VS 2500 BB)					
DN	NPS	FL	BW	H	V	W1	W2	FL	BW	H	V	W1	W2	FL	BW	H	V	W1	W2
50	2	-	-	-	-	-	-	368	368	570	350	70	60	451	451	590	400	150	115
65	2½	-	-	-	-	-	-	419	419	665	350	135	110	508	508	685	400	230	170
80	3	381	381	650	400	130	110	470	470	740	500	160	125	578	578	720	500	260	200
100	4	458	458	780	500	210	180	546	546	790	575	265	215	673	673	865	575	400	330
125	5	-	-	-	-	-	-	-	-	-	-	-	-	-	-	-	-	-	-
150	6	610	610	1055	575	380	295	705	705	1170	650	560	500	914	914	1140	750	930	680
200	8	737	737	1295	750	635	515	832	832	1380	750	1040	820	1022	1022	1270	900	1505	1150
250	10	838	838	1520	750	1035	870	991	991	1510	900	1650	1370	1270	1270	1560	•	2800	2100
300	12	965	965	1740	•	1395	1180	1130	1130	1820	•	2485	2050	1422	1422	1660	•	3480	2600
350	14	1029	1029	1910	•	1780	1565	1257	1257	1980	•	3100	2650	-	-	-	•	-	-
400	16	1130	1130	1950	•	2165	1915	1384	1384	2100	•	3705	3050	-	-	-	•	-	-
450	18	1219	1219	2150	•	3200	2340	1537	1537	2300	•	5085	4150	-	-	-	•	-	-
500	20	1321	1321	2345	•	3540	2740	1664	1664	2580	•	6400	5100	-	-	-	•	-	-
550	22	-	-	-	•	-	-	-	-	-	•	-	-	-	-	-	•	-	-
600	24	1550	1550	2880	•	5760	4810	1943	1943	2850	•	10300	8670	-	-	-	-	-	-

• BGO

### NOTES

- All dimensions are in mm.
- Gate valves in sizes and classes larger than mentioned here are available. Please consult supplier for more information.
- Dim. H corresponds to the height of valve in open position.
- BGO stands for "Bevel Gear Operator".
- W1 corresponds to weight in kilos for flanged body style.
- \* For sizes larger than NPS 24, weight depends on flange standards.
- W2 corresponds to weight in kilos for welding body style.

# FASANI BOLTED BONNET GATE VALVES

## WEDGE CONFIGURATION

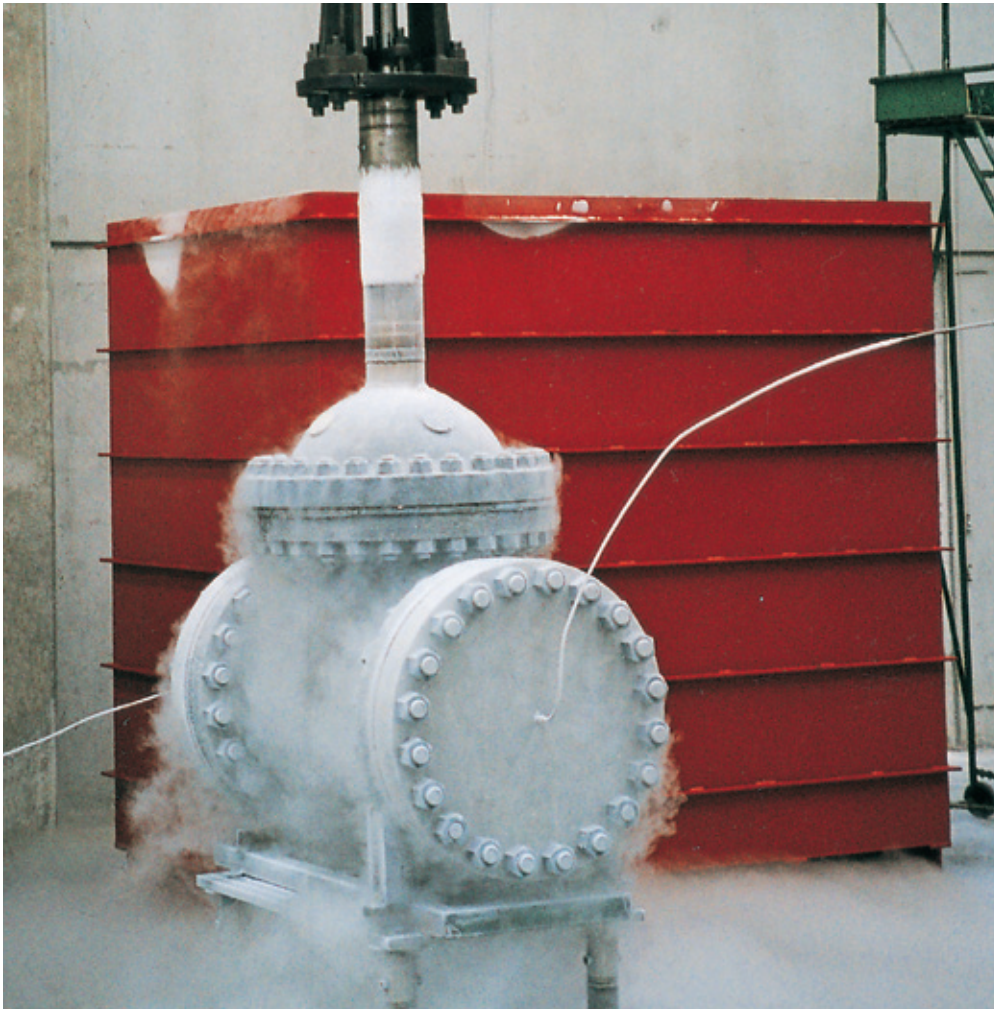

### GENERAL APPLICATION

The cryogenic valves are widely installed on applications involving media at extremely low temperatures, such as the production, storage and transportation of liquefied natural gas, hydrogen, oxygen, etc.

### TECHNICAL DATA

Sizes: DN 50 to 600 and larger  
Temperature [°C]: Down to -254  
Pressure ratings: From ASME 150 to 900  
Body materials: CF8M, CF8, and other low temperature steels

### Connections standards

Flanges: ASME B16.5  
Buttweld: ASME B16.25

### FEATURES

The cryogenic valves face the harsh conditions of services involving temperatures down to -254°C.

- Body in a range of materials suitable for extremely low temperatures, such as CF8M, CF8 and other very low temperature steels.
- The extended bonnet of gate valves completely eliminates any chance of frosting in the packing area.
- The presence of a bleed hole in the gate valve wedge helps equalize the body cavity pressure with the up-stream pressure.
- Connections are offered as flanged or special.
- All cryogenic valves are designed in full compliance with ASME B16.34 and BS 6364.
- The cryogenic tests are performed in the fully equipped in-house facilities, according to BS 6364 and all major oil and gas cryogenic test procedures.
- Seats are welded in.

# FASANI BOLTED BONNET GATE VALVES

## WEDGE CONFIGURATION

### MATERIAL SELECTION

Item	Description	Body in CF8	Body in CF8M
1	Body	A351 CF8	A351 CF8M
2	Seat ring	A182 F316 + Stellite®	A182 F316 + Stellite®
3	Gate	A351 CF8 + Stellite®	A351 CF8M + Stellite®
4	Stem	A182 F304	A182 F316
5	Gasket	Spiral wound 316/Graphite	Spiral wound 316/Graphite
6	Bonnet	A351 CF8	A351 CF8M
6.1	Extension bonnet	A182 F304	A182 F316
7	Backseat	A182 F304	A182 F316
8	Packing	Flexible graphite inner rings and suitable anti-extrusion rings	
9	Gland	A182 F304	A182 F316
10	Gland flange	A182 F316 or A240 Tp. 316	A182 F316 or A240 Tp. 316
11	Body - bonnet bolt	A320 B8	A320 B8M
12	Body - bonnet nut	A194 8	A194 8
15	Gland bolt	A193 B8	A193 B8
16	Gland nut	A194 8	A194 8
18	Lubricator	Steel	Steel
19	Yoke sleeve	A763 gr. A	A763 gr. A
20	Yoke nut bushing	A105	A105
27	Lantern*	A182 F304	A182 F316
28	Drain plug*	Stainless steel	Stainless steel
175	Relief plug	Stainless steel	Stainless steel

\* upon request only

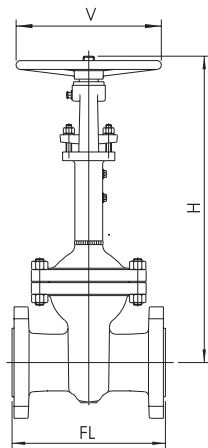
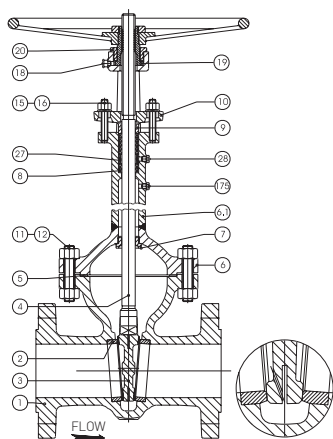

### NOTES

1. All dimensions are in mm.
2. Gate Cryogenic valves in sizes and classes larger than mentioned here are available. Please consult supplier for more information.
3. Dim. H corresponds to the height of valve in open position.
4. BGO stands for "Bevel Gear Operator".
5. "W" corresponds to weight in kilos (flanged body style).

Sizes	DN	NPS	ASME class 150 (Fig. VSC 150 BB)				ASME class 300 (Fig. VSC 300 BB)				ASME class 600 (Fig. VSC 600 BB)				ASME class 900 (Fig. VSC 900 BB)			
			FL	H	V	W	FL	H	V	W	FL	H	V	W	FL	H	V	W
	50	2	178	895	400	22	216	915	400	28	292	955	500	42	-	-	-	-
	65	2½	191	925	400	33	242	940	400	40	-	-	-	-	-	-	-	-
	80	3	203	1020	400	40	283	1040	500	55	356	1110	600	70	381	700	700	140
	100	4	229	1150	500	60	305	1175	600	85	432	1215	700	130	458	820	800	225
	125	5	-	-	-	-	-	-	-	-	-	-	•	-	-	-	•	-
	150	6	267	1280	600	90	403	1370	700	150	559	1445	•	270	610	1545	•	405
	200	8	292	1565	700	145	419	1640	800	240	660	1765	•	480	737	1795	•	685
	250	10	330	1760	800	205	457	1820	•	335	788	2150	•	790	838	2020	•	1100
	300	12	356	1975	•	305	502	2130	•	525	838	2345	•	1025	965	2240	•	1475
	350	14	381	2375	•	445	762	2470	•	790	889	2565	•	1290	1029	2510	•	1860
	400	16	407	2510	•	560	838	2635	•	1035	991	2820	•	1850	1130	2550	•	2250
	450	18	432	2730	•	705	914	3010	•	1240	1092	2840	•	2080	1219	2850	•	3310
	500	20	457	3060	•	805	991	3185	•	1720	1194	3115	•	2590	1321	3045	•	3710
	550	22	-	-	•	-	-	-	•	-	-	-	•	-	-	-	•	-
	600	24	508	3355	•	1185	1143	3495	•	2440	1397	3575	•	3865	1550	3630	•	5900

• BGO

Neither Emerson, Emerson Automation Solutions, nor any of their affiliated entities assumes responsibility for the selection, use or maintenance of any product. Responsibility for proper selection, use, and maintenance of any product remains solely with the purchaser and end user.

Fasani is a mark owned by one of the companies in the Emerson Automation Solutions business unit of Emerson Electric Co. Emerson Automation Solutions, Emerson and the Emerson logo are trademarks and service marks of Emerson Electric Co. All other marks are the property of their respective owners.

The contents of this publication are presented for informational purposes only, and while every effort has been made to ensure their accuracy, they are not to be construed as warranties or guarantees, express or implied, regarding the products or services described herein or their use or applicability. All sales are governed by our terms and conditions, which are available upon request. We reserve the right to modify or improve the designs or specifications of such products at any time without notice.

[Emerson.com/FinalControl](http://Emerson.com/FinalControl)