



# Types C471 and C477 Jet Bleed Internal™ Valves

## Introduction

Types C477 and C471 Jet Bleed Internal™ Valves are designed to provide rapid equalization of tank pressure and downstream line pressure, providing a fast valve response time for quick valve opening. These may be used as primary shutoff valves, excess flow valves, and back check valves for Propane, Butane, and NH<sub>3</sub> (anhydrous ammonia) transfers between stationary bulk storage tanks and mobile transports for fill or delivery applications of liquid or vapor gas, and on in-line applications. The valves can be used in installations with or without pumps and compressors. Non Underwriters Laboratories (UL®) listed types are available with a variety of trim types and body styles and can be used on other compressed gases, but the user should check with the factory to make sure the valves are suitable for the particular service. Actuation of the valve can be achieved manually, by cable, or with a pneumatic actuator.

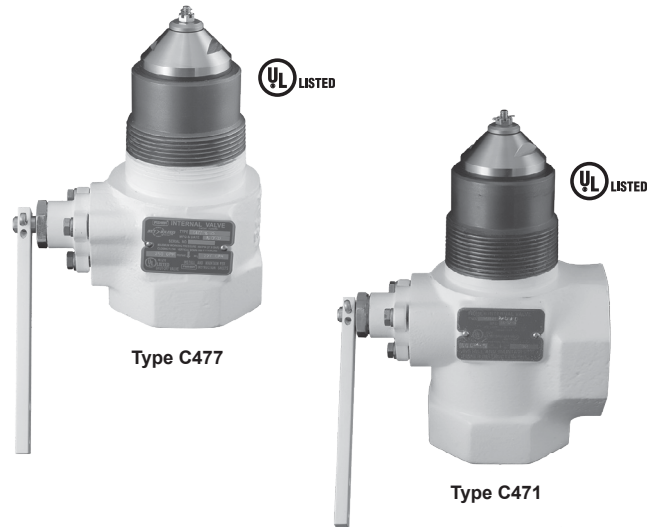

Figure 1. Types C471 and C477 Jet Bleed Internal™ Valves

## Features

- **Patented rapid equalization bleed area** – Provides fast valve response for quick opening.
- **Unique Serviceability Features** – Stainless trim parts and poppet designed with integral wrench flat for easy maintenance.
- **Durable Design** – Stainless poppet and stem interface smoothly for a long wear life.
- **Excess Flow Closure** – Functions when flow exceeds the valves rated capacity or piping is sheared off at the valve.
- **Back Check Feature** – Allows reverse flow, fill with or without actuator device in valve open position.
- **Spring loaded Polytetrafluoroethylene (PTFE) stub shaft packing.**
- **PTFE wear pads Rulon® Bushings at critical wear points**
- **Manual, Cable, or Air Open/Close valve actuators.**
- **Thermal Fusible links or plugs melt at 212 to 220°F / 100 to 104°C and allow valve closure in the event of a fire at the valve.**

Rulon® is a Trademark of Saint-Gobain Performance Plastics Corporation.



[www.fisherregulators.com](http://www.fisherregulators.com)



# Bulletin LP-7:C471/C477

## Specifications

### Body Size and End Connection Style

**Inlet:** 2 or 3-inch MNPT / DN 50 or 80  
**Outlet:** 2 or 3-inch FNPT / DN 50 or 80

### Number of Outlets

**Type C471:** 2 (side and straight through)  
**Type C477:** 1 (straight through)

### Excess Flow Springs

#### Half Coupling Flows:

*2-inch Sizes / DN 50:* 105, 150, and 250 GPM /  
 397, 567, and 946 L/min  
*3-inch Sizes / DN 80:* 160, 265, 375, and 460 GPM /  
 605, 1003, 1419, and 1741 L/min

#### Full Coupling Flows:

*2-inch Sizes / DN 50:* 60, 80, and 130 GPM /  
 227, 302, and 492 L/min  
*3-inch Sizes / DN 80:* 120, 230, 320, and 380 GPM /  
 454, 870, 1211, and 1438 L/min

### Maximum Allowable Inlet Pressure<sup>(1)</sup>

400 psig / 27.6 bar WOG

### Temperature Capabilities<sup>(1)(2)</sup>

-20 to 150°F / -29 to 66°C

### Construction Materials

|  |  |
|--|--|
| <b>Steel</b>   | Body and Operating Lever   |
| <b>Stainless steel</b>                                       | Stem Assembly, Excess Flow Spring, Spring Seat, Closing Spring, Disc Holder, Disc Retainer, Screw, O-ring Seat, O-ring Retainer, Cotter Pin, Spring, Shaft, Screen, Travel Stop, Screen Cap, Bolt, Gasket, and Lock Washer |
| <b>Plated steel</b>  | Nut, Washer, Bonnet Nut, Guide Bracket, and Cap Screw  |
| <b>Polyurethane</b>  | Rod Wiper  |
| <b>PTFE</b>  | Bushing, Packing Adaptor, and Packing Ring   |
| <b>Nitrile (NBR) (Standard Construction)</b>                 | Main Disc and Bleed Disc   |
| <b>Other Disc and O-ring Material Available from Factory</b> | PTFE, Fluorocarbon (FKM), Neoprene (CR), Ethylene-Propylene (EPDM), and Kalrez®  |

### Closing Flow and Vapor Capacity

See Table 2

### Approximate Weights

#### 2-inch Sizes / DN 50:

*Type C471:* 11 pounds / 5 kg  
*Type C477:* 9 pounds / 4 kg

#### 3-inch Sizes / DN 80:

*Type C471:* 21 pounds / 10 kg  
*Type C477:* 16 pounds / 7 kg

1. The pressure/temperature limits in this Bulletin and any applicable standard or code limitation should not be exceeded.

2. Product has passed Fisher® testing for leakage down to -40°F / -40°C.

Kalrez® is a mark owned by E.I. du Pont de Nemours and Co.

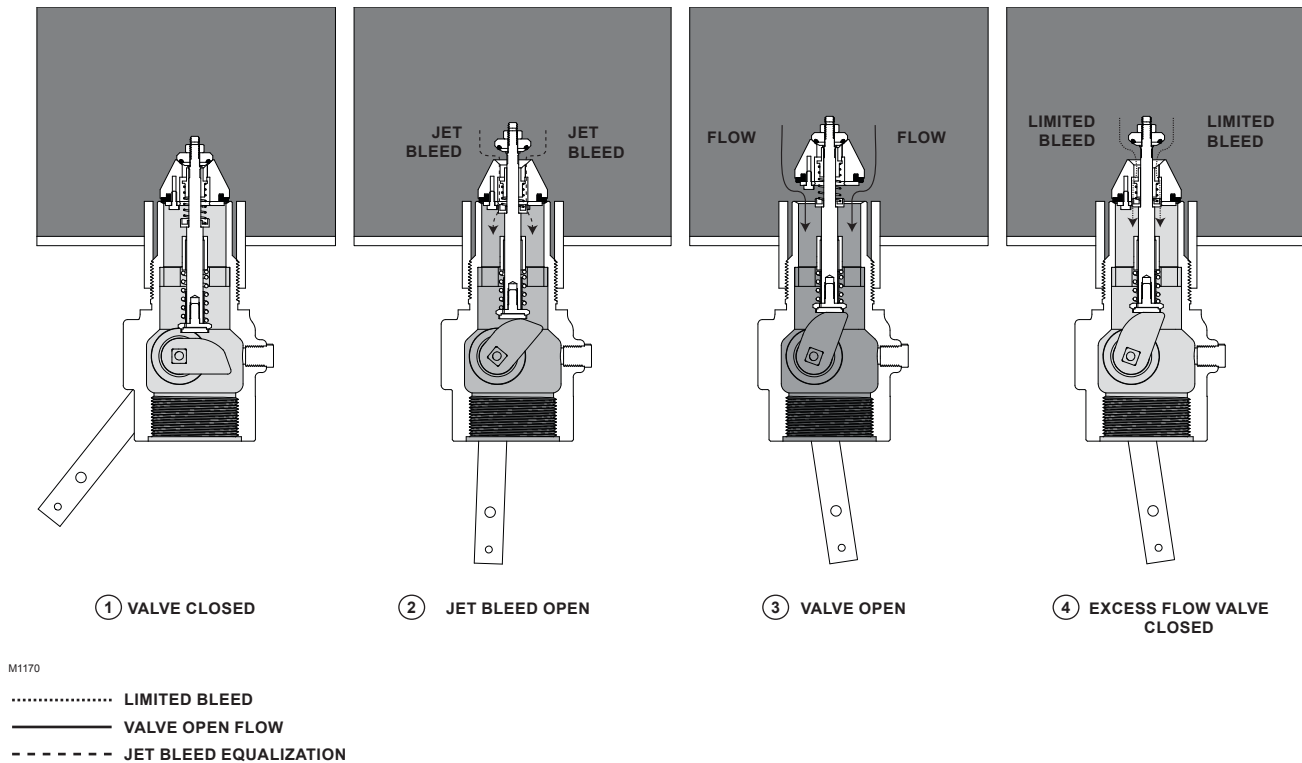

Figure 2. Typical Operational Schematic

## Principle of Operation

Refer to the operational schematic, Figure 2. In view #1, the valve is held closed by both tank pressure and the valve's closing spring. There is no leakage past the resilient seats in the poppet to the valve outlet. The valve is opened by moving the operating lever to approximately midpoint in its 70° travel (view #2). This allows the cam to place the rapid equalization portion of the valve stem in the pilot opening, permitting a larger amount of product to bleed downstream than if the operating lever were moved to the full open position. When tank and downstream pressure are nearly equal after a few seconds, the excess flow spring pushes open the main poppet (view #3) and the operating lever can be moved to the full open position.

### Note

**If tank pressure is greater than the valve's outlet pressure, the main poppet will remain in the closed position. If valve outlet piping**

**is closed off by other valves, however, product bleeding through the pilot will increase until it nearly equals tank pressure and the main poppet opens. The main poppet will not open if valve outlet piping is not closed off so that the outlet pressure can approach tank pressure.**

Once the main poppet opens, a flow greater than the valve's excess flow spring rating or a sufficient surge in flow forces the main poppet closed against the excess flow spring (view #4). The pilot valve allows a small amount of product to bleed, but much less than view #2 where the rapid equalization portion of the stem is placed in the pilot opening. When the operating lever is moved to the closed position, the valve closes completely and seals tightly (view #1).

# Bulletin LP-7:C471/C477

|   |  | MODEL NUMBER |          |          |          |          | SIZE          | SPRING RATE |
|---|--|--------------|----------|----------|----------|----------|---------------|-------------|
| <b>EXAMPLE:</b>   |  | <b>C</b>     | <b>4</b> | <b>7</b> | <b>1</b> | <b>N</b> | - <b>24</b> - | <b>26</b>   |
| <b>Symbol Description</b>   |  |              |          |          |          |          |               |             |
| <b>C</b>  | Product Family   |              |          |          |          |          |               |             |
| <b>4</b>  | UL® Listed   |              |          |          |          |          |               |             |
| <b>8</b>  | Non UL® Listed   |              |          |          |          |          |               |             |
| <b>7</b>  | Ductile Iron Body  |              |          |          |          |          |               |             |
| <b>8</b>  | Steel Body   |              |          |          |          |          |               |             |
| <b>9</b>  | Stainless Body   |              |          |          |          |          |               |             |
| <b>7</b>  | Straight Through Flow  |              |          |          |          |          |               |             |
| <b>3</b>  | Double Flanged Body  |              |          |          |          |          |               |             |
| <b>4</b>  | Single Flanged Body  |              |          |          |          |          |               |             |
| <b>1</b>  | Tee Body (Flanged and NPT)   |              |          |          |          |          |               |             |
|   | Nitrile (NBR) ( <b>Standard</b> , Only Nitrile (NBR) has UL® Approval) |              |          |          |          |          |               |             |
| <b>V</b>  | Fluorocarbon (FKM) Trim  |              |          |          |          |          |               |             |
| <b>T</b>  | PTFE Trim  |              |          |          |          |          |               |             |
| <b>N</b>  | Neoprene (CR) Trim   |              |          |          |          |          |               |             |
| <b>S</b>  | Stainless Steel Body/Gland*  |              |          |          |          |          |               |             |
| <b>M</b>  | Manual Latch Factory Installed   |              |          |          |          |          |               |             |
| <b>ST</b>   | Stainless steel Gland and PTFE Trim                                    |              |          |          |          |          |               |             |
| <b>10</b>   | 1-1/4-Inch / DN 32   |              |          |          |          |          |               |             |
| <b>16</b>   | 2-Inch / DN 50   |              |          |          |          |          |               |             |
| <b>24</b>   | 3-Inch / DN 80   |              |          |          |          |          |               |             |
| <b>32</b>   | 4-Inch / DN 100  |              |          |          |          |          |               |             |
| <b>10</b>   | 105 GPM / 397 L/min  |              |          |          |          |          |               |             |
| <b>15</b>   | 150 GPM / 568 L/min  |              |          |          |          |          |               |             |
| <b>16</b>   | 160 GPM / 606 L/min  |              |          |          |          |          |               |             |
| <b>22</b>   | 220 GPM / 833 L/min  |              |          |          |          |          |               |             |
| <b>25</b>   | 250 GPM / 946 L/min  |              |          |          |          |          |               |             |
| <b>26</b>   | 265 GPM / 1003 L/min   |              |          |          |          |          |               |             |
| <b>37</b>   | 375 GPM / 1419 L/min   |              |          |          |          |          |               |             |
| <b>46</b>   | 460 GPM / 1741 L/min   |              |          |          |          |          |               |             |
| <p>* The Type C891 has Stainless steel body as Standard. 'S' callout on a Type C891 stands for a Stainless steel Gland.<br/>           For each product family, not all options are available. To check the availability of type numbers specified above, contact or visit your local LP-Gas Equipment distributor.</p> |  |              |          |          |          |          |               |             |

Figure 3. Fisher® Internal Valve Numbering System

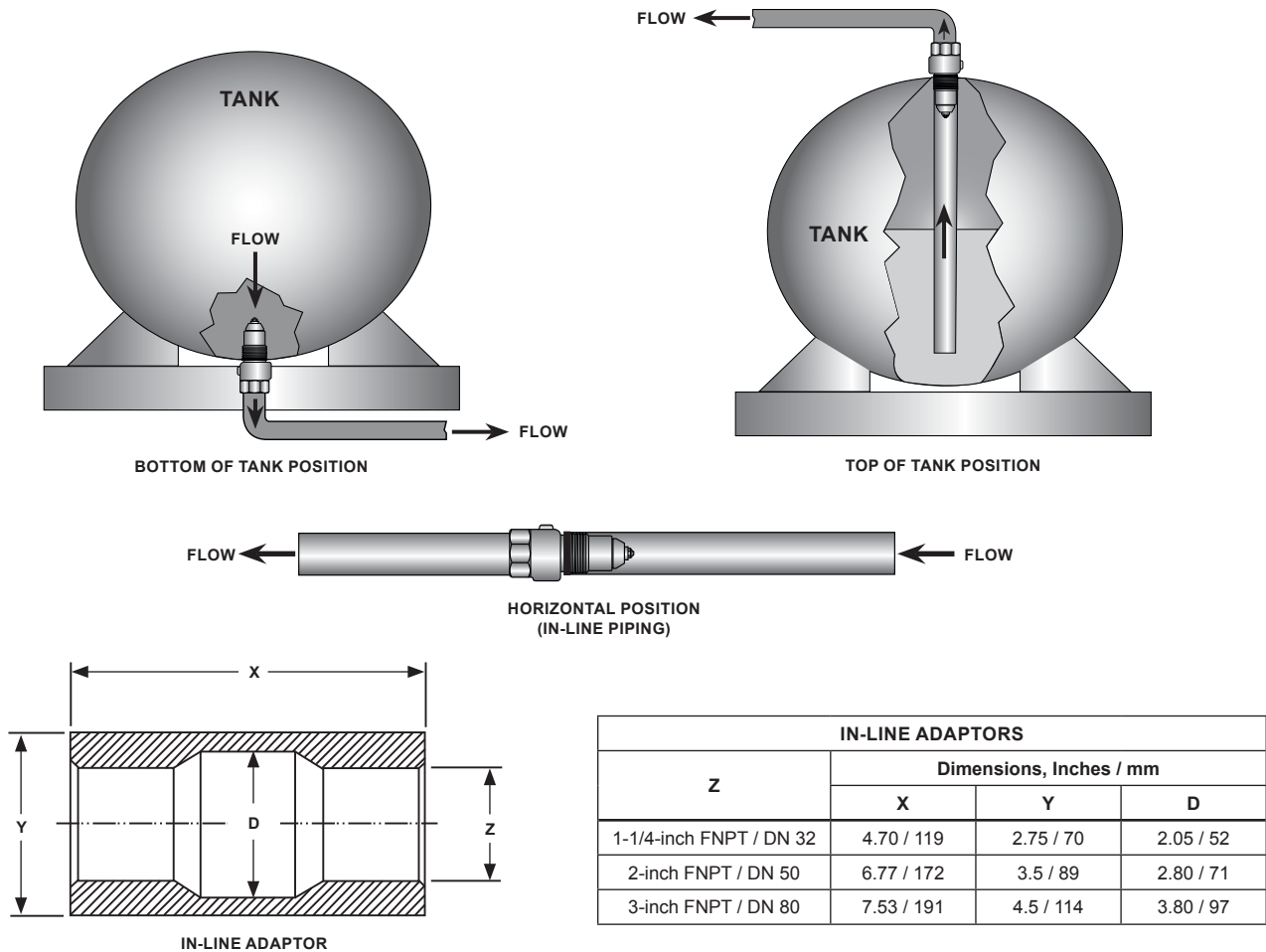

Figure 4. Internal Valve Flow Positions

Table 1. Closing Flow - Propane and NH<sub>3</sub>

| SIZE           | TYPE NUMBER   |            | CLOSING FLOW GPM / L/min PROPANE        |   |                                      | CLOSING FLOW GPM / L/min NH <sub>3</sub> |
|----------------|---------------|------------|---|---|--------------------------------------|--|
|                | Straight Body | Tee Body   | Half Coupling, Bottom of Tank Position* | Full Coupling, Bottom of Tank Position* | Half Coupling, Top of Tank Position* | Half Coupling, Bottom of Tank Position*  |
| 2-inch / DN 50 | C477-16-10    | C471-16-10 | 105 / 397                               | 60 / 227                                | 120 / 454                            | 95 / 360                                 |
|                | C477-16-15    | C471-16-15 | 150 / 568                               | 80 / 303                                | 170 / 643                            | 135 / 511                                |
|                | C477-16-25    | C471-16-25 | 250 / 946                               | 130 / 492                               | 250 / 946                            | 226 / 855                                |
| 3-inch / DN 80 | C477-24-16    | C471-24-16 | 160 / 606                               | 120 / 454                               | 180 / 681                            | 145 / 549                                |
|                | C477-24-26    | C471-24-26 | 265 / 1003                              | 230 / 871                               | 290 / 1098                           | 239 / 905                                |
|                | C477-24-37    | C471-24-37 | 375 / 1419                              | 320 / 1211                              | 395 / 1495                           | 339 / 1283                               |
|                | C477-24-46    | C471-24-46 | 460 / 1741                              | 380 / 1438                              | 460 / 1741                           | 415 / 1571                               |

\* See Internal Valve Flow Positions (Figure 4) for description of Bottom of Tank, Top of Tank, and Horizontal Flow Positions.

Table 2. Closing Flow and Vapor Capacity

| SIZE           | STYLE         |            | VAPOR CAPACITY SCFH / SCMh PROPANE                  |   |  |
|----------------|---------------|------------|---|---|--|
|                | Straight Body | Tee Body   | 100 psig / 6.90 bar Inlet, Bottom of Tank Position* | 100 psig / 6.90 bar Inlet, Horizontal Position* | 100 psig / 6.90 bar Inlet, Top of Tank Position* |
| 2-inch / DN 50 | C477-16-10    | C471-16-10 | 45,000 / 1274                                       | 49,000 / 1388                                   | 66,000 / 1869                                    |
|                | C477-16-15    | C471-16-15 | 69,000 / 1954                                       | 69,000 / 1954                                   | 88,000 / 2492                                    |
|                | C477-16-25    | C471-16-25 | NOT LISTED  | NOT LISTED                                      | NOT LISTED                                       |
| 3-inch / DN 80 | C477-24-16    | C471-24-16 | 71,000 / 2011                                       | 71,000 / 2011                                   | 96,000 / 2718                                    |
|                | C477-24-26    | C471-24-26 | 127,000 / 3596                                      | 127,000 / 3596                                  | 148,000 / 4191                                   |
|                | C477-24-37    | C471-24-37 | 178,000 / 5040                                      | 178,000 / 5040                                  | 186,000 / 5267                                   |
|                | C477-24-46    | C471-24-46 | NOT LISTED  | NOT LISTED                                      | NOT LISTED                                       |

\* See Internal Valve Flow Positions (Figure 4) for description of Bottom of Tank, Top of Tank, and Horizontal Flow Positions.

# Bulletin LP-7:C471/C477

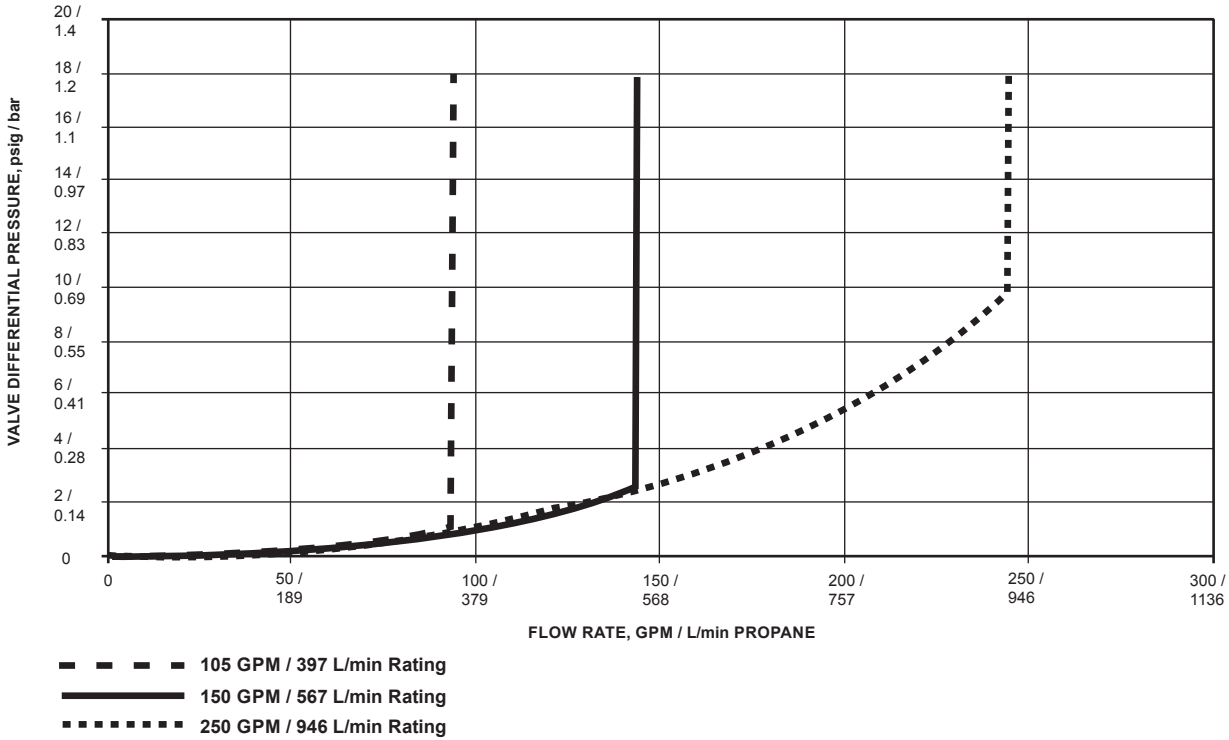

Figure 5. Type C477/471-16 Bottom of Tank Position Flow Curve, Half Coupling

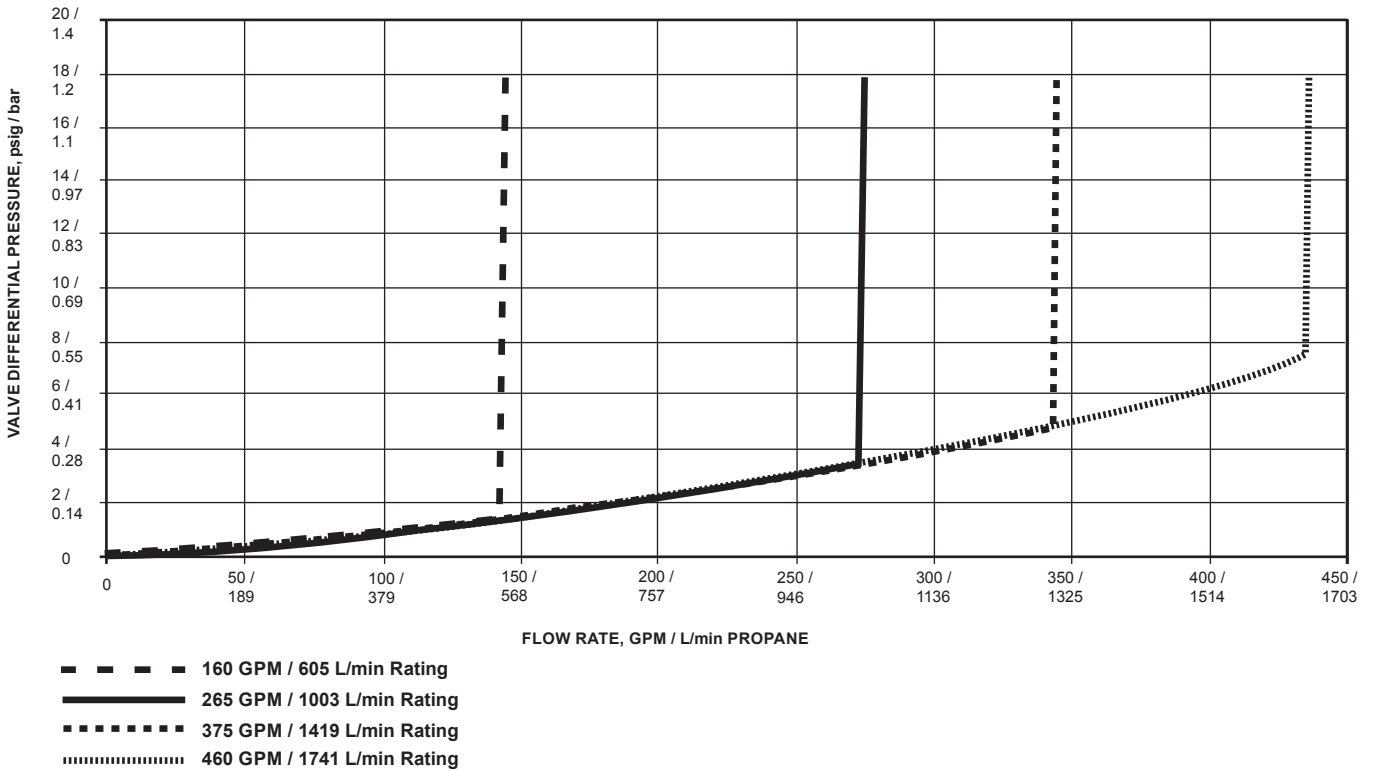

Figure 6. Type C477/471-24 Bottom of Tank Position Flow Curve, Half Coupling

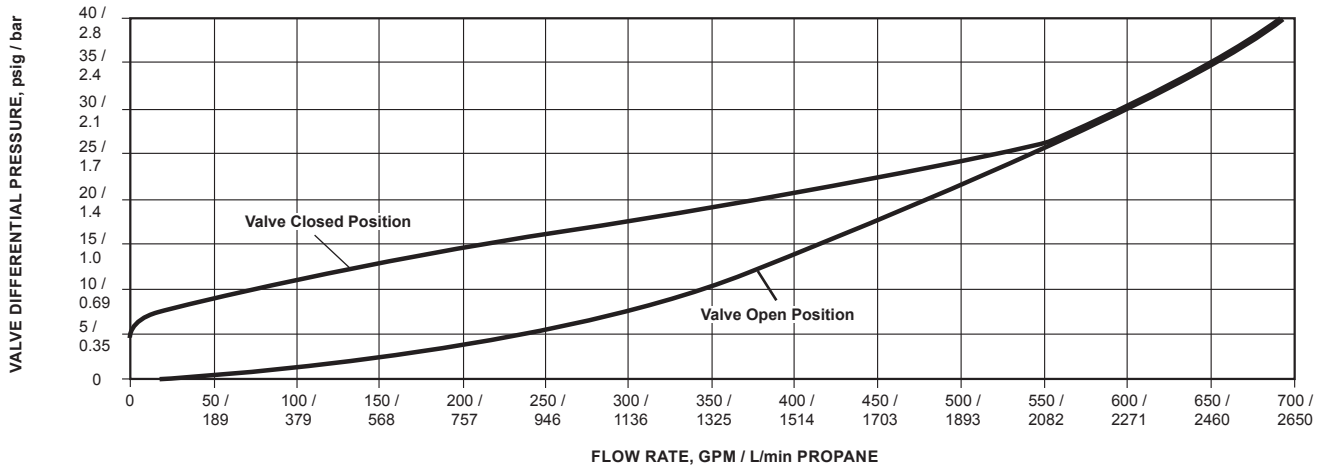

Figure 7. Type C477-24 Typical Reverse Flow Curve

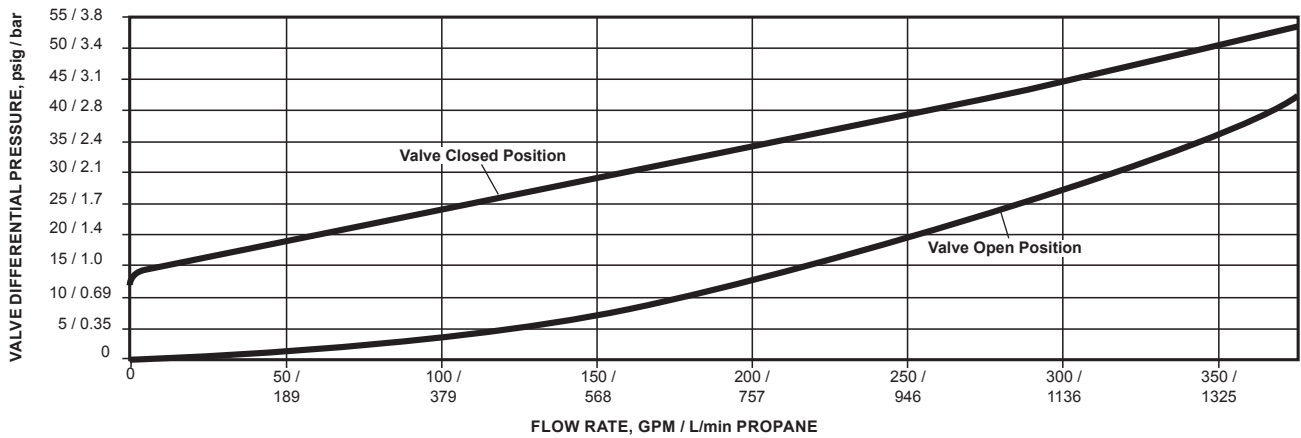

Figure 8. Type C477-16 Typical Reverse Flow Curve

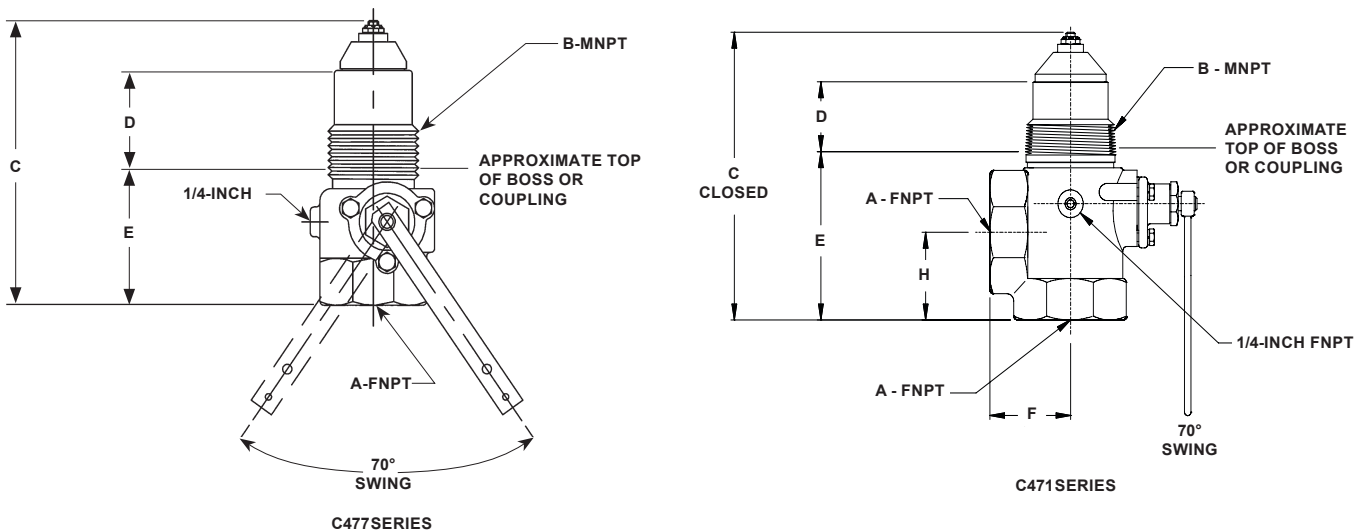

Figure 9. Dimensions

Table 3. Dimensions

| TYPE NUMBER | A, INCH FNPT / DN | B, INCH MNPT / DN | DIMENSIONS, INCHES / mm |           |            |           |           | INSTALLATION CLEARANCE DIAMETER |
|-------------|-------------------|-------------------|-------------------------|-----------|------------|-----------|-----------|---------------------------------|
|             |                   |                   | C                       | D         | E          | F         | H         |                                 |
| C471-16     | 2 / 50            | 2 / 50            | 8.07 / 205              | 2.40 / 61 | 4.05 / 103 | 2.76 / 70 | 2.66 / 68 | 10.00 / 254                     |
| C471-24     | 3 / 80            | 3 / 80            | 9.00 / 229              | 2.60 / 66 | 4.57 / 116 | 3.25 / 83 | 3.26 / 83 | 13.38 / 340                     |
| C477-16     | 2 / 50            | 2 / 50            | 8.07 / 205              | 2.40 / 61 | 4.05 / 103 | ----      | ----      | 10.00 / 254                     |
| C477-24     | 3 / 80            | 3 / 80            | 9.00 / 229              | 2.60 / 66 | 4.57 / 116 | ----      | ----      | 13.38 / 340                     |

# Bulletin LP-7:C471/C477

## Ordering Information

To order, refer to the table below and specify the type number that satisfies your requirement. Then, contact or visit your local LP-Gas Equipment Distributor for availability.

| SIZE           | TYPE NUMBER   |            | FLANGE CONNECTION SIZE, INCHES |   | ACTUATION METHOD AND DEVICE |                           |
|----------------|---------------|------------|--------------------------------|---|-----------------------------|---------------------------|
|                | Straight Body | Tee Body   | Inlet                          | Outlet  | Air                         | Manual with Thermal Latch |
| 2-inch / DN 50 | C477-16-10    | C471-16-10 | 2-inch MNPT / DN 50            | 2-inch FNPT / DN 50 (Straight)<br>2 x 2-inch FNPT / DN 50 x 50 (Tee Body) | Type P639                   | Type P340                 |
|                | C477-16-15    | C471-16-15 |                                |   |                             |                           |
|                | C477-16-25    | C471-16-25 |                                |   |                             |                           |
| 3-inch / DN 80 | C477-24-16    | C471-24-16 | 3-inch MNPT / DN 80            | 3-inch FNPT / DN 80 (Straight)<br>2 x 3-inch FNPT / DN 50 x 80 (Tee Body) | Type P639                   | Type P340                 |
|                | C477-24-26    | C471-24-26 |                                |   |                             |                           |
|                | C477-24-37    | C471-24-37 |                                |   |                             |                           |
|                | C477-24-46    | C471-24-46 |                                |   |                             |                           |

Please Contact Your Local LP-Gas Equipment Distributor for Availability of Non-Standard Options.

### LP-Gas Equipment

#### Emerson Process Management Regulator Technologies, Inc.

USA - Headquarters  
McKinney, Texas 75069-1872 USA  
Telephone: 1 (800) 558-5853  
Telephone: 1 (972) 548-3574

For further information visit [www.fisherregulators.com](http://www.fisherregulators.com)

The Emerson logo is a trademark and service mark of Emerson Electric Co. All other marks are the property of their prospective owners. Fisher is a mark owned by Fisher Controls, International LLC., a business of Emerson Process Management.

*The contents of this publication are presented for informational purposes only, and while every effort has been made to ensure their accuracy, they are not to be construed as warranties or guarantees, express or implied, regarding the products or services described herein or their use or applicability. We reserve the right to modify or improve the designs or specifications of such products at any time without notice.*

Emerson Process Management Regulator Technologies Inc., does not assume responsibility for the selection, use or maintenance of any product. Responsibility for proper selection, use and maintenance of any Emerson Process Management Regulator Technologies, Inc. product remains solely with the purchaser.