



KTM SERIES EF1 FLOATING BALL VALVES

TWO-PIECE, SPLIT BODY, FLANGED, FULL BORE

High performance ball valves for process applications, available in standard, firesafe and fugitive emission compliant configurations



FEATURES

- Two piece split body valve design with flanged connections
- Full compliance to ASME B16.34 and EN 12516-1
- Firesafe design tested and certified to API 607 7th Edition and ISO 10497:2010
- Firesafe E design features a double stainless steel body seal including PTFE primary seal and secondary graphite firesafe seal
- Fugitive emission compliant design features a double stem seal that complies with ISO 15848-1 Class BH C03 requirements (2500 cycles including thermal cycles)
- Carbon steel or stainless steel body materials
- Purchase procedure for carbon steel bodies specifies double material certification WCB/WCC and 1.0619/1.0625
- Investment cast body DN 15 - 100 (NPS ½ - 4)
- Sand cast body DN 125 - 300 (NPS 5 - 12)
- Optional casting per AD 2000 W0
- Standard ball valve with respect to the PAS1085 specification Class D
- ISO 5211 / EN 15081 top mounting plate available with male centering for easy actuation
- Double shaft seal design complies with TA Luft VDI 2440 requirements
- Patented SEALMASTER® stem seal arrangement
- Blow-out proof stem
- Anti-static design according to ISO 17292
- Various seat material options to suit a wide range of applications
- Tightness to API 598, EN 12266-1 Rate A
- Locking device standard on all valves
- Patented POSILOCK® handle for DN 15 - 50 (NPS ½ - 2) full bore

GENERAL APPLICATION

For industrial and process applications. The KTM Series EF1 has been designed according to the most stringent international standards and end-user specifications to be used in critical and hazardous applications in the chemical, petrochemical, oil and gas and related industries. These valves are available in standard, firesafe and fugitive emission certified designs.

TECHNICAL DATA

Sizes:	DN 15 - 300 NPS ½ - 12 Full bore
Pressure rating:	PN 10/16 PN 25/40 ASME Class 150/300
End connection Flanged:	PN 10/16, PN 25/40 ASME Class 150/300

KTM SERIES EF1 FLOATING BALL VALVES

STANDARD CONFIGURATION

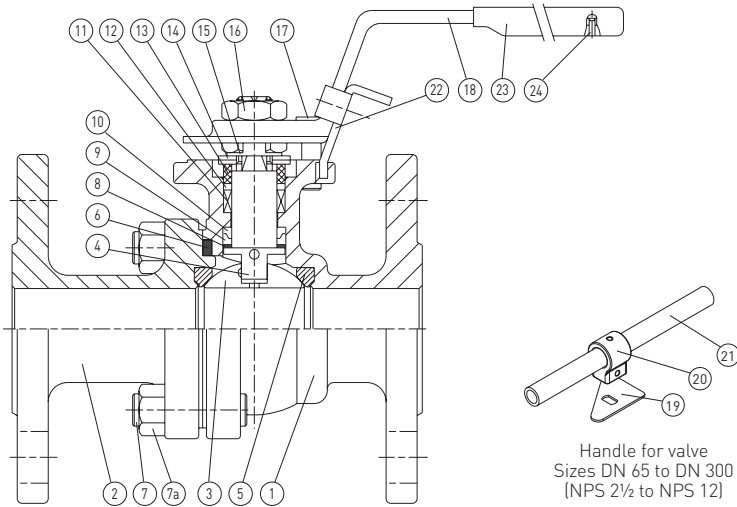

MATERIALS OF CONSTRUCTION

No.	Parts name	Material	Quantity
1*	Body	EN 1.4408/1.0619	1
2*	Cap	EN 1.4408/1.0619	1
3	Ball	EN 1.4408	1
4	Anti-static stem	A276 Type 316 ^[1]	1
5	Ball seat	PTFE or TFM 1600	2
6	Body seal	PTFE	1
7	Stud	A193 Gr. B8 / A193 Gr. B7	4-26
7a	Nut	A194 Gr. 8 / A194 Gr. 2H	4-26
8	Lower thrust washer	50% SS powder / 50% PTFE	1
9	Compress ring	316L SS DN 15 - 100 (NPS 1/2 - 4) / 316 SS DN 125 - 300 (NPS 5 - 12)	1
10	Upper thrust washer	TFM 1600	1
11	V-ring shaft packing	PTFE	1 set
12	Thrust washer	50% SS powder / 50% PTFE	1
13	Gland	304 SS	1
14	Belleville washer	301 SS	2
15	Lock saddle	Stainless steel	1
16	Stem nut	304 SS	1-2
17	Stop bolt	Stainless steel	1-2
18	Handle (DN 15 - 50)	CF8	1
19	Triangle stopper (DN 65 - 300)	Stainless steel	1
20	Handle adapter (DN 65 - 300)	CF8 DN 65 - 125 (NPS 2 1/2 - 5) / A536 DN 150 - 300 (NPS 6 - 12)	1
21	Handle (DN 65 - 300)	SGP Zn plating	1
22	Locking trigger	Stainless steel	1
23	Handle sleeve	Vinyl	1
24	Rivet	304 SS	1

MAXIMUM ALLOWABLE STEM TORQUE (Nm)

Size DN	Body material	Class 150 PN 10/16	Class 300 PN 25/40
15/20	SS/CS	25	25
25/32	SS/CS	40	40
40/50	SS/CS	78	78
65/80	SS/CS	318	318
100/125	SS/CS	392	392
150	SS	637	1382
	CS	637	2252
200	SS	1382	1382
	CS	2252	2252
250	SS	2850	2850
	CS	4644	4644
300	SS	2850	2850
	CS	4644	4644

SS = Stainless Steel, CS = Carbon Steel

NOTES

1. Standard shaft material

* For Class valves, the body and cap material will be ASTM A351 Gr. CF8M / ASTM A216 Gr. WCB

STANDARD STEM MATERIAL

Body material	Size	Class 150, PN 10/16	Class 300, PN 25/40
CF8M,	DN 15 - 125 (NPS 1/2 - 5)	316	316
SCS14A,	DN 150 (NPS 6)	316	2205 (A276-S31803)
1.4408	DN 200 - 300 (NPS 8 - 12)	2205 (A276-S31803)	2205 (A276-S31803)
WCB,	DN 15 - 125 (NPS 1/2 - 5)	316	316
SCPH2,	DN 150 (NPS 6)	316	17-4 (A564-630)
1.0619	DN 200 - 300 (NPS 8 - 12)	17-4 (A564-630)	17-4 (A564-630)

KTM SERIES EF1 FLOATING BALL VALVES

FIRESAFE CONFIGURATION

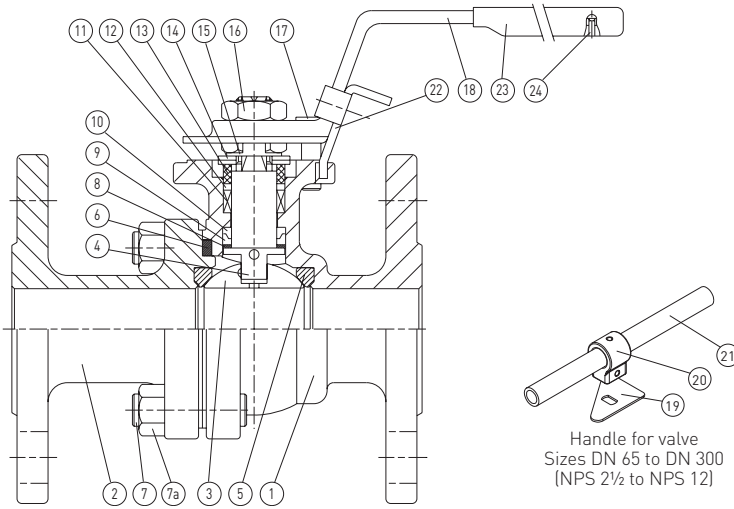

MATERIALS OF CONSTRUCTION

No.	Parts name	Material	Quantity
1*	Body	EN 1.4408/1.0619	1
2*	Cap	EN 1.4408/1.0619	1
3	Ball	EN 1.4408	1
4	Anti-static stem	A276 type 316 ^[1]	1
5	Ball seat	PTFE or TFM 1600	2
6	Body seal	Graphite DN 15 - 100 (NPS ½ - 4) / 316 SS spiral wound graphite DN 125 - 300 (NPS 5 - 12)	1
7	Stud	A193 Gr. B8 / A193 Gr. B7	4-26
7a	Nut	A194 Gr. 8 / A194 Gr. 2H	4-26
8	Lower thrust washer	50% SS powder / 50% PTFE	1
9	Compress ring	316L SS DN 15 - 100 (NPS ½ - 4) / 316 SS DN 125 - 300 (NPS 5 - 12)	1
10	Upper thrust washer	Graphite	1
11	Stem packing	Graphite	1 set
12	Thrust washer	50% SS powder / 50% PTFE	1
13	Gland	304 SS	1
14	Belleville washer	301 SS	2
15	Lock saddle	Stainless steel	1
16	Stem nut	304 SS	1-2
17	Stop bolt	Stainless steel	1-2
18	Handle DN 15 - 50 (NPS ½ - 2)	CF8	1
19	Triangle stopper DN 65 - 300 (NPS 2½ - 12)	Stainless steel	1
20	Handle adapter DN 65 - 300 (NPS 2½ - 12)	CF8 DN 65 - 125 (NPS 2½ - 5) / A536 DN 150 - 300 (NPS 6 - 12)	1
21	Handle DN 65 - 300 (NPS 2½ - 12)	SGP Zn plating	1
22	Locking trigger	Stainless steel	1
23	Handle sleeve	Vinyl	1
24	Rivet	304 SS	1

MAXIMUM ALLOWABLE STEM TORQUE (Nm)

Size DN	Body material	Class 150 PN 10/16	Class 300 PN 25/40
15/20	SS/CS	25	25
25/32	SS/CS	40	40
40/50	SS/CS	78	78
65/80	SS/CS	318	318
100/125	SS/CS	392	392
150	SS	637	1382
	CS	637	2252
200	SS	1382	1382
	CS	2252	2252
250	SS	2850	2850
	CS	4644	4644
300	SS	2850	2850
	CS	4644	4644

SS = Stainless Steel, CS = Carbon Steel

FEATURES

- Secondary metal to metal seating surface
- Flexible graphite body and shaft packing for high temperature resistance
- Fire tested to API 607 7th Edition up to DN 200 (NPS 8)

NOTES

1. Standard shaft material * For Class valves, the body and cap material will be ASTM A351 Gr. CF8M / ASTM A216 Gr. WCB

STANDARD STEM MATERIAL

Body material	Size	Class 150, PN 10/16	Class 300, PN 25/40
CF8M,	DN 15 - 125 (NPS ½ - 5)	316	316
SCS14A,	DN 150 (NPS 6)	316	2205 (A276-S31803)
1.4408	DN 200 - 300 (NPS 8 - 12)	2205 (A276-S31803)	2205 (A276-S31803)
WCB,	DN 15 - 125 (NPS ½ - 5)	316	316
SCPH2,	DN 150 (NPS 6)	316	17-4 (A564-630)
1.0619	DN 200 - 300 (NPS 8 - 12)	17-4 (A564-630)	17-4 (A564-630)

KTM SERIES EF1 FLOATING BALL VALVES

FUGITIVE EMISSION CERTIFIED AND FIRESAFE CONFIGURATION

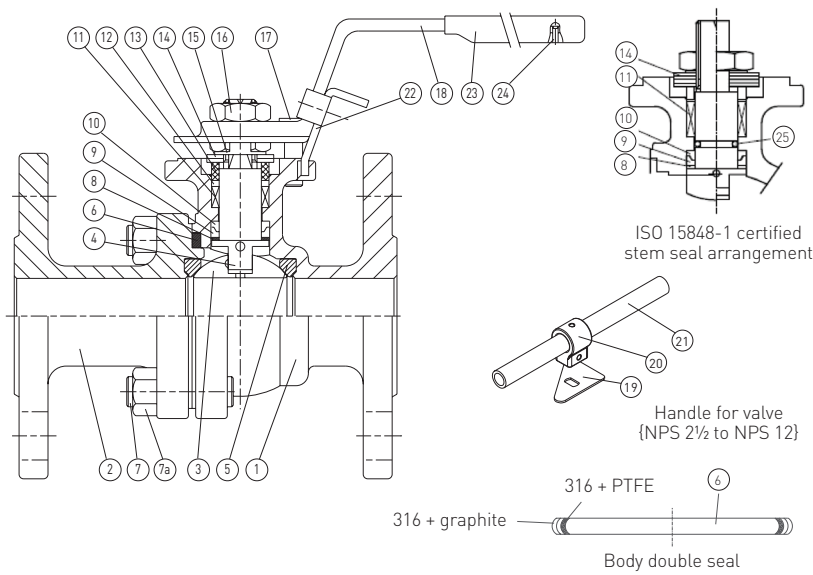

MATERIALS OF CONSTRUCTION

No.	Part name	Material	Quantity
1*	Body	EN 1.4408 / 1.0619	1
2*	Cap	EN 1.4408 / 1.0619	1
3	Ball	EN 1.4408	1
4	Anti-static stem	A276 type 316 ⁽¹⁾	1
5	Ball seat	PTFE or TFM 1600	2
6	Body seal	Inner seal: PTFE Outer seal: 316L SS spiral wound with graphite	1
7	Stud	A193 Gr.B8 / A193 Gr.B7	4-26
7a	Nut	A194 Gr.8 / A194 Gr.2H	4-26
8	Lower thrust washer	50% S/S Powder / 50% PTFE	1
9	Compress ring	316L S/S	1
10	Upper thrust washer	TFM 1600	1
11	Stem packing	Graphite	1 set
12	Thrust washer	50% S/S Powder / 50% PTFE	1
13	Gland	304 S/S	1
14	Belleville washer	301 S/S	4
15	Lock saddle	Stainless Steel	1
16	Stem nut	304 S/S	1-2
17	Stop bolt	Stainless Steel	1-2
18	Handle DN 15 - 50 (NPS ½ - 2)	CF8	1
19	Triangle stopper DN 65 - 300 (NPS 2½ - 12)	Stainless Steel	1
20	Handle adapter DN 65 - 300 (NPS 2½ - 12)	CF8 DN 65 - 125 (NPS 2½ - 5) A536 DN 150 - 300 (NPS 6 - 12)	1
21	Handle DN 65 - 300 (NPS 2½ - 12)	SGP Zn plating	1
22	Locking trigger	Stainless Steel	1
23	Handle sleeve	Vinyl	1
24	Rivet	304 S/S	1
25	O-ring	FKM	1

NOTES

- Standard stem material
- * For Class valves, the body and cap material will be ASTM A351 Gr. CF8M / ASTM A216 Gr. WCB

STANDARD STEM MATERIAL

Body material	Size	Class 150, PN 10/16	Class 300, PN 25/40
CF8M,	DN 15 - DN 125 (NPS ½ - NPS 5)	316	316
SCS14A,	DN 150 (NPS 6)	316	2205 (A276-S31803)
1.4408	DN 200 - DN 300 (NPS 8 - NPS 12)	2205 (A276-S31803)	2205 (A276-S31803)
WCB,	DN 15 - DN 125 (NPS ½ - NPS 5)	316	316
SCPH2,	DN 150 (NPS 6)	316	17-4 (A564-630)
1.0619	DN 200 - DN 300 (NPS 8 - NPS 12)	17-4 (A564-630)	17-4 (A564-630)

MAXIMUM ALLOWABLE STEM TORQUE (Nm)

Size DN	Body material	Class 150 PN 10/16	Class 300 PN 25/40
15/20	SS/CS	25	25
25/32	SS/CS	40	40
40/50	SS/CS	78	78
65/80	SS/CS	318	318
100/125	SS/CS	392	392
150	SS	637	1382
200	CS	637	2252
250	SS	2850	2850
300	CS	4644	4644
300	CS	4644	4644

SS = Stainless Steel, CS = Carbon Steel

FEATURES

- Secondary metal to metal seating surface
- Flexible graphite body and stem packing for high temperature resistance
- Fire tested to API 607 7th Edition to DN 200 (NPS 8)
- Fugitive emission tested to ISO 15848-1, Class BH, C03 requirements (2500 cycles including thermal cycles to 200°C)
- Double stainless steel body seal with PTFE coating at the inner diameter, stainless steel rings and graphite ring

KTM SERIES EF1 FLOATING BALL VALVES

DIMENSIONS

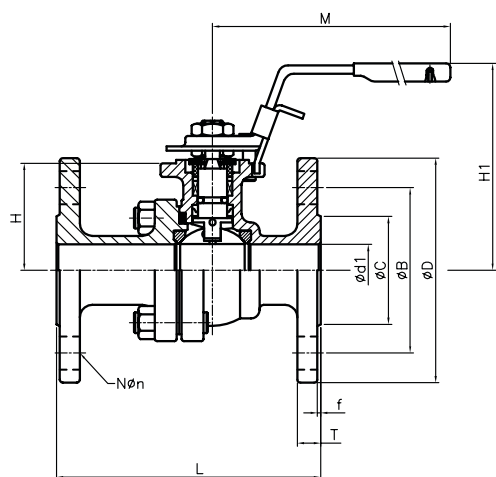

Sizes DN 15 - 50
(NPS 1/2 - 2)

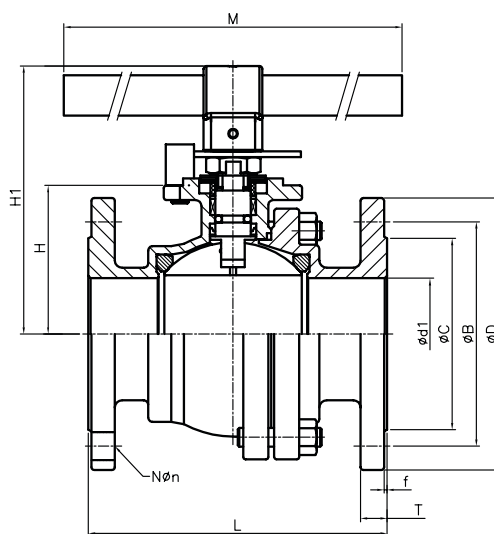

Sizes DN 65 - 300
(NPS 2 1/2 - 12)

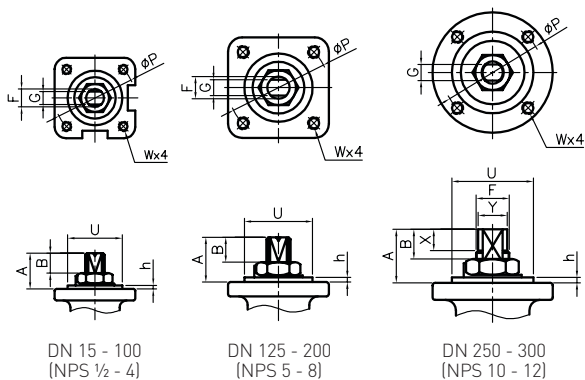

DN 15 - 100
(NPS 1/2 - 4)

DN 125 - 200
(NPS 5 - 8)

DN 250 - 300
(NPS 10 - 12)

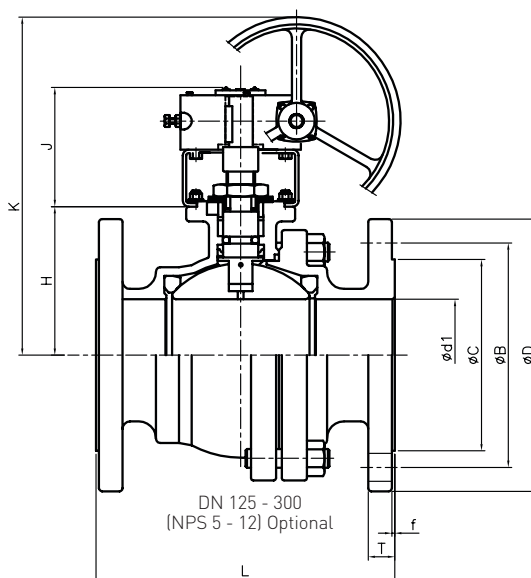

DN 125 - 300
(NPS 5 - 12) Optional

DIMENSIONS (mm)

DN	NPS	A	Ø P	F	G	B	U	h	W	M	H	H1	J	K	X	Y
15	1/2	20.3	42	9.7	6.3	12.0	30	2	M5	135	38.5	82	-	-	-	-
20	3/4	20.5	42	9.7	6.3	12.4	30	2	M5	135	42.0	86	-	-	-	-
25	1	21.6	50	11.2	8.0	14.0	35	3	M6	165	51.5	98	-	-	-	-
32	1 1/4	21.6	50	11.2	8.0	14.0	35	3	M6	165	56.7	102	-	-	-	-
40	1 1/2	26.0	70	16.0	9.5	16.2	55	3	M8	200	65.5	119	-	-	-	-
50	2	26.0	70	16.0	9.5	16.2	55	3	M8	200	74.5	128	-	-	-	-
65	2 1/2	43.0	102	22.3	17.0	24.7	70	3	M10	495	88.0	162	-	-	-	-
80	3	43.5	102	22.3	17.0	25.2	70	3	M10	495	101.0	172	-	-	-	-
100	4	49.0	102	28.6	17.0	30.0	70	3	M10	595	122.0	197	-	-	-	-
125	5	53.6	102	28.6	17.0	33.0	70	3	M10	650	140.0	226	161	393	-	-
150	6	65.0	125	34.0	23.0	39.0	85	3	M12	800	167.0	281	190	513	-	-
200	8	65.0	125	34.0	23.0	39.0	85	3	M12	1100	203.0	317	190	549	-	-
250	10	83.5	140	50.0	30.0	52.0	100	3	M16	1100	263.0	378	221	625	40	47
300	12	83.5	140	50.0	30.0	52.0	100	3	M16	1100	305.0	420	221	667	40	47

KTM SERIES EF1 FLOATING BALL VALVES

DIMENSIONS

ASME 150/300 DIMENSIONS (mm)

DN	NPS	Ø B		Ø D		L		N		T		Ø n		Ø C	Ø d1	f	Wt (kg)	
		150	300	150	300	150	300	150	300	150	300	150	300				150	300
15	½	60.5	66.5	89.0	95.0	108.0	140.0	4	4	11.2	14.3	16.0	16.0	35	15	1.6	1.82	2.20
20	¾	70.0	82.5	98.6	117.0	117.0	152.0	4	4	11.2	15.9	16.0	19.0	43	20	1.6	2.12	3.25
25	1	79.5	89.0	108.0	124.0	127.0	165.0	4	4	11.2	17.5	16.0	19.0	51	25	1.6	3.04	4.48
40	1½	98.5	114.5	127.0	156.0	165.0	190.0	4	4	14.2	20.7	16.0	22.0	73	40	1.6	5.80	8.70
50	2	120.5	127.0	152.5	165.0	178.0	216.0	4	8	15.9	22.3	19.0	19.0	92	50	1.6	8.36	11.20
65	2½	139.5	149.0	178.0	190.0	190.0	241.0	4	8	17.5	25.4	19.0	22.0	105	65	1.6	15.00	19.00
80	3	152.5	168.0	190.5	210.0	203.0	283.0	4	8	19.1	28.6	19.0	22.0	127	76	1.6	19.92	28.00
100	4	190.5	200.0	229.0	254.0	229.0	305.0	8	8	23.9	31.8	19.0	22.0	157	100	1.6	32.90	43.72
125	5	215.9	234.9	254.0	279.4	355.6	381.0	8	8	23.8	34.9	22.2	22.2	186	125	1.6	49.00	71.00
150	6	241.3	269.9	279.4	317.5	393.7	403.4	8	12	25.4	36.6	22.2	22.2	216	150	1.6	75.00	100.00
200	8	298.4	330.2	342.9	381.0	457.2	501.7	8	12	28.6	41.3	22.2	25.4	270	200	1.6	128.00	172.00
250	10	361.9	387.3	406.4	444.5	533.4	568.5	12	16	30.2	47.6	25.4	28.6	324	250	1.6	215.00	291.00
300	12	431.8	450.8	482.6	520.7	609.6	647.7	12	16	31.8	50.8	25.4	31.8	381	300	1.6	254.00	423.00

DIN PN 10/16/25/40 DIMENSIONS (mm)

DN	NPS	PN	Ø B	Ø C	Ø D	L	L*	N	T	Ø n	Ø d1	f	Wt (kg)	
													F1	F4/F5
15	½	10/16/25/40	65	45	95	115	130	4	16	14	15	2	2.42	2.46
20	¾	10/16/25/40	75	58	105	120	150	4	18	14	20	2	3.24	3.08
25	1	10/16/25/40	85	68	115	125	160	4	18	14	25	2	4.42	4.18
32	1¼	10/16/25/40	100	78	140	130	180	4	18	18	32	2	6.10	5.62
40	1½	10/16/25/40	110	88	150	140	200	4	18	18	40	3	7.94	7.40
50	2	10/16/25/40	125	102	165	150	230	4	20	18	50	3	10.50	9.76
65	2½**	10/16	145	122	185	170	290	4	18	18	65	3	17.00	16.60
		25/40	145	122	185	170	290	8	22	18	65	3	18.30	16.22
80	3	10/16	160	138	200	180	310	8	20	18	80	3	21.50	21.40
		25/40	160	138	200	180	310	8	24	18	80	3	24.90	21.34
100	4	10/16	180	158	220	190	350	8	20	18	100	3	34.00	27.72
		25/40	190	162	235	190	350	8	24	22	100	3	37.20	31.42
125	5	10/16	210	188	250	325	400	8	22	18	125	3	50.00	48.00
		25/40	220	188	270	325	400	8	26	26	125	3	60.00	57.00
150	6	10/16	240	212	285	350	480	8	22	22	150	3	78.00	73.00
		25/40	250	218	300	350	480	8	28	26	150	3	92.00	82.00
200	8	10	295	268	340	400	600	8	24	22	200	3	124.00	98.00
		16	295	268	340	400	600	12	24	22	200	3	124.00	98.00
		25	310	278	360	400	600	12	30	26	200	3	164.00	148.00
		40	320	285	375	400	600	12	34	30	200	3	164.00	148.00
250	10	10	350	320	395	450	730	12	26	22	250	3	270.00	203.00
		16	355	320	405	450	730	12	26	26	250	3	270.20	203.00
300	12	10	400	370	445	500	850	12	26	22	300	4	N/A	233.00
		16	410	378	460	500	850	12	28	26	300	4	N/A	233.00

L dimensions DN 15 - 100 - ISO 5752 series 14 (F4); DN 125 - 300 - ISO 5752 series 15 (F5) or DN 15 - 300 - EN 558 series 27

* L dimensions DN 15 - 300 - ISO 5752 series 1 or EN 558 series 1

** For DN 65, PN 25/40 F1, please contact your sales representative

KTM SERIES EF1 FLOATING BALL VALVES

ACTUATION

POSILOCK® handle

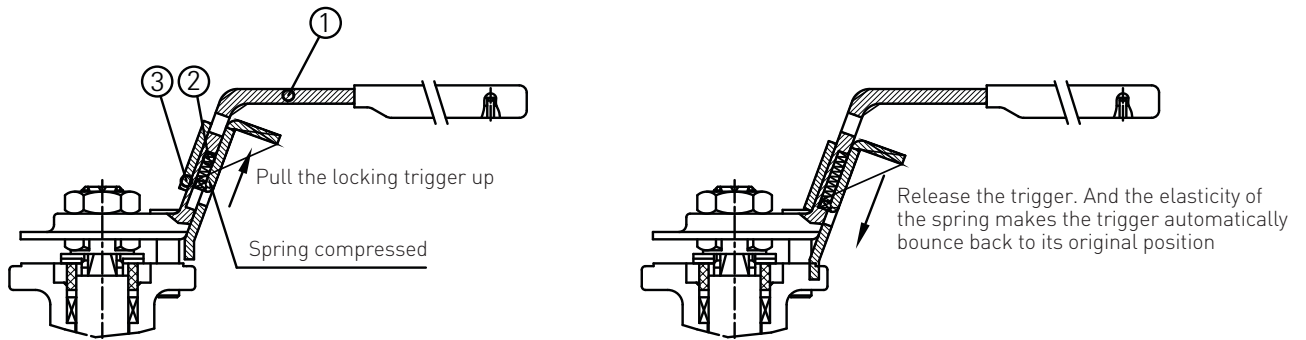

FEATURES

- Simple construction
- Smooth action for locking trigger
- Wrapped locking trigger design prevents the spring from coming out
- The elasticity of the spring makes the trigger automatically bounce back to its original position, which keeps the plate in position for firm locking. This also avoids unwanted valve operation caused by accident.

PARTS LIST

No.	Parts name
1	Handle
2	Spring
3	Locking trigger

TOP WORKS DIMENSIONS (mm) - SPIGOT

Flange type	Ø P	W
F03	36	M5
F04	42	M5
F05	50	M6
F07	70	M8
F10	102	M10
F12	125	M12
F14	140	M16

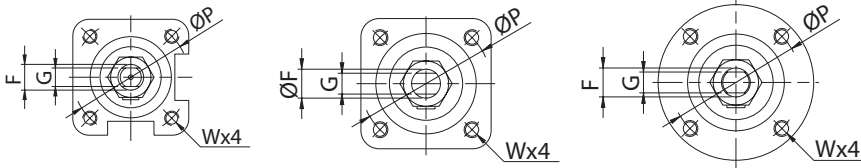

SERIES EF1 BREAK-AWAY TORQUE (Nm) - PTFE OR TFM 1600 SEAT

Size DN	NPS	Differential pressure: bar (psi)					
		0	6.9 (100)	13.8 (200)	20.7 (300)	27.6 (400)	34.5 (500)
15	1/2	8.4	8.6	8.7	8.9	9.1	9.5
20	3/4	11.5	12.5	12.5	13.0	13.0	13.5
25	1	13.5	13.5	14.0	14.5	15.0	16.0
32	1 1/4	14.0	14.2	14.4	15.3	16.8	18.1
40	1 1/2	23.5	24.0	24.5	25.0	25.5	26.0
50	2	30.5	31.0	31.5	31.5	32.0	32.5
65	2 1/2	42.5	46.0	50.0	52.0	58.0	65.0
80	3	58.0	82.0	100.0	125.0	145.0	155.0
100	4	82.0	88.0	110.0	145.0	175.0	210.0
125	5	125.0	130.0	150.0	190.0	240.0	300.0
150	6	175.0	240.0	305.0	490.0	650.0	750.0
200	8	180.0	300.0	420.0	690.0	870.0	-
250	10	350.0	760.0	1250.0	1700.0	2050.0	-
300	12	470.0	870.0	1500.0	2350.0	-	-

NOTES

1. Increase by 25% for MG1241, carbon and SS filled seat.
2. Increase by 15% for dry gas or oil free products.
3. Increase by 40% for dry gas (-10 °C and below).
4. Increase by 40% for gas below -10 °C or for liquid with slurry powder.
5. Increase by 40% for high viscosity fluid.
6. For actuator sizing, we recommend to add at least 20% of the break-away torque of valve as safety factor.

KTM SERIES EF1 BALL VALVES

SEALMASTER® STEM SEAL ARRANGEMENT

PATENTED SEALMASTER STEM SEAL ARRANGEMENT

The high performance of KTM Series EF1 Ball Valves is mainly due to unique SEALMASTER stem seal arrangement, which provides a primary sealing. It has been specially designed and constructed to prevent line fluid permeation and resultant leakage. On top of this arrangement are multiple layers of V-Ring stem packing that acts as secondary sealing. A set of Belleville washers automatically and constantly compresses the seals to adjust for wear, pressure and temperature fluctuations.

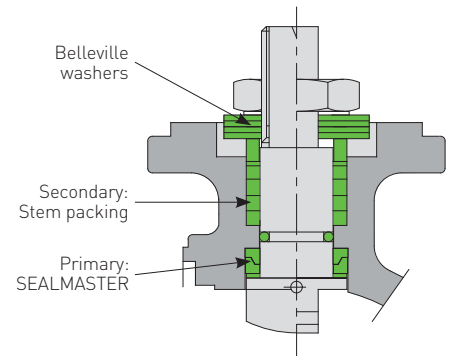

HOW SEALMASTER WORKS

The live loaded SEALMASTER is a combination of 3 components; (A) a cup and cone PFA/TFE upper thrust seal, (B) a cup and cone sintered 316 SS center load ring and (C) a flat SS/TFE lower thrust seal. When tightened, the live loaded stem pulls up and compressing the stem thrust seals. As this happens, material from the upper and lower thrust seal extrude between stem and body enclosures. (See 1-6). The surfaces between the bottom of the lower thrust seal and top of the stem flange are smooth and all rotation occurs between these two surfaces leaving the stem thrust seal 'static' to create the best possible seal. As rotation continues, components bed in and keep seal performance constant with usage.

The unique design of the SEALMASTER stem seal arrangement delivers:

- MULTIPLE sealing up to 6 areas (see view 1 - 6).
- Encapsulated STATIC sealing achieved on upper thrust seal.
- Constant sealing force transmitted to stem (see arrow) making stem primary sealing 'positive'.
- Excellent wear resistance on lower thrust seal (50% SS filled PTFE).
- Reduced seal friction as a result of better than Ra 0.8 m (150 grit) stem finish.

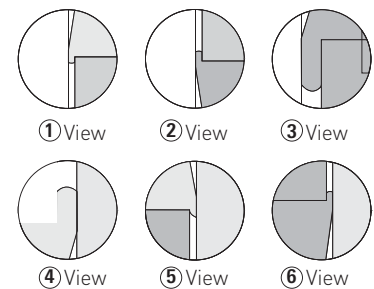
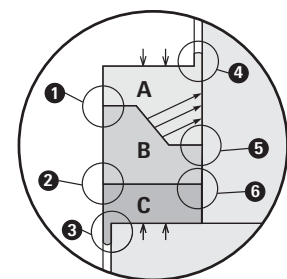

STEM SEAL ARRANGEMENT

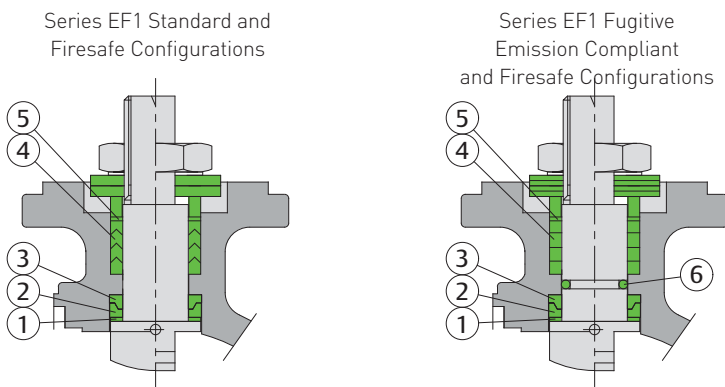

No.	Part name	Series EF1 - Standard	Series EF1 - Firesafe	Series EF1 - FE Compliant
1	Lower thrust washer	50% SS powder / 50% PTFE	50% SS powder / 50% PTFE	50% SS powder / 50% PTFE
2	Compress ring	316 SS	316 SS	316 SS
3	Upper thrust washer	TFM 1600	Graphite	TFM 1600
4	Stem packing	PTFE	Graphite	Graphite
5	Thrust washer	50% SS powder / 50% PTFE	50% SS powder / 50% PTFE	50% SS powder / 50% PTFE
6	O-ring	-	-	FKM

KTM SERIES EF1 FLOATING BALL VALVES

PRESSURE AND TEMPERATURE RATINGS

Series EF1 - ASME
Split-body flanged ball valve
DN 15 - 20 (NPS ½ - ¾) - full bore

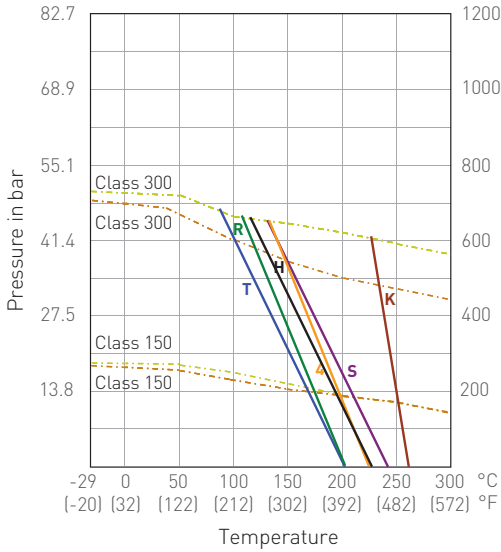

Series EF1 - ASME
Split-body flanged ball valve
DN 25 - 65 (NPS 1 - 2½) - full bore

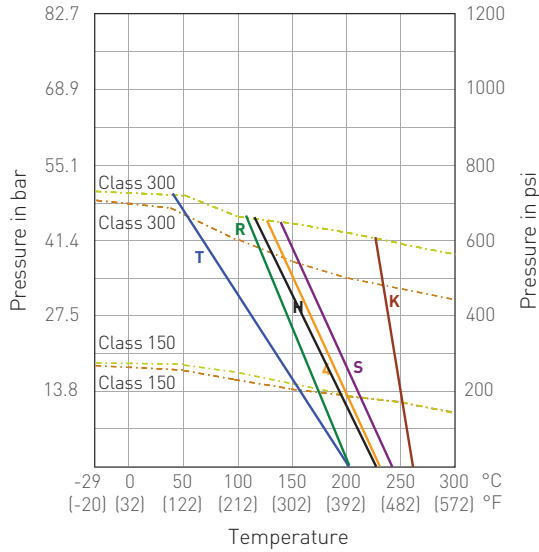

Series EF1 - ASME
Split-body flanged ball valve
DN 80 - 100 (NPS 3 - 4) - full bore

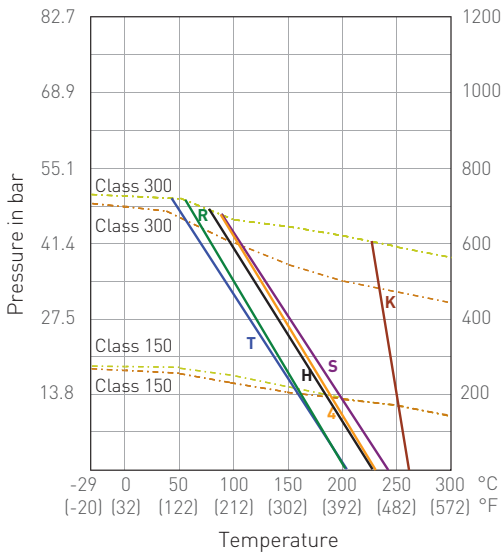

Series EF1 - ASME
Split-body flanged ball valve
DN 125 - 300 (NPS 5 - 12) - full bore

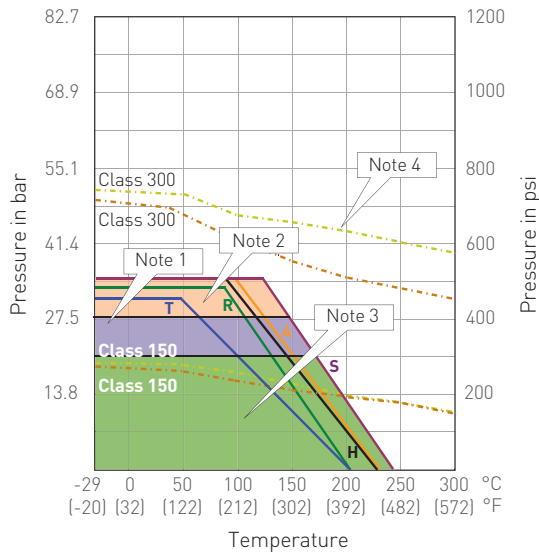

- = 1.0619 body rating
- = 1.4408 body rating
- = WCB body rating
- = CF8M body rating
- T = PTFE
- R = RPTFE
- A = 25% carbon filled PTFE
- S = 50% SS filled PTFE
- K = PEEK (ARLON 1330)
- H = TFM 1600

NOTES

1. NPS 8 and 10 maximum operating pressure 27.6 bar (400 psig). Please consult factory for this range of application.
2. NPS 5 and 6 maximum operating pressure 34.5 bar (500 psig).
3. NPS 12 maximum operating pressure 20.7 bar (300 psig).
4. 50% SS filled PTFE and 25% carbon filled PTFE shall not exceed this rating line for ASME Class 300.
5. Temperature rating for stainless steel bodies is extended from ambient temperature to -60°C (-76°F).

KTM SERIES EF1 FLOATING BALL VALVES

PRESSURE AND TEMPERATURE RATINGS

Series EF1 - DIN
Split-body flanged ball valve
DN 15 - 20 (NPS ½ - ¾) - full bore

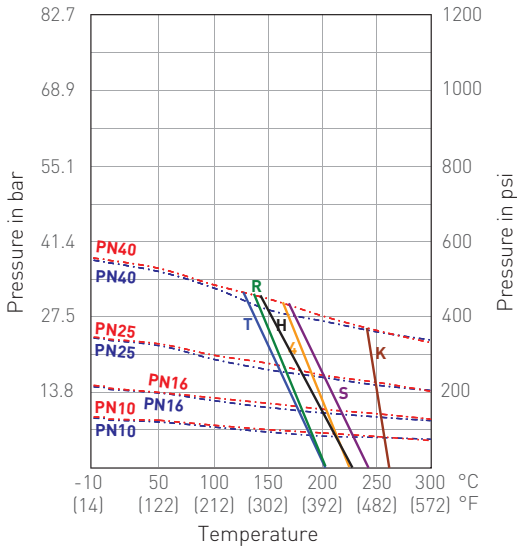

Series EF1 - DIN
Split-body flanged ball valve
DN 25 - 65 (NPS 1 - 2½) - full bore

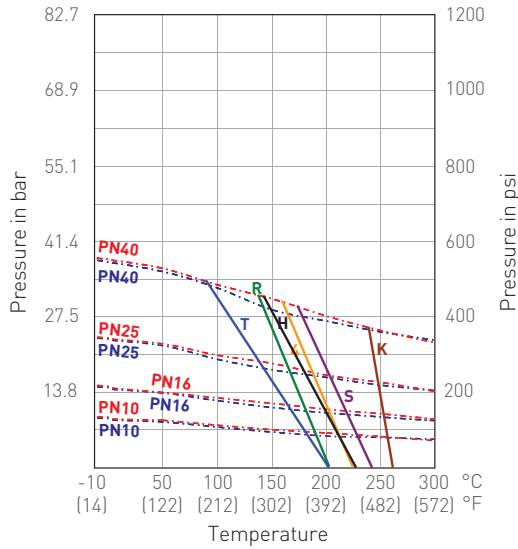

Series EF1 - DIN
Split-body flanged ball valve
DN 80 - 100 (NPS 3 - 4) - full bore

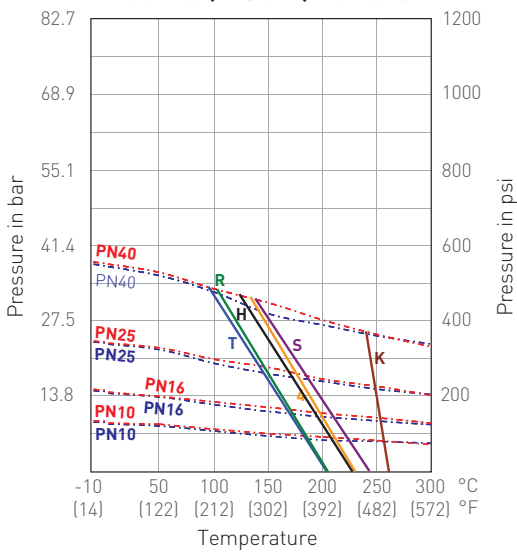

Series EF1 - DIN
Split-body flanged ball valve
DN 125 - 300 (NPS 5 - 12) - full bore

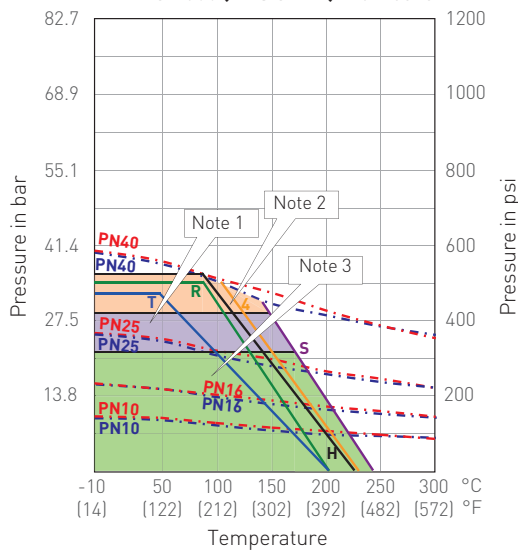

- . - . - . = 1.0619 body rating
- . - . - . = 1.4408 body rating
- . - . - . = WCB body rating
- . - . - . = CF8M body rating
- T = PTFE
- R = RPTFE
- 4 = 25% carbon filled PTFE
- S = 50% SS filled PTFE
- K = PEEK (ARLON 1330)
- H = TFM 1600

NOTES

1. DN 200 and 250 maximum operating pressure 27.6 bar (400 psig). Please consult factory for this range of application.
2. DN 125 and 150 maximum operating pressure 34.5 bar (500 psig).
3. DN 300 maximum operating pressure 20.7 bar (300 psig).
4. Temperature rating for stainless steel bodies is extended from ambient temperature to -60°C [-76°F].

VCTDS-04534-EN © 2016, 2021 Emerson Electric Co. All rights reserved 11/21. KTM is a mark owned by one of the companies in the Emerson Automation Solutions business unit of Emerson Electric Co. The Emerson logo is a trademark and service mark of Emerson Electric Co. All other marks are the property of their prospective owners.

The contents of this publication are presented for informational purposes only, and while every effort has been made to ensure their accuracy, they are not to be construed as warranties or guarantees, express or implied, regarding the products or services described herein or their use or applicability. All sales are governed by our terms and conditions, which are available upon request. We reserve the right to modify or improve the designs or specifications of such products at any time without notice.

Emerson Electric Co. does not assume responsibility for the selection, use or maintenance of any product. Responsibility for proper selection, use and maintenance of any Emerson Electric Co. product remains solely with the purchaser.