

### Features and Benefits

- High flow rate up to 650 l/min
- Spool & Sleeve or rubber packed technology in the same dimension body
- Wide electrical connection selection : G3 or 580 Fieldbus Electronics, 25 or 37 Pin Sub-D connector, 19 Pin Round connector, 26 Pin Round connector or Terminal Strip
- Internal or external pilot pressure supply capability
- Compliance with ISO standard 15407-2 18 mm
- Solenoid air operated valves which can be mounted on manifold bases
- 580 Electronics

### General

<b>Operating pressure</b>	See «SPECIFICATIONS» [1 bar =100 kPa]
<b>Ambient temperature range (TS)</b>	See «SPECIFICATIONS»
<b>Rated flow</b>	See «SPECIFICATIONS»
conforming to ISO 6358	C (5/2) = 24.24 x 10 <sup>-9</sup> m <sup>3</sup> /s.Pa (sonic conductance) b (5/2) = 0.28 (critical pressure ratio)
<b>Pneumatic base</b>	High flow subbase or ISO 15407-2 18 mm
<b>Connection</b>	Joinable subbase
<b>Response time</b>	See «SPECIFICATIONS»

fluids (*)	temperature range (TS)	technology	seal materials (*)
air or inert gas ISO 8573 Level 7.4.4	-10°C to +50°C	rubber packed	PUR (polyurethane)
	-10°C to +50°C	spool & sleeve	metal-to-metal sealing

### Materials in contact with fluid

(\*) Ensure that compatibility of materials in contact with fluids is verified.

<b>Body</b>	Aluminium, E-coating treatment
<b>Spool</b>	Aluminium or st. steel (spool & sleeve)
<b>Piston</b>	POM (rubber packed)
<b>Spring</b>	Stainless steel
<b>Other seals</b>	NBR
<b>Other materials</b>	PA (polyamide) GF 50% (glass fiber reinforced)
<b>Subbases</b>	Aluminium, E-coating treatment

### Electrical characteristics

<b>Coil insulation class</b>	F
<b>Electrical safety</b>	IEC-EN 60730-1 / IEC-EN 60730-2-8
<b>Electrical enclosure protection</b>	IP65 (EN 60529)
<b>Standard voltages</b>	DC (=): 24V
<b>Power ratings (hot/cold) (=)</b>	1.1 W / 1.3 W

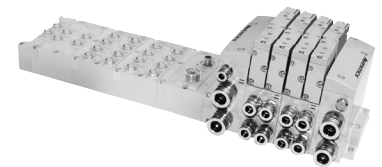
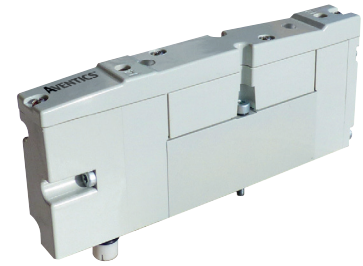

**Specifications**

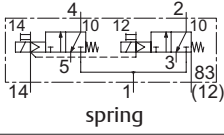
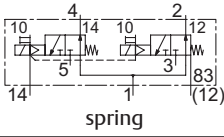
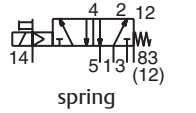
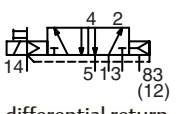
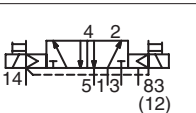
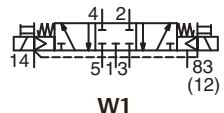
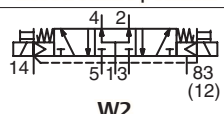
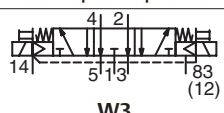

function	type	symbol	interface	rated flow		response time open / closed (ms)	pilot pressure at 23°C (bar)		operating pressure port 1		Catalog number 
				at 6.3 bar ΔP 1 bar l/min (ANR)			min.	max. (PS) air (*)	min.	max.	
				1 → 2 1 → 4	2 → 3 4 → 5						
<b>SPOOL VALVE, RUBBER PACKED TECHNOLOGY, WITH IMPULSE MANUAL OPERATOR</b>											
2 x 3/2 NC	K	 spring	High flow	650	600	39 / 19	(a)	8	2	8	R502A2BD0MA00F1
			ISO subbase	500	440						
2 x 3/2 NO	N	 spring	High flow	580	570	19 / 26	(b)	8	2	8	R502A2BA0MA00F1
			ISO subbase	500	470						
5/2	S	 spring	High flow	630	660	17 / 38	3	8	-0.95	8	R502A2B10MA00F1
			ISO subbase	510	510						
	M	 differential return	High flow	630	660	17 / 44	2	8	-0.95	8	R502A2BN0MA00F1
			ISO subbase	510	510						
J	 solenoid air	High flow	630	660	14 / 14	2	8	-0.95	8	R502A2B40MA00F1	
		ISO subbase	510	510							
5/3	G	 W1 closed centre position	High flow	560	610	18 / 18	3	8	-0.95	8	R502A2B60MA00F1
			ISO subbase	490	490						
	B	 W2 centre open to pressure	High flow	490	390	21 / 27	3	8	-0.95	8	R502A2B70MA00F1
			ISO subbase	390	390						
	E	 W3 centre open to exhaust	High flow	430	530	36 / 21	3	8	-0.95	8	R502A2B50MA00F1
			ISO subbase	390	470						

Pp = Piloting pressure

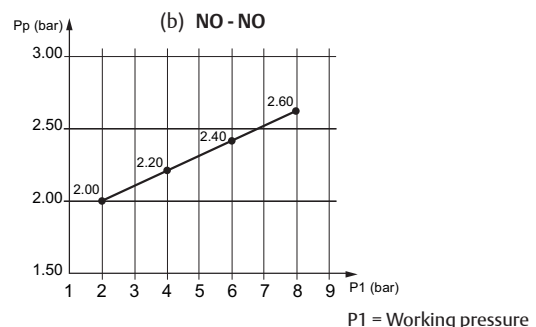
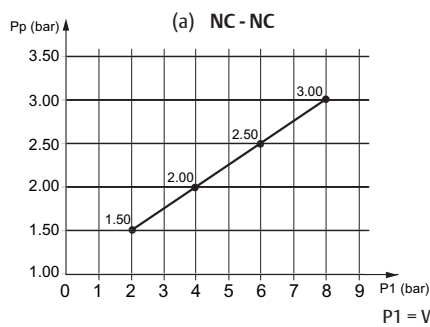
Pp = Piloting pressure

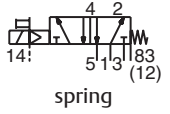
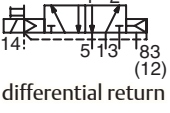
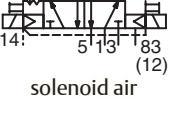

01443CB-2021/R01  
Availability, design and specifications are subject to change without notice. All rights reserved.

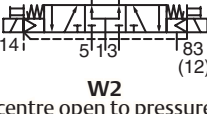
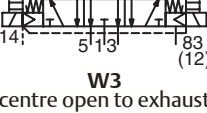
SPOOL VALVE, SPOOL AND SLEEVE TECHNOLOGY, WITH IMPULSE MANUAL OPERATOR													
5/2	S	 spring	High flow subbase	470	530	16 / 49	2	8	-0.95	8	<b>R502A1B10MA00F1</b>		
			ISO subbase	410	390								
	M	 differential return	High flow subbase	470	530	11 / 26	1.5	8	-0.95	8		<b>R502A1BN0NA00F1</b>	
			ISO subbase	410	390								
	J	 solenoid air	High flow subbase	470	530	16 / 16	2	8	-0.95	8			<b>R502A1B40MA00F1</b>
			ISO subbase	410	390								
5/3	G	 <b>W1</b> closed centre position	High flow subbase	420	440	12 / 12	1.5	8	-0.95	8	<b>R502A1B60MA00F1</b>		
			ISO subbase	360	350								
	B	 <b>W2</b> centre open to pressure	High flow subbase	420	430	13 / 23	1.5	8	-0.95	8		<b>R502A1B70MA00F1</b>	
			ISO subbase	370	350								
	E	 <b>W3</b> centre open to exhaust	High flow subbase	380	500	23 / 13	1.5	8	-0.95	8			<b>R502A1B50MA00F1</b>
			ISO subbase	340	350								

(\*) Ensure that compatibility of materials in contact with fluids is verified.

## Plug in Valve

### Dimensions (mm)

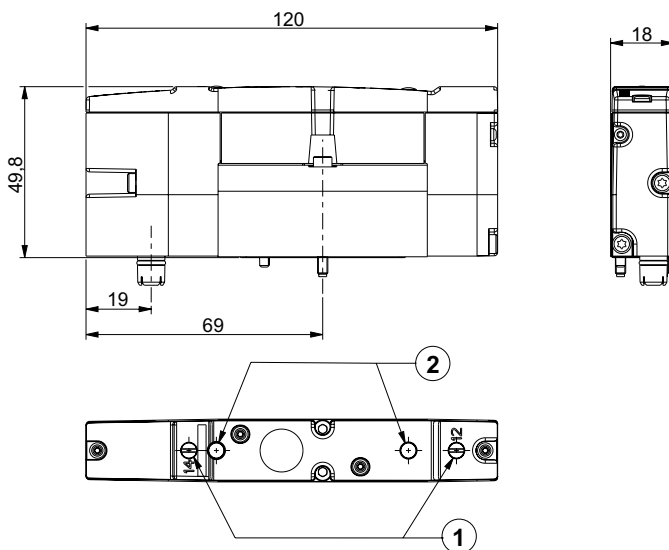

Configurator - CAD Files

<b>weight</b> (kg)
0.169

**Assembly kits**

**25 or 37 Pin Sub-D**

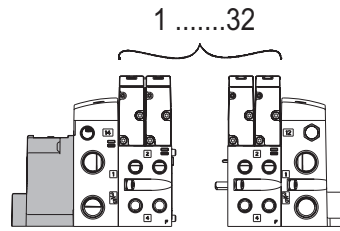

**1-32 Terminal Strip**

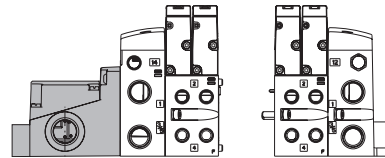

**19 Pin Round Connector**

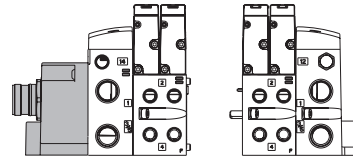

**26 Pin Round Connector**

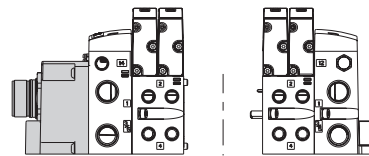

**Kit d'assemblage avec électronique G3 et modules d'E/S**

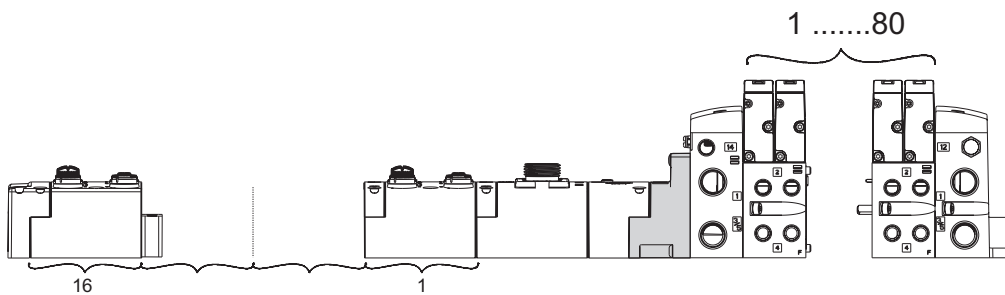

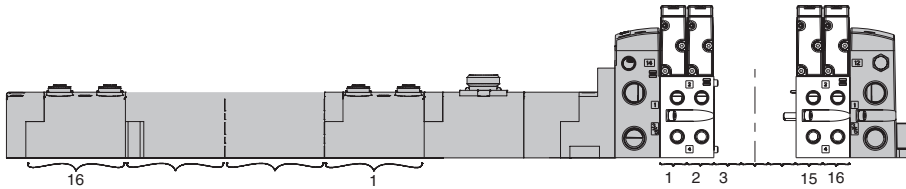
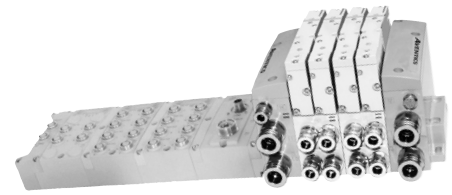

## Manifold assemblies kit (Electronic + End plate)

Configurator - CAD Files

**PRODUCT CODE**  
G 502 A V 3 2 2 0 0 V A00

**Thread connection**

- G = ISO 228/1
- 8 = NPT (contact us)
- K = Push-in connectors

**Product series**

502 (18 mm valve)

**Revision letter**

A = Initial release

**Product type**

V = Valve Manifold Assembly

**Electronics**

- 8 = 580 Fieldbus Electronics
- D = CHARMS Electronics
- 3 = G3 Fieldbus Electronics
- J = 25 Pin Sub-D Connector
- M = 37 Pin Sub-D Connector
- Q = 19 Pin Round Connector
- R = 26 Pin Round Connector
- T = Terminal Strip 1-32
- Z = Fanuc Robot End Effector
- 0 = No Electronics

**Number of Valve Stations**

- |              |              |           |           |
|--------------|--------------|-----------|-----------|
| B = 2/34/66  | L = 12/44/76 | V = 22/54 | 7 = 32/64 |
| D = 4/36/68  | N = 14/46/78 | X = 24/56 |           |
| F = 6/38/70  | P = 16/48/80 | Z = 26/58 |           |
| H = 8/40/72  | R = 18/50    | 3 = 28/60 |           |
| J = 10/42/74 | T = 20/52    | 5 = 30/62 |           |

**Options**

- A00 = Standard (no options)
- MUF = Muffler in End Plates
- DRM = DIN Rail Mount
- DWM = DIN Rail Mount with Muffler
- 14X = External pilot supply from port 14
- D12 = External pilot supply from port 14 and Muffler in End Plates
- D14 = External pilot supply from port 14 and DIN Rail Mount
- F06 = External pilot supply from port 14 Muffler in End Plates and DIN Rail Mount

**End Plate Style**

V = Vertical

**Second Valve Series**

- 0 = No Second Valve Series
- 1 = 11 mm Valve

**Valve Station Adder**

- 0 = No Adder
- 1 = 32+
- 2 = 64+

**End Plate Port Size (1-3-5)**

- Used with the first digit «G» or «8»:
- 3 = 3/8 (manifold base)
- Used with the first digit «K»:
- K = 8 x 10 mm (push-in connector)
- M = 10 x 12 mm (push-in connector)

### Maximum Solenoid Outputs

Terminal Strip 1-32	25 Pin Sub-D Connector	37 Pin Sub-D Connector	19 Pin Round Connector	26 Pin Round Connector
32	22	32	16	22

\*Note: Maximum number of valve stations is determined by:

- The electrical connection type.
- The valve type: single and/or double solenoid valves

01443GB-2021/R01 Availability, design and specifications are subject to change without notice. All rights reserved.

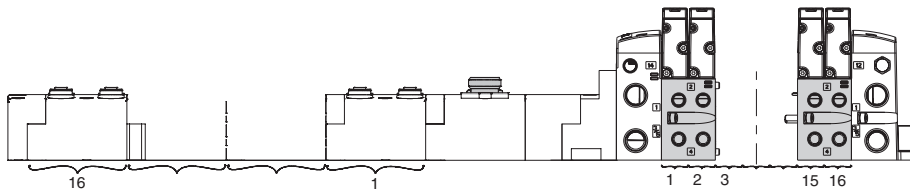

Configurator - CAD Files

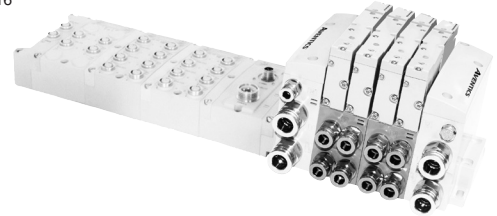

**Subbases**

**PRODUCT CODE**

**G 502 A M S2 2 M A00 1 0**

**Thread connection**

- G = ISO 228/1
- 8 = NPT (contact us)
- K = Push-in connectors

**Product series**

502 (18 mm valve)

**Revision letter**

A = Initial release

**Product type**

- M = Manifold base
- Z = Mid station supply
- F = 32+ Solenoid Manifold Subbase

**Mounting**

- S2 = Manifold base, 2 stations, side port, single Z-Board™
- M2 = Manifold base, 2 stations, side port, double Z-Board™
- V2 = Manifold base, 2 stations, side port
- M4 = 32+ Manifold Sub Base, 4 Stations, Side Ports, Double Z-Board™

**Interface**

- 1 = Pneumatic high flow
- 2 = ISO 15407-2 (18 mm)

**Options**

- A00 = Standard (internal pilot)
- 14X = External pilot supply from port 14
- 83H = Pilot Separation from Station 1
- 83J = Pilot Separation from Station 2

**Wiring option**

- M = Plug-in
- T = 32+ Solenoid Auxiliary Power (used with M4 and F)
- V = +24 V DC Separation at First Station
- W = +24 V DC Separation at Second Station

**Port connection (2-4)**

- Used with the first digit «G» or «8»:*
- 1 = 1/8 (female thread only)
  - 3 = 3/8 (Used for Dual Flow only)
  - 4 = 1/2 (Used for Dual Flow only)
- Used with the first digit «K»:*
- F = 4 x 6 mm [push-in connector only]
  - H = 6 x 8 mm [push-in connector only]

**Dimensions (mm)**

**Plug in Valve Mounted**

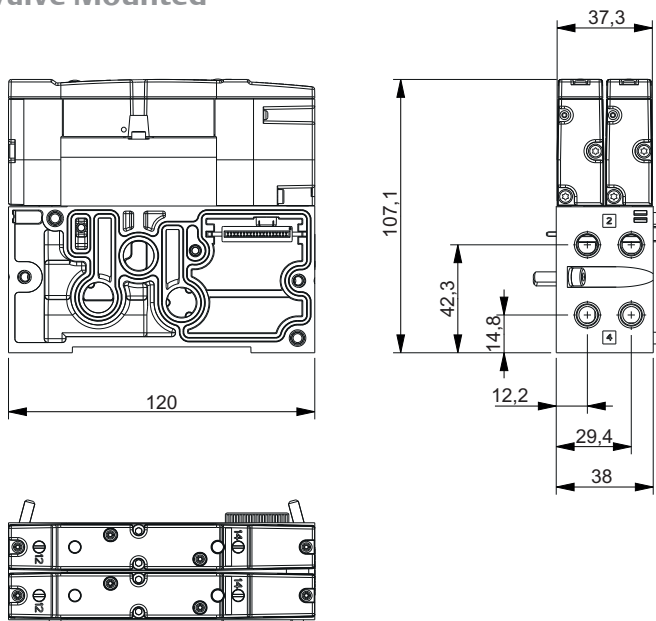

Configurator - CAD Files

**weight**  
**(kg)**

0.661

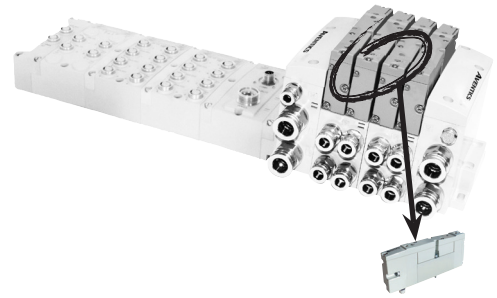
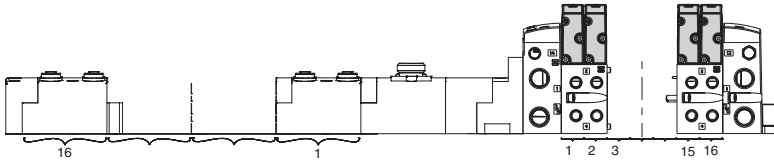

## Valves

### PRODUCT CODE

**R 502 A 2 B 1 0 M A00 F1**

**Thread connection**  
R = Pad mount

**Product series**  
502 (18 mm valve)

**Revision letter**  
A = Initial release

**Actuation**  
1 = Spool and sleeve  
2 = Rubber packed

**Valve type**  
B = Solenoid pilot  
(With impulse manual operator)

**Function**  
A = 2x3/2 NO, dual 3-way (Rubber packed)  
D = 2x3/2 NC, dual 3-way (Rubber packed)  
N = 5/2, Differential air return  
1 = 5/2, spring return  
4 = 5/2, solenoid air return  
5 = 5/3, W3, open center to exhaust  
6 = 5/3, W1, center closed  
7 = 5/3, W2, open center to pressure

Configurator - CAD Files

**Voltage - class**  
F1 = 24 V DC - class F

**Options**  
A00 = Standard (No option)  
With impulse manual operator <sup>(1)</sup>  
11B = With maintained manual operator  
11M = Without manual operator

**Electrical interface**  
M = Plug-in (with LED indicator / DC)

<sup>(1)</sup> Used external spool valves  
(internal/external supply configured in  
the end plate kits).

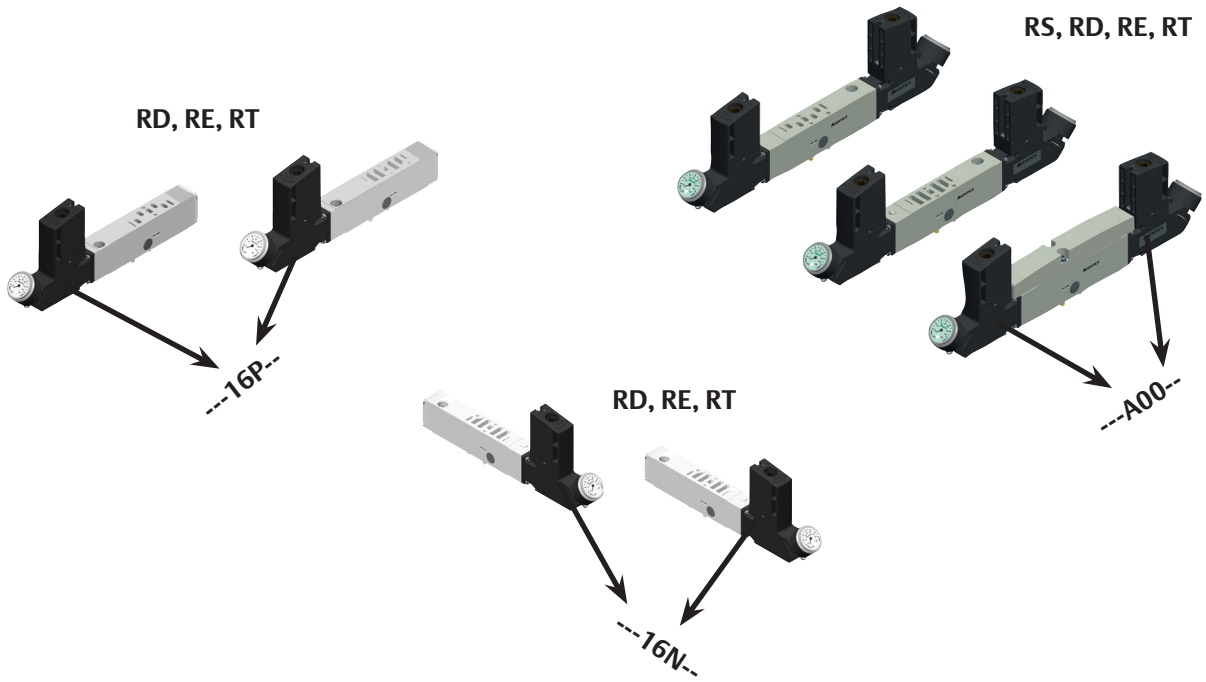

**Regulators**

Configurator - CAD Files

**PRODUCT CODE**

**R 502 A R - - - J - - 0**

**Thread connection**  
R = Pad mount

**Product series**  
502 (18 mm valve)

**Revision letter**  
A = Initial release

**Product type**  
R = Pressure regulator

**Type régulateur**  
S = Single regulator - Pressure to port 1

**D** = Regulator- Pressure to ports 5 & 3

**E** = Regulator - Pressure to ports 4 & 2, without valve

**T** = Regulator - Pressure to ports 1 & 3, 2 pressure selector

**Interface**  
1 = Pneumatic high flow  
2 = ISO 15407-2

**Options**  
A00 = Standard (no options)  
16N = Jumper on 14 end  
16P = Jumper on 12 end  
61Y = Regulator with Gauge Extension Fitting  
63L = 16P + 61Y  
63M = 16N + 61Y

**Wiring option**  
J = Plug-in

**Gauge type**  
2 = Gauge scale (bar)

**Plage de pression**  
1 = 0.7 to 9 bar  
3 = 0.2 to 2 bar  
4 = 0.3 to 4 bar

01443GB-2021/R01  
Availability, design and specifications are subject to change without notice. All rights reserved.



## Adaptor Plate Kits

The kits include the adapter plate, transfer board, gasket, screws.  
Individual end plates for the 502 and 503 are not included.  
This adaptor allows the transition from the 503 to the 502 series.

### EXAMPLE ORDERS:

Adapter plate kit:	G503AVJD332VA00
Valves:	R503A2B40MA00F1
	R503A2B40MA00F1
	G503AMM22MA0010
	R502A1B40MA00F1
	R502A1B40MA00F1
	G502AMM21MA0010
and mounting:	ASSEMBLED

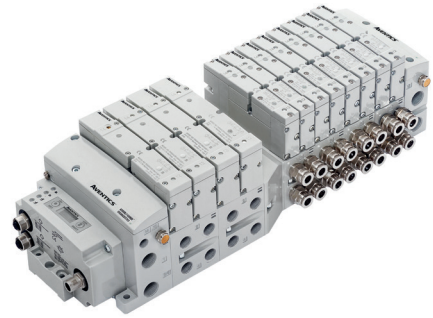

### Adaptor Plate Kit with Standard End Plates (ISO 15407-2 + High Flow)

Description	Catalog number
503 with 3/8 G-tap to 502	G503AT429964003

### Adaptor Plate Kit with Standard End Plates (ISO 15407-1)

Description	Catalog number
503 with 3/8 G-tap to 502	G503AT429964004

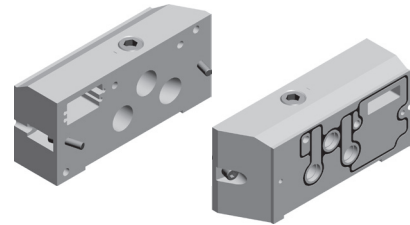

## Dimensions (mm)

### 503 to 502

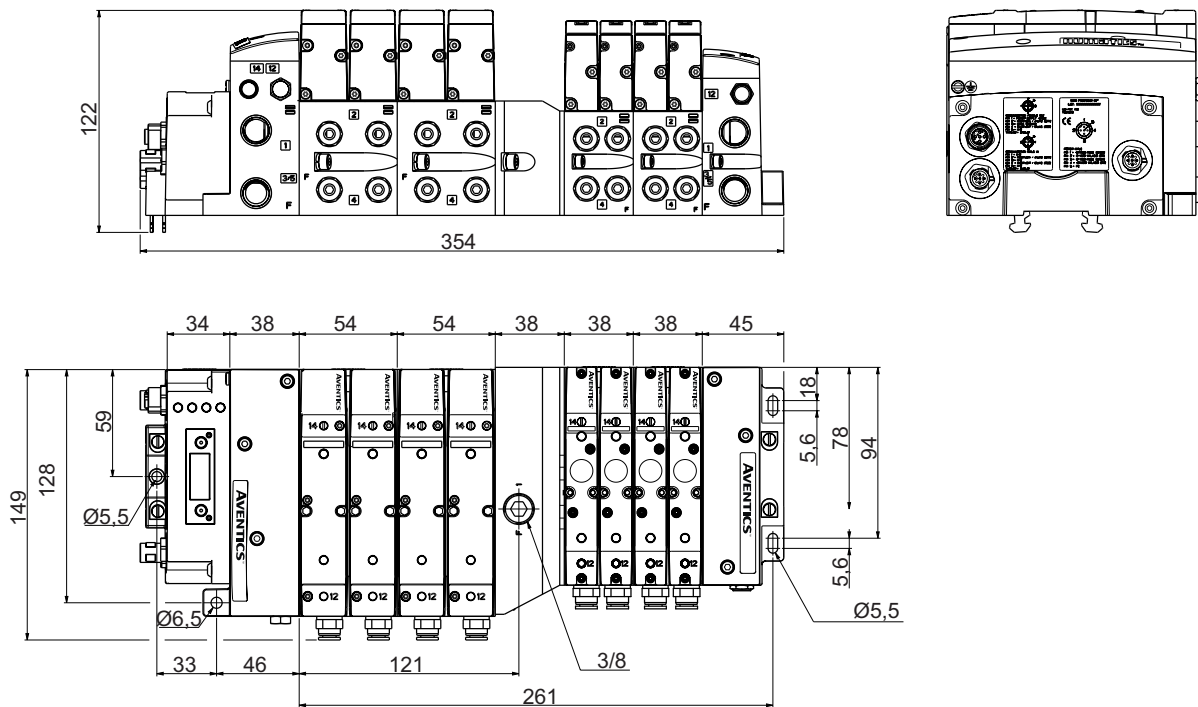

01443GB-2021/R01  
Availability, design and specifications are subject to change without notice. All rights reserved.

