

**ASCO
numatics™**

INSTALLATION AND MAINTENANCE INSTRUCTIONS	EN
INSTRUCTIONS D'INSTALLATION ET DE MAINTENANCE	FR
INBETRIEBNAHME - UND WARTUNGSANLEITUNG	DE
INSTRUCCIONES DE PUESTA EN MARCHA Y MANTENIMIENTO	ES
ISTRUZIONI DI MESSA IN SERVIZIO E MANUTENZIONE	IT
ALGEMENE INSTALLATIE- EN ONDERHOUDSINSTRUCTIES	NL
INSTALLASJONS- OG VEDLIKEHOLDSINSTRUKSER	NO
INSTALLATIONS- OCH UNDERHÅLLSINSTRUKTIONER	SE
ASENNUS - JA HUOLTO-OHJEET	FI
INSTALLATIONS - OG VEDLIGEHOIDSANVISNINGER	DK
INSTRUÇÕES DE INSTALAÇÃO E MANUTENÇÃO	PT
ΟΔΗΓΙΕΣ ΤΟΠΟΘΕΤΗΣΗΣ ΚΑΙ ΣΥΝΤΗΡΗΣΗΣ	GR
POKRYTY PRO INSTALACI A ÚDRŽBU	CZ
INSTRUKCJA MONTAŻU I KONSERWACJI	PL
TELEPÍTÉSI ÉS KARBANTARTÁSI ÚTMUTATÓ	HU
Инструкция по установке и обслуживанию	RU
설치 및유지 관리 지침	KR

502

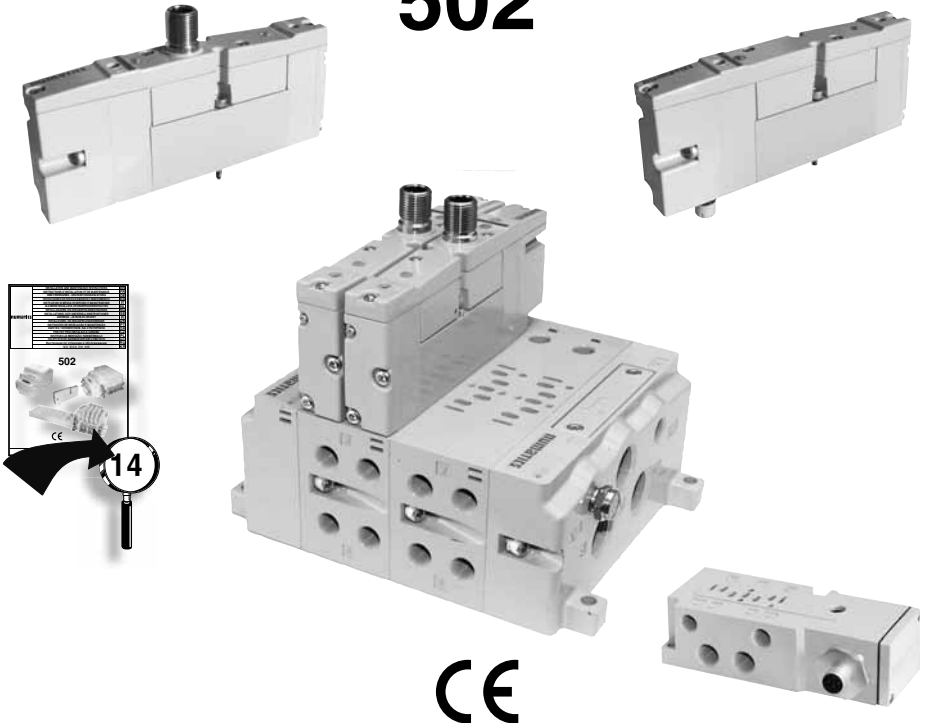

**ASCO
numatics™**
CE
(24 V DC)

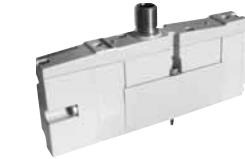

ISO 15407-1 18 mm

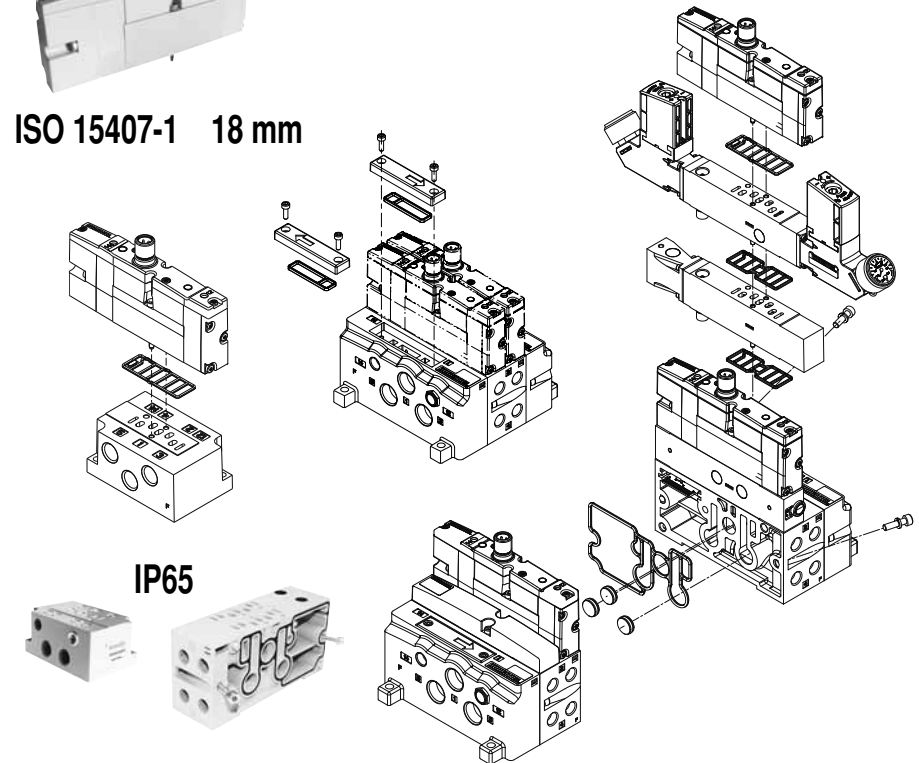

IP65









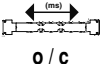

(24 V DC)

(24 V DC)



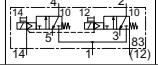

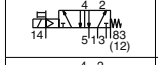
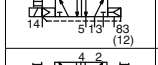
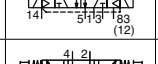
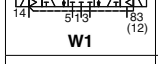

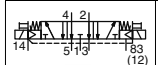

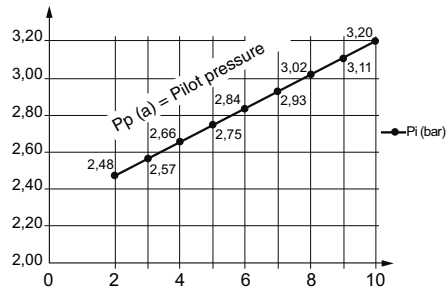

ISO 15407-2 18 mm

IP65

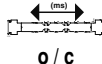
ASCO numatics™	rated flow  l/min 6,3 bar l/min (ANR)		 o / c (ms)	 (23°C) 14 P _p (bar)		 P (bar)			
	1→2 1→4	2→3 4→5		min.	max.  	min.	max. (PS) =		
(14) (12)									
 (Rubber packed)									
2 x 3/2 NC		500	440	42 / 22	3,5 (a)	10	8	2	10/8
2 x 3/2 NO		500	440	17 / 27	3,5 (b)	10	8	2	10/8
5/2		500	470	21 / 36	3	10	8	-0,95	10/8
		500	470	21 / 37	2,5	10	8	-0,95	10/8
		500	470	15 / 15	2	10	8	-0,95	10/8
5/3		500	460	18 / 21	3,5	10	8	-0,95	10/8
		440	410	25 / 37	3,5	10	8	-0,95	10/8
		440	420	32 / 24	3,5	10	8	-0,95	10/8



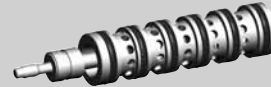
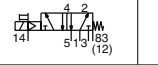
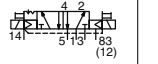

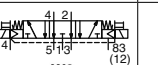
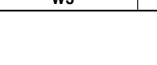

(a) NC - NC
P_p = 0,09 x P(1) + 2,3 bar

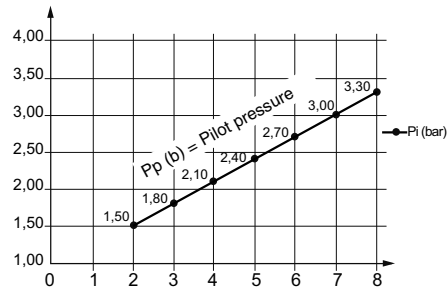

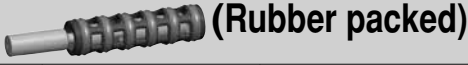
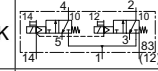
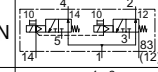
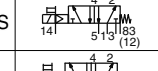
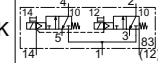
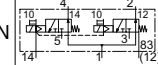
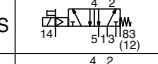
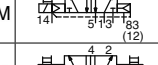
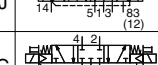
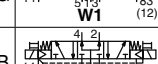
ASCO numatics™	rated flow  l/min 6,3 bar l/min (ANR)		 o / c (ms)	 (23°C) 14 P _p (bar)		 P (bar)			
	1→2 1→4	2→3 4→5		min.	max.  	min.	max. (PS) =		
(14) (12)									
 (Spool & Sleeve)									
5/2		410	390	16 / 49	2	10	8	-0,95	10/8
		410	390	12 / 12	2	10	8	-0,95	10/8
5/3		-	-	-	2	10	8	-0,95	10/8
		-	-	-	2	10	8	-0,95	10/8
		-	-	-	2	10	8	-0,95	10/8

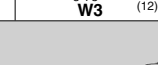
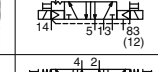
(b) NO - NO
P_p = 0,30 x P(1) + 0,9 bar

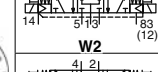
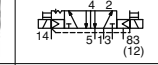

ASCO numatics™		15-DIGIT PRODUCT CODE 			
		with impulse manual operator ISO 15407-1 26 mm	with maintained manual operator ISO 15407-1 26 mm	without manual operator ISO 15407-1 26 mm	
(14)	(12)	 (Rubber packed)			
2 x 3/2 NC	K		R502A2BD0N83BF1 (R502A2BD0N82PF1) (b)	R502A2BD0N82MF1 (R502A2BD0N69PF1) (b)	R502A2BD0N82NF1 (R502A2BD0N69NF1) (b)
	N		R502A2BA0N83BF1	R502A2BA0N82MF1	R502A2BA0N82NF1
	5/2	S		R502A2B10N83BF1 (R502A2B10N82PF1) (b)	R502A2B10N82MF1 (R502A2B10N69PF1) (b)
M			R502A2BN0N83BF1	R502A2BN0N82MF1	R502A2BN0N82NF1
J			R502A2B40N83BF1 (R502A2B40N82PF1) (b)	R502A2B40N82MF1 (R502A2B40N69PF1) (b)	R502A2B40N82NF1 (R502A2B40N69NF1) (b)
5/3	G		R502A2B60N83BF1 (R502A2B60N82PF1) (b)	R502A2B60N82MF1 (R502A2B60N69PF1) (b)	R502A2B60N82NF1 (R502A2B60N69NF1) (b)
	B		R502A2B70N83BF1 (R502A2B70N82PF1) (b)	R502A2B70N82MF1 (R502A2B70N69PF1) (b)	R502A2B70N82NF1 (R502A2B70N69NF1) (b)
	E		R502A2B50N83BF1 (R502A2B50N82PF1) (b)	R502A2B50N82MF1 (R502A2B50N69PF1) (b)	R502A2B50N82NF1 (R502A2B50N69NF1) (b)
 (Spool & Sleeve)					
5/2			R502A1B10N83BF1 (R502A1B10N82PF1) (b)	R502A1B10N82MF1 (R502A1B10N69PF1) (b)	R502A1B10N82NF1 (R502A1B10N69NF1) (b)
			R502A1B40N83BF1 (R502A1B40N82PF1) (b)	R502A1B40N82MF1 (R502A1B40N69PF1) (b)	R502A1B40N82NF1 (R502A1B40N69NF1) (b)
5/3			R502A1B70N83BF1 (R502A1B70N82PF1) (b)	R502A1B70N82MF1 (R502A1B70N69PF1) (b)	R502A1B70N82NF1 (R502A1B70N69NF1) (b)
			R502A1B50N83BF1 (R502A1B50N82PF1) (b)	R502A1B50N82MF1 (R502A1B50N69PF1) (b)	R502A1B50N82NF1 (R502A1B50N69NF1) (b)
					









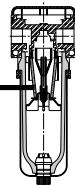

(b) Internal piloting (internal supply).

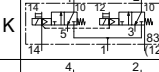
AIR QUALITY [ISO 8573-1 (2010)]: Level 7.4.4

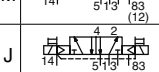
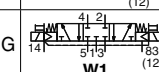
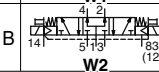
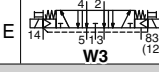
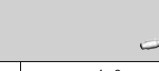

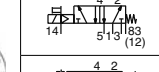
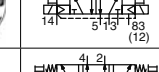
40 μm ↔ 5 μm

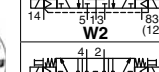
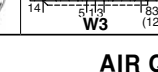

ASCO numatics™		15-DIGIT PRODUCT CODE 			
		with impulse manual operator ISO 15407-2 26 mm	with maintained manual operator ISO 15407-2 26 mm	without manual operator ISO 15407-2 26 mm	
(14)	(12)	 (Rubber packed)			
2 x 3/2 NC	K		R502A2BD0MA00F1	R502A2BD0M11BF1	R502A2BD0M11MF1
	N		R502A2BA0MA00F1	R502A2BA0M11BF1	R502A2BA0M11MF1
	5/2	S		R502A2B10MA00F1	R502A2B10M11BF1
M			R502A2BN0MA00F1	R502A2BN0M11BF1	R502A2BN0M11MF1
J			R502A2B40MA00F1	R502A2B40M11BF1	R502A2B40M11MF1
5/3	G		R502A2B60MA00F1	R502A2B60M11BF1	R502A2B60M11MF1
	B		R502A2B70MA00F1	R502A2B70M11BF1	R502A2B70M11MF1
	E		R502A2B50MA00F1	R502A2B50M11BF1	R502A2B50M11MF1
 (Spool & Sleeve)					
5/2			R502A1B10MA00F1	R502A1B10M11BF1	R502A1B10M11MF1
			R502A1B40MA00F1	R502A1B40M11BF1	R502A1B40M11MF1
5/3			R502A1B70MA00F1	R502A1B70M11BF1	R502A1B70M11MF1
			R502A1B50MA00F1	R502A1B50M11BF1	R502A1B50M11MF1
					

AIR QUALITY [ISO 8573-1 (2010)]: Level 7.4.4



40 μm ↔ 5 μm

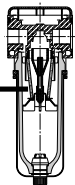



<p>G502AA3A20A0030</p>		<p>1-2-3-4-5 = 5 x G 3/8 12 = G 1/8</p>	
<p>US ▶ 8502AA3A20A0030</p>		<p>1-2-3-4-5 = 5 x NPT 3/8 12 = NPT 1/8</p>	
<p>G502AA3A2014X30</p>		<p>1-2-3-4-5 = 5 x G 3/8 12 = G 1/8 14 = G 1/8</p>	
<p>US ▶ 8502AA3A2014X30</p>		<p>1-2-3-4-5 = 5 x NPT 3/8 12 = NPT 1/8 14 = NPT 1/8</p>	

<p>G502AA3A2M56Y20</p>		<p>1-2-3-4-5 = 5 x G 3/8 12 = G 1/8</p>	
<p>US ▶ 8502AA3A2M56Y20</p>		<p>1-2-3-4-5 = 5 x NPT 3/8 12 = NPT 1/8</p>	
<p>G502AA3A2M59W20</p>		<p>1-2-3-4-5 = 5 x G 3/8 12 = G 1/8 14 = G 1/8</p>	
<p>US ▶ 8502AA3A2M59W20</p>		<p>1-2-3-4-5 = 5 x NPT 3/8 12 = NPT 1/8 14 = NPT 1/8</p>	

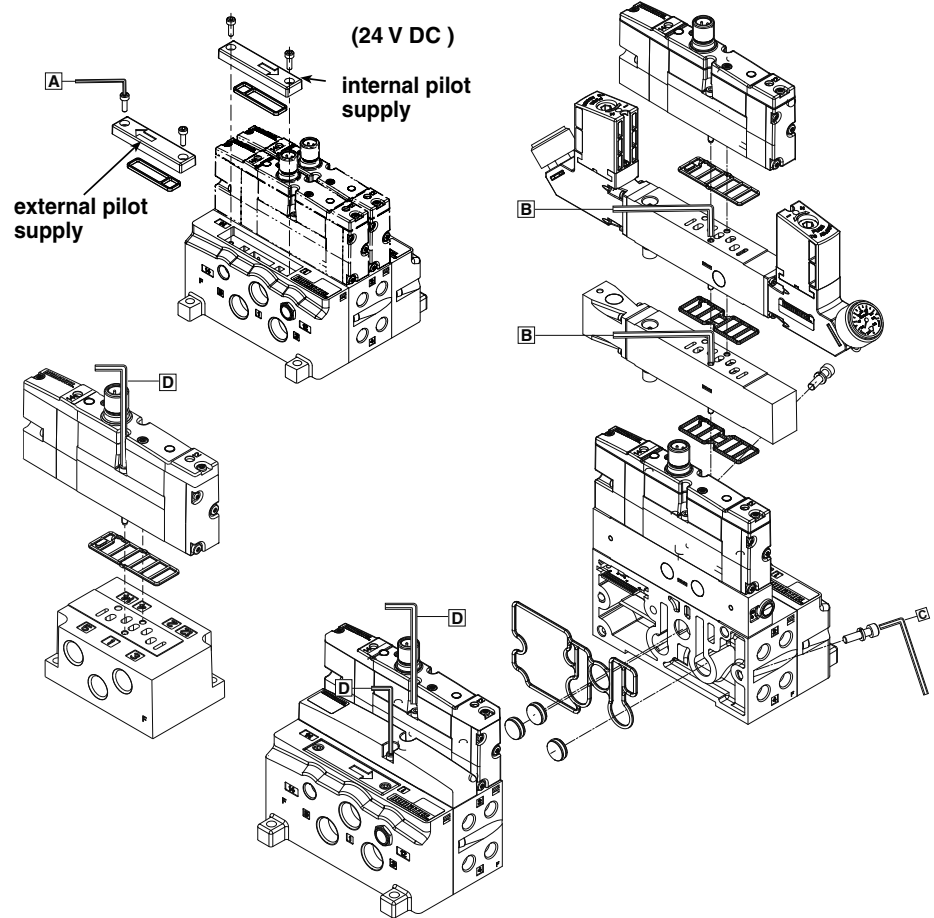
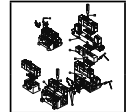

items	N.m	Inch.pounds
A	2 ±10%	17.7 ±1.8
B	1.2 ±10%	10.6 ±1.1
C	4.6 ±10%	40.7 ±4.1
D	2 ±10%	17.7 ±1.8

numatics

502

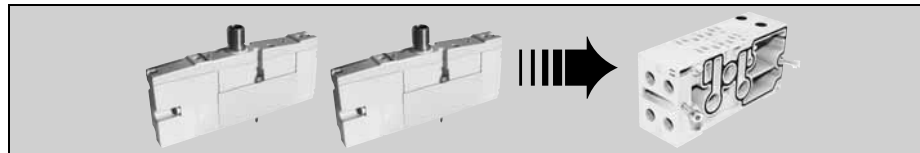

	G502AMV210A0030	4 x G 1/8		
US	8502AMV210A0030	4 x NPT 1/8		

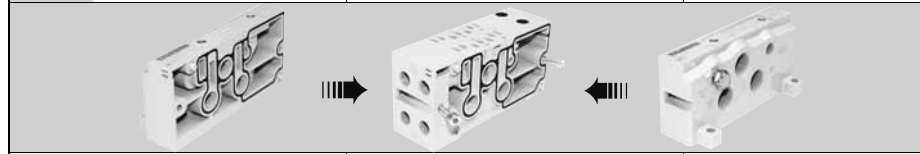

	G502AK431478004	3 x G 3/8 (1/3/5) 2 x G 1/8 (12/14)	
US	8502AK431478001	3 x NPT 3/8 (1/3/5) 2 x NPT 1/8 (12/14)	

P502AB431813001		
------------------------	--	--

P502AD431914001		+		•	1
P502AD431914002		+		•	3
P502AD431914003		+		•	5
P502AD431914004		+		•	1, 3
P502AD431914005		+		•	1, 5
P502AD431914006		+		•	3, 5
P502AD431914007		+		•	1, 3, 5

numatics

502

ISO 15407-1



	R502AY506752001	
--	------------------------	--

G1/4		G502AW506753002	
-------------	--	------------------------	--

G1/4		G502AX506753001	
-------------	--	------------------------	--

	R502AS506755001	
--	------------------------	--

numatics

502

0,7 .. 9 bar



0,7 .. 9 bar
ISO 15407-1



R502ARS120A0030	RS			
R502ARS12061Y30				
R502ARD12016P30	RD			
R502ARD12063L30				
R502ARD12016N30				
R502ARD12063M30				
R502ARD120A0030				
R502ARD12061Y30				
R502ARE12016P00	RE			
R502ARE12063L00				
R502ARE12016N00				
R502ARE12063M00				
R502ARE120A0000				
R502ARE12061Y00				
R502ART12016P30	RT			
R502ART12063L30				
R502ART12016N30				
R502ART12063M30				
R502ART120A0030				
R502ART12061Y30				

numatics

502

10 .. 130 psig



PSIG ► 10 .. 130 psig
ISO 15407-1

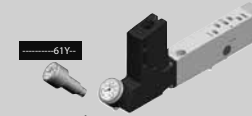

R502ARS110A0030	RS			
R502ARS11061Y30				
R502ARD11016P30	RD			
R502ARD11063L30				
R502ARD11016N30				
R502ARD11063M30				
R502ARD110A0030				
R502ARD11061Y30				
R502ARE11016N30	RE			
R502ARE11063L00				
R502ARE11016N00				
R502ARE11063M00				
R502ARE110A0000				
R502ARE11061Y00				
R502ART110A0030	RT			
R502ART11063L30				
R502ART11016N30				
R502ART11063M30				
R502ART110A0030				
R502ART11061Y30				

numatics	INSTALLATION AND MAINTENANCE INSTRUCTIONS	EN
	INSTRUCTIONS D'INSTALLATION ET DE MAINTENANCE	FR
	INBETRIEBNAHME - UND WARTUNGSANLEITUNG	DE
	INSTRUCCIONES DE PUESTA EN MARCHA Y MANTENIMIENTO	ES
	ISTRUZIONI DI MESSA IN SERVIZIO E MANUTENZIONE	IT
	ALGEMENE INSTALLATIE- EN ONDERHOUDSINSTRUCTIES	NL
	INSTALLASJONS- OG VEDLIKEHOLDSINSTRUKSER	NO
	INSTALLATIONS- OCH UNDERHÅLLSINSTRUKTIONER	SE
	ASENNUS - JA HUOLTO-OHJEET	FI
	INSTALLATIONS - OG VEDLIGEHOLDSANVISNINGER	DK
	INSTRUÇÕES DE INSTALAÇÃO E MANUTENÇÃO	PT
	ΟΔΗΓΙΕΣ ΤΟΠΟΘΕΤΗΣΗΣ ΚΑΙ ΣΥΝΤΗΡΗΣΗΣ	GR
	POKRYNY PRO INSTALACI A ÚDRŽBU	CZ
INSTRUKCJA MONTAŻU I KONSERWACJI	PL	
TELEPÍTÉSI ÉS KARBANTARTÁSI ÚTMUTATÓ	HU	
Инструкция по установке и обслуживанию	RU	
설치 및유지 관리 지침	KR	

502

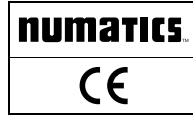
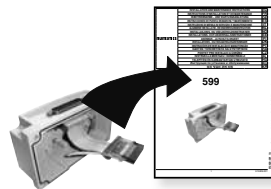
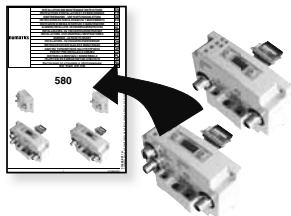
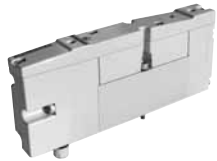

(24 V DC)



High flow

ISO 15407-2 / 18mm

SGL

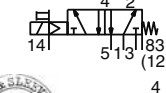
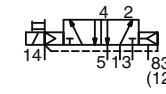
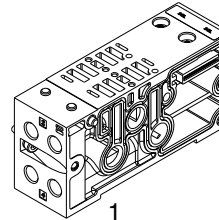

8 G 502AM**S2**GMA0010
K F H

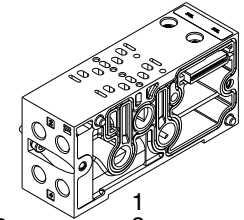

8 G 502AM**S2**GMA0020
K F H

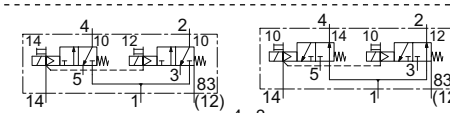

DBL

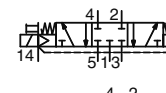
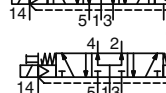
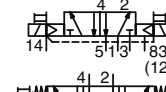
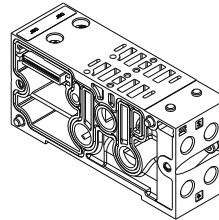

8 G 502AM**M2**GMA0010
K F H

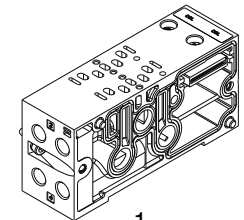

8 G 502AM**M2**GMA0020
K F H

Accessory Z-board™ Mid station supply

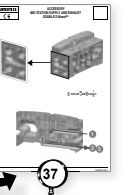

numatics				rated flow l/min 6,3 bar l/min (ANR)					
(14)	(12)			1→2 1→4	2→3 4→5	min.		min.	max. (PS) =
(Rubber packed)									
2 x 3/2 NC		High flow	650	600	42 / 22	3,5 (a)	8	2	10/8
	ISO	500	440						
2 x 3/2 NO		High flow	640	610	17 / 27	3,5 (b)	8	2	10/8
	ISO	500	440						
5/2		High flow	625	695	21 / 36	2,5	8	-0,95	10/8
	ISO	500	470						
		High flow	625	695	21 / 37	3	8	-0,95	10/8
	ISO	500	470						
		High flow	625	695	15 / 15	2	8	-0,95	10/8
	ISO	500	470						
5/3		High flow	590	660	18 / 21	3,5	8	-0,95	10/8
	ISO	500	460						
		High flow	540	530	25 / 37	3,5	8	-0,95	10/8
	ISO	440	410						
		High flow	500	550	32 / 24	3,5	8	-0,95	10/8
	ISO	440	420						



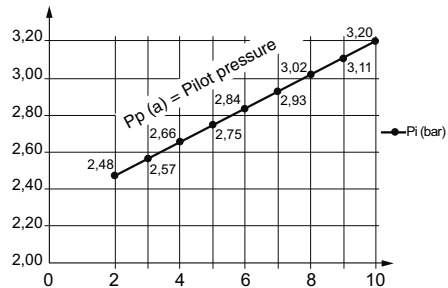



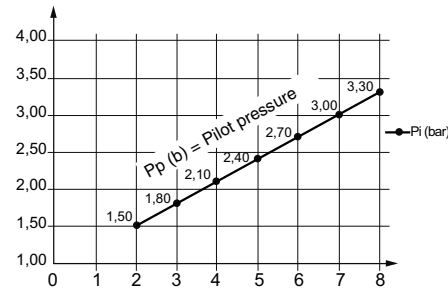



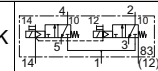
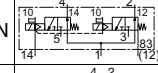

(a) NC - NC
Pp = 0,09 x P(1) + 2,3 bar

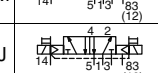
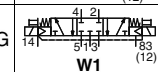

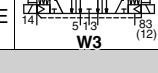
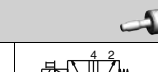
(b) NO - NO
Pp = 0,30 x P(1) + 0,9 bar

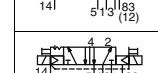
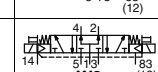

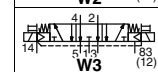
numatics				rated flow l/min 6,3 bar l/min (ANR)					
(14)	(12)			1→2 1→4	2→3 4→5	min.		min.	max. (PS) =
(Spool & Sleeve)									
5/2		High flow	470	530	16 / 49	2	8	-0,95	10/8
	ISO	410	390						
		High flow	470	530	16 / 16	2	8	-0,95	10/8
	ISO	410	390						
5/3		High flow	-	-	-	2	8	-0,95	10/8
	ISO	-	-						
		High flow	-	-	-	2	8	-0,95	10/8
	ISO	-	-						
		High flow	-	-	-	2	8	-0,95	10/8
	ISO	-	-						

numatics		15-DIGIT PRODUCT CODE 			
		with impulse manual operator	with maintained manual operator	without manual operator	
(14) (12)					
 (Rubber packed)					
2 x 3/2 NC	K		R502A2BD0MA00F1	R502A2BD0M11BF1	R502A2BD0M11MF1
2 x 3/2 NO	N		R502A2BA0MA00F1	R502A2BA0M11BF1	R502A2BA0M11MF1
5/2	S		R502A2B10MA00F1	R502A2B10M11BF1	R502A2B10M11MF1
	M		R502A2BN0MA00F1	R502A2BN0M11BF1	R502A2BN0M11MF1
	J		R502A2B40MA00F1	R502A2B40M11BF1	R502A2B40M11MF1
5/3	G		R502A2B60MA00F1	R502A2B60M11BF1	R502A2B60M11MF1
	B		R502A2B70MA00F1	R502A2B70M11BF1	R502A2B70M11MF1
	E		R502A2B50MA00F1	R502A2B50M11BF1	R502A2B50M11MF1
 (Spool & Sleeve)					
5/2			R502A1B10MA00F1	R502A1B10M11BF1	R502A1B10M11MF1
			R502A1B40MA00F1	R502A1B40M11BF1	R502A1B40M11MF1
5/3			R502A1B70MA00F1	R502A1B70M11BF1	R502A1B70M11MF1
			R502A1B50MA00F1	R502A1B50M11BF1	R502A1B0M11MF1
					

AIR QUALITY [ISO 8573-1 (2010)]: Level 7.4.4



40 μm ↔ 5 μm

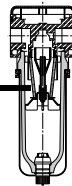

numatics
502

25 Pin Sub-D:
SGL = 22 max. / DBL = 11 max.
37 Pin Sub-D:
SGL = 32 max. / DBL = 16 max.

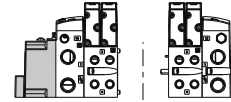

1-32 Terminal Strip:
SGL = 32 max. / DBL = 16 max.

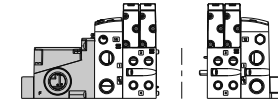

19 Pin Round Connector:
SGL = 16 max. / DBL = 8 max.

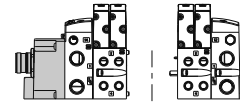

26 Pin Round Connector:
SGL = 22 max. / DBL = 11 max.

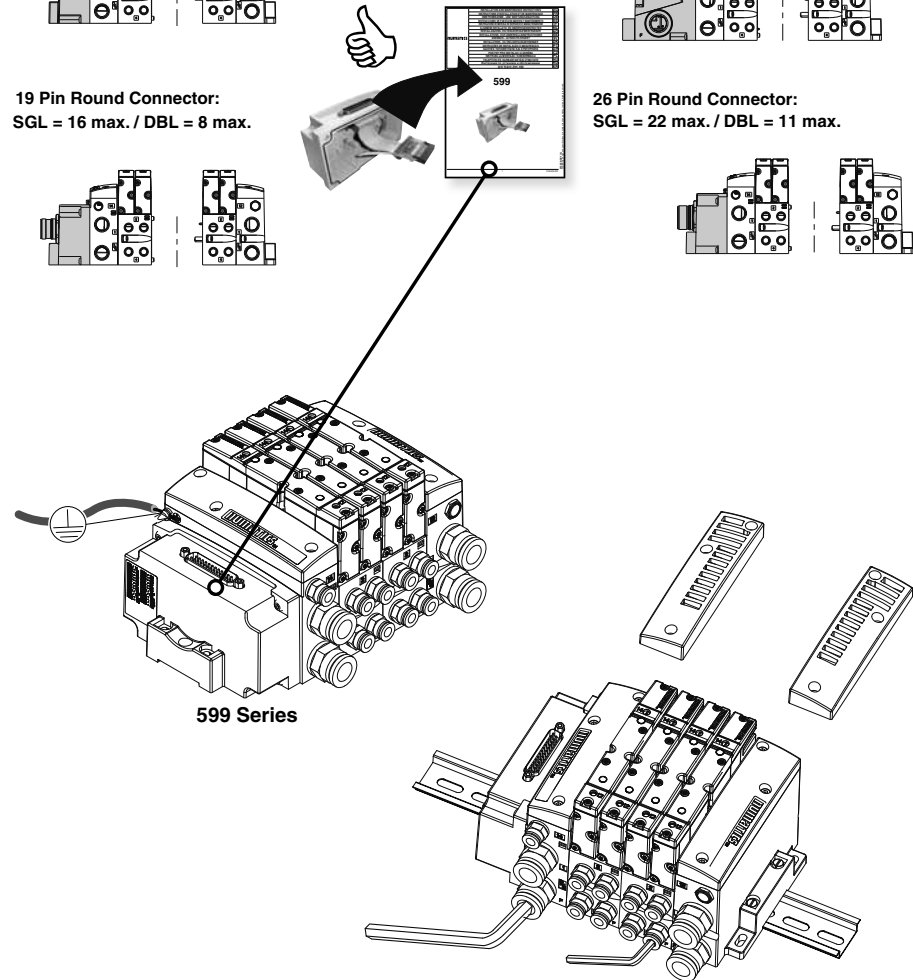
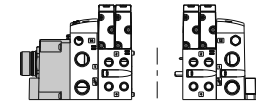

numatics
502

G3 → 502

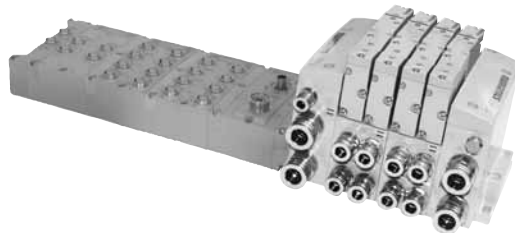
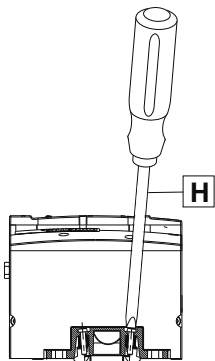
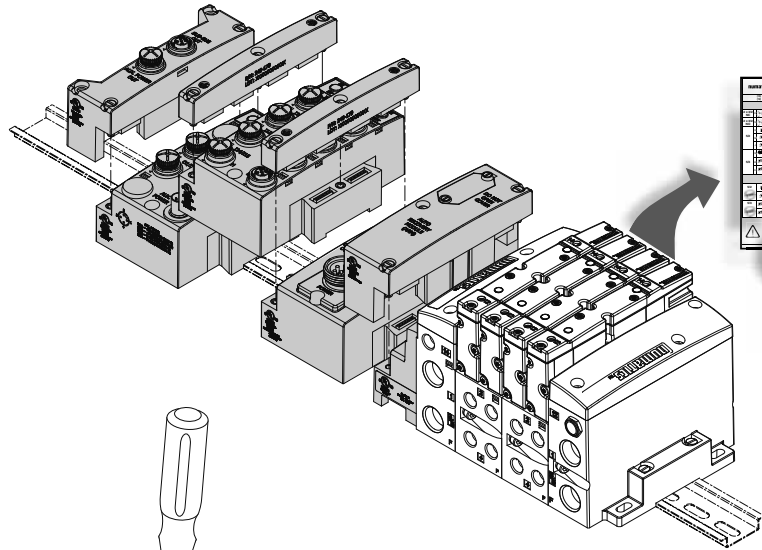
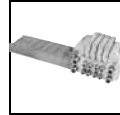

items	N.m	Inch.pounds
H	2.65	23.4

numatics
502



items	N.m	Inch.pounds
C	4.6 ±10%	40.7 ± 4.1
D	2.0 ±10%	17.7 ± 1.8
J	2.4 ±10%	21.0 ± 2.1

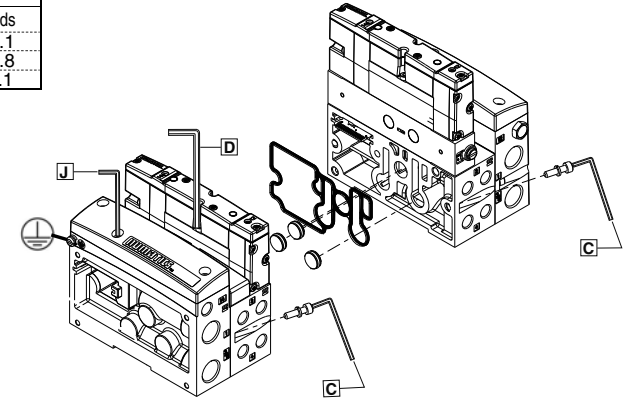

<p>P502AB431813001</p>		<p>(4) (12)(5) (1) (9)(14) (2)</p>
-------------------------------	--	------------------------------------

P502AD431914001		+		•	1
P502AD431914002		+		•	3
P502AD431914003		+		•	5
P502AD431914004		+		•	1, 3
P502AD431914005		+		•	1, 5
P502AD431914006		+		•	3, 5
P502AD431914007		+		•	1, 3, 5

numatics
502



			G502AK431477013	
			K502AK431477015	
			K502AK431477017	
			G502AK431477014	
			K502AK431477016	
			K502AK431477018	



			G502AK431477019	
			K502AK431477021	
			K502AK431477023	
			G502AK431477020	
			K502AK431477022	
			K502AK431477024	

numatics
502



			8502AK431477001	
			8502AK431477005	
			8502AK431477003	
			8502AK431477002	
			8502AK431477006	
			8502AK431477004	



			8502AK431477007	
			8502AK431477011	
			8502AK431477009	
			8502AK431477008	
			8502AK431477012	
			8502AK431477010	

numatics
502

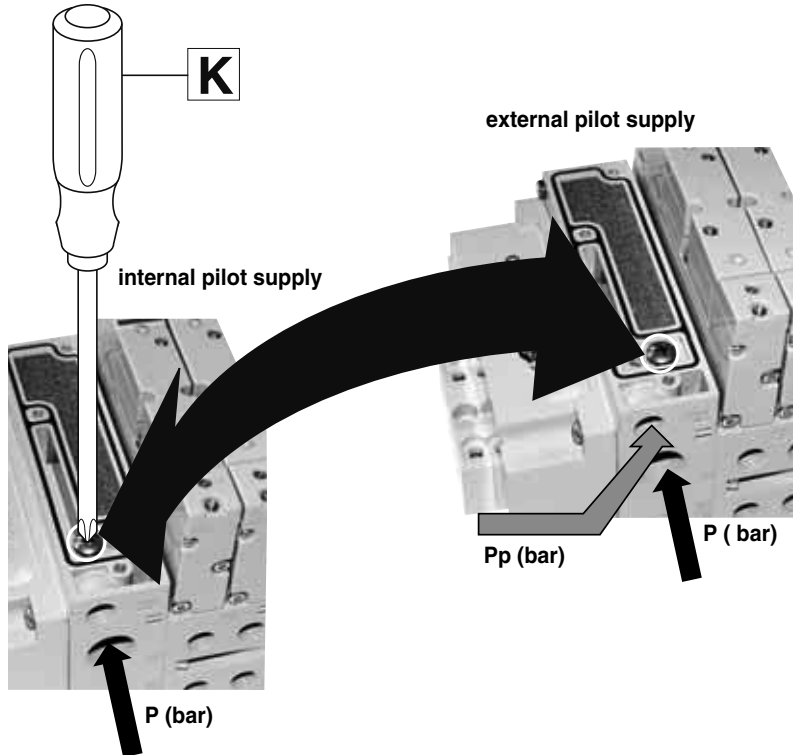
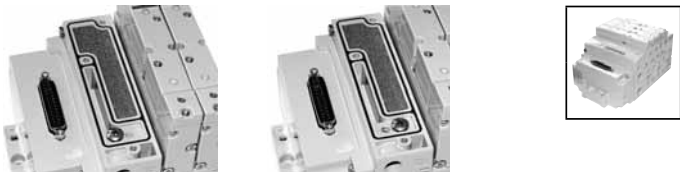

items	N.m	Inch.pounds
K	2,6 ±10%	23 ± 2.3

numatics
502

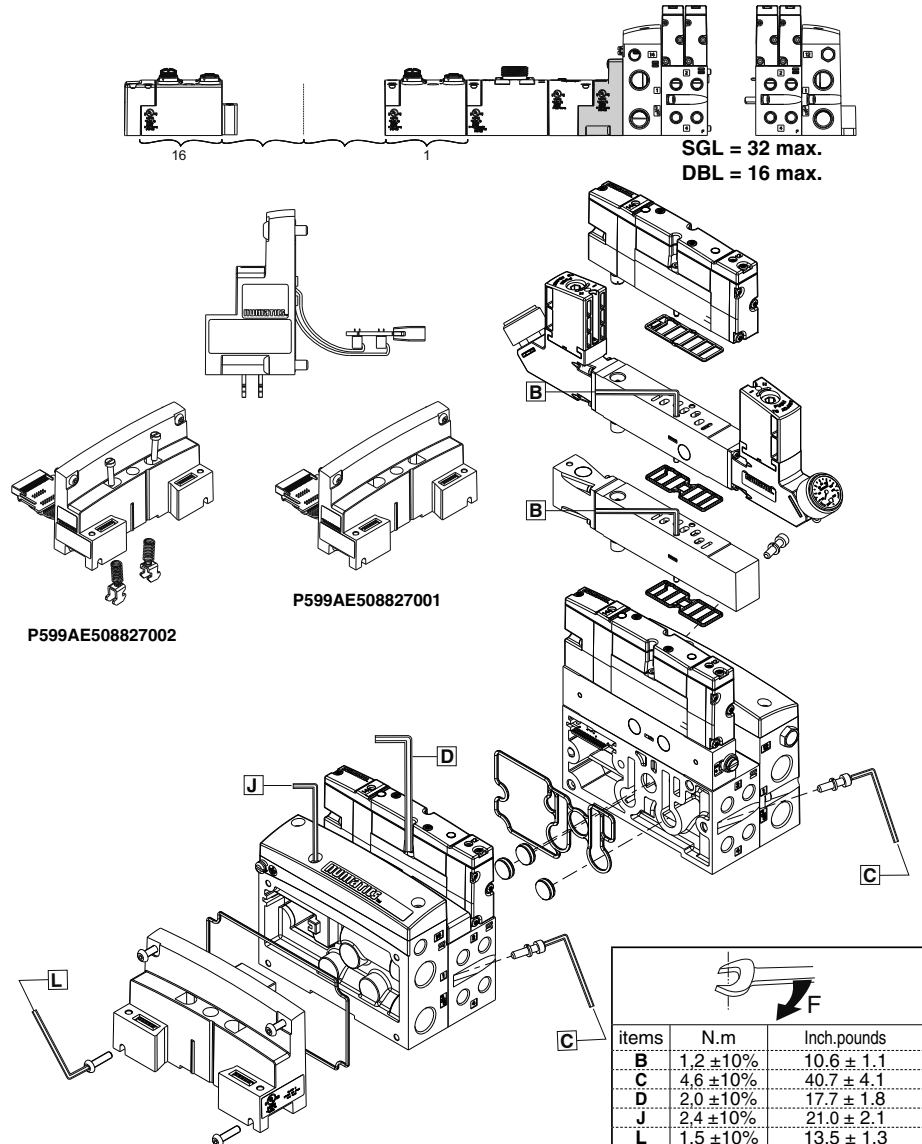

items	N.m	Inch.pounds
B	1,2 ±10%	10.6 ± 1.1
C	4,6 ±10%	40.7 ± 4.1
D	2,0 ±10%	17.7 ± 1.8
J	2,4 ±10%	21.0 ± 2.1
L	1,5 ±10%	13.5 ± 1.3

numatics
502

G3 / 580 / 599

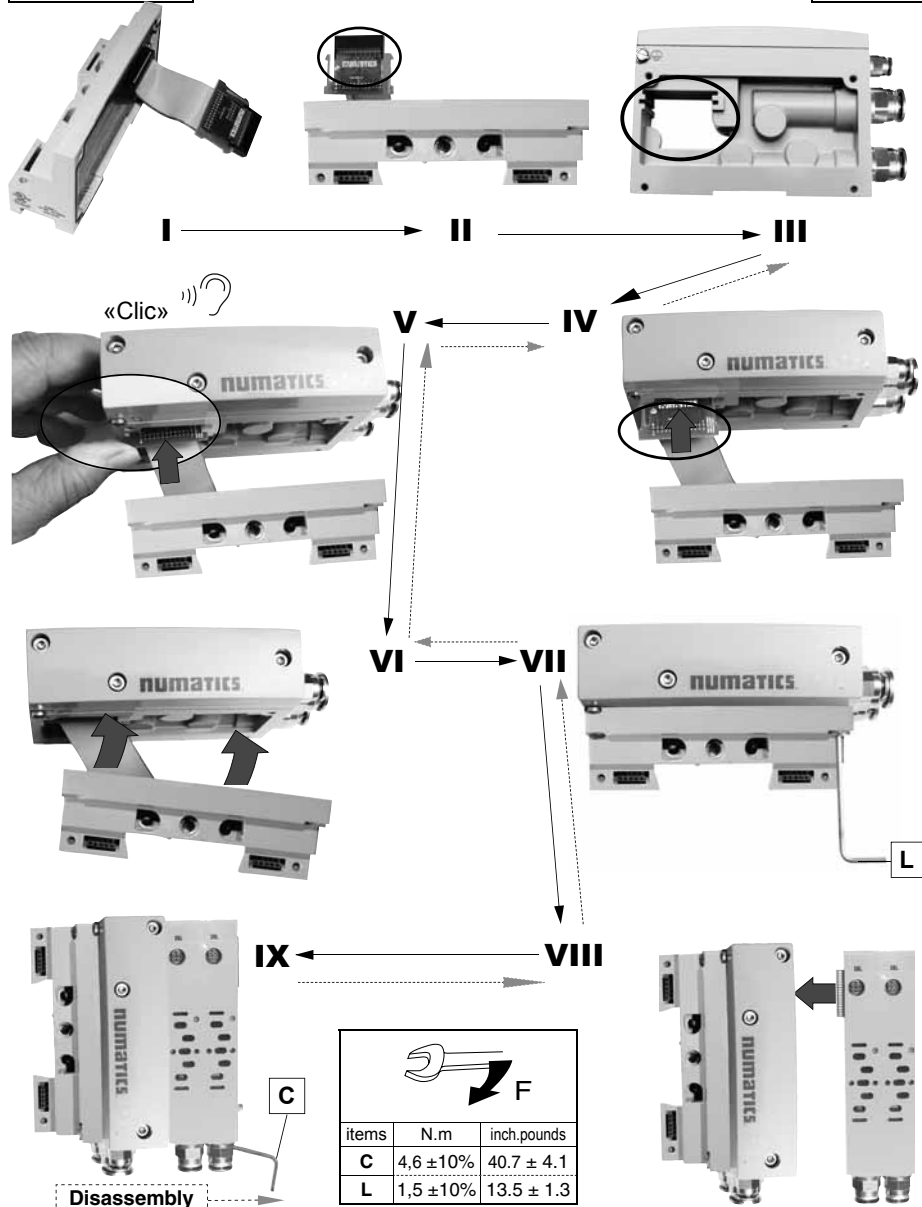

numatics
502



580

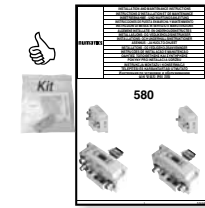









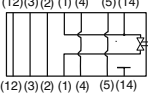

	CANopen®		POWERLINK
	DeviceNet™		Ethernet/IP™
	PROFIBUS-DP®		EtherCAT®
	EtherNET/IP™ DLR		PROFINET®
	SUB-BUS		

numatics

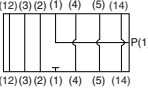
502

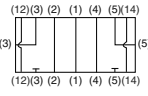
High flow

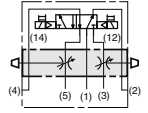

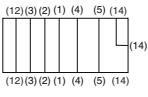







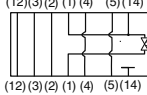

 <p>High flow</p>		<p>R502AY429409002</p>	 <p>(12)(3)(2) (1) (4) (5)(14) (12)(3)(2) (1) (4) (5)(14)</p>
	<p>G1/4 NPT 1/4</p> 	<p>G502AW428685004</p>	 <p>(12)(3)(2) (1) (4) (5) (14) (12)(3)(2) (1) (4) (5) (14) P(1)</p>
	<p>US ▶</p>	<p>8502AW428685004</p>	
	<p>G1/4 NPT 1/4</p> 	<p>G502AX428685002</p>	 <p>(12)(3) (2) (1) (4) (5)(14) (3) (12)(3) (2) (1) (4) (5)(14)</p>
	<p>US ▶</p>	<p>8502AX428685002</p>	
		<p>R502AS429395002</p>	 <p>(14) (12) (4) (5) (1) (3) (2)</p>
		<p>G502AP428685006</p>	 <p>(12)(3)(2) (1) (4) (5) (14) (12)(3)(2) (1) (4) (5) (14)</p>
	<p>US ▶</p>	<p>8502AP428685006</p>	

numatics

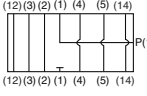
502

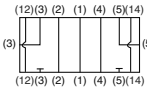
ISO 15407-2 18 mm

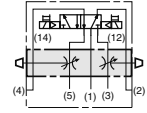

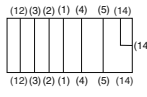
 <p>ISO 15407-2 18 mm</p>		<p>R502AY429409001</p>	 <p>(12)(3)(2) (1) (4) (5)(14) (12)(3)(2) (1) (4) (5)(14)</p>
	<p>G1/4 NPT 1/4</p> 	<p>G502AW428685003</p>	 <p>(12)(3)(2) (1) (4) (5) (14) (12)(3)(2) (1) (4) (5) (14) P(1)</p>
	<p>US ▶</p>	<p>8502AW428685003</p>	
	<p>G1/4 NPT 1/4</p> 	<p>G502AX428685001</p>	 <p>(12)(3) (2) (1) (4) (5)(14) (3) (12)(3) (2) (1) (4) (5)(14)</p>
	<p>US ▶</p>	<p>8502AX428685001</p>	
		<p>R502AS429395001</p>	 <p>(14) (12) (4) (5) (1) (3) (2)</p>
		<p>G502AP428685005</p>	 <p>(12)(3)(2) (1) (4) (5) (14) (12)(3)(2) (1) (4) (5) (14)</p>
	<p>US ▶</p>	<p>8502AP428685005</p>	

numatics
502



High flow
0,7 ... 9 bar



R502ARS12JA0010	RS			
R502ARS12J61Y10		<p>....RS...A00.</p>		
R502ARD12J16P10	RD			
R502ARD12J63L10				
R502ARD12J16N10				
R502ARD12J63M10				
R502ARD12JA0010				
R502ARD12J61Y10	<p>....RD...16P.. RD...16N.. RD...A00..</p>			
R502ARE12J16P10	RE			
R502ARE12J63L10				
R502ARE12J16N10				
R502ARE12J63M10				
R502ARE12JA0010				
R502ARE12J61Y10	<p>....RE...16P.. RE...16N.. RE...A00..</p>			
R502ART12J16P10	RT			
R502ART12J63L10				
R502ART12J16N10				
R502ART12J63M10				
R502ART12JA0010				
R502ART12J61Y10	<p>....RT...16P.. RT...16N.. RT...A00..</p>			

numatics
502



High flow
10 ... 130 psig

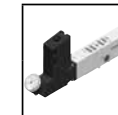

R502ARS11JA0010	RS			
R502ARS11J61Y10		<p>....RS...A00.</p>		
R502ARD11J16P10	RD			
R502ARD11J63L10				
R502ARD11J16N10				
R502ARD11J63M10				
R502ARD11JA0010				
R502ARD11J61Y10	<p>....RD...16P.. RD...16N.. RD...A00..</p>			
R502ARE11J16P10	RE			
R502ARE11J63L10				
R502ARE11J16N10				
R502ARE11J63M10				
R502ARE11JA0010				
R502ARE11J61Y10	<p>....RE...16P.. RE...16N.. RE...A00..</p>			
R502ART11J16P10	RT			
R502ART11J63L10				
R502ART11J16N10				
R502ART11J63M10				
R502ART11JA0010				
R502ART11J61Y10	<p>....RT...16P.. RT...16N.. RT...A00..</p>			

numatics
502



ISO 15407-2
18 mm
0,7 ... 9 bar

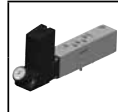

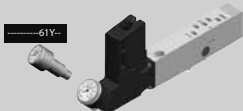
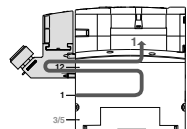
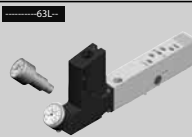
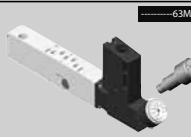
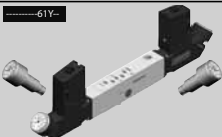
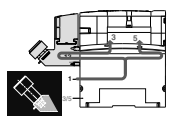
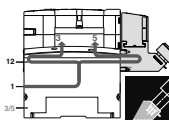
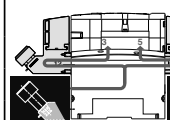
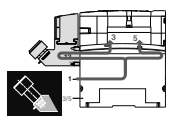
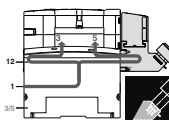
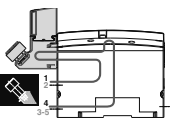
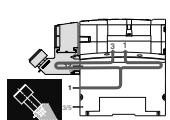
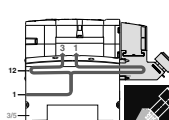
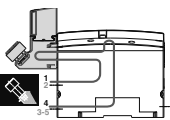
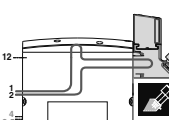
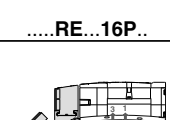
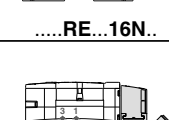
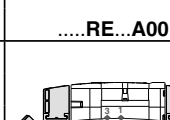
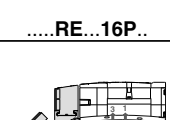
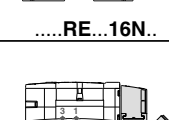



				
R502ARS12JA0020	RS			
R502ARS12J61Y20	RS...A00.		
				
R502ARD12J16P20	RD			
R502ARD12J63L20				
R502ARD12J16N20				
R502ARD12J63M20				
R502ARD12JA0020				
R502ARD12J61Y20RD...16P..			
R502ARE12J16P20	RE			
R502ARE12J63L20				
R502ARE12J16N20				
R502ARE12J63M20				
R502ARE12JA0020				
R502ARE12J61Y20RE...16P..			
R502ART12J16P20	RT			
R502ART12J63L20				
R502ART12J16N20				
R502ART12J63M20				
R502ART12JA0020				
R502ART12J61Y20RT...16P..			
R502ART12J63L20RT...16N..			
R502ART12J16N20RT...A00..			

numatics
502

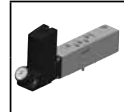

ISO 15407-2
18 mm
10 ... 130 psig

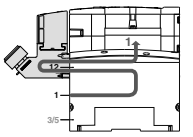
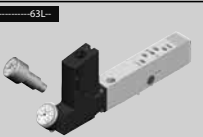

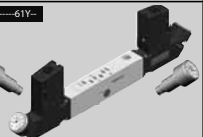
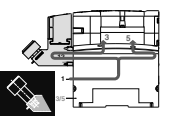
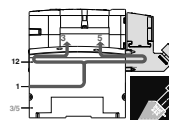
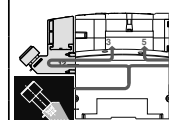
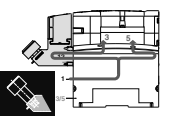
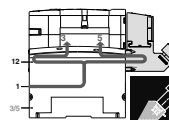
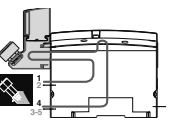
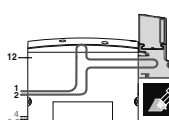
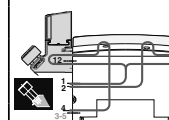
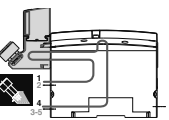
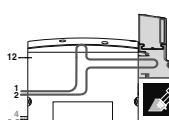
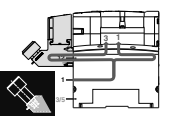
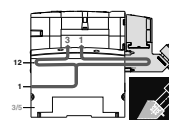
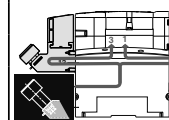
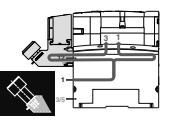
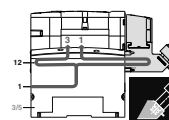
				
R502ARS11JA0020	RS			
R502ARS11J61Y20	RS...A00.		
				
R502ARD11J16P20	RD			
R502ARD11J63L20				
R502ARD11J16N20				
R502ARD11J63M20				
R502ARD11JA0020				
R502ARD11J61Y20RD...16P..			
R502ARE11J16P20	RE			
R502ARE11J63L20				
R502ARE11J16N20				
R502ARE11J63M20				
R502ARE11JA0020				
R502ARE11J61Y20RE...16P..			
R502ART11J16P20	RT			
R502ART11J63L20				
R502ART11J16N20				
R502ART11J63M20				
R502ART11JA0020				
R502ART11J61Y20RT...16P..			
R502ART11J63L20RT...16N..			
R502ART11J16N20RT...A00..			

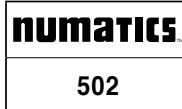

ACCESSORY ZONED POWER (24 VDC Separation)

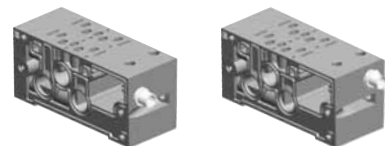

8
G 502AM S M 2 3 V
K K H W A 0 1 2 0

WIRING DIAGRAM

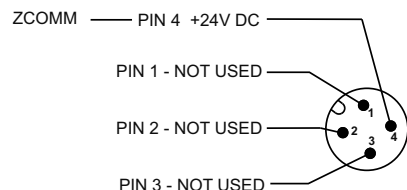

EN	The 0 VDC reference for the +24 VDC applied to Pin 4 of the M12 Connector MUST be the same as the one used on G3 / 580 / Terminal Strip / 25 or 37 Pin Sub-D / 19 or 26 Pin Round Connector. If multiple 24 VDC power supplies are used the 0 VDC references of each power supply MUST be connected together.
FR	La référence 0 VCC pour le +24 VCC appliquée à la broche 4 du connecteur M12 DOIT être la même que celle utilisée avec le G3 / 580 / bornier / connecteur Sub-D 25 ou 37 broches / connecteur rond 19 ou 26 broches. Si des alimentations multiples en 24 VCC sont utilisées les références 0 VCC de chaque alimentation DOIVENT être connectées ensemble.
DE	Die 0-VDC-Referenz für die +24 VDC, die an Pin 4 von Buchse M12 angelegt werden, MÜSSEN mit der übereinstimmen, die an G3 / 580 / Klemmenleiste / 25- oder 37-polige Sub-D- / runde 19- oder 26-polige Buchse verwendet werden. Wenn mehrere 24-VDC-Stromversorgungen verwendet werden, MÜSSEN die 0-VDC-Referenzen aller Stromversorgungen miteinander verbunden werden.
ES	La referencia de 0 VCC para los +24 V CC aplicados a la patilla 4 del conector M12 DEBE ser la misma que la utilizada en el conector redondo de 19 o 26 pines / G3 / 580 / tira de terminales / Sub-D de 25 o 37 pines. Si se utilizan varias fuentes de alimentación de 24 V CC en las referencias de 0 VCC de cada fuente de alimentación, DEBEN conectarse juntas.
IT	Il riferimento 0 V CC per la tensione a +24 V CC, applicata al piedino 4 del connettore M12, DEVE essere lo stesso utilizzato nel caso del G3 / 580 / Morsettera / Sub-D a 25 o 37 piedini / Connettore rotondo a 19 o 26 piedini. Nel caso siano utilizzate alimentazioni multiple a 24 V CC, i riferimenti 0 V CC di ciascuna alimentazione DEVONO essere connessi assieme.
NL	De 0 VDC referentie voor +24 VDC toegepast op pin 4 van de M12-connector MOET identiek zijn aan de referentie die wordt gebruikt op G3 / 580 / Klemmenstrook / 25 of 37 Pin Sub-D / 19 of 26 Pin Round Connector. Indien er meerdere 24 VDC voedingen worden gebruikt MOETEN de 0 VDC referenties van iedere voeding op elkaar zijn aangesloten.
NO	Referansen 0 VDC for +24 VDC bruk på pinne 4 til M12-kontaktene MÅ være det samme som den som brukes på G3 / 580 / terminalstripen / 25 eller 37 pinnars Sub-D / 19 eller 26 pinnars rund kontakt. Hvis flere 24 VDC-strømforsyninger brukes MÅ 0 VDC-referansene til hver strømforsyning kobles sammen.
SE	0 V DC-referens för +24 V DC på stift 4 på M12-kontaktdonet MÅSTE vara samma som den som används på G3/580/anslutningsrad/25- eller 37-stifts sub-D/19- eller 26-stifts runt kontaktad. Om flera 24 V DC-nätenheter används MÅSTE 0 V DC-referenserna för varje nätenhet kopplas ihop.
FI	M12-liittimen tappiin +24 VDC:n 0 VDC -referenssin ON OLTAVA sama, jota käytetään G3 / 580 / liitäntärimä / 25:ssä tai 37 tapin Sub-D / 19:ssä tai 26 tapin pyöreässä liittimessä. Jos käytetään useita 24 VDC:n virtalähteitä, kaikkien virtalähteiden 0 VDC -referenssin ON LIITETTÄVÄ yhteen.
DK	0 VDC-referencen for +24 VDC, der anvendes til Ben 4 for M12-stik, SKAL være den samme som den, der anvendes på G3 / 580 / Terminalens bånd / 25 eller 37 bens Sub-D / 19 eller 26 bens rundt stik. Hvis der anvendes flere 24 VDC-strømforsyninger, SKAL 0 VDC-referencerne for hver strømforsyning være tilsluttet sammen.
PT	A referência 0 VCC para a +24 VCC aplicada ao pino 4 do conector M12 TEM de ser igual à utilizada na G3/580/faixa de terminais/sub-D de 25 ou 37 pínos/conector redondo de 19 ou 26 pínos. Se utilizar várias fontes de alimentação de 24 VCC, TEM de ligar em conjunto as referências 0 VCC de cada fonte de alimentação.
GR	Η τάση αναφοράς των 0 VDC για τα +24 VDC που εφαρμόζεται στον Πίνο 4 του Συνδέσμου M12 ΠΡΕΠΕΙ να είναι ο ίδιος με αυτόν που χρησιμοποιείται σε G3 / 580 / Τερματική ταινία / Sub-D 25 ή 37 πείρων / Στρογγυλό σύνδεσμο 19 ή 26 πείρων. Εάν χρησιμοποιούνται πολλαπλά τροφοδοτικά 24 VDC με τάσεις αναφοράς 0 VDC για κάθε τροφοδοτικό ΠΡΕΠΕΙ να είναι συνδεδεμένα μεταξύ τους.
CZ	Referenční napětí 0 V DC pro napětí +24 V DC na kolků 4 konektoru M12 MUSÍ být stejné jako napětí použité na přístroji G3 / 580 / svorkovnice / kolk 25 nebo 37 konektoru Sub-D / kolk 19 nebo 26 kulatého konektoru. Jestliže se používá několik napájecích zdrojů 24 V DC, MUSÍ být referenční napětí 0 V DC každého napájení připojeno společně.
PL	Odniesienie 0 VDC dla +24 VDC stosowanego dla Pinu 4 złącza M12 MUSI być takie samo jak te zastosowane na Listwie zaciskowej G3 / 580 / Sub-D 25 lub 37 stykowym / Okrągłym złączu 19 lub 26 stykowym. Jeśli zastosowanych jest kilka zasilaczy 24 VDC, wówczas odniesienia 0 VDC każdego zasilacza MUSZA być połączone razem.
HU	Az M 12-es csatlakozó 4. tűjére alkalmazott +24 V DC 0 V DC referenciájának azonosnak KELL lennie a G3 / 580 / sorkapcsolóé / 25- vagy 37-tűs Sub-D / 19- vagy 26-tűs kerek csatlakozó értékével. Amennyiben több 24 V DC értékű tápellátás használ, csatlakoztatni KELL az összes tápellátás 0 V DC referenciáját.
RU	Отсчетное напряжение 0 В пост. тока для +24 В пост. тока, подаваемое на конт. 4 Разъема M12, ДОЛЖНО быть таким же, как напряжение, используемое на G3 / 580 / Клеммная колодка / Разъем Sub-D Конт. 25 или 37 / Круглый разъем Конт. 19 или 26. При использовании нескольких источников питания 24 В пост. тока выводы отсчетного напряжения 0 В пост. тока каждого источника питания ДОЛЖНЫ быть соединены вместе.



ACCESSORY ZONED POWER (24 VDC Separation)

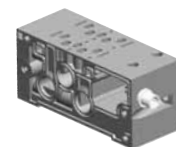
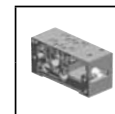

8
G 502AM S M 2 3 V
K K H W A 0 1 2 0



ISO 13849

EN	The Zoned Power manifold could be used as a Safety Related Product of a Control System (SRP/CS) compliant with ISO 13849 safety standards up to Category 3 / PLd. It is not possible to reach Category 4 / PLe as the electrical construction does not allow the required continuous monitoring by external safety relays or safety output devices. Although the Zoned Power manifold can be compatible with Category 3 / PLd of a Safety Related Product of a Control System (SRP/CS), the final safety level must be calculated by the user in accordance with ISO 13849 standards, integrating the data of the complete system (e.g. architecture, inputs, logic, outputs and monitoring). Reliability data of our pneumatic components can be given upon request.
FR	Les lots pneumatiques Zoned Power peuvent être utilisés comme partie d'un système de commande relative à la sécurité (SRP/CS) conforme aux normes ISO 13849 jusqu'à la Catégorie 3 / PLd. Il n'est pas possible d'atteindre la catégorie 4 / PLe car la construction électrique ne permet pas la réalisation, par les relais de sécurité ou les systèmes de sortie de sécurité externes, du diagnostic continu exigé. Bien que les lots pneumatiques Zoned Power puissent être utilisés comme partie d'un système de commande relative à la sécurité (SRP/CS) de catégorie 3 / PLd, le niveau de sécurité final doit être calculé par l'utilisateur en accord avec les normes ISO 13849, intégrant les données de l'ensemble du système (architecture, entrées, logique, sorties et diagnostic). Les données de fiabilité de nos composants pneumatiques peuvent être fournies sur demande.
DE	Die Zoned Power-Ventilinsel könnte als sicherheitsrelevantes Produkt eines Steuersystems (SRP/CS) verwendet werden, das den ISO 13849-Sicherheitsnormen bis Kategorie 3/PLd entspricht. Es ist nicht möglich, Kategorie 4/PLe zu erreichen, da die elektrische Konstruktion die erforderliche fortlaufende Überwachung durch externe Sicherheitsrelais oder Sicherheitsausgabegeräte nicht ermöglicht. Auch wenn die Zoned Power-Ventilinsel mit Kategorie 3/PLd eines sicherheitsrelevanten Produkts eines Steuersystems (SRP/CS) kompatibel sein kann, muss die endgültige Sicherheitsstufe vom Benutzer in Übereinstimmung mit ISO 13849-Normen unter Einbeziehung der Daten des vollständigen Systems (z. B. Architektur, Eingänge, Logik, Ausgänge und Überwachung) berechnet werden. Die Zuverlässigkeitsdaten unserer pneumatischen Komponenten können auf Anfrage bereitgestellt werden.
ES	El colector Zoned Power podría utilizarse como un producto relacionado con la seguridad de un sistema de control (SRP/CS) conforme con las normas de seguridad ISO 13849 hasta la Categoría 3 / PLd. No es posible alcanzar la Categoría 4 / PLe puesto que la construcción eléctrica no permite el control continuo requerido mediante relés de seguridad externos o dispositivos de salida de seguridad. Aunque el colector Zoned Power puede ser compatible con la Categoría 3 / PLd de un producto relacionado con la seguridad de un sistema de control (SRP/CS), el nivel de seguridad final debe calcularse de acuerdo con las normas ISO 13849, integrando los datos del sistema completo (por ejemplo, arquitectura, entradas, lógica, salidas y control). Podemos facilitar los datos de fiabilidad de nuestros componentes neumáticos previa petición.
IT	Il collettore - ad alimentazione secondo la zona - Zoned Power può essere impiegato come 'prodotto correlato alla sicurezza' di un sistema di comando (SRP/CS), conforme alle norme di sicurezza ISO 13849 fino alla Categoria 3 / PLd. Non è possibile ottenere la Categoria 4 / PLe, dato che la costruzione elettrica non consente il monitoraggio continuo richiesto dal relé esterni di sicurezza. Sebbene il collettore Zoned Power possa essere compatibile con la Categoria 3 / PLd di un 'prodotto correlato alla sicurezza' di un sistema di comando (SRP/CS), il livello finale di sicurezza potrà essere calcolato dall'utente in conformità alle norme ISO 13849, integrando i dati del sistema completo (ad esempio l'architettura, gli input, la logica, gli output ed il monitoraggio). I dati di affidabilità dei nostri componenti pneumatici possono essere comunicati su richiesta.
NL	Het Zoned Power verdeelstuk kan worden gebruikt als veiligheidsproduct voor een besturingssysteem (SRP/CS) in overeenstemming met ISO 13849 veiligheidsnormen tot en met categorie 3 / PLd. Categorie 4 / PLe is niet haalbaar, aangezien de elektrische constructie de vereiste continue bewaking door externe veiligheidsrelais of uitvoerapparaten niet toelaat. Hoewel het Zoned Power verdeelstuk compatibel kan zijn met categorie 3 / PLd van een veiligheidsproduct voor een besturingssysteem (SRP/CS), dient het uiteindelijke veiligheidsniveau door de gebruiker te worden berekend in overeenstemming met ISO 13849 normen, waarbij de gegevens van het hele systeem worden verwerkt (v. architectuur, ingangen, logica, uitgangen en bewaking). De gegevens omtrent betrouwbaarheid van onze pneumatische componenten worden op verzoek verstrekt.
NO	Den sonede strøm manifold kan brukes som et sikkerhetsrelatert produkt i et kontrollsystem (SRP/CS) i samsvar med ISO 13849 sikkerhetsstandarder opp til kategori 3 / PLd. Det er ikke mulig å nå kategori 4 / PLe fordi den elektriske oppbygningen ikke tillater den nødvendige, kontinuerlige overvåkingen av eksterne sikkerhetsrelé eller sikkerhetsutgangsenheter. Selv om den sonede strøm manifold kan være forenelig med kategori 3 / PLd til et sikkerhetsrelatert produkt i et kontrollsystem (SRP/CS), må det endelige sikkerhetsnivået beregnes av brukeren i samsvar med ISO 13849-standarder, integrering av data i det komplette systemet (f.eks. arkitektur, inngang, logikk, utgang og overvåking). Pålitelighetsdata for våre pneumatiske komponenter leveres etter anmodning.
SE	Zoned Power-grenkopplingen kan användas som en säkerhetsrelaterad produkt i ett styrsystem (SRP/CS) som överensstämmer med säkerhetsstandarderna ISO 13849 upp till kategori 3/PLd. Det är inte möjligt att nå kategori 4/PLe eftersom den elektriska konstruktionen inte medger den kontinuerliga övervakning som krävs av externa säkerhetsreläer eller säkerhetsutgångsenheter. Även om Zoned Power-grenkopplingen kan vara kompatibel med kategori 3/PLd hos en säkerhetsrelaterad produkt i ett styrsystem (SRP/CS) måste den slutliga säkerhetsnivån beräknas av användare enligt standarderna ISO 13849 och data gällande hela systemet integreras (t.ex. arkitektur, inngångar, logik, utgångar och övervakning). Tillförlighetsdata för våra pneumatiska komponenter kan fås på begäran.

numatics

502

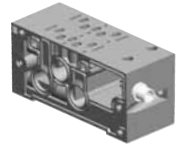
**ACCESSORY
ZONED POWER (24 VDC Separation)**8
G 502AM^S 2²
K M 2³HW^VA00 1² 0
K

ISO 13849

FI	Zoned Power -kokoojaa voitaisiin käyttää ohjausjärjestelmän (SRP/CS) turvallisuuteen liittyvänä tuotteena, joka noudattaa ISO 13849 -turvastandardeja kategoriinaan 3 / PLd saakka. Kategoriinaan 4 / PLe se ei ole riittävä, koska sähköinen rakenne ei mahdollista vaadittua ulkopuolisten turvareiden tai turvallisuuden tulostuslaitteiden jatkuvaa seurantaa. Vaikka Zoned Power -kokoojaa voikin olla ohjausjärjestelmässä (SRP/CS) kategorian 3 / PLd -mukainen turvallisuuteen liittyvä tuote, on käyttäjän arvioitava lopullinen turvataso ISO 13849 -standardien mukaan ottaen huomioon kokonaisuuden tiedot (esim. rakenne, tulot, logiikka, lähdöt ja seuranta). Pyydettyäsi voimme antaa pneumaattikkomponenttiemme luotettavuustiedot.
DK	Zoned Power-manifolden kan anvendes som et SRP/CS-system (Safety Related Product of a Control System) overensstemmende med ISO 13849-sikkerhedsstandarderne op til kategori 3/PLd. Det er ikke muligt at opnå kategori 4/PLe, da den elektriske konstruktion ikke tillader den påkrævede løbende overvågning af eksterne sikkerhedsrelæer eller sikkerhedsenheder. Selv om Zoned Power-manifolden kan være kompatibel med kategori 3/PLd for et SRP/CS-system (Safety Related Product of a Control System), skal det endelige sikkerhedsniveau beregnes af brugeren i overensstemmelse med ISO 13849-standarderne og skal integrere data for hele systemet (dvs. arkitektur, input, logik, output og overvågning). Pålidelige data for vores pneumatiske komponenter kan oplyses på anmodning.
PT	Pode utilizar o coletor de Potência Dividida em Zonas como um Produto Relacionado com a Segurança de um Sistema de Controlo (SRP/CS) compatível com as normas de segurança ISO 13849 até à Categoria 3/PLd. Não é possível alcançar a Categoria 4/PLe, porque a construção elétrica não permite a monitorização contínua obrigatória com relés de segurança externos ou dispositivos de saída de segurança. Apesar de o coletor de Potência Dividida em Zonas poder ser compatível com a Categoria 3/PLd de um Produto Relacionado com a Segurança de um Sistema de Controlo (SRP/CS), o utilizador tem de calcular o nível de segurança final de acordo com as normas ISO 13849, integrando os dados de todo o sistema (ex. arquitetura, entradas, lógica, saídas e monitorização). Os dados de fiabilidade dos componentes pneumáticos podem ser fornecidos a pedido.
GR	Η πολλαπλή Zoned Power θα μπορούσε να χρησιμοποιηθεί ως Προϊόν Ασφαλείας Συστήματος Ελέγχου (SRP/CS) σε συμμόρφωση με τα πρότυπα ασφαλείας του ISO 13849 έως την Κατηγορία 3 / PLd. Η επίτευξη της Κατηγορίας 4 / PLe δεν είναι εφικτή καθώς η δομή του ηλεκτρικού συστήματος δεν επιτρέπει την απαιτούμενη συνεχή παρακολούθηση από εξωτερικά relé ασφαλείας ή διατάξεις εξόδου ασφαλείας. Παρόλο που η πολλαπλή Zoned Power μπορεί να είναι συμβατή με την Κατηγορία 3 / PLd ενός Προϊόντος Ασφαλείας Συστήματος Ελέγχου (SRP/CS), το τελικό επίπεδο ασφαλείας πρέπει να υπολογίζεται από τον χρήστη σύμφωνα με τα πρότυπα ISO 13849, ενσωματώνοντας τα δεδομένα ολοκλήρου του συστήματος (π.χ. αρχιτεκτονική, εισόδους, λογικά στοιχεία, εξόδους και παρακολούθηση). Τα δεδομένα αξιοπιστίας των pneυματικών εξαρτημάτων μας διατίθενται, αν ζητηθούν.
CZ	Potrubi Zoned Power lze použít jako produkt řídicího systému související s bezpečností (Safety Related Product of a Control System, SRP / CS) kompatibilní s bezpečnostními normami ISO 13849 až do kategorie 3 / PLd. Kategorie 4 / PLe nelze dosáhnout, protože elektrická konstrukce požadované kontinuální sledování externími bezpečnostními relé nebo bezpečnostními výstupními zařízeními. Ačkoli potrubi Zoned Power může být kompatibilní s kategorií 3 produktu řídicího systému souvisejícího s bezpečností (Safety Related Product of a Control System, SRP / CS), konečnou úroveň bezpečnosti musí vypočítat uživatel v souladu s normami ISO 13849, integrující data celého systému (např. architektura, vstupy, logika, výstupy a monitorování). Údaje o spolehlivosti našich pneumatických součástí poskytneme na vyžádání.
PL	Rura rozgaleźna mocy strefowej mo¿e być stosowana jako produkt systemu sterowania (SRP/CS) związany z bezpieczeñstwem, zgodny z normami bezpieczeñstwa ISO 13849 do maks. kategorii 3 / PLd. Nie jest mo¿liwe osiagniecie kategorii 4 / PLe, poniewa¿ budowa układu elektrycznego nie umo¿liwia wymaganego ciaglego monitorowania przez zewnętrzne przekazniki bezpieczeñstwa lub zabezpieczajace urzadzenia wyjsciove. Chocia¿ rura rozgaleźna mocy strefowej mo¿e być zgodna z kategorią 3 / PLd produktu zwiazanego z bezpieczeñstwem systemu sterowania (SRP/CS), koñcowy poziom bezpieczeñstwa musi być obliczony przez u¿ytkownika zgodnie z normami ISO 13849, z uwzględnieniem danych całego systemu (np. architektury, wejść, logiki, wyjść i monitorowania). Dane dotyczace niezawodności naszych podzespolow pneumatycznych mo¿na uzyskac na zamówienie.
HU	A Zoned Power elosztó a Vezérlő rendszer (SRP/CS) Biztonsági termékéként is használható, megfelel az ISO 13849 biztonsági szabványnak a 3 / PLd kategóriájáig. Nem lehet elérni vele a 4 / PLe kategóriát, mivel az elektromos szerkezet nem teszi lehetővé a kívánt folyamatos megfigyelést a külső biztonsági relé vagy biztonsági kimeneti eszközök segítségével. Azonban a Zoned Power elosztó kompatibilis lehet a Vezérlő rendszer (SRP/CS) Biztonsági termékének a 3 / PLD kategóriájával. A végleges biztonsági szintet a felhasználónak az ISO 13849 szabvány alapján kell kalkulálnia a teljes rendszer adatait összegezve (pl.: építéset, bemenetek, logika, kimenetek és megfigyelés). A pneumatikus alkatrészeink megbízhatósági adatai kérésre megadhatóak.
RU	Распределительная коробка питания может использоваться в качестве безопасной детали для системы управления (SRP/CS) в соответствии со стандартами безопасности ISO 13849 относительно категории 3 / уровня производительности d. Невозможно достичь категории 4 / уровня производительности e, поскольку электрической конструкцией не предусмотрен непрерывный контроль внешних предохранительных реле или защитных выходных устройств. Хотя распределительная коробка питания совместима с категорией 3 / уровнем производительности d, что обеспечивает безопасность детали для системы управления (SRP/CS), пользователь должен рассчитать конечный уровень безопасности согласно стандартам ISO 13849 с учетом данных целой системы (например: архитектура, входы, логика, выходы и мониторинг). Данные о надежности пневматических компонентов предоставляются по запросу.

numatics

CE

**ACCESSORY
MID STATION SUPPLY AND EXHAUST
503 double Z-board, 15407-2 double Z-board and
15407-1 no Zboard**

502

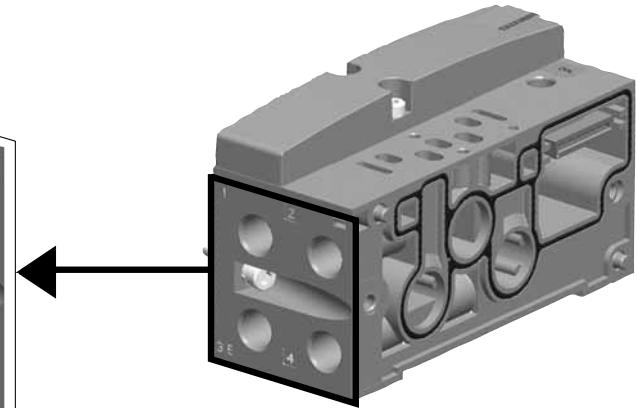
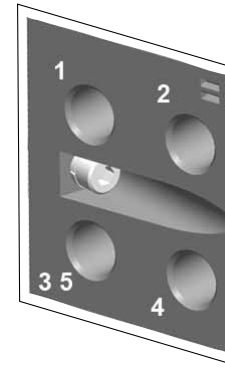
8
G 502AZ^M 2²
K V 2³MA^VA00 1² 0
3