



**EMERSON**<sup>TM</sup>



# 2000X Micro Actuator

# Operating Manual

**Branson Ultrasonics Corp.**  
120 Park Ridge Road  
Brookfield, CT 06804  
(203) 796-0400  
<http://www.bransonultrasonics.com>

**BRANSON**

## Manual Change Information

At Branson, we strive to maintain our position as the leader in ultrasonics plastics joining, metal welding, cleaning, and related technologies by continually improving our circuits and components in our equipment.

These improvements are incorporated as soon as they are developed and thoroughly tested. Information concerning any improvements will be added to the appropriate technical documentation at its next revision and printing. Therefore, when requesting service assistance for specific units, note the Revision information found on this document, and refer to the printing date which appears in this page.

## Copyright and Trademark Notice

Copyright © 2023 Branson Ultrasonics Corporation. All rights reserved. Contents of this publication may not be reproduced in any form without the written permission of Branson Ultrasonics Corporation.

Loctite is a registered trademark of Loctite Corporation.

Mylar is a registered trademark of DuPont Teijin Films.

Other trademarks and service marks mentioned herein are held by their respective owners.

## Foreword

Congratulations on your choice of a Branson Ultrasonics Corporation system!

The Branson 2000X Series system is process equipment for the joining of plastic parts using ultrasonic energy. It is the newest generation of product using this sophisticated technology for a variety of customer applications. This Operating Manual is part of the documentation set for this system, and should be kept with the equipment.

Thank you for choosing Branson!

## Introduction

This manual is arranged into several structured chapters which will help you find the information you may need to know to safely handle, install, set up, program, operate, and/or maintain this product. Please refer to the [Table of Contents](#) and/or the [Index](#) of this manual to find the information you may be looking for. In the event you require additional assistance or information, please contact our Product Support department (see [1.4 How to Contact Branson](#) for information on how to contact them) or your local Branson representative.



---

# Table of Contents

---

**Chapter 1: Safety and Support**

1.1	Safety Requirements and Warnings . . . . .	2
1.2	General Precautions . . . . .	5
1.3	Warranty Statement Disclaimer . . . . .	8
1.4	How to Contact Branson . . . . .	10
1.5	Returning Equipment for Repair . . . . .	11
1.6	Obtaining Replacement Parts . . . . .	14

**Chapter 2: Introduction**

2.1	Models Covered . . . . .	16
2.2	Overview of this Model . . . . .	19
2.3	Features of the System . . . . .	20
2.4	Controls and Indicators . . . . .	22
2.5	Welding Systems . . . . .	23
2.6	Glossary of Terms . . . . .	25

**Chapter 3: Delivery and Handling**

3.1	Shipping and Handling . . . . .	32
3.2	Receiving . . . . .	33
3.3	Unpacking the Actuator and Interface Box . . . . .	34
3.4	Returning Equipment . . . . .	35

**Chapter 4: Technical Specifications**

4.1	Technical Specifications . . . . .	38
4.2	Physical Description . . . . .	39

**Chapter 5: Installation and Setup**

5.1	About Installation . . . . .	42
5.2	Handling and Unpacking . . . . .	43
5.3	Take Inventory of Small Parts . . . . .	45
5.4	Installation Requirements . . . . .	46
5.5	Installation Steps . . . . .	52
5.6	Safety Equipment . . . . .	60
5.7	Assembly the Acoustic Stack . . . . .	61
5.8	Testing the Installation . . . . .	65
5.9	Still Need Help? . . . . .	66

**Chapter 6: Operation**

6.1	Actuator Controls . . . . .	68
6.2	Initial Actuator Settings . . . . .	69
6.3	Operating the Actuator . . . . .	74

**Chapter 7: Maintenance**

7.1	Calibration . . . . .	76
7.2	Periodic and Preventive Maintenance . . . . .	77
7.3	Parts Lists . . . . .	81



---

# List of Figures

---

## Chapter 1: Safety and Support

Figure 1.1	Connector label located on the back of the 2000X Micro Actuator Interface Box . . . . .	3
Figure 1.2	Caution label found on the front of the 2000X Micro Actuator . . . . .	3
Figure 1.3	Caution label found on the front of the 2000X Micro Actuator . . . . .	3
Figure 1.4	Warning labels found on the back of the 2000X Micro Actuator . . . . .	4
Figure 1.5	Warning label found inside the 2000X Micro Actuator . . . . .	4

## Chapter 2: Introduction

Figure 2.1	Frontal view of the 2000X Micro Actuator Power Supply Manual Set. . . . .	17
------------	---	----

## Chapter 3: Delivery and Handling

## Chapter 4: Technical Specifications

Figure 4.1	2000X Micro Actuator Pneumatic System . . . . .	40
------------	---	----

## Chapter 5: Installation and Setup

Figure 5.1	Ultrasonic Converter (J-Type for Stand Alone Use) and Booster . . . . .	44
Figure 5.2	Power Supply Dimensional Drawing . . . . .	47
Figure 5.3	2000X Micro Actuator and Interface Box Dimensional Drawing . . . . .	48
Figure 5.4	Block Wiring Diagram. . . . .	49
Figure 5.5	Rear view of Actuator, showing Mounting Surface, Bolt and Guide Pin locations . . . . .	53
Figure 5.6	Interface Box Mounting Plate (optional) . . . . .	54
Figure 5.7	Mechanical Stop Installations and Adjustment. . . . .	55
Figure 5.8	Connections on Rear of Power Supply . . . . .	56
Figure 5.9	Electrical Connections from Power Supply to a 2000X Micro Actuator and Interface Box . . . . .	57
Figure 5.10	Start Switch Connection Codes . . . . .	58
Figure 5.11	Line Cord Color Code . . . . .	59
Figure 5.12	Assembling the 40 kHz Acoustic Stack . . . . .	62
Figure 5.13	Connecting Tip to Horn. . . . .	63
Figure 5.14	Installing the 40 kHz Stack in the 2000X Micro Actuator. . . . .	64
Figure 5.15	Normal Front Panel Display After Power-Up . . . . .	65

## Chapter 6: Operation

Figure 6.1	Mechanical Stop Installation and Adjustment . . . . .	73
------------	---	----

## Chapter 7: Maintenance





---

# List of Tables

---

## Chapter 1: Safety and Support

Table 1.1	Hearing Protectors . . . . .	6
Table 1.2	Sound Absorbing Materials . . . . .	6
Table 1.3	Static Protection Equipment . . . . .	6
Table 1.4	Warranty Period . . . . .	8
Table 1.5	Branson Contacts . . . . .	13

## Chapter 2: Introduction

Table 2.1	Frontal View of the 2000X Micro Actuator and Interface Box . . . . .	17
Table 2.2	Glossary of Terms . . . . .	25

## Chapter 3: Delivery and Handling

Table 3.1	Environmental Specifications . . . . .	32
Table 3.2	Receiving . . . . .	33

## Chapter 4: Technical Specifications

Table 4.1	Environmental Specifications . . . . .	38
Table 4.2	2000X Micro Actuator Performance Specifications . . . . .	38

## Chapter 5: Installation and Setup

Table 5.1	Ultrasonic Converter . . . . .	44
Table 5.2	Power Supply and/or Actuator Assemblies . . . . .	45
Table 5.3	List of Cables . . . . .	45
Table 5.4	Environmental Specifications . . . . .	46
Table 5.5	Input Power requirements . . . . .	49
Table 5.6	Air Cylinder Consumption . . . . .	50
Table 5.7	Tools . . . . .	61
Table 5.8	Assembling the 40 kHz Acoustic Stack . . . . .	61
Table 5.9	Stud Torque Values . . . . .	62
Table 5.10	Tip to Horn Torque Specifications . . . . .	63

## Chapter 6: Operation

Table 6.1	To adjust the Mechanical Stop. . . . .	72
Table 6.2	To Operate the 2000X Micro Actuator . . . . .	74

## Chapter 7: Maintenance

Table 7.1	Component Replacements Based on Cycles Run . . . . .	80
Table 7.2	Accessories List for 2000X Micro Actuator . . . . .	81
Table 7.3	Spare Parts List for the 2000X Micro Actuator . . . . .	81
Table 7.4	Suggested Spares . . . . .	83



---

# Chapter 1: Safety and Support



---

<b>1.1</b>	<b>Safety Requirements and Warnings . . . . .</b>	<b>2</b>
<b>1.2</b>	<b>General Precautions . . . . .</b>	<b>5</b>
<b>1.3</b>	<b>Warranty Statement Disclaimer . . . . .</b>	<b>8</b>
<b>1.4</b>	<b>How to Contact Branson . . . . .</b>	<b>10</b>
<b>1.5</b>	<b>Returning Equipment for Repair . . . . .</b>	<b>11</b>
<b>1.6</b>	<b>Obtaining Replacement Parts . . . . .</b>	<b>14</b>

## 1.1 Safety Requirements and Warnings

### 1.1.1 Symbols Found in this Manual

These symbols used throughout this manual warrant special attention:

<b>WARNING</b>	<b>Indicates a possible danger</b>
	If these risks are not avoided, death or severe injury might result.
<b>CAUTION</b>	<b>Indicates a possible danger</b>
	If these risks are not avoided, slight or minor injury might result.
<b>NOTICE</b>	<b>Indicates a possible damaging situation</b>
	If this situation is not avoided, the system or something in its vicinity might get damaged. Application types and other important or useful information are emphasized.

## 1.1.2 Symbols Found on the Product

Familiar graphic warning symbols are used to alert the user to items of concern or hazard. The following warning symbols appear on the 2000X Micro Actuator and on the 2000X Micro Actuator Interface Box:

**Figure 1.1** Connector label located on the back of the 2000X Micro Actuator Interface Box

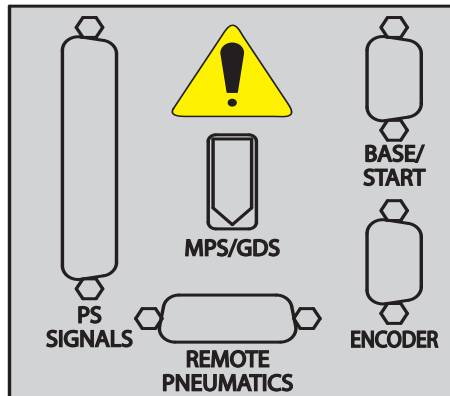

**Figure 1.2** Caution label found on the front of the 2000X Micro Actuator



**Figure 1.3** Caution label found on the front of the 2000X Micro Actuator

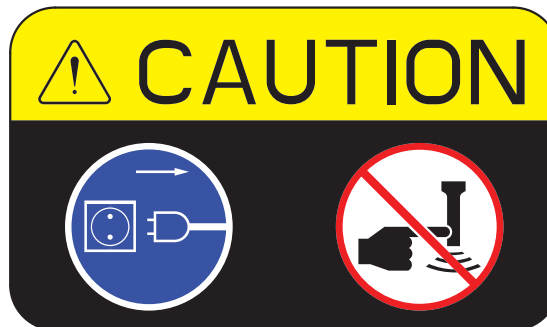

**Figure 1.4** Warning labels found on the back of the 2000X Micro Actuator

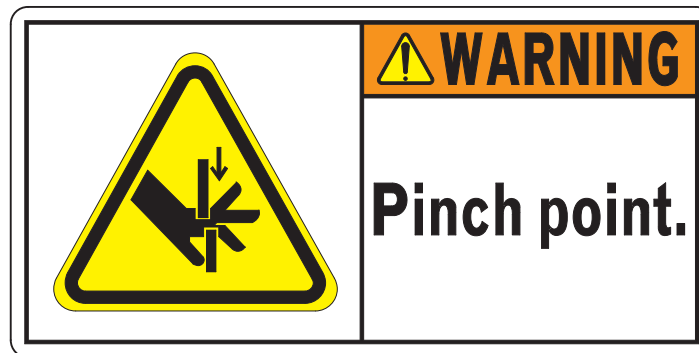
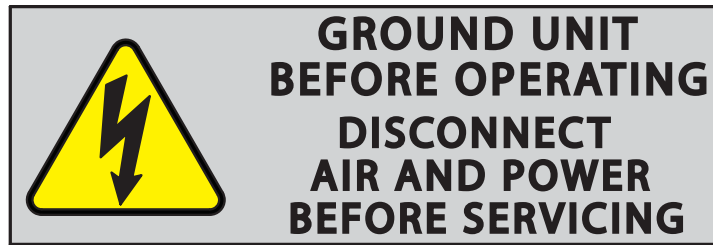

**Figure 1.5** Warning label found inside the 2000X Micro Actuator



## 1.2 General Precautions

Take the following precautions before servicing the power supply:

- Be sure the power switch is in the Off position before making any electrical connections
- To prevent the possibility of an electrical shock, always plug the power supply into a grounded power source
- Power supplies produce high voltage. Before working on the power supply module, do the following:
  - Turn off the power supply
  - Unplug main power
  - Allow at least 2 minutes for capacitors to discharge
- High voltage is present in the power supply. Do not operate with the cover removed
- High line voltages exist in the ultrasonic power supply module. Common points are tied to circuit reference, not chassis ground. Therefore, use only non-grounded, battery-powered multimeters when testing these modules. Using other types of test equipment can present a shock hazard.
- Be sure power is disconnected from the power supply before setting a DIP switch
- Keep hands from under the horn. Down force (pressure) and ultrasonic vibrations can cause injury
- Do not cycle the welding system if either the RF cable or converter is disconnected
- When using larger horns, avoid situations where fingers could be pinched between the horn and the fixture
- Be aware that the actuator is "armed" if air pressure is indicated by the pressure indicator on the actuator front panel and/or the air pressure gauge in the remote box
- In normal operation, bearing seals will retain an adequate amount of grease for safe bearing operation. Bearing can leak but contains enough grease for the life of the bearing. Removing and running without grease will void the warranty. For more information contact product support

NOTICE	
	<p>Sound level and frequency of the noise emitted during the ultrasonic assembly process may depend upon a. Type of application, b. Size, shape and composition of the material being assembled, c. Shape and material of the folding fixture, d. Welder setup parameters and e. Tool design. Some parts vibrate at an audible frequency during the process. Some or all of these factors may result in an uncomfortable noise being emitted during the process. In such cases operators may need to be provided with personal protective equipment. See 29 CFR (Code of Federal Regulations) 1910.95 Occupational Noise Exposure. Also see <a href="#">Table 1.1 Hearing Protectors</a>.</p>

## 1.2.1 Manufacturers of Protective Materials and Equipment

**Table 1.1** Hearing Protectors

Hearing Protectors	
<p><b>Safeware, Inc</b> 9475 Lottsford Rd. Suite 150 Largo, MD 20774-5351 <a href="http://www.safewareinc.com">www.safewareinc.com</a></p>	<p><b>David Clark</b> 360 Franklin St. Box 15054 Worcester, MA 01615-0054 <a href="http://www.davidclark.com">www.davidclark.com</a></p>
<p><b>Softcomm Products</b> 2310 - T South Airport Blvd. Chandler, AZ 85224</p>	<p><b>Elvex Corp</b> 13 Trowbridge Drive Bethel, CT 06801</p>

**Table 1.2** Sound Absorbing Materials

Sound Absorbing Material	
<p><b>American Acoustical Products</b> 6 October Hill Road Holliston, MA 01746</p>	<p><b>Tamer Industries</b> 185 Riverside Av. Somerset, MA 02725</p>
<p><b>Singer Safety Co.</b> 2300 W. Logan Blvd. Chicago, IL 60647-2023</p>	<p><b>Foamex</b> 1501 E. Second St. Eddystone, PA 19022</p>
<p><b>Polymer Technologies, Inc.</b> 420 - T Corporate Blvd. Newark, DE 19702</p>	<p><b>Soundcoat Company</b> 1 Burt Drive Deer Park, NY 11729</p>

**Table 1.3** Static Protection Equipment

Static Protection Equipment	
<p><b>Polygenex</b> PO Box 4468 Cary, NC 27519</p>	<p><b>Electrostatics, Inc.</b> 352D Godshall Dr. Harleysville, PA 19438-2017</p>
<p><b>Terra Universal</b> 700 - N Harbor Blvd. Anaheim, CA 92805 <a href="http://www.terrauni.com">www.terrauni.com</a></p>	



### 1.2.2 Intended Use of the System

The 2000X-series Power Supply and 2000X Micro Actuator are components of an ultrasonic welding system. These are designed for a wide variety of welding or processing applications.

### 1.2.3 Safety Measures and Guards

The 2000X Micro Actuator, along with its 2000X distance Power Supply, contains software-controlled electronic safety devices intended to prevent the machine from operating in a fashion harmful to the user. Start Switch and Emergency Stop controls are designed to prevent undesirable startup.

### 1.2.4 Emissions

When being processed, certain plastic material can emit toxic fumes, gases or other emissions that can be hazardous to the operator's health. Where such materials are processed, proper ventilation of the workstation is required. Check your materials suppliers for recommended protection when processing their materials.

CAUTION	General Warning
	<p>Processing of many materials, such as PVC, can be hazardous to an operator's health and could cause corrosion/damage to the equipment. Use proper ventilation and take protective measures.</p>

### 1.2.5 Setting up the Workplace

Measures for setting up a workplace for safe operation of the ultrasonic welder are outlined in [Chapter 1: Safety and Support](#) and in the 2000-series Installation guide.

### 1.2.6 Regulatory Compliance

This product meets electrical safety requirements and EMC (Electromagnetic Compliance) requirements for North America and the European Union.

## 1.3 Warranty Statement Disclaimer

The following excerpts from the “Terms and conditions of Sale” (found on the back of your Invoice) are essential guidelines for the product Warranty issued with your Branson ultrasonic welding components. The items listed in this section specifically address issues involving the delivery, shipment, and warranty period provided. If you have any questions, please refer to the back of the Invoice included with your system, which lists all of the Terms and conditions of Sale, or contact your Branson representative.

### TERMS AND CONDITIONS OF SALE

Branson Ultrasonics Corporation is herein referred to as the “Seller” and the customer or person or entity purchasing products (“Products”) from Seller is referred to as the “Buyer”. Buyer’s acceptance of the Products will manifest Buyer’s assent to these Terms and Conditions.

### ULTRASONIC JOINING EQUIPMENT NORTH AMERICAN WARRANTY POLICY

Each product manufactured by Branson is guaranteed to be free from *defects in material and workmanship* for a period of time specified in [Table 1.4 Warranty Period](#) from the date of the invoice.

**Table 1.4** Warranty Period

Product	Period
Power Supplies	36 months
Actuators	36 months
Actuator, Special	12 months
Integrated Welders	36 months
Accessories	36 months
Converters	36 months (limited to <i>one-time</i> replacement)
Non-Branson equipment (i. e. printers, terminals)	Warranted by the manufacturer
Horns	12 months
Boosters	36 months
Rental Equipment	Same as purchased equipment
Specials and products with EDP prefix 159-XXX-XXX	12 months
Specials and products with EDP prefix 125-XXX-XXX	12 months

## The warranty does *not* apply to:

- Any product which has been subject to misuse, misapplication, neglect (including without limitation inadequate maintenance), accident or improper installation, modification or adjustment
- Applications requiring metal-to-metal contact when the ultrasonic exposure time exceeds 1.5 seconds
- Any product exposed to adverse environments, improper repair or repairs using non-Branson methods or material
- Non-Branson equipment (i.e., horns, boosters, converters) or improperly tuned horns
- Set up/installation of equipment and software updates

## Warranty Service covers the following:

### Repair service at Branson's main repair facility or a regional office:

- Includes parts and labor performed at Branson authorized repair facilities. The customer must return the equipment properly packed with all shipping charges prepaid

### Repair service at the customer site:

- Includes parts and labor at the customer site performed by a Branson technician. The customer is responsible for all travel-related charges

### Module trade-in:

- Includes serialized components for work performed by the customer. The customer orders the replacement components from the Parts Store and issues a P.O. When the failed components are returned to Branson the warranty status is verified and a credit is issued. The customer is responsible for all shipping charges

## Additional Warranty Notes

- Components replaced during in-warranty repair carries the remainder of the original warranty
- Serialized assemblies replaced during the repair of out-of-warranty equipment are warranted for a period of 12 months
- Travel charges for Branson service personnel will be waived on service calls performed within 30 days of invoice date
- Non-serialized parts replaced during the repair of out-of-warranty equipment are warranted for 3 months
- Trade in allowance: Branson out-of-warranty serialized components are entitled to a 25% trade in allowance regardless of age or condition, however, converters must be less than 5 years old to qualify for the trade in

If you have any questions concerning the warranty coverage (including coverage outside of North America), please contact your Branson representative or Branson Customer Support.

## 1.4 How to Contact Branson

Branson is here to help you. We appreciate your business and are interested in helping you successfully use our products. To contact Branson for help, use the following telephone numbers, or contact the field office nearest you.

- Brookfield Main Number (all Departments): (203) 796-0400 (Eastern Time Zone)
- Parts Store: Direct Number for Parts Store: (877) 330-0406 (Central Time Zone)
- Repair department: (877)-330-0405 (Central Time Zone)
- For emergency after-hours service (5pm-8am Est) call (203) 796-0500 (US phone numbers only)

Tell the operator which product you have and which person or department you need (see [1.5.3 Departments to Contact](#)). If you are calling after hours, please leave a voice message with your name and return telephone number.

### 1.4.1 Before Calling Branson for Assistance

This manual provides information for troubleshooting and resolving problems that could occur with the equipment (see [Chapter 7: Maintenance](#)). If you still require assistance, Branson Product Support is here to help you. To help identify the problem, use the following questionnaire which lists the common questions you will be asked when you contact the Product Support department.

**Before calling, determine the following information:**

1. Your company name and location
2. Your return telephone number
3. Have your manual with you. If troubleshooting a problem, refer to [Chapter 7: Maintenance](#)
4. Know your equipment model and serial numbers (found on a gray data label on the units). Information about the Horn (part number, gain, etc.) or other tooling may be etched into the tooling. Software- or firmware-based systems may provide a BOS or software version number, which may be required
5. What tooling (horn) and booster are being used?
6. What are the setup parameters and mode?
7. Is your equipment in an automated system? If so, what is supplying the “start” signal?
8. Describe the problem; provide as much detail as possible. For example, is the problem intermittent? How often does it occur? How long before it occurs if you are just powering up? If an error is occurring, which error (give error number or name)?
9. List the steps you have already taken
10. What is your application, including the materials being processed?
11. Have a list of service or spare parts you have on hand (tips, horns, etc.)
12. Notes: \_\_\_\_\_  
\_\_\_\_\_

## 1.5 Returning Equipment for Repair

Before sending equipment for repair, provide as much information with the equipment to help determine the problem with the system. Fill in any details below or on a separate sheet.

NOTICE	
	<p>To return equipment to Branson, you must first obtain an <b>RGA number</b> from a Branson representative, or the shipment may be delayed or refused.</p>

If you are returning equipment to Branson for repair, you must first call the Repair department to obtain a Returned Goods Authorization (**RGA**) number. (If you request it, the repair department will fax a Returned Goods Authorization form to fill out and return with your equipment).

Branson Repair Department, C/O Zuniga Logistics, LTD

12013 Sara Road, Killam Industrial Park

Laredo, Texas 78045 U.S.A.

direct telephone number: (877) 330-0405

fax number: (877) 330-0404

- Provide as much information as possible that will help identify the need for repair
- Carefully pack the equipment in original packing cartons
- Clearly label all shipping cartons with the RGA number on the outside of cartons as well as on your packing slip, along with the reason for return
- Return general repairs by any convenient method. Send priority repairs by air freight
- You must prepay the transportation charges FOB Laredo, Texas, U.S.A.

### 1.5.1 Get an RGA Number

**RGA#** \_\_\_\_\_

If you are returning equipment to Branson, please call the Repair Department to obtain a Returned Goods Authorization (RGA) number. (At your request, the Repair Department will fax an RGA form to fill out and return with the equipment).

## 1.5.2 Record Information About the Problem

Before sending equipment for repair, record the following informations and send a copy of it with the equipment. This will greatly increase Branson's ability to address the problem.

1. Describe the problem; provide as much detail as possible. For example, is the problem intermittent? How often does it occur? How long before it occurs after powering up?

---

---

---

2. Is your equipment an automated system?

---

---

3. If the problem is with an external signal, which signal?

---

---

4. If known, include plug/pin # (e.g., P29, pin #3) for that signal:

---

---

5. What are the weld parameters?

---

---

---

6. What is your application? (Type of weld, plastic material, etc.)

---

---

---

---

7. Name and phone number of the person most familiar with the problem:

---

---

---

---

Contact the Branson office prior to shipping the equipment.

For equipment not covered by warranty, to avoid delay, include a Purchase Order.

Send a copy of this page with the equipment being returned for repair

## 1.5.3 Departments to Contact

Call your local Branson Representative, or contact Branson by calling, and asking for the appropriate department as indicates in [Table 1.5 Branson Contacts](#) below:

**Table 1.5** Branson Contacts

What you need help with or information about...	Whom to call	At this phone number...
Information about new welding systems or components	Your local Branson Rep or Branson Customer Service	203-756-0400 Ext 384
Application and Setup questions on the welding system	Welding Applications Lab	203-756-0400 Ext 368
Application assistance on the Horns and Tooling	ATG Lab	203-756-0400 Ext 495
Technical questions about the welding system	Welding Product Support	203-756-0400 Ext 355
Technical questions about Horns and Tooling	ATG Lab	203-756-0400 Ext 495
Ordering new parts	Parts Store	877-330-0406
RGA's, Request for Repair, Status of a Repair	Welding Repair Department	877-330-0405
System Automation/ hookup Information	Product Support	203-756-0400 Ext 355

My Local Branson Representative's name is:

---

I can reach this rep at:

---

## 1.5.4 Pack and Ship the Equipment

- Carefully pack the system in original packing material to avoid shipping damage. Plainly show the RGA number on the outside of cartons as well as inside the carton along with the reason for return. Make a list of all components pack in the box. KEEP YOUR MANUAL.
- Return general repairs by any convenient method. Send priority repairs by air freight. Prepay the transportation charges FOB the repair site.

NOTICE	
	Items that are sent Freight Collect will be refused.

## 1.6 Obtaining Replacement Parts

You can reach Branson Parts Store at the following telephone numbers:

Branson Parts Store

Direct telephone number: 877-330-0406

Fax number: 877-330-0404

Many parts can be shipped the same day if ordered before 2:30 p.m., Eastern time.

A parts list is found in [Chapter 7: Maintenance](#) of this manual, listing descriptions and EDP part numbers. If you need replacement parts, coordinate the following with your purchasing agent:

- Purchase order number
- 'Ship to' information
- 'Bill to' information
- Shipping instructions (air freight, truck, etc.)
- Any special instructions (for example, "Hold at the airport and call"). Be sure to give a name and phone number
- Contact name information



---

## **Chapter 2: Introduction**

---

<b>2.1</b>	<b>Models Covered . . . . .</b>	<b>16</b>
<b>2.2</b>	<b>Overview of this Model . . . . .</b>	<b>19</b>
<b>2.3</b>	<b>Features of the System. . . . .</b>	<b>20</b>
<b>2.4</b>	<b>Controls and Indicators . . . . .</b>	<b>22</b>
<b>2.5</b>	<b>Welding Systems . . . . .</b>	<b>23</b>
<b>2.6</b>	<b>Glossary of Terms. . . . .</b>	<b>25</b>

## 2.1 Models Covered

This manual covers the Branson 2000X Micro Actuator. The 2000X Micro Actuator and Interface Box are designed to be integrated into automated and semi-automated low force applications that require a small profile actuator. The Actuator and Interface Box may be found in one configuration:

Actuator and Interface Box alone (not installed in a common support, and so on). Being designed for automation, this is the usual presentation for this system.

This manual covers this configuration. The 2000X Micro Actuator requires a 2000Xdt power supply with 11.11 or higher software version to function, and that is covered in separate manuals and user documents.

[Figure 2.1](#) shows a Branson 2000X Micro Actuator and Interface Box.

NOTICE	
	The Actuator and Interface Box are a matched set, and must be kept together. They must not be interchanged with other micro systems.

**Figure 2.1** Frontal view of the 2000X Micro Actuator Power Supply Manual Set

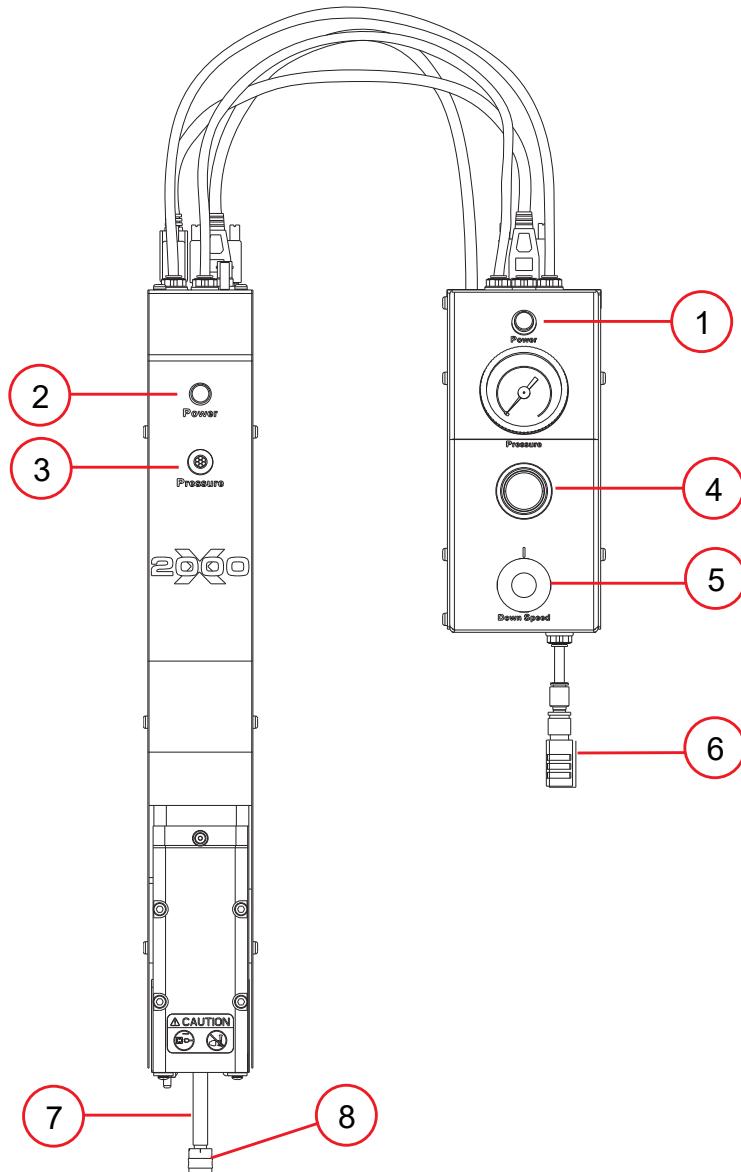

**Table 2.1** Frontal View of the 2000X Micro Actuator and Interface Box

Item	Description
1	Power Indicator Light
2	Power Indicator Light
3	System Pressure On Indicator
4	Air Pressure Adjust
5	Down Speed Control
6	Interface Box
7	Mechanical Stop Adjust
8	Actuator

The following documentation is available for the Branson 2000X-series Power Supplies that are compatible with the 2000X Micro Actuator:

- 2000X distance Power Supply Instruction Manual (EDP 100-412-167)
- 2000-Series Installation Guide (EDP 100-214-226)
- 2000X distance Quick Start User's Guide (EDP 100-412-169)

## 2.2 Overview of this Model

The 2000X Micro Actuator is a compact, rigid unit designed for use in manual, semi-automated, and automated ultrasonic welding systems. The Actuator can be mounted directly on an I-beam (or similar machine frame), or it can be mounted on a column and base with start switches and used in a manual or benchtop system. The Actuator is designed to be operated in an upright position, but is capable of running horizontally or inverted. If you are mounting your equipment in an inverted position, contact Branson for further recommendations. (See [1.5.3 Departments to Contact](#)).

The 2000X Micro Actuator requires a 2000X distance Power Supply for power and control of the Actuator's operation and to provide ultrasonic power to the Converter in the Actuator. The 2000X Micro Actuator is designed with remotely-mountable pneumatic controls. Operation of the 2000X Micro is controlled by inputs to the 2000X distance Power Supply. Having remote pneumatic controls allows easier user access to the Actuator settings, often important in automated systems. The pneumatics covered in this manual refer to the Interface Box, which is calibrated to operate as a system with the Actuator. If the Interface Box or Actuator are changed, the system must be fully recalibrated.

### The Carriage and Slide System

The 2000X Micro Actuator's carriage is driven by a double-acting air cylinder. It is mounted on a linear ball-bearing slide. The slide system is based on eight sets of preloaded, permanently lubricated bearings and provides consistent, precise alignment of the horn, smooth linear motion, and long-term reliability.

### The Pneumatic System

The pneumatic controls on the 2000X Micro are contained in the 2000X Interface Box, which is connected to the Actuator with three (3) 1/4-inch-OD poly tubing lines. The 2000X Micro Actuator's carriage and sheet-metal enclosure contains the air cylinder, which receives air pressure and control from the 2000X Interface Box. There is a pressure sensor in the Interface Box to allow the power supply to read the regulated air pressure.

The air pressure regulator, solenoid valves, and air pressure gauge are found in the Interface Box. Filtered factory air is connected to the 2000X Interface Box. The horn's rate of descent is adjusted by the Downspeed control on the Interface Box. The rate of return is fixed. For information on setting the Downspeed control, see [2.4 Controls and Indicators](#).

### Dynamic Triggering and Follow-Through

Many welding applications require force to be built up on the part before ultrasonic energy is activated. To achieve this, the Actuator contains a S-Beam load cell, located between the air cylinder and the converter, which initiates (triggers) ultrasonics after a preset force is applied to the part. Dynamic follow-through maintains a consistent force on the part during the weld collapse. This system helps provide uniform weld quality.

The dynamic triggering and follow-through process operates as follows: upon activation of the operating cycle, the solenoid valve delivers regulated air to the upper portion of the cylinder, and exhausts air through the Downspeed control from the bottom of the cylinder, causing the horn to advance and contact the workpiece. When the load cell measurement of the force on the part indicates part contact, and the desired trigger force is reached, a signal is sent to the Power Supply, which then starts the weld cycle. At this time, the actuator locks into a cycle, timing begins, and the palm buttons/start signal can be released. As melting of the plastic occurs, the S-Beam dynamic follow-through maintains consistent force on the part, ensuring smooth, efficient transmission of ultrasonic energy into the part.

## 2.3 Features of the System

Listed below are many features of the Branson 2000X-series ultrasonic welding system included in a 2000X Micro Actuator and 2000X distance Power Supply.

**Autotuning:** Branson Power Supply tuning ensures that the system is running at peak efficiency.

**Amplitude Stepping:** A patented Branson process, controlled by the Power Supply. At a specified time, energy, peak power, distance, or by external signal you can change the amplitude during the weld to control the flow of plastic. This feature helps ensure part consistency, higher strength parts and control of flash.

**Digital Horn Test Diagnostics:** In Test mode of the Power Supply, you can view the Horn Test results in digital form, using digital readouts and bar graphs on the Power Supply to give you the best picture of the stack's operation.

**Pretrigger:** This feature allows you to set the system weld controls to turn the ultrasonics on *before* contact with the part.

**Afterburst:** This feature allows you to set the system weld controls to turn the ultrasonics on *after* the weld and hold steps to release parts from the horn.

**Control Limits:** With some power supply models, these secondary controls are used in conjunction with the main parameters of the weld parameters. These user-programmed limits provide for adaptive control of the weld process.

**Process Alarm Display Showing Actual and Set Values:** When an alarm condition has occurred, you can view the value for the last weld and the suspect and reject settings you programmed into the controls.

**Post Weld Seek:** This system feature provides a short burst of energy at the end of the weld Hold and Afterburst steps to automatically retune the power supply, if required.

**Frequency Offset:** This process feature allows a user to set a frequency value, for certain specific applications, where the force imparted on the fixture or anvil causes a frequency shift in the Stack's operation. You should only use this feature when advised to do so by Branson.

**English (USCS)/Metric Units:** This feature allows the welder to be set up in the local units in use.

**Startup Diagnostics:** At power supply startup, the controls test the major system components, including the Actuator and its controls.

**Weld Parameter Entry:** User Setup is direct and easy, by selecting the menu parameter by name and using the keypad to enter the precise value. The controls also support entry by incrementing existing values.

**System Information Screen:** This is a screen that will give you information about your welding system (e.g., cylinder size, stroke length, number of cycles). Refer to this screen when contacting Branson for service and support.

**Ramp Starting:** The starting of the 2000X series power supply and horn is done at the optimum rate to reduce electrical and mechanical stress on the system. This also helps make some tough-to-start applications possible.

**True Wattmeter:** The controls on the power supply include a true wattmeter for accurate measurement of power and energy.

**Load Cell/Dynamic Follow Through:** Ensures the smooth, efficient transmission of ultrasonic energy into the part by maintaining horn/part contact and force during the weld.

**S-Beam Load Cell:** The load cell allows the ultrasonics to be triggered at a designated force input into the power supply.

**Encoder:** Allows the power supply to monitor the distance the horn has travelled, enabling the use of distance functions.

**Downspeed Control:** Regulates the rate of descent and force build-up on the part.  
**Pressure Sensor:** Allows the power supply to read the system pressure.

## 2.4 Controls and Indicators

The Actuator Controls and indicators for the 2000X Micro are found in two locations: on the Actuator or on the Interface Box. System controls and Actuator power are provided by the 2000X-series Power Supply.

The controls and indicators on the 2000X Micro Actuator are listed below.

- **S-Beam Load Cell:** Provides an indication of the force on a part during a weld. This indication can be used to determine when to trigger ultrasonics and also to produce a force/distance graph of the operating cycle
- **Pressure Indicator:** Indicates that the actuator is receiving pressurized air
- **Power Light:** Indicates that the Actuator is connected to the Interface Box, that Interface Box is connected to the Power Supply, and that the Power Supply's main power is on
- **Carriage Door:** Provides access to the converter-booster-horn stack; secured by four captive hex screws. Use an M4 T-handle wrench (EDP 200-128-028) to tighten the cap screws
- **Mechanical Stop:** Limits the stroke length to prevent the horn from contacting the fixture when no workpiece is in place; adjustment is approximately 0.025 in. (0.6 mm) per rotation; a locking ring keeps the setting from vibrating loose. Turning the knob clockwise increases the stroke length

CAUTION	General Warning
	The mechanical stop is not intended for welding distance.

CAUTION	General Warning
	Turning the mechanical stop too far can cause it to come out of the actuator.

Controls and indicators on the 2000X Interface Box are listed below.

- **Pressure Regulator:** Adjust the amount of air pressure applied to the cylinder; range of 5-80 psig (35-560 kPa). Tighten/loose knurled ring to block/allow setup
- **Downspeed Control:** Downspeed knob controls the rate of descent and force buildup on the part to be welded
- **Power Light:** Indicates that the Interface Box is connected to the power supply, and that the Power Supply's main power is on
- **Pressure Gauge:** Indicates the amount of air pressure applied to the cylinder. Adjust using the pressure regulator



## 2.5 Welding Systems

### Ultrasonic Plastics Welding

Thermoplastic parts are welded ultrasonically by applying high-frequency vibrations to the parts being assembled. The vibrations, through surface and intermolecular friction, produce a sharp rise in temperature at the welding interface.

When the temperature is high enough to melt the plastic, there is a flow of material between the parts. When the vibrations stop, the material solidifies under pressure and a weld results.

### The Plastics Welding System

The 2000X Micro welding systems consists of a power supply, a Micro Actuator, an Interface Box, and a converter-booster-horn stack. The system can perform a variety of ultrasonic welding operations, including: staking, spot welding, swaging, degating, and continuous operations. It is designed for use in automated, semi-automated, and/or manual production systems. Contact Branson for continuous operations or high duty cycles.

### Power Supply

The 2000X distance digital Power Supply converts conventional 50/60 Hz line current to high frequency electrical energy. It also contains all the electronic controls and can be located remotely from the Actuator and Interface Box. This allows the operator to adjust or reprogram the welding cycle remotely from the Actuator and related welding, tooling, and parts-handling systems.

The 2000X distance Power Supply also contains a DC power supply for electrical power to operate the electrical components and control circuits in the power supply, Interface Box and on the Actuator.

### Converter

The converter is mounted in the actuator as part of the ultrasonic stack. The ultrasonic electrical energy from the power supply is applied to the converter (sometimes called the transducer). This transforms the high frequency electrical oscillations into mechanical vibrations at the same frequency as the electrical oscillations. The heart of the converter are piezoelectric ceramic elements. When subjected to an alternating voltage, these elements alternately expand and contract, resulting in better than 90% conversion of electrical to mechanical energy.

### Booster

Success in ultrasonic assembly depends on the right amplitude of movement at the horn face. Amplitude is a function of horn shape, which is largely determined by the size and form of the parts to be assembled. The booster can be used as a mechanical transformer to increase or decrease the amplitude of vibrations applied to the parts through the horn. The booster is a resonant half-wave section of aluminum or titanium. It is mounted between the converter and the horn, as part of the ultrasonic stack. It also provides a clamping point for rigid stack mounting.

Boosters are designed to resonate at the same frequency as the converter with which they are used. Boosters are usually mounted at a nodal (minimum vibration) point of axial motion. This minimizes the loss of energy and prevents vibration from being transmitted into the actuator.

## Horn

The horn is selected or designed for a specific application. Each horn is tuned typically as a half-wave section that applies the necessary force and vibration uniformly to the parts to be assembled. It transfers ultrasonic vibrations from the converter to the workpiece. The horn is mounted to the booster as part of the ultrasonic stack.

Depending on their profile, horns are referred to as stepped, conical, exponential, bar, or catenoidal. The shape of the horn determines the amplitude at the face of the horn. Depending on the application, horns can be made from titanium alloys, aluminum, or steel. Titanium alloys are the best materials for horn fabrication due to their high level of strength and low loss. Aluminum horns are usually chrome- or nickel-plated or hard-coated to reduce wear. Steel horns are for low amplitude applications requiring hardness.

## S-Beam Load Cell and Dynamic Follow Through

The Load Cell measures and records the force being applied to the part, this measurement determines the force at which ultrasonic energy is applied. The load cell and cylinder assembly ensures that pressure is applied to the part prior to the application of ultrasonic energy. To maintain horn-to-part contact and force as the joint collapses, the load cell assembly provides dynamic follow-through. As the plastic melts, the load cell assembly ensures smooth transmission of ultrasonic energy into the part.

## Encoder

The encoder measures the distance the horn has traveled. Depending on the power supply settings, it can:

- Allow for distance welding in absolute and collapse modes
- Detect improper setup controls
- Monitor the distance data of the weld

## 2.6 Glossary of Terms

The following terminology may be encountered when using a 2000X-series ultrasonic welding system. Some of these terms may not be available in all Controls (Power Supply model) configurations:

**Table 2.2** Glossary of Terms

Name	Description
AB Amplitude	The amplitude at the horn face during the afterburst step.
AB Delay	Time delay between the end of the hold and the start of an afterburst.
AB Time	The duration of the afterburst.
Abort Current Printing	Terminates the current printing request.
Absolute Cutoff	Ends the ultrasonic portion of the cycle when the set absolute distance is reached.
Absolute Distance	The distance the horn has traveled from home (ULS deactivation).
Absolute Mode	A mode in operation in which the ultrasonic portion of the cycle is terminated when a user-specified distance from home has been reached.
Absolute Position	The position of the actuator after clearing the Upper Limit Switch (home position).
Actual	A reported value that occurred during the weld cycle. The converse is the set parameter that was requested during the setup.
Afterburst	Ultrasonic energy applied after the hold step. Used to break away sticking parts from the tooling.
Alarm Beeper	An audible signal that sounds when a general alarm has occurred.
Amplitude	The peak-to-peak movement at the horn face. Always expressed as a percentage of the maximum.
Amp A	The amplitude applied to the part from the start of the weld to the end of the weld.
Amp B	The amplitude applied to the part from the step change to the end of the weld.
Amplitude Graph	A graph of amplitude percentage plotted against time.
Amplitude Step	A change in amplitude during the ultrasonic portion of the cycle.
Amp Control	The ability to set amplitude digitally or by an external control.
Automatic	A pretrigger condition indicating that pretrigger engages when the actuator leaves the upper limit switch.

**Table 2.2** Glossary of Terms

Name	Description
Baud Rate	The rate of data transmission over the serial communication port.
Beep	An audible signal produced by the Branson control board. Used to alert the operator to an unexpected condition.
Booster	A one-half wavelength long resonant metal section mounted between the converter and horn, usually having a change in cross-sectional area between the input and output surfaces. Mechanically alters the amplitude of vibration at the driving surface of the converter.
Cold Start	A condition that restores a setup to its default values.
Collapse Distance	The vertical distance your part will be collapsed before termination of ultrasonics.
Collapse Mode	A mode of operation in which the weld is terminated when the part has been collapsed by a user specified distance.
Control Limits	Additional parameters that determine the end of the ultrasonic portion of the cycle and the move to the hold state.
Converter	The device that converts the electrical energy into mechanical vibrations at a high frequency (an ultrasonic rate). The converter is a central component of the welding system and is mounted in the Actuator.
Counters	A record of the number of cycles run by category, for example, alarms, good parts, and so on, recorded on the Power Supply.
Digital Filter	A smoothing technique used to provide more meaningful data.
Down Speed	The user-definable speed of descent (percentage of maximum speed) during the down stroke of the Actuator.
Energy Mode	A mode of operation in which ultrasonics are terminated at a user-specified energy value.
External Amplitude Control	Enables you to access real-time amplitude control directly.
External Frequency Control	Enables you to access real-time frequency control directly.
Form Feed	When using a printer with the 2000Xd Power Supply, a form feed is inserted after print setup or print graph, or after the number of lines per page is reached.
Frequency	The operating frequency of the ultrasonic stack. The frequency stored is measured at the end of the ultrasonic portion of the cycle (when ultrasonics are terminated).

**Table 2.2** Glossary of Terms

Name	Description
Freq End	The frequency at the end of the ultrasonic portion of the welding cycle (when ultrasonics are terminated).
F Actual	The actual running frequency of the acoustic system.
F Memory	The frequency stored in the Power Supply memory.
Frequency Offset	An offset factor applied to the ultrasonics frequency stored in the Power Supply.
General Alarm	An alarm that occurs due to system fault and/or tripping a limit.
Ground Det. Cutoff	Ground Detect Cutoff. Immediately terminates the weld process, including the hold step, when a ground detect has occurred.
Gnd Det. Mode	Ground Detect Mode, available in all models of 2000X power supplies. In this mode of operation, ultrasonics are terminated after detection of a ground condition between the horn and fixture or anvil.
Hold Force	The force on the part during the hold portion of the cycle.
Hold Time	The duration of the hold step.
Horn Down	A mode in which ultrasonics are locked out and the user can advance the Actuator for setup and alignment.
Linear Encoder	Provides carriage (horn) distance measurement during the Actuator cycle.
Lines per Page	When using an optional Printer, the number of welds per printed page.
Load Cell	Provides force measurement for accurate ultrasonic triggering and graphing of force.
Main Menu	The list of features available in the software.
Max Energy	Maximum Energy. The maximum user-specified energy that produces a part without an alarm.
Min Energy	Minimum Energy. The minimum user-specified energy that produces a part without an alarm.
Minus Limit	The user-defined lower limit, or lower extreme of an acceptable range for a given parameter. See Control Limits in the Power Supply manual.
Missing Part	A min/max distance where trigger is expected. Returns the Actuator to the home position and displays an alarm indicating that the cycle was aborted because no part was present.
Parameter Range	Valid range of parameters accepted for a particular setup.
Parameter Step	Ability to dynamically change amplitude during the weld cycle.

**Table 2.2** Glossary of Terms

Name	Description
Password	A user-defined access code for the secure areas of the Power Supply user's controls.
Password Protection	Enables lock-out of the Power Supply's weld parameter modification by using a user-defined password.
Peak Power Cutoff	A power value that terminates the ultrasonics when peak power is not the primary control mode.
Pk Pwr Mode	Peak Power Mode. A mode of operation in which ultrasonics are terminated at a user-specified power value in percentage of maximum.
Plus Limit	The user-defined upper limit. See Control Limits, Suspect, Reject and Missing Part Limits in the Power Supply manual.
Post Weld Seek	Used to determine the operating frequency of the Stack, after the Hold and/or Afterburst portion of the weld cycle. Ultrasonics are run at a low level (5%) amplitude during this step, and the frequency is stored to memory.
Power Graph	A printed graph of power in percentage maximum plotted against time.
Preset	A method of saving the power supply's user-set parameters to memory, for a given Setup. The Power Supply model may allow multiple presets for easy recall of a Setup's parameters, for a given part, process or operation. Presets can be labeled by the user or the system.
Preset Name	The ability to name a preset in customer-defined terms.
Pretrigger	The setting that causes ultrasonics to start before contact with the part (or, before the set Trigger Force has been met).
Pretrig Amp	Pretrigger amplitude. The amplitude at the converter during pretrigger.
Print on Alarm	Allows the user to set up printing automatically when an alarm occurs.
Print on Sample	Allows the user to set up printing automatically based on the number of cycles performed.
Ready Position	State in which the welder is retracted to the home position and ready to receive the start signal, ready to operate.
Recall Preset	Allows the user to activate a preset from memory for purposes of operation or modification.
Reject Limits	User-definable limits at which the violating cycle is identified as having produced a bad part.

**Table 2.2** Glossary of Terms

Name	Description
Required	State used with limits indicating that a reset will be required when the limit is exceeded. The reset is accomplished by using the reset key on the front of the Power Supply.
Reset Required	State used with limits indicating that a reset will be required when the limit is exceeded. The reset is accomplished by using the reset key on the front of the Power Supply, or by external reset at the User I/O.
Run Screen	The screen showing weld status, alarms, weld count, and process information.
Save Preset	Stores a programmed set of weld parameters as a Preset.
Scrub Time	In Ground Detect mode, the amount of time after detection of a ground condition to the termination of ultrasonics.
Seek	The activation of ultrasonics at a low-level (5%) amplitude, for the purpose of finding the resonant frequency of the Stack.
Serial Port	A RS232 port provided to you for external data communications.
Step @ Col	User-definable collapse distance at which AmpA is changed to AmpB.
Step @ Energy	User-definable point at which AmpA is changed to AmpB.
Step @ Ext Sig	Allows you to shift either force or amplitude based upon an external signal.
Step @ Power	User-definable point at which AmpA is changed to AmpB.
Step @ Time	User-definable point at which AmpA is changed to AmpB.
Suspect Limits	User-definable limits used to identify a part as being potentially bad (suspect).
Test Scale	The magnification of the power bar on the front panel of the Power Supply, useful for lower-power applications that want a more accurate (but smaller scale).
Time Mode	Terminates the ultrasonics at a user-specified time.
Timeout	A time at which the ultrasonic energy terminates if the main control parameter has not been reached.
Trigger Beeper	An audible signal sounded when the trigger force has been met.
Trig Delay	Trigger Delay. A user-programmable time delay between engagement of the trigger and start of ultrasonics and ramping of force to the weld force.

**Table 2.2** Glossary of Terms

Name	Description
User-defined Limits	<p>For process resultants, where - is the user-defined lower limit, and + is the user-defined upper limit:</p> <ul style="list-style-type: none"> <li>• ± S/R Energy: The energy reached during the weld</li> <li>• ± S/R Freq: The peak frequency reached during a weld</li> <li>• ± S/R Power: The peak power as a percentage of the maximum reached during the weld</li> <li>• ± S/R Abs D: The Absolute distance reached during the weld from the Upper Limit Switch</li> <li>• ± S/R Col D: The collapse distance reached from trigger to end of weld</li> <li>• ± S/R Trg D: The distance at which the trigger occurred</li> <li>• ± S/R Time: The weld time reached during the weld</li> </ul>
Weld Count	Count of acceptable weld cycles.
Weld Energy	The energy specified to be applied to the part during the weld cycle.
Weld History	The last 50 weld summary data lines are saved.
Weld Scale	The power bar LED scale during weld.
Weld Results	A one-line summary of information concerning the last weld cycle.
Weld Time	The time for which ultrasonics are on.



---

## Chapter 3: Delivery and Handling

---

<b>3.1</b>	<b>Shipping and Handling</b> . . . . .	<b>32</b>
<b>3.2</b>	<b>Receiving</b> . . . . .	<b>33</b>
<b>3.3</b>	<b>Unpacking the Actuator and Interface Box</b> . . . . .	<b>34</b>
<b>3.4</b>	<b>Returning Equipment</b> . . . . .	<b>35</b>

## 3.1 Shipping and Handling

### 3.1.1 Environmental Specifications

The 2000X Micro Actuator is a system of machined and electro-pneumatic components that move the ultrasonic tooling in the ultrasonic welding system and control aspects of the weld process. Many of its components can be harmed if the unit is dropped, shipped under improper conditions, or otherwise mishandled. The following environmental guidelines should be respected in the shipping of the 2000X Micro Actuator unit.

**Table 3.1** Environmental Specifications

Environmental Condition	Acceptable Range
Humidity	Maximum 95%, non-condensing
Storage / Shipping Temperature	-25° C/-13° F to +55° C/+131° F (+70° C/+158° F for 24 hours).
Shock / Vibration (transit)	50 g shock / 0.5 g and (3-100 Hz) vibration per ASTM 3332-88 and 3580-90.

## 3.2 Receiving

Branson equipment is carefully checked and packed before dispatch. It is recommended, however, that you follow the procedure below upon receiving your Micro Actuator and Interface Box.

### Inspect the Actuator when it is delivered

**Table 3.2** Receiving

Step	Action
1	Check the equipment immediately after delivery to ensure that it has not been damaged during transport.
2	Verify that all parts are complete according to the delivery note.
3	Determine if any component has become loose during shipping and, if necessary, tighten screws.

NOTICE	
	If the goods delivered have been damaged during shipping, please contact the forwarding agent immediately. Retain packing material (for possible inspection or for sending back the unit).

CAUTION	
	The Actuator, Interface Box and the Power Supply may be heavy. Handling, unpacking, and installation may require the assistance of a colleague or the use of platforms or hoists.

## 3.3 Unpacking the Actuator and Interface Box

The Actuator and Interface Box are shipped in a rigid cardboard box using protective foam shells for support. for the complete unpacking and installation procedure, refer to [Chapter 5: Installation and Setup](#).

### 3.4 Returning Equipment

If you are returning equipment to Branson Ultrasonics Corporation, please call your Customer Service Representative to receive approval to return goods.

If you are returning equipment for repair, refer to [Chapter 1: Safety and Support](#), Section [1.5 Returning Equipment for Repair](#), of this manual, for appropriate procedure.



---

## Chapter 4: Technical Specifications

---

4.1	Technical Specifications . . . . .	38
4.2	Physical Description . . . . .	39

## 4.1 Technical Specifications

### 4.1.1 Requirement Specifications

The 2000X Micro Actuator requires compressed air. The factory air source must be “clean (5 micron) and dry”, that is, does not include moisture or lubricants. The Actuator requires 70 psi minimum pressure for operation and cooling, and can require up to 80 psig maximum, depending on the application. The following table lists environmental specifications for the ultrasonic welder.

**Table 4.1** Environmental Specifications

Environmental Concern	Acceptable Range
Humidity	Maximum 95%, non-condensing
Operating Altitude	Up to 6560 ft (2000 m)
Ambient Temperature	+5° C to +50° C (+41° F to +122° F).
Storage/Shipping Temperature	-25° C/-13° F to +55° C/+131° F (+70° C/+158° F for 24 hours).

All electrical input power connections are to the Power Supply.

### 4.1.2 Performance Specifications

The following table details some of the performance specifications associated with the 2000X Micro Actuator.

**Table 4.2** 2000X Micro Actuator Performance Specifications

Performance Specifications	
Maximum clamping force on part (at 80 psig / 550 kPa)	115 lbs / 511 N
Dynamic triggering range	5-115 lbs / 22.2-511 N
Dynamic follow-through	40 lbs to max clamp force
Maximum traverse speed	7 inch / 177.8 mm per sec. max at 1.75" / 44.4 mm stroke, 80 psi
Minimum stroke	0.25 inch / 6.3 mm
Maximum stroke	1.75 inch / 44.4 mm



## 4.2 Physical Description

Refer to [Chapter 5: Installation and Setup](#) for dimensional information

### 4.2.1 Standard Items

#### Slide Mechanism

The slide mechanism is based on eight sets of preloaded, permanently lubricated bearings, proving consistent, precise alignment of the horn, smooth linear motion, and long-term reliability.

#### Limit Switch, Function

The solid state Upper Limit Switch (ULS) signals the control circuits in the Power Supply that the carriage has returned to the top of its stroke (home) and is ready to start another operating cycle.

The Power Supply uses ULS signal to perform various control functions, as in the following examples:

- Indexing Control: In automated systems, the Linear Encoder generates an Actuator Clear signal at a preset distance along the travel of the horn. This signal can be used to trigger a safety interlock switch, controlling movement of the material handling equipment (indexing) before the horn is fully retracted
- Electronic Pretriggering: A 2000X-series Power Supply can use the ULS signal to activate ultrasonics before the horn contacts the workpiece. Pretriggering is used with large or difficult-to-start horns and in specialized applications

#### Mechanical Stop

The mechanical stop limits the downward travel of the horn. to prevent equipment damage, adjust the stop so that the horn will not contact the fixture when no workpiece is in place. The mechanical stop knob is graduated to represent the stroke adjustment per turn. The adjustment in 0.025 inch (0.635 mm) per turn. Turning counterclockwise increases the stroke; turning clockwise will shorten the stroke. It is not intended for use in welding by distance.

CAUTION	General Warning
	<p>Do not run the Actuator with the locking nut loose. It may cause ULS alarms and affect the force readings.</p>

#### S-Beam Load Cell and Dynamic Follow Through

The S-Beam Loaded Cell measures the force being applied to the part of the trigger ultrasonics and record the welding parameters. The S-Beam load cell assembly ensures that pressure is applied to the part prior to the application of ultrasonic energy.

To maintain horn-to-part contact and force as the joint collapses, the S-Beam load cell assembly provides dynamic follow-through. As the plastic melts, the S-Beam load cell assembly ensures smooth transmission of ultrasonic energy into the part.

## Linear Encoder

The encoder measures the distance the horn has travelled. Depending on the Power Supply settings, it can:

- Allow for distance welding
- Detect improper setup controls
- Monitor the quality of the weld
- Decrease cycle time by generating signal to initiate indexing of material equipment before horn is fully retracted

## Pneumatic System

The pneumatic system is contained within the Actuator and the interface box. The system consists of:

1. Air cylinder
2. Pressure indicator
3. Pressure regulator
4. Pressure gauge
5. Primary solenoid valve
6. Down speed flow control valve
7. Silencer

The horn's rate of descent (downspeed) is adjusted at the front of the interface box using the Downspeed control knob. The rate of ascent is fixed. Refer to [Figure 4.1](#) for a schematic of the pneumatic system.

**Figure 4.1** 2000X Micro Actuator Pneumatic System

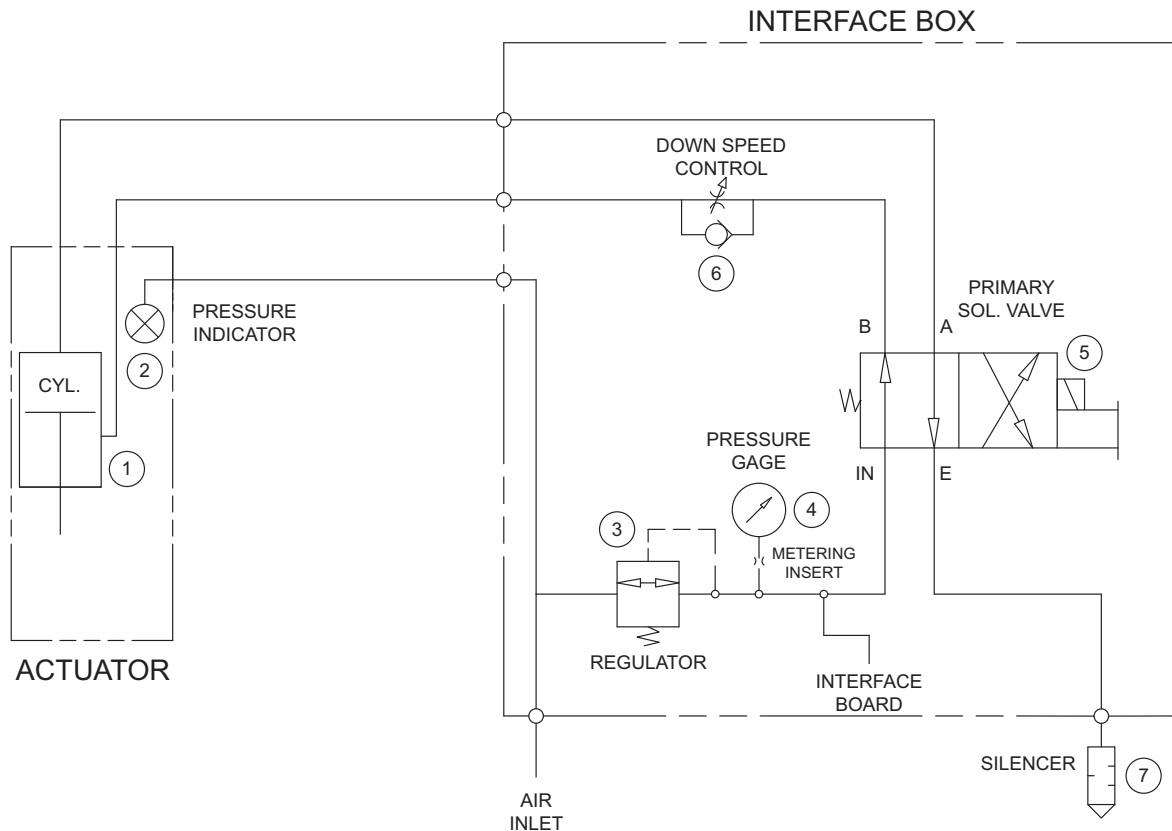

---

## Chapter 5: Installation and Setup

---

5.1	About Installation. . . . .	42
5.2	Handling and Unpacking. . . . .	43
5.3	Take Inventory of Small Parts . . . . .	45
5.4	Installation Requirements . . . . .	46
5.5	Installation Steps . . . . .	52
5.6	Safety Equipment . . . . .	60
5.7	Assembly the Acoustic Stack . . . . .	61
5.8	Testing the Installation . . . . .	65
5.9	Still Need Help? . . . . .	66

## 5.1 About Installation

This chapter is intended to help the installer with the basic installation and setup of your new 2000X Micro Actuator.

CAUTION	General Warning
	The Actuator, Interface Box, Power Supply and related components are heavy. Handling, unpacking, and installation may require the assistance of a colleague or the use of lifting platforms or hoists.

International safety labels are found on the power supply, interface box, and actuator. Those that are of importance during installation of the system are identified in the figures in this and other chapters of the manuals.

## 5.2 Handling and Unpacking

If there are any visible signs of damage to the shipping containers or the product, or you later discover hidden damage, NOTIFY YOUR CARRIER IMMEDIATELY. Save the packing material.

1. Unpack the 2000X-series components as soon as they arrive. Refer to the following procedure
2. Verify you have all of the equipment ordered. Some components are packed inside other boxes
3. Inspect the controls, indicators, and surfaces for signs of damage
4. Save all packing material. Evaluation systems will be returned using this packing material

### 5.2.1 Actuator

The Actuator and interface box are shipped assembled and ready to install.

1. Move the shipping container close to the intended installation location, leave it on the floor
2. Unpack the actuator, interface box, cables, and tool kit from their cardboard box and set the box aside
3. The converter and/or booster are shipped in a separate shipping box(es). Unpack the converter and/or booster from their packages
4. Save the packing material

NOTICE	
	The Actuator and Interface Box are a matched set, and must be kept together. They must not be interchanged with other micro systems.

NOTICE	
	The packaging may also include the converter and/or booster, if ordered.

**Figure 5.1** Ultrasonic Converter (J-Type for Stand Alone Use) and Booster

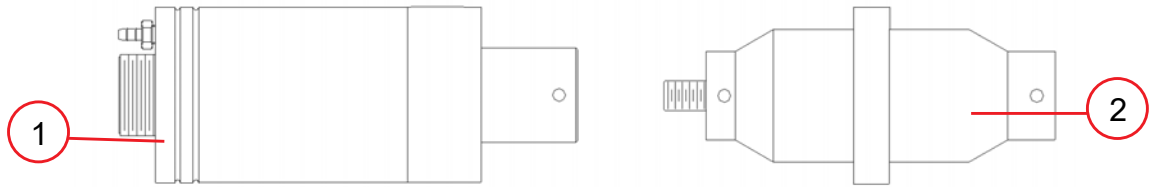

**Table 5.1** Ultrasonic Converter

Item	Description
1	Converter (J-type shown)
2	Booster

## 5.3 Take Inventory of Small Parts

Small Parts included (=x).

**Table 5.2** Power Supply and/or Actuator Assemblies

Part or Kit	2000X Power Supply 40 kHz	Actuator
40 kHz Spanners (2)	x	
Silicone Grease	x	
T-Handle Wrench, Micro Actuator M4		x
Actuator Mtg. Bolts (2)		x
Actuator Mtg. Washers		x
5/64 Allen Wrench		x

### 5.3.1 Cables

Two cables connect the actuator and interface box: the encoder cable, and the control cable. The power supply provides control signals to the interface box via the actuator interface cable, and supplies ultrasonic energy to the actuator through the RF cable. If the system is to be automated, you may also need a J911 start cable and a user I/O cable. Check your invoice for cable types and cable lengths.

**Table 5.3** List of Cables

EDP	Description
100-240-365	Control Cable
100-240-364	Encoder Cable
101-241-203	Actuator Interface, 8' (J925S)
101-241-204	Actuator Interface, 15' (J925S)
101-241-207	Alarm I/O, 8' (J957S)
101-241-208	Alarm I/O, 15' (J957S)
101-240-020	Start Cable (J911) 8' (req PLA)
101-240-015	Start Cable (J911) 15' (req PLA)
101-241-248	Terminal - 8'
101-241-249	Terminal - 15'
101-240-179	RF, 8' CE SHV (J934C)
101-240-181	RF, 15' CE SHV (J934C)
100-246-630	Ground Detect Cable
100-143-043R	Printer, 6'

## 5.4 Installation Requirements

### 5.4.1 Location

The Actuator may be installed in a variety of positions. It is usually mounted directly on automated or semi-automated equipment. It may be manually or automatically loaded and unloaded.

The interface box may be located up to 3 feet away from the Actuator. The power supply can be located up to 15 feet from the Actuator. The power supply must be accessible for user parameter changes and settings, and must be placed in an horizontal orientation. The power supply should be positioned so it does not draw in dust, dirt or material via its rear fans. Refer to the illustrations on the pages that follow for a dimensional drawing of each component. All dimensions are approximate and may vary between models.

NOTICE	
	<p>The Interface Box on the 2000X Micro Actuator can be located at a maximum of 3 feet from the Actuator.</p>

[Figure 5.2 Power Supply Dimensional Drawing](#)

[Figure 5.3 2000X Micro Actuator and Interface Box Dimensional Drawing](#)

### 5.4.2 Environmental Specification

**Table 5.4** Environmental Specifications

Environmental Concern	Acceptable Range
Humidity	Maximum 95%, non-condensing
Operating Altitude	Up to 6560 ft (2000 m)
Ambient Operating Temperature	+5° C to +50° C (41° F to 122° F)
Storage / Shipping Temperature	-25° C to +55° C (-13° F to + 131° F); Up to +70° C (+158° F) for 24 hours



**Figure 5.2** Power Supply Dimensional Drawing

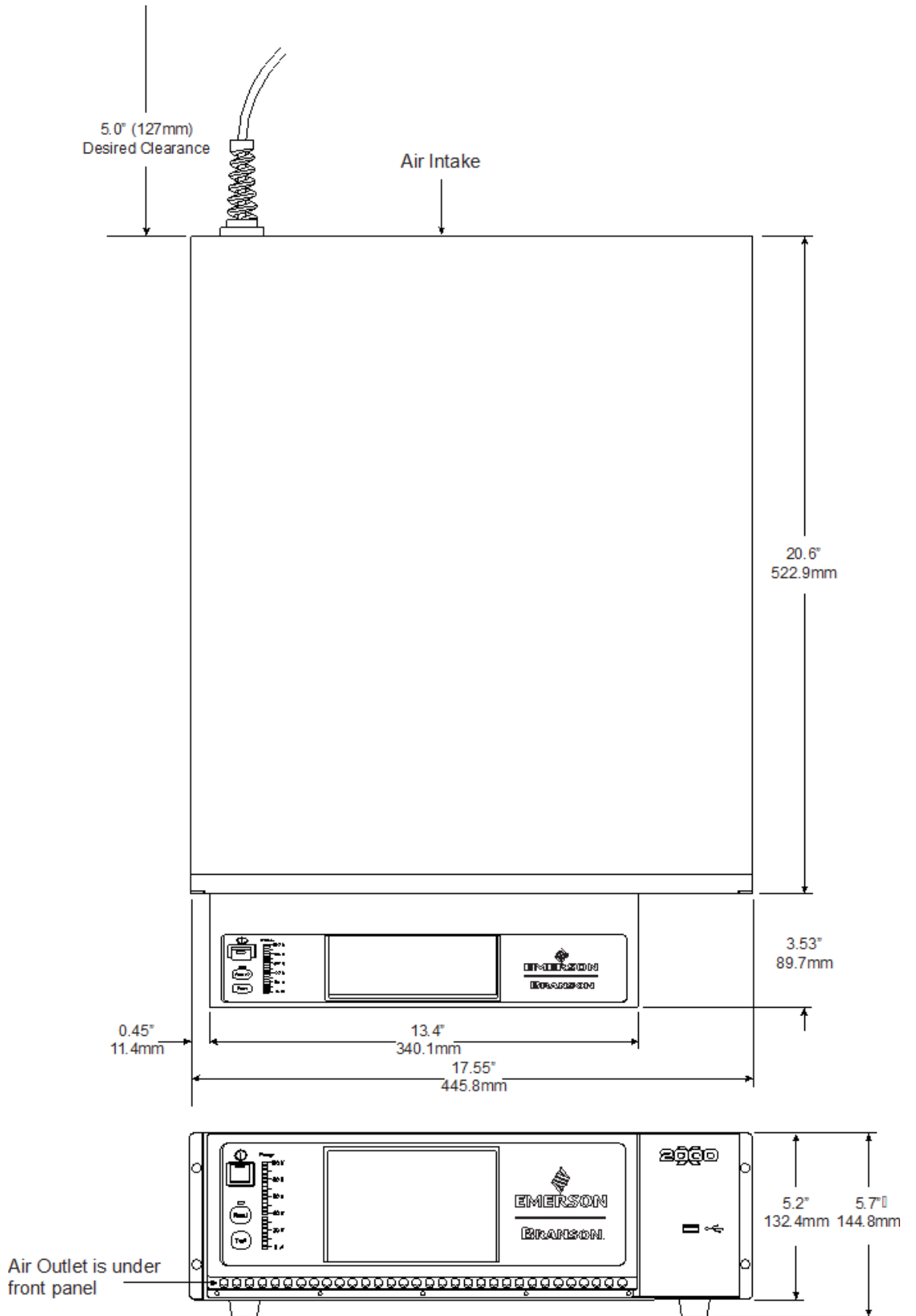

**Figure 5.3** 2000X Micro Actuator and Interface Box Dimensional Drawing

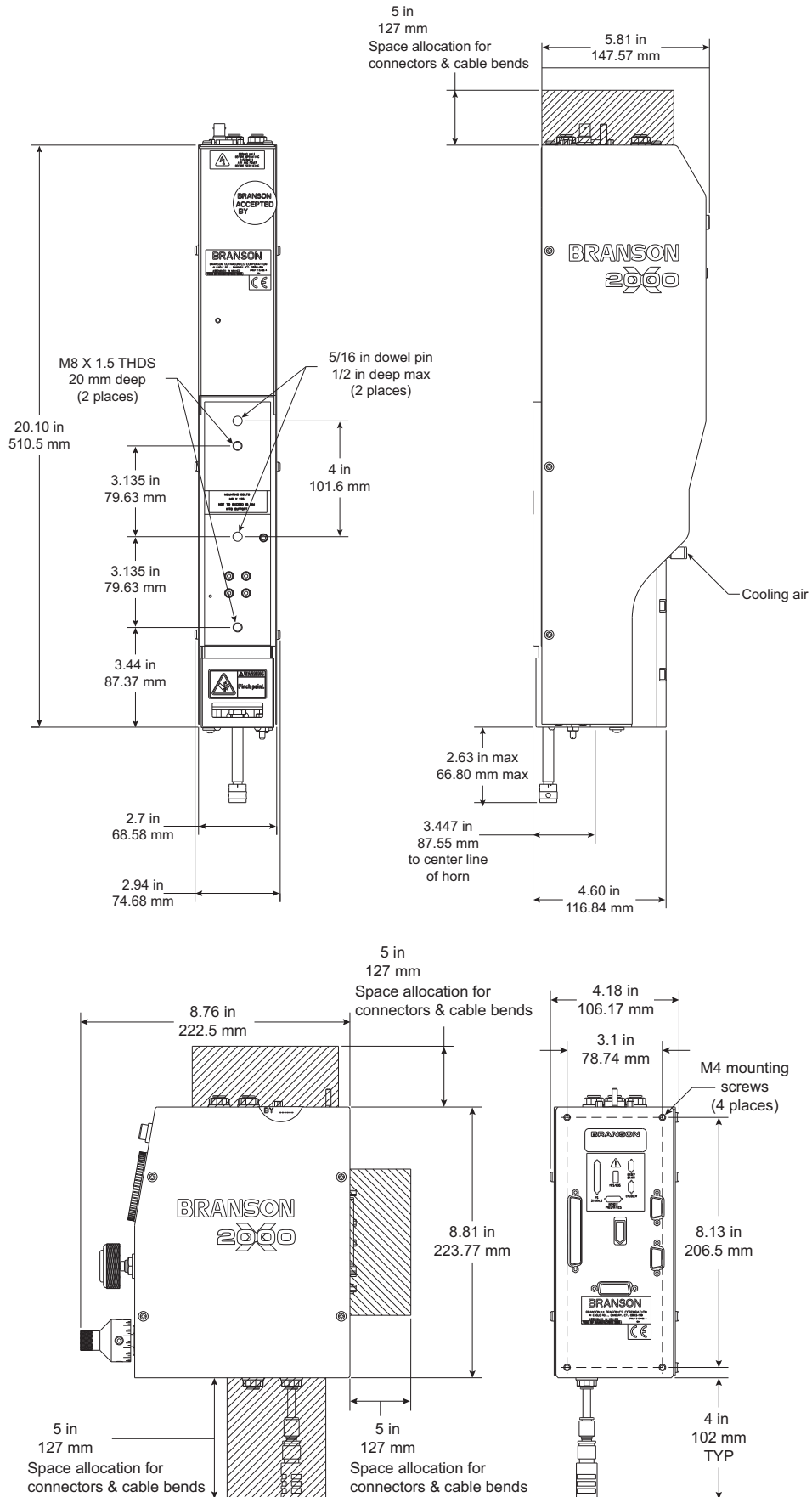

**Figure 5.4** Block Wiring Diagram

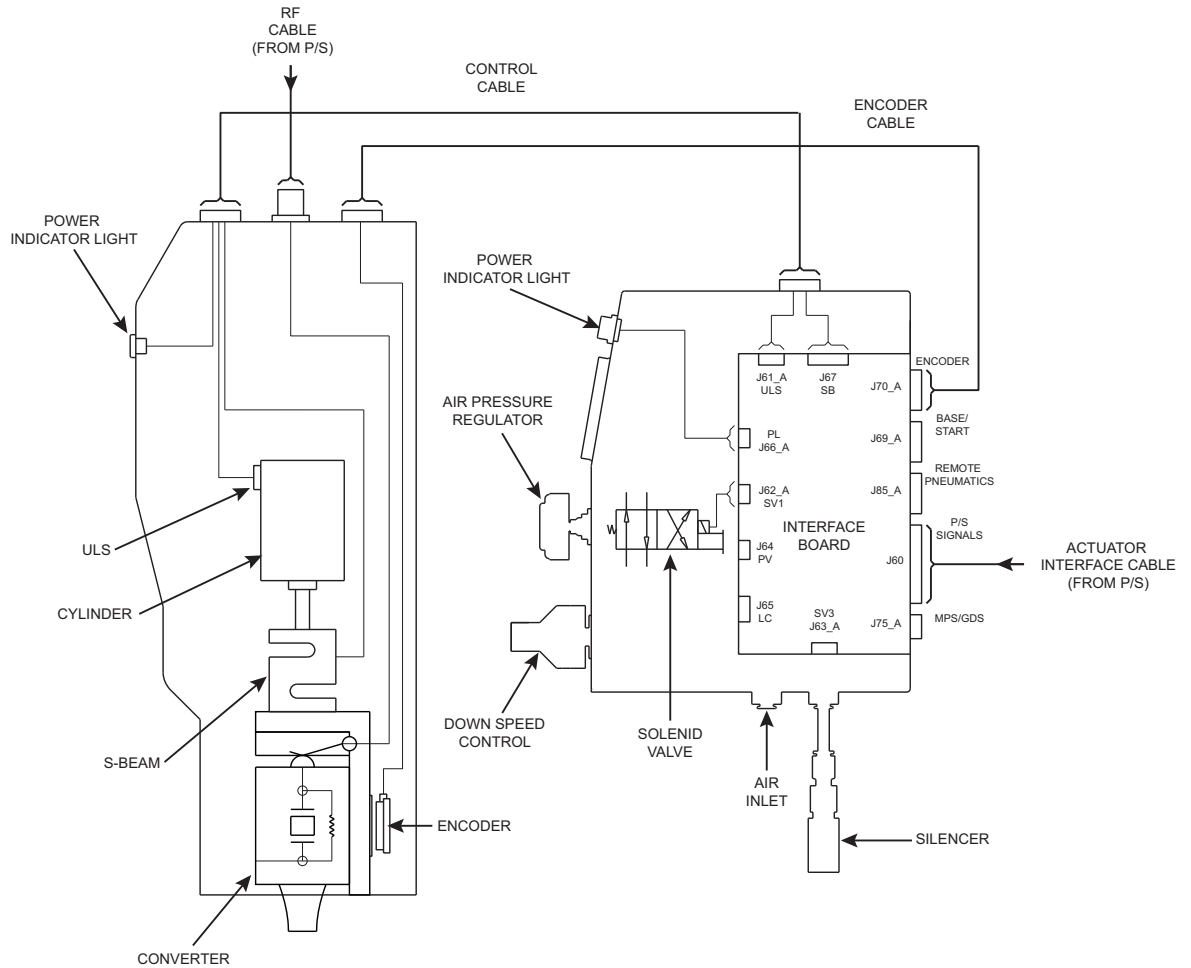

### 5.4.3 Electrical Input Power Ratings

Plug the Power Supply into a single-phase, grounded, 3-wire, 50 or 60 Hz power source. [Table 5.5 Input Power requirements](#) lists the current and fuse ratings for the various models.

The ground screw on the rear of the Actuator must be connected to earth ground with #8 gauge wire.

**Table 5.5** Input Power requirements

Model	Input Voltage	Maximum Current	Fuse
40 kHz/800 W	100V-120V	10A	20 A
	200V-240V	5A	
40 kHz/400 W	100V-120V	5A	

## 5.4.4 Air Cylinder Consumption

Cubic Feet of air per Minute (CFM) per inch of stroke length (each direction) for a 40 mm bore cylinder.

**Table 5.6** Air Cylinder Consumption

Air Pressure	CFM
10	0.00174
20	0.00243
30	0.00312
40	0.00381
50	0.00450
60	0.00513
70	0.00590
80	0.00660

Use the table above to calculate the air used by the air cylinder.

Add 0.034 cubic feet per second (2CFM) to account for converter cooling air (continuous cooling) per cycle.

Example:

400 mm bore Micro Actuator running at full pressure (80 psi) and stroke length (1.75") at a cycle rate of 20 parts per minute = 0.0066 CFM per inch of stroke (from table) 3.5" (total stroke is 1.75" down and 1.75" back) equals 0.023 CFM per stroke

Cycle rate is 20 parts per minute, so: 0.023 CFM by 20 (parts per minute) = 0.462 CFM

Add 2 CFM to account for converter cooling air (continuous cooling) for a total of 2.5 CFM.

The example above is to be considered a worst case condition for a Micro Actuator to run at.

## 5.4.5 Factory Air

The factory compressed air supply must be "clean (to a 5 micron level), dry and unlubricated" air with a regulated maximum pressure of 80 psig (552 kPa). Depending on your applications, the actuator requires between 35 to 80 psi. The 2000X Micro Actuator and Interface Box require a customer-provided air filter which protects from particulate matter of 5 microns or larger. Follow the air filter manufacturer's recommendations for installing and maintaining your air filter. A quick-disconnect fitting is suggested. Use a lock - out device on the air line if required.

### 5.4.5.1 Pneumatic Tubing and Connectors

Actuator assemblies are not externally plumbed from the factory, but provide conventional 1/4 - inch OD pneumatic tubing connection at the air inlet.

If making connections for an actuator, or if re - plumbing your system for a new air filter location, you must use 1/4 - inch OD tubing and connectors rated above 80 psi (use Parker "Parflex" 1/4 OD x 0.040 wall, type 1, grade E5, or equivalent), and appropriate connectors.

#### 5.4.5.2 Pneumatic Connections to Actuator

Pneumatic connections to the 2000XMicro actuator are identified as cylinder top, cylinder bottom, pressure indicator and converter cooling (at the front of the Actuator). The interface box houses the main air inlet and exhaust, along with the 3 output air connections to the Actuator.

WARNING	General Warning
	Filtered cooling air (80 SCHF) must be provided to the Actuator through the air inlet located at the front of the Actuator. Failure to connect cooling air may void product warranty. Consult with a Branson representative if you have any questions.

You must provide an air filter assembly to the remote box which will support at least 80 psig and remove particulate matter of 5 microns or larger.

## 5.5 Installation Steps

WARNING	General Warning
	<p>This product is heavy and can cause a pinching or crushing injury during installation or adjustment. Keep clear of moving parts.</p>

The Actuator is intended for installation on your custom-made mounting support.

For the standard 2000X Micro Actuator, it is located in place with a mounting pin and secured using two metric bolts.

1. Lift the Actuator from the box. Carefully lay the assembly on its side
2. Install the mechanical stop. See section [5.5.1 Installing the Mechanical Stop](#)
3. Use of guide pins is suggested. They are not provided with the Actuator. If you require guide pins, use solid metal dowel pins, 8 mm diameter, which must not extend into the actuator more than 0.40 inch (10 mm) into your Actuator

CAUTION	General Warning
	<p>The Actuator supports bolts for the 2000X Micro Actuator are metric, M8 x 1.25 thread pitch, 22 mm long. The support pin and mounting bolts must not extend more than 0.62 in (15 mm) into the Actuator, otherwise, binding or damage to the carriage may occur.</p>

**Figure 5.5** Rear view of Actuator, showing Mounting Surface, Bolt and Guide Pin locations

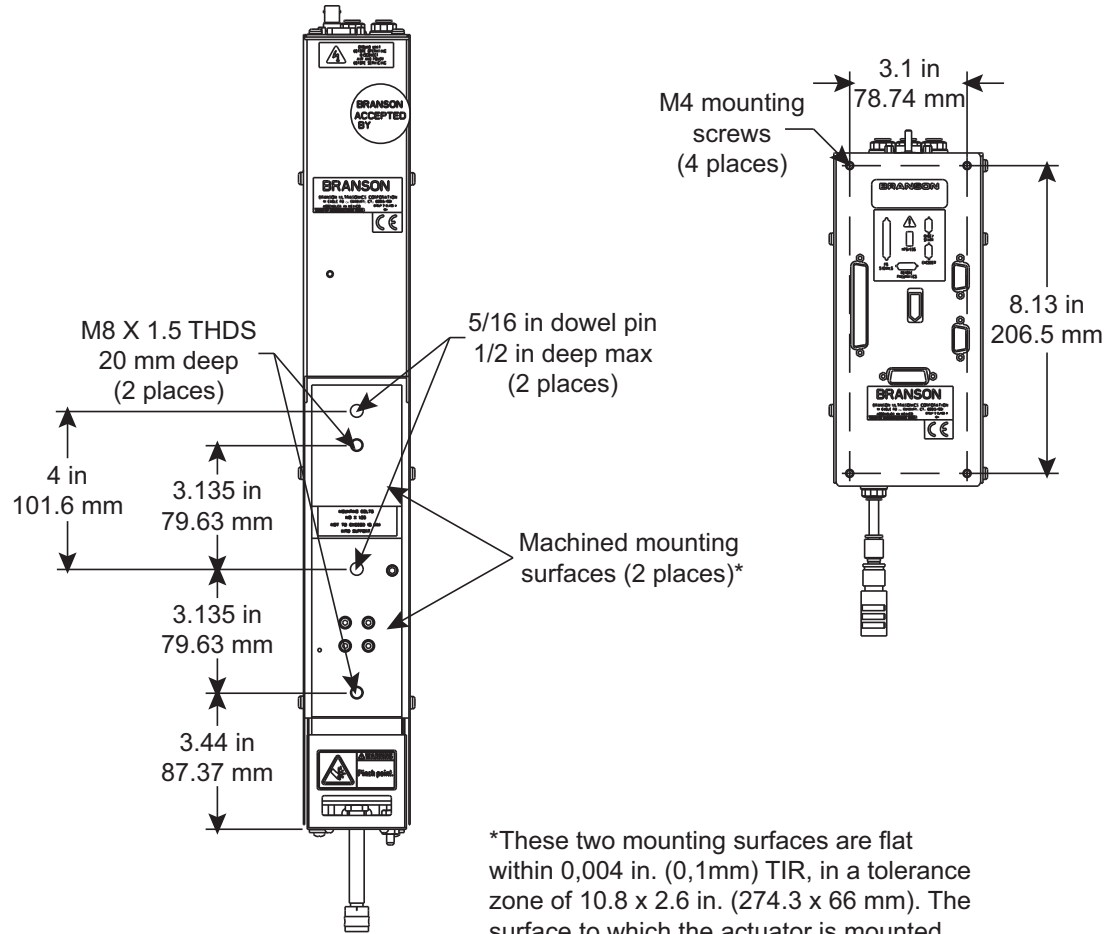

\*These two mounting surfaces are flat within 0,004 in. (0,1mm) TIR, in a tolerance zone of 10.8 x 2.6 in. (274.3 x 66 mm). The surface to which the actuator is mounted must also have the same flatness tolerance

4. Lift the Actuator assembly into position on your mount, and secure using the metric bolts provided.

CAUTION	General Warning
	<p>In the event you must use bolts of a different length, ensure that the bolts extend more than 0.25 inch (6 mm) into the threads in the Actuator housing, but less than 0.62 inch (15 mm).</p>

5. Mount your Interface Box using four M4 screws (nit provided with the Actuator). An optional Interface Box mounting kit is available (kit 101-063-889). The kit consists of a mounting plate and four M4 screws. See [Figure 5.6 Interface Box Mounting Plate \(optional\)](#).

**Figure 5.6** Interface Box Mounting Plate (optional)

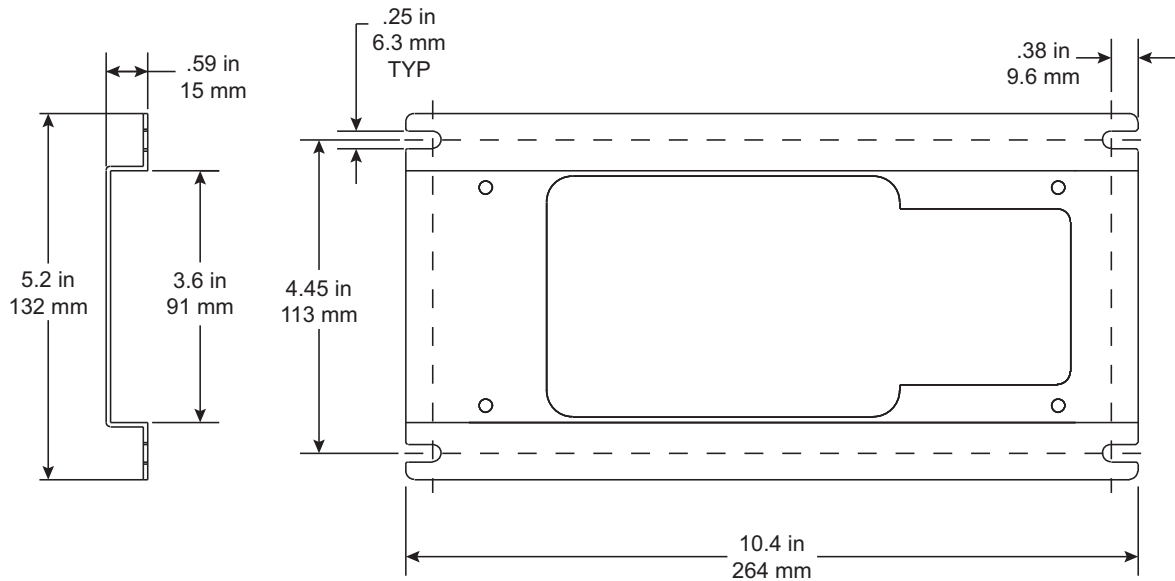

6. Make all pneumatic and electrical connections between the Actuator and Interface Box.

CAUTION	General Warning
	<p>Tubing Connections and Control Cables between the Actuator and Interface Box should be bound together as a bundle with cable ties to secure the airlines.</p>

## 5.5.1 Installing the Mechanical Stop

The mechanical stop limits the downward travel of the horn. To prevent equipment damage, install and adjust the stop so that the horn will not contact your fixture when no workpiece is in place.

To install the mechanical stop using the locking nut:

1. Using a 1/2 in wrench, hold through the locking nut inside the mechanical stop guard opening (See [Figure 5.7 Mechanical Stop Installations and Adjustment](#))
2. Screw the mechanical stop, through the locking nut, into the Actuator
3. Adjust the mechanical stop, as described in Section [6.2.6 Mechanical Stop](#)
4. Tighten the locking nut

CAUTION	General Warning
	<p>If the Mechanical Stop locking nut is not tightened it may prevent the carriage from returning to the home position.</p>



To install the mechanical stop using the set screws:

1. Screw the mechanical stop into the Actuator
2. Adjust the mechanical stop, as described in [6.2.6 Mechanical Stop](#)
3. Use an M3 Hex key to insert the set screws and secure the mechanical stop

**Figure 5.7** Mechanical Stop Installations and Adjustment

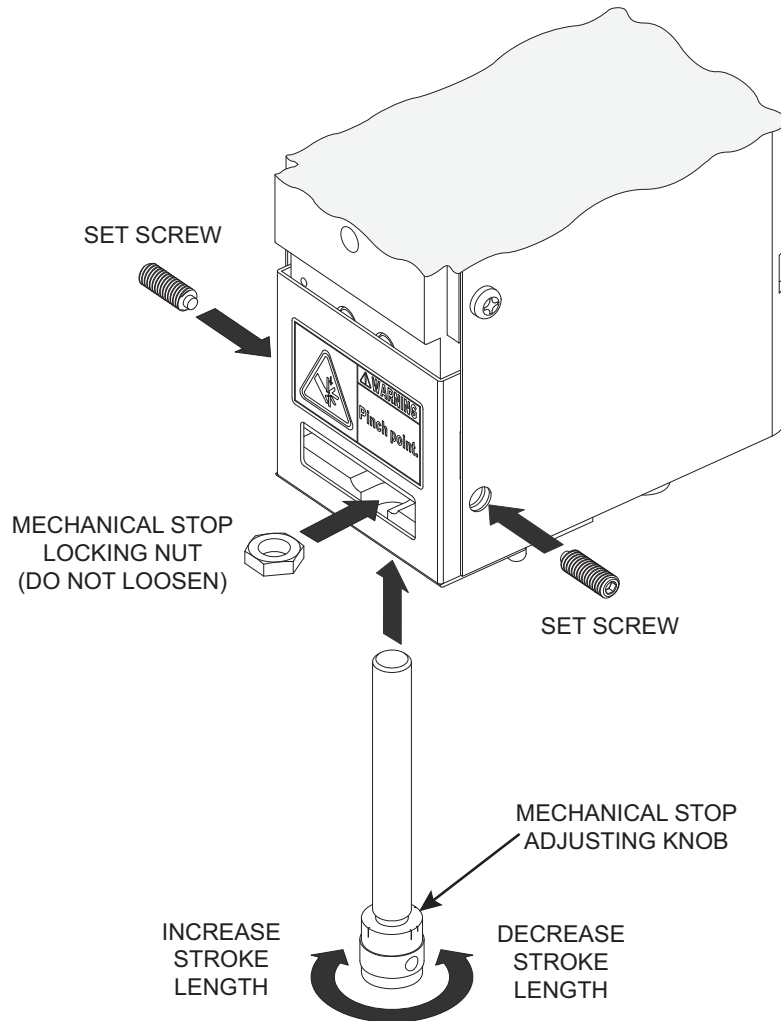

### 5.5.2 Mount the Power Supply

The Power Supply is designated to be placed on a workbench (rubber feet on bottom) within cable-length limits of the Actuator, or it may be rack-mounted in a standard 19 - inch Rack (using an optional rack mount handle kit). It has two rear - mounted fans which draw cooling air from rear to front, which must be free from obstruction. Do not place the Power Supply on the floor or in other locations that will allow dust, dirt or contaminants to be drawn into the Power Supply.

The controls on the front of the Power Supply must be accessible and readable for setup changes.

All electrical connections are made to rear of the Power Supply, which should be positioned in your workspace with adequate clearance (approximately 4 inches or more on either side, and 6 inches to the rear) for cable access and ventilation. Do not place anything on top of the Power Supply case.

In the event the system is to be installed in a high dust environment, the use of a fan filter kit (101-063-614) is required.

See [Figure 5.2 Power Supply Dimensional Drawing](#) for a dimensional drawing of the 2000Xd Power Supply.

**Figure 5.8** Connections on Rear of Power Supply

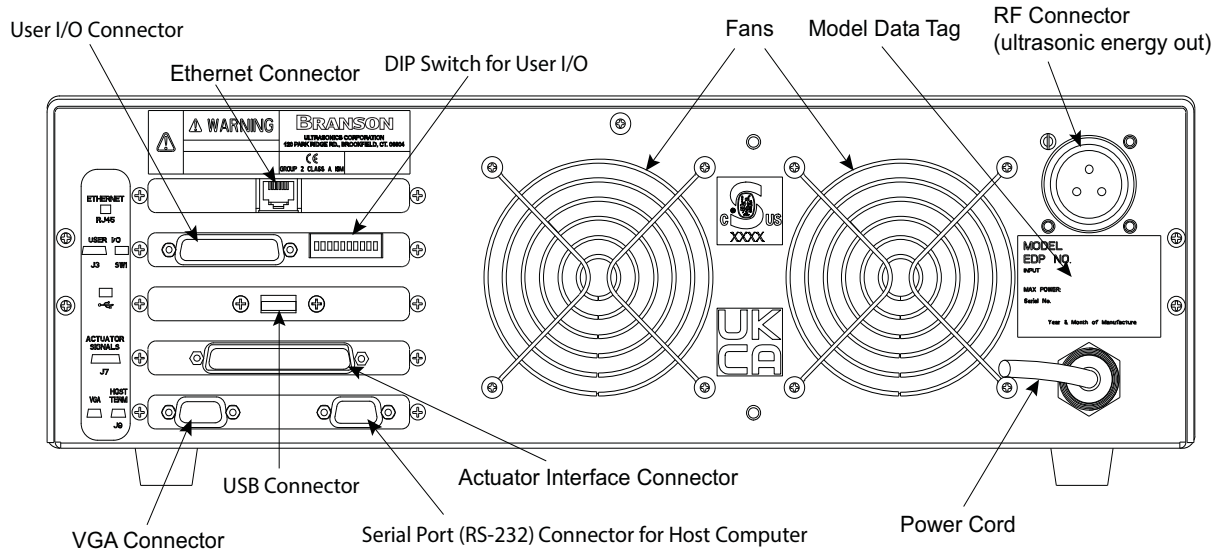

The cable lengths are limited based on the operating frequency of the welding system. Performance and results can suffer if the RF cable is crushed, pinched, damaged or modified. Contact your Branson Representative if you have special cable requirements. In some cases, remote operation from a User I/O or a Remote Terminal can be used to solve a distance limitation.

### 5.5.3 Input Power (Main)

The system requires single-phase input power, which you connect to the Power Supply using the integral power cord. Nominal 120 volt units have a NEMA5-15P plug on the cord, and nominal 200-240 volt units come with a twist-type locking connector, supplied in the box with the Power Supply.

Refer to the unit's Model Data Tag to be sure of the power rating of the Model in your system.

### 5.5.4 Output Power (RF Cable)

Ultrasonic Energy is delivered to a screw-on MS receptacle connection on the rear of the Power Supply, which is connected to the Actuator by an SHV connector.

WARNING	General Warning
	<p>Never operate the System with the RF Cable disconnected or if the RF Cable is damaged.</p>

### 5.5.5 Interconnect between Power Supply, Actuator and Interface Box

The 2000X Micro Actuator and Interface Box have two electrical connections to the Power Supply: The RF Cable and the Actuator Interface cable. A 37-pin Actuator Interface cable is used for Power and Control Signaling between the Power Supply and the Interface Box. The cable connects to the rear of the Power Supply and the rear of the Interface Box. The RF cable is used to deliver RF power to the Actuator. It connects from the rear of the Power Supply to the top of the Actuator.

There are two connections between the interface box and the Actuator: the control cable and the encoder cable. The control cable connects from the top of the Interface Box to the top of the Actuator. The Encoder cable connects from the rear of the Interface Box to the top of the Actuator.

For ground detect use, to have ultrasonic energy turn off when horn comes in contact with your electrically isolated fixture or anvil, it is necessary to install Branson cable EDP No. 100-246-630 from the MPS/GDS receptacle on the rear of the Interface Box to your isolated fixture/anvil in order to utilize this feature.

There can be other connections to the Actuator and Interface Box, and other connections to the Power Supply, but these are the only standard connections, depicted in [Figure 5.9](#).

**Figure 5.9** Electrical Connections from Power Supply to a 2000X Micro Actuator and Interface Box

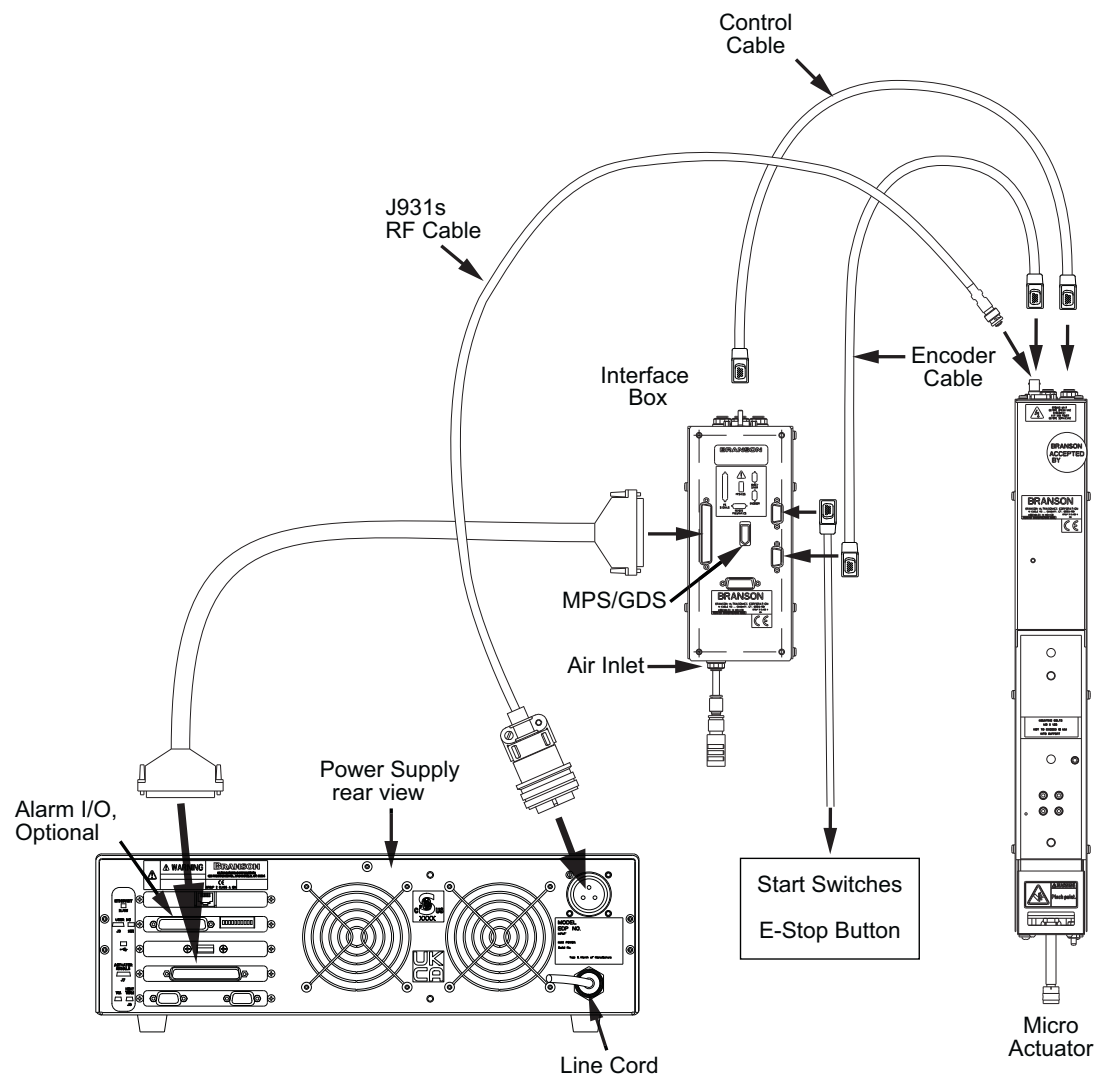

## 5.5.6 Start Switch Connection (Automation)

A Branson actuator requires two start switches and emergency stop connection. For the 2000X Micro Actuator it is required that the user makes his own start switch/E-stop connections, as follows:

**Figure 5.10** Start Switch Connection Codes

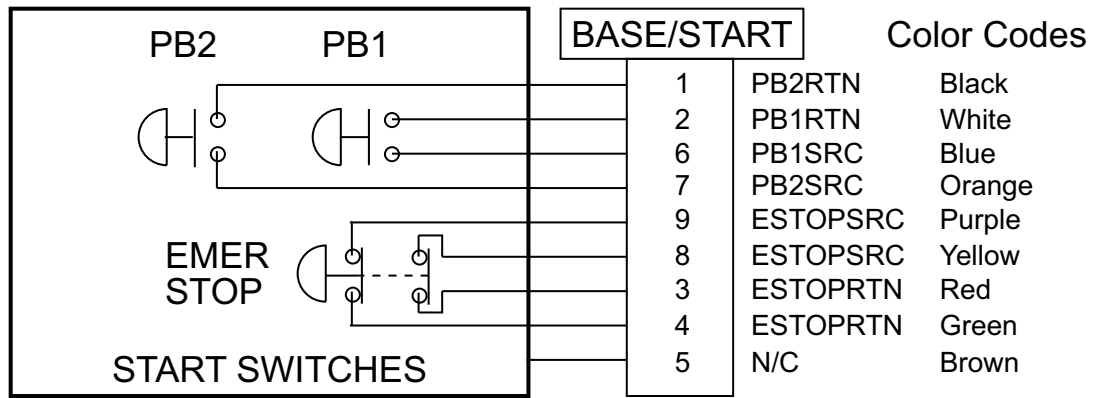

NOTICE	
	<p>Solid State devices may not be used in lieu of mechanical start switches providing their leakage current does not exceed 0.1mA.</p>

NOTICE	
	<p>Start Switches PB1 and PB2 must be closed within 200 milliseconds of each other, and remain closed until the WELD ON signal is active, to effect a start condition.</p>

BASE/START is the DB-9 female connection on the back of the interface box. Your cable requires a male DB-9 (D-shell) connector.

PB1 and PB2 are two normally open start-switches which must be operated simultaneously to start the welding cycle. These must be closed within 200 milliseconds of each other, or error message "Start Sw Time" will display. This doesn't require a reset, but for the next cycle, switches must be within time limit to preclude re-occurrence of error message. Refer to Note above.

EMER STOP is an emergency stop switch, normally closed.

NOTICE	
	<p>Refer to the Branson Automation Guide (EDP 100-214-273) for additional information about selection and use of Input and Output features.</p>

## 5.5.7 Input Power Plug

If you must add or change the input power plug, use the following color code for the conductors found in the international harmonized line cord. Add the plug that is appropriate for your input power receptacle.

CAUTION	General Warning
	<p>The Power Supply can be permanently damaged if it is connected to the incorrect line voltage, or if the wiring connection is mis-wired. It also presents a safety hazard if mis-wired. Use of the correct lug or connector helps prevent incorrect connections.</p>

**Figure 5.11** Line Cord Color Code



WARNING	General Warning
	<p>Unplug the Power Supply (if previously connected) and wait at least two (2) minutes before opening the Power Supply case. Hazardous Voltages exist and are stored in the system.</p>

## 5.6 Safety Equipment

### 5.6.1 Emergency Stop Control

If you use the Emergency Stop signal to terminate a weld, you must clear the Emergency Stop condition. (The welder will not operate until this condition is reset). You must then either press Reset button at the power supply or send an external reset signal to the User I/O connector (J3).

## 5.7 Assembly the Acoustic Stack

CAUTION	General Warning
	<p>The following procedure must be performed by a setup person. If necessary, secure the largest portion of a square or rectangular horn in a soft jawed (brass or aluminum) vise. NEVER attempt to assemble or remove a horn by holding the converter housing or the booster clamp ring in a vise.</p>

CAUTION	General Warning
	<p>Do not use Mylar washers on 40 kHz stacks. Use only silicon grease. This prevents fretting corrosion at the mating interfaces and ensures good thermal conductivity along the stack.</p>

**Table 5.7** Tools

Tool	EDP Number
40 kHz Torque Wrench	101-063-618
40 kHz Spanner Wrench	201-118-024
Silicone Grease	101-053-002

### 5.7.1 Assembling the 40 kHz Acoustic Stack

(Shown with Rectangular Horn Secured in the Vise)

**Table 5.8** Assembling the 40 kHz Acoustic Stack

Step	Action
1	Clean the mating surfaces of the converter, booster, and horn. Remove any foreign material from the threaded holes.
2	Apply a drop of Loctite 290 threadlocker (or equivalent) to the studs for the booster and horn.
3	Install the threaded stud into the top of the booster; torque to 70 in - lbs, 7.9 N·m, and let cure for 30 minutes.
4	Install the threaded stud into the top of the horn; torque to 70 in - lbs, 7.9 N·m, and let cure for 30 minutes.
5	Coat each interface surface with a thin film of silicon grease - <i>but do not apply silicon grease to a threaded stud or tip.</i>
6	Screw the converter to the booster.
7	Torque to 95 in-lbs, 70.7 N·m.

**Table 5.8** Assembling the 40 kHz Acoustic Stack

Step	Action
8	Screw the booster onto the horn.
9	Repeat step 7.

**Figure 5.12** Assembling the 40 kHz Acoustic Stack

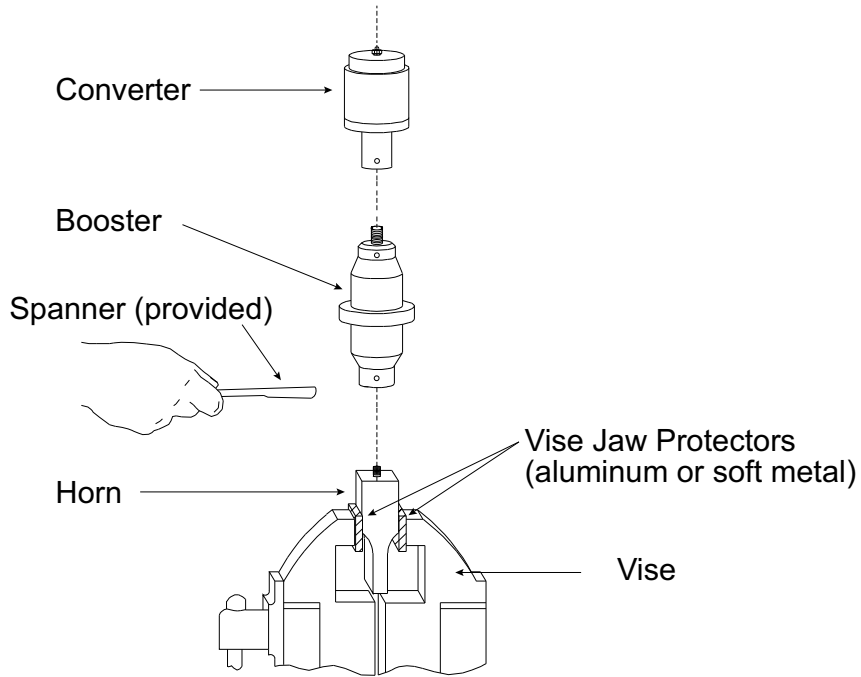

## Stack Assembly Torque Table

NOTICE	
	<p>The use of a Branson torque wrench or the equivalent is recommended. P/N 101-063-618 for 40 kHz systems.</p>

**Table 5.9** Stud Torque Values

Used On	Stud Size	Torque	EDP #
40 kHz	M8 x 1.25	70 in·lbs, 7.90 N·m	100-098-790



## NOTICE



Add a drop of Loctite® 290 threadlocker to the stud. Torque and let cure for 30 minutes before use.

### 5.7.2 Connecting Tip to Horn

1. Clean the mating surfaces of the horn and tip. Remove foreign matter from the threaded stud and hole
2. Hand assemble the tip to the horn. Assemble dry. Do not use any silicone grease
3. Use the spanner wrench and an open-end wrench (refer to [Figure 5.13](#)) and tighten to the tip torque specifications in [Table 5.10 Tip to Horn Torque Specifications](#)

**Figure 5.13** Connecting Tip to Horn

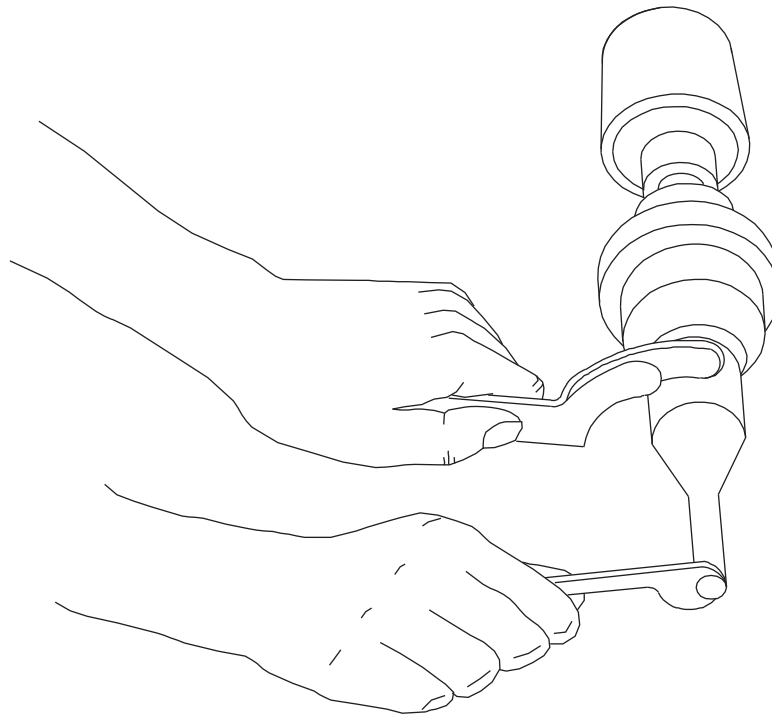

**Table 5.10** Tip to Horn Torque Specifications

Tip Thread	Torque
1/4 - 28	110 in-lbs, 12.42 N·m
3/8 - 24	180 in-lbs, 20.33 N·m

## 5.7.3 Installing the Stack in the Actuator

The ultrasonic stack must first be assembled. To install the stack:

1. Make sure that the system power is turned off by disconnecting the power plug
2. Loosen the four carriage door screws

**Figure 5.14** Installing the 40 kHz Stack in the 2000X Micro Actuator

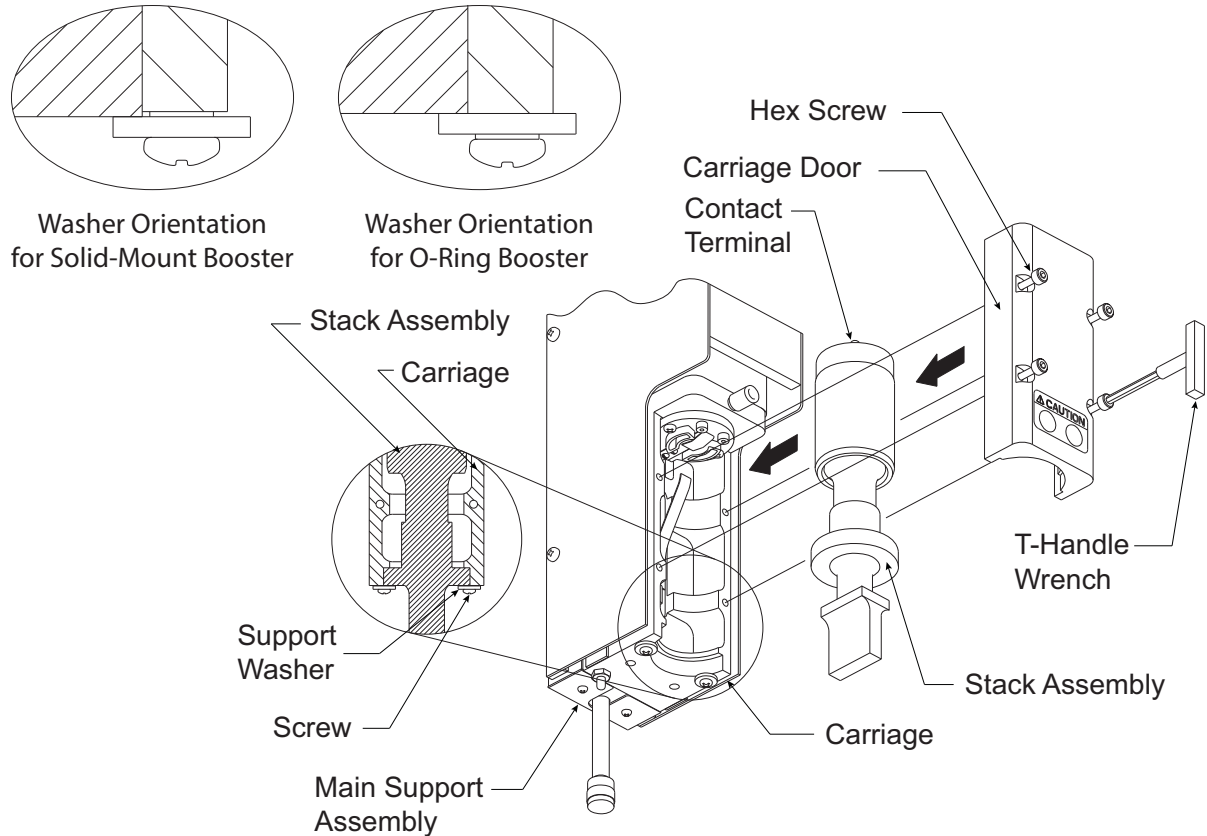

3. Pull the door straight off and set it aside
4. Take the assembled stack and align the ring nut on the booster just above the support washer in the carriage. Firmly push the stack assembly into place, with the acorn nut on top of the converter making contact with the contactor in the tip of the carriage

NOTICE	
	<p>Depending on your booster type, the step washers on the bottom of the carriage may need to be reversed. See <a href="#">Figure 5.14 Installing the 40 kHz Stack in the 2000X Micro Actuator</a> for proper orientation of the step washer.</p>

5. Reinstall the door assembly, and start the four door screws
6. Align the horn by rotating it, if necessary. Torque the carriage door to 20 in-lbs to secure the stack

## 5.8 Testing the Installation

1. Turn on the air supply connections with the air pressure regulator set at minimum values, and verify that the system has air pressure
2. Ensure there are no leaks in the air supply connections
3. Turn on the power supply. The power supply will begin its normal self-check
4. If the power supply displays an alarm message, find the alarm message definition, cause and correction in [Chapter 7: Maintenance](#) of the power supply manual
5. Press the Test button
6. If the Power Supply displays an alarm message at this point, find the alarm message definition in the Maintenance section of [Chapter 7: Maintenance](#) of the Power Supply manual. If there are no alarm messages displayed, go on to the next step
7. Fit a test part onto the fixture
8. Press the Horn Down key and then press and hold the two start switches. The horn will descend to the fixture on the base of the actuator. This verifies specifically that the pneumatic system is working
9. Press the Horn Down key again. The horn will retract. The system should now be functional and can be set up for your application

In summary, if the Power Supply does not display an alarm message and the Actuator descends and retracts correctly, your ultrasonic welder is ready for operation.

**Figure 5.15** Normal Front Panel Display After Power-Up

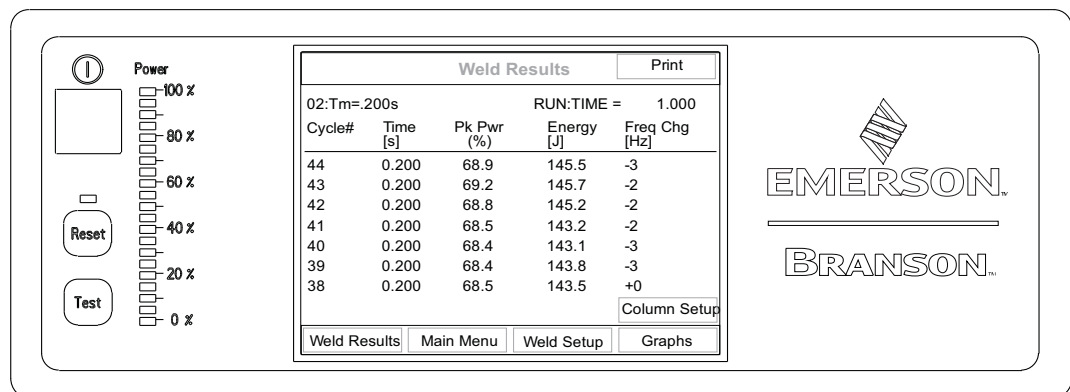

### NOTICE



It is recommended that the customer performs a risk assessment of the welding system installation to ensure safe operation.

## 5.9 Still Need Help?

Branson is pleased that you chose our product and we are here for you! If you need parts or technical assistance with your 2000X-series system, call your local Branson representative or contact the Branson facility in Brookfield, Connecticut U.S.A. by calling (203) 796-0400. Please refer to [Table 1.5 Branson Contacts](#) on [Chapter 1: Safety and Support](#) for a list of Branson key contacts.

---

## Chapter 6: Operation

---

<b>6.1</b>	<b>Actuator Controls . . . . .</b>	<b>68</b>
<b>6.2</b>	<b>Initial Actuator Settings . . . . .</b>	<b>69</b>
<b>6.3</b>	<b>Operating the Actuator . . . . .</b>	<b>74</b>

## 6.1 Actuator Controls

This section describes how to operate a weld cycle using the 2000X Micro Actuator. For more detailed information on making and altering settings, refer to your 2000X-series Power supply manual.

WARNING	General Warning
	<p>When setting up and operating the Actuator, observe the following precautions:</p> <ul style="list-style-type: none"> <li>• Keep hands away from under the horn. Down force (pressure) and ultrasonic vibrations can cause injury</li> </ul>

CAUTION	Loud Noise Hazard
	<p>Plastic parts can vibrate within the audible frequency range when welded. If this occurs, use hearing protectors to prevent possible injury. Do not allow the ultrasonically activated horn to touch a metal base or metal fixture.</p>

The 2000X Micro Actuator and Interface box are controlled by the Power Supply. The Actuator and Interface Box send operating cycle data (such as velocity and force), status information, and alarm information to the Power Supply. The Power Supply sends operating parameters to the Interface Box, determining how and when weld cycles are initiated and terminated. The Actuator and Interface Box continuously pass distance, force and pressure information to the Power Supply while in Setup mode. Refer to your 2000X-series Power Supply manual for tuning, testing, setup, and operating instructions.

WARNING	General Warning
	<p>When using larger horns, avoid situations where fingers could be pinched between the horn and the fixture.</p>

## 6.2 Initial Actuator Settings

The Actuator and Interface Box are controlled by the Power Supply, however there are several functions that are part of the Actuator and Interface Box. These include:

- Factory Air Source
- Regulated Air Pressure and Air Pressure Gauge (located on the Interface Box)
- Downspeed Control (located on the Interface Box)
- Mechanical Stop
- Actuator Position and Height above fixture (Horn travel)
- Emergency Stop (provided as a User I/O signal for automation)

Each of these will affect the operation of the Actuator.

### 6.2.1 Regulated Air Pressure and Air Pressure Gauge

When factory air is present, it is delivered to the regulator located in the Interface Box. The regulator has a locking nut that can be used to prevent undesired changes in your air pressure settings.

Initially, set the Regulator knob to a counter-clockwise position, which is a low pressure setting. In the event something is incorrectly connected, a low air pressure setting will reduce any sudden movement. A typical initial setting is approximately 20-25 psi for a new or unproven setup.

CAUTION	General Warning
	<p>Permanent damage to the system and possible injury can result if the Actuator is supplied with factory air above the maximum gauge reading of 100 psig (690 kPa). Set the pressure regulator to zero before connecting or disconnecting the factory air supply.</p>

### 6.2.2 Factory Air Source

Factory air must be turned on, supplying the Actuator's air pressure regulator with air pressure. If factory air is too low (below 35 psi maintained) the Actuator will not weld or operate reliably. Factory air is also used to provide cooling air to the converter.

Factory air input may affect weld results for applications requiring more weld pressure buildup.

NOTICE	
	<p>Factory Air pressure must be greater than the maximum system requirements. The compressed air system must have sufficient capacity to serve all of the systems connected to it. The use of an accumulator may be required to provide continuous air flow.</p>

CAUTION	General Warning
	<p>Cooling air (80 SCHF) must be supplied to the converter through the air inlet located at the front of the Actuator. Permanent damage to the converter may result if air supply is not provided.</p>

### 6.2.3 Downspeed Control

The Downspeed Control regulates the horn velocity. If the Downspeed control is closed, the actuator will not extend.

NOTICE	
	<p>Be sure to set the down speed control to a slow setting, between 5 and 15, for an initial setup. The downspeed control knob has a set-screw locking mechanism that can be used if desired.</p>

### 6.2.4 Actuator Alignment and Height (Horn travel)

The horn carriage will travel up and down on the Actuator's slides. The distance between the fixture and horn should allow easy and ready access and removal of your parts.

NOTICE	
	<p>Minimum stroke cannot be less than 1/4".</p>

Consistent weld results are best obtained when the horn travel is more than 1/4 inch, because a short distance weld can be affected by other components of the welding system and the pressure build-up on the parts.

### 6.2.5 USB

The two USB ports available on the 2000X power supply are USB 2.0 compliant, allowing complete plug and play, and hot attach/detach for up to 127 external devices. USB 2.0 is fully backward compatible with USB 1.1, supporting speeds of 1.5, 12 and 480 Mbps. For example, keyboard and mouse can be used with USB port at low speed, while printer and USB memory stick will run at High-speed. Information can be transferred to a PC using the Branson History Utility to view and process information. This can be useful when weld



history data requirements exceed the maximum of 50 weld history data that can be stored in the power supply. To download data and graphs, a memory stick must be inserted into the USB port (or hub). Then activate the communication through the touch screen Main Menu:

- Enter the System Configuration menu. Located on the first screen is the USB DATA button
- Once in this menu, you need to switch the USB to On
- Select the weld data or graphs you would like to download. When selecting these, the user has the option of either downloading after a weld cycle (and at what interval, i.e., 1, 5, 20, 100, etc.) and/or when an alarm takes place

The storage capacity of the memory stick will determine the number of cycles and graphs the stick can hold. The data space required for each weld cycle is: 1.0 KB for weld data and 1.35KB for each graph.

NOTICE	
	<p>It is important to remember to turn off the USB feature prior to removing the memory stick; an alarm will be generated if the stick is simply removed.</p>

To view the stored data on a PC you may use Branson's history utility program History.exe (See the following section for further information).

### 6.2.6 Mechanical Stop

The Mechanical Stop affects the amount of downward travel the Actuator is allowed to have, up to the full stroke length of the unit. the multi-turn knurled knob behind the Stack, on the bottom of the Actuator, is the Mechanical Stop adjustment. The Mechanical Stop knob is graduated to represent the stroke adjustment per turn. the adjustment is 0.025 inch (0.635 mm) per turn.

The Mechanical Stop is designed to stop the horn from contacting your Fixture in the event your part is missing. It is not a precision measuring device, and it is usually *not recommended* that this be used as a 'collapse' or other distance weld limiting device. The "missing part" function can also be used to control critical horn to fixture distances.

Initially, set the mechanical stop to allow at least 1/4 inch of horn travel, but any distance up to the full stroke length is suitable.

## To adjust the Mechanical Stop

**Table 6.1** To adjust the Mechanical Stop

Step	Action
1	Remove the factory air from the system or activate the manual dump valve (if installed) and manually lower the carriage until the horn is just above the fixture.
2	<p>If the horn does not reach the fixture and has not travelled 1.75 inches (44.4 mm), loosen the set screws and/or locking nut fully and turn the mechanical stop-adjusting knob counter-clockwise until the carriage reaches the desired position.</p> <p>If the horn reaches the desired position before contacting the stop, turn the adjusting knob clockwise until the stop contacts the carriage.</p>
3	Check the height of the horn and make any necessary adjustments to the stop.
4	When you have reached the setting you want, tighten the set screws and/or locking nut. The set screws and/or locking nut will prevent the mechanical stop adjustment from vibrating loose during operation.
5	Place a part in the fixture, reset the air pressure, and perform a test weld.
6	Check that full force develops between the horn and the part. If not, readjust the mechanical stop.

CAUTION	General Warning
	<p>If the Mechanical Stop locking nut is not tightened it may prevent the carriage from returning to the home position.</p>

Figure 6.1 Mechanical Stop Installation and Adjustment



### 6.2.7 Emergency Stop

The Emergency Stop is a user control that will prevent the Actuator from running, and will also immediately terminate a weld cycle and cause the Horn to retract. It does not remove power from the system. The controls can be configured to provide a beep sound when the emergency stop is engaged. The front panel display of the power supply will indicate that the system is in emergency stop mode when it is.

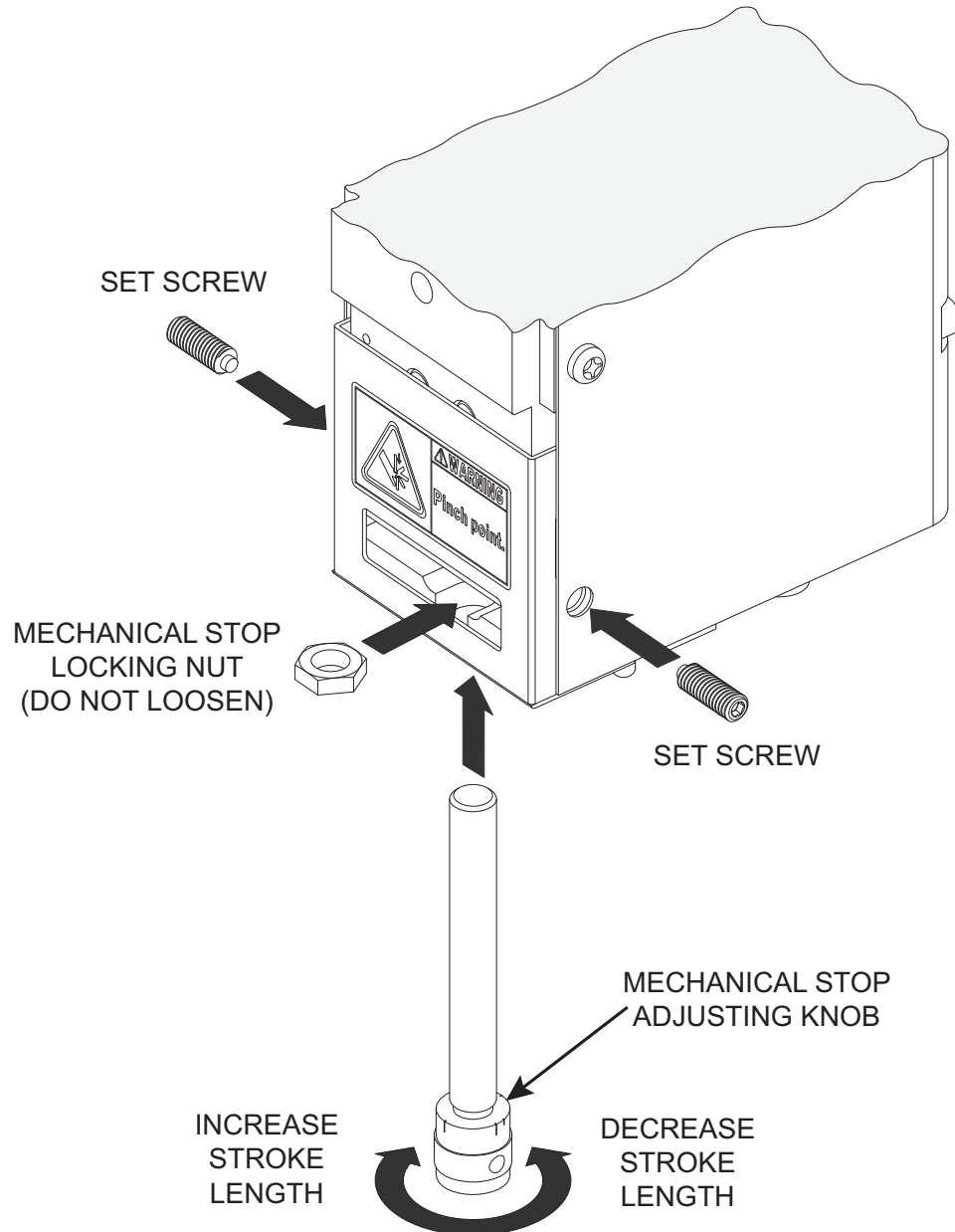
## 6.3 Operating the Actuator

For detailed information about 2000X Micro Actuator controls, see [2.4 Controls and Indicators](#).

**Table 6.2** To Operate the 2000X Micro Actuator

Step	Action
1	If your application has been analyzed in the Branson Applications Laboratory, consult the Branson Lab Report for appropriate settings or check the 2000X distance Power Supply manual.
2	Properly adjust the mechanical stop so that the horn does not make contact with your fixture. See <a href="#">6.2.6 Mechanical Stop</a> for more information.
3	Verify that the Emergency Stop signal source is not in the Emergency Stop mode.
4	With a part in place, supply and hold the start signal, or depress and hold both start switches simultaneously.
5	The horn advances and contracts the part.
6	Force develops between the horn and the part, activating the load cell.
7	Ultrasonic vibrations are activated. The power bag graph on the Power Supply indicates loading (usually in the 25% to 100% range). The start signal / start switches can now be released.
8	Ultrasonics stop and the horn continues to clamp the part for the hold time you selected.
9	After the completion of the hold cycle, the horn retracts automatically and you can remove the part from the fixture.
10	Weld a few parts using the initial parameters and check for the desired properties.

If you do not obtain optimal results initially, based on the quality of the weld obtained and the loading meter reading, you can alter settings to achieve satisfactory results. Change one setting at a time until a weld is produced in minimum time with maximum strength.

---

## Chapter 7: Maintenance

---

<b>7.1</b>	<b>Calibration . . . . .</b>	<b>76</b>
<b>7.2</b>	<b>Periodic and Preventive Maintenance . . . . .</b>	<b>77</b>
<b>7.3</b>	<b>Parts Lists . . . . .</b>	<b>81</b>

## 7.1 Calibration

This product does not require scheduled calibration. However, if you are operating under requirements that mandate periodic calibration, for example, the FDA's Good Manufacturing Practices, contact your Branson representative for additional information.

NOTICE	
	The Actuator and Interface Box are a matched set, and must be kept together. They must not be interchanged with other micro systems.

## 7.2 Periodic and Preventive Maintenance

The following preventive measures will help ensure long term operation of your Branson 2000 Series Actuators.

### 7.2.1 Periodically Clean the Equipment

Periodically disconnect the unit from power, remove the cover and vacuum out any accumulated dust and debris. Remove material adhering to the circuit boards, cooling intake vents and exhaust ports. Periodically disconnect the airline from the air supply, open the air filter and clean the element and bowl with mild soap and water. External covers may be cleaned with a damp sponge or cloth using a solution. Do not allow cleaning solution to enter the unit. Exposed steel surfaces, such as handles, and hardware may require a very light film of oil, such as WD-40, to prevent rust in areas of high humidity.

### 7.2.2 Recondition the Stack (converter, booster, and horn)

Stack components function with greatest efficiency when the mating interface surfaces are in proper condition. Stacks used with silicone grease, as with all 40 kHz products, should be periodically reconditioned to eliminate fretting corrosion. We recommend that a stack using silicone grease be inspected every two weeks for corrosion. the inspection interval can then be adjusted longer or shorter as required, when experience is gained for specific stacks. See the Branson instruction manual for correct stack interface reconditioning procedures.

NOTICE	
	<p>The operating efficiency of the equipment will be greatly affected if the mating interfaces of the converter, booster, and horn are not flat, make poor contact with each other or become corroded. A poor contact condition wastes power and makes tuning difficult. It may also affect the noise level and damage the converter.</p>

#### To recondition the interfaces:

1. Remove the stack from the Actuator
2. Disassemble the converter, booster, and horn stack. Observe the following rules: In the event that you must disassemble a Stack, always use the correct spanner wrench and a suitable soft-faced vise to remove a horn or booster, and reverse the procedures described earlier in this Section

CAUTION	General Warning
	<p>NEVER attempt to remove a horn or booster by holding the converter housing or booster clamp in a vise.</p>

NOTICE	
	Use a soft-jawed vise (brass or aluminum) to remove square or rectangular horns, or horns otherwise unremovable, by reversing the procedure detailed in <a href="#">5.7 Assembly the Acoustic Stack</a> .

3. Wipe the interfaces with a clean cloth or paper towel
4. Examine all interfaces. If any interface is corroded or shows a dark, hard deposit, it should be reconditioned
5. If the interfaces appear to be in good condition, go to step 13
6. If necessary, remove the coupling studs
7. Tape a clean sheet of #400 grit (or finer) emery cloth to a clean, smooth flat surface. A piece of glass is suitable
8. Hold the part to be conditioned at its lower end and carefully stroke it in one direction across the emery cloth. Do not press down. The weight of the component provides enough pressure
9. Perform a second stroke. Rotate the part 1/3 around and stroke it twice across the cloth

NOTICE	
	Use no more than two strokes in one position. Use the same number of strokes at each location.

10. Turn the part remaining 1/3 and repeat
11. Re-examine the interface and repeat steps 8, 9 and 10 until the surface appears clean and smooth. This should not take more than 2 or 3 complete rotations of the part being reconditioned
12. Clean the threaded hole, using a clean cloth or paper towel
13. Replace the stud with a new one if removed. Torque the 3/8-24 studs to 290 in·lbs (32.77 N·m). Torque 1/2-20 studs to 450 in·lbs (50.84 N·m). Torque M8x1/4 studs to 70 in·lb (7.9 N·m)

NOTICE	
	The use of a Branson torque wrench or the equivalent is recommended. P/N 101-063-618 for 40 kHz systems.



CAUTION	General Warning
	Failure to follow torque specifications may cause the stud to loosen or break, and the system to overload. The use of a Branson torque wrench or equivalent is required.

14. Reassemble the stack and install it in the Actuator, using the procedures in [5.7 Assembly the Acoustic Stack](#).

## 7.2.3 Routine Component Replacement

The lifetime of certain parts is based on the number of cycles the unit has completed, or on hours of operation. [Table 7.1 Component Replacements Based on Cycles Run](#) lists the average number of hours or cycles one should use in determining when components should be replaced. Ambient operating temperature also affects lifetime. Higher temperatures reduce the number of cycles and hours before replacement is suggested. The charts below are for equipment operating at a temperature of 72° F to 75° F (22° C - 24° C).

The lifetime of system pneumatic components is influenced by the quality of the compressed air provided. All Branson systems require clean, dry, (normal) factory compressed air. When oil or moisture is present in the compressed air, the lifetime of the pneumatic components will be reduced. This table lists pneumatic parts with an average factory compressed air condition.

NOTICE	
	<p>Actuators running at 5/8" stroke or less should be run at a longer stroke periodically, if possible, to ensure the bearing block grease is distributed within the bearing blocks.</p>

**Table 7.1** Component Replacements Based on Cycles Run

Cycles	Component
At 10 Million Cycles	Hydraulic Snubber
	Air Cylinder
At 20 Million Cycles	Solenoid Valve
	Pressure Regulator
	S-Beam Load Cell Assembly
	Encoder Assembly
	Bearing Slide

For Reference Purposes:

1. A system operating at 60 welds per minute, 8 hours per day, 5 days per week, 50 weeks per year completes approximately 7.2 million cycles in 2000 hours
2. The same system at 24 hours per day, 5 days per week, in 50 weeks completes 21.6 million cycles in 6000 hours
3. 24 hours per day, 365 days per year produces 31.5 million cycles in 8760 hours

Please note that parts replaced during preventive maintenance constitute normal wear and tear. They are not covered by warranty.

## 7.3 Parts Lists

The following tables lists the available Accessories ([Table 7.2 Accessories List for 2000X Micro Actuator](#)) and Parts ([Table 7.3 Spare Parts List for the 2000X Micro Actuator](#)) for the 2000X Micro Actuator:

### 7.3.1 Accessories

**Table 7.2** Accessories List for 2000X Micro Actuator

Description	EDP #
2000X Micro Actuator with 40 mm cylinder	101-134-290E
Converter 4TJ	101-135-041R
<b>Boosters - 40 kHz (Same as XL: 8 mm)</b>	
Black (Ti), Ratio 1:2.5	101-149-084
Silver (Ti), Ratio 1:2.0	101-149-083
Gold (Ti), Ratio 1:1.5	101-149-086
Green (Ti), Ratio 1:1	101-149-085
Black (Al), Ratio 1:2.5	101-149-082
Silver (Al), Ratio 1:2.0	101-149-081R
Gold (Al), Ratio 1:1.5	101-149-080
Green (Al), Ratio 1:1	101-149-079
Purple (Al), Ratio 1:0.6	101-149-087
<b>Solid Mount Boosters - 40 kHz (Same as XL: 8 mm)</b>	
Black (Ti), Ratio 1:2.5	109-041-174
Silver (Ti), Ratio 1:2.0	109-041-175
Gold (Ti), Ratio 1:1.5	109-041-176
Green (Ti), Ratio 1:1.0	109-041-177
Purple (Ti), Ratio 1:0.6	109-041-178

### 7.3.2 Spare Parts

**Table 7.3** Spare Parts List for the 2000X Micro Actuator

Description	EDP #
Micro Linear Encoder Assembly	BU-1036907
RF Harness Assembly	100-246-1382

**Table 7.3** Spare Parts List for the 2000X Micro Actuator

Description	EDP #
RF Contact Block Assembly	149-246-1132
S-Beam Load Cell Assembly	100-246-1456
Solenoid Valve Assembly	100-246-1440
Flow Control Assembly (Down Speed)	100-246-1273
Control Harness, Interface Box	100-246-1457
Control Harness, Actuator	100-246-1458
Interface Board Assembly	102-242-943R
ULS Cable Assembly	100-246-1372
Cable, Control	100-240-365
Cable, Encoder	100-240-364
Power Light Harness Assembly	100-246-924
Carriage 2000X Micro Actuator	100-018-046
Assembly Cylinder 2000X Micro actuator 40 mm Diameter	149-246-1183
Carriage Door (Metal)	100-037-041
Carriage Door Screw	100-298-279
Cover 2000X Micro Actuator	100-032-466
Rod Mech Stop	100-089-067
LED Green Power	200-221-014R
Pressure Indicator	100-246-903
Encoder Indicator Glass Scale	BU-1036908
Mech Stop Set Screw	200-298-302
Mech Stop Lock Nut	109-073-213
Spring Carriage	100-095-162
Assembly Regulator, Precision, Viton	149-246-1240
Assy Gauge	100-246-554
Ground Spring	100-095-024
RF Connector	200-029-808R
Slide Bearing	109-003-085
Contact Block Spring	100-095-161

### 7.3.3 Suggested Spares

**Table 7.4** Suggested Spares

Assembly	EDP #	1 - 4 Units	6 - 12 Units	14+ Units
Air Cylinder	149-246-1183	0	1	1
Carriage	100-018-046	0	0	0
Carriage Door	100-037-041	0	0	0
Carriage Door Screw	100-298-279	0	0	0
Contact Block	149-246-1132	0	1	1
Contact Block, Spring	100-095-161	0	0	0
Down Speed Control	100-246-1373	0	1	1
Gauge	100-246-554	0	1	1
Ground Spring	100-095-024	0	0	0
Interface Board	101-063-948	0	0	1
Linear Encoder	BU-1036907	0	1	1
Glass Encoder	BU-1036908	0	1	1
Load Cell Assembly	100-246-1456	0	0	1
Mech Stop	100-089-067	0	0	0
Power on LED	200-221-014R	0	0	0
Regulator	149-246-1240	0	1	1
Carriage Return Spring	100-095-162	0	1	1
RF Connector	200-029-808R	0	0	1
RF Harness	100-246-1382	0	0	0
Slide Bearing	109-003-085	0	0	0
Solenoid Valve	100-246-1440	0	1	2
ULS Switch	100-246-1372	0	0	0
Pressure Indicator	100-246-903	0	0	0



---

# Index

---

**A**

actuator 43  
afterburst 20  
amplitude stepping 20  
audible 5  
autotuning 20

**B**

booster 23

**C**

cables 45  
cfm 50  
clearance 55  
color code 59  
control limits 20  
converter 23

**D**

defects 8  
discharge 5  
downspeed 19

**E**

electrical input 49  
electrical shock 5  
emergency stop 59  
emissions 7  
encoder 21  
environmental specification 46

**F**

factory air 50  
follow-through 19

**G**

general precautions 5  
guards 7

**H**

hand assemble 63  
hazard 3  
hearing protectors 6  
horn 24  
horn test diagnostics 20  
humidity. 77

## I

- installation 42
- installation requirements 46
- interconnect 57
- inventory 45

## L

- locking nut 54

## O

- off position 5
- open-end wrench 63

## P

- personal protective equipment 5
- pneumatic system 40
- power supply 23
- pretrigger 20
- process alarm display 20

## R

- repair 9
- reset button 60

## S

- s-beam 21
- silicone 63
- sound 6
- spanner wrench 63
- startup diagnostics 20
- static protection equipment 6
- stud torque values 62

## T

- technical specifications 38
- terms and conditions 8
- tip to horn 63
- tools 61
- twist-type locking 56

## U

- unpacking 43

## W

- warranty coverage 9
- wattmeter 20