

Fisher™ 1078 Declutchable Manual Actuator

Contents

Introduction	1
Scope of Manual	1
Description	2
Specifications	3
Educational Services	3
Installation	5
Converting An Existing Power Actuator for use with the Fisher 1078 Manual Actuator	6
Installing the Manual Actuator	6
Installing the Manual Actuator on a 1061 Size 30, 40, 60, 68, 80, or 100 and 1052 Size 70	7
Installing the Manual Actuator on a 2052 Size 1, 2, or 3	7
Operation	7
Engaging and Disengaging the Manual Actuator ..	8
Engaging the Manual Actuator	8
Disengaging the Manual Actuator	8
Maintenance	8
Lubrication	9
Parts Ordering	10
Parts List	10
Manual Actuator Assembly	10
Field Mounting Parts	10
For 1061; and 1052 Size 70 Actuators	10

Figure 1. Fisher 1078 Manual Actuator Mounted on a 2052 Size 1 Actuator



X0178

Introduction

Scope of Manual

This instruction manual includes installation, operation, and maintenance information for the Fisher 1078 declutchable manual actuator (figure 1). Refer to separate instruction manuals for instructions covering the power actuator and control valve.



Do not install, operate, or maintain a 1078 declutchable manual actuator without being fully trained and qualified in valve, actuator, and accessory installation, operation, and maintenance. To avoid personal injury or property damage, it is important to carefully read, understand, and follow all the contents of this manual, including all safety cautions and warnings. If you have any questions about these instructions, contact your [Emerson sales office](#) before proceeding.

Table 1. Specifications

<p>Available Configurations</p> <p>Direct and reverse acting; see Handwheel Rotation in this specification table</p> <p>Actuator Sizes</p> <p>See tables 2, 3, and 4</p> <p>Acceptable Coupling Shaft Diameters</p> <p>See tables 2, 3, and 4</p> <p>Power Actuator Compatibility</p> <p>See tables 2, 3, and 4</p> <p>Output Torque</p> <p>See tables 2, 3, and 4</p> <p>Wheel-Rim Force</p> <p>See tables 2, 3, and 4</p> <p>Handwheel Turns Required For Full Rotation</p> <p>See tables 2, 3, and 4</p> <p>Handwheel Rotation</p> <p>Direct Acting Construction: Clockwise handwheel rotation closes the valve (produces clockwise valve shaft rotation)</p> <p>Reverse Acting Construction: Clockwise handwheel rotation closes the valve (produces counterclockwise valve shaft rotation)</p> <p>Decide whether Direct or Reverse Action is required by referring to the appropriate valve or power actuator instruction manual and determining valve rotation.</p>	<p>Maximum Output Rotation</p> <p>90 degrees; limited by travel stops in the power actuator</p> <p>Standard Mounting Positions</p> <p>1052 (size 70)⁽¹⁾: handwheel down (std) or handwheel right-hand or left-hand mount (optional)</p> <p>1061 (sizes 30, 40, 60, 68, 80, and 100)⁽¹⁾: handwheel down (std) or handwheel right-hand or left-hand mount (optional)</p> <p>2052 (sizes 1, 2, and 3)⁽¹⁾: handwheel down (std) or handwheel right-hand or left-hand mount (optional)</p> <p>Approximate Weights without Handwheel</p> <p>Size AAA: 2.7 kg (6 lb) Size AA: 6.8 kg (15 lb) Size A: 9.5 kg (21 lb) Size 2A: 13.6 kg (30 lb) Size 1A: 15.9 kg (35 lb) Size B: 23.1 kg (51 lb) Size C: 29.9 kg (66 lb) Size D: 63.5 kg (140 lb) Size II-FA: 81.6 kg (180 lb)</p> <p>Handwheel Weight</p> <p>6-inch: 1.8 kg (4 lb) 8-inch: 2.3 kg (5 lb) 12-inch: 3.2 kg (7 lb) 16-inch: 6.8 kg (15 lb) 24-inch: 5.4 kg (12 lb) 30-inch: 6.4 kg (14 lb) 36-inch: 7.3 kg (16 lb)</p>
---	---

1. If a positioner is used, the right-hand or left-hand mounting option will be limited to the side away from the positioner.

Description

The 1078 manual actuator, shown in figures 1 and 2, is a declutchable unit for manual operation of control valves and equipment that use power actuators. The 1078 manual actuator mounts directly to Fisher 1052 size 70; 1061 sizes 30, 40, 60, 68, 80, and 100; and to all sizes of 2052 actuators. The 1078 manual actuator can be engaged to allow manual operation of the valve when the power actuator is not in use. It can be disengaged to allow automatic operation of the valve by the power actuator. The mechanism used allows manual actuator engagement at any point of power actuator rotation.

Figure 2. Fisher 1078 Declutchable Manual Actuator Mounted on a 2052 Size 1 Actuator and V300 Valve with FIELDVUE™ DVC6200 Digital Valve Controller



X0177

Specifications

1078 manual actuator specifications are given in table 1. Specifications for a control valve assembly as it comes from the factory appear on a nameplate attached to the power actuator.

Educational Services

Emerson Educational Services
Phone: +1-800-338-8158
E-mail: education@emerson.com
emerson.com/mytraining

Table 2. Fisher 2052 Actuator Size Selection and Specifications for Sizes AAA, A, and C

MANUAL ACTUATOR SIZE	SHAFT SIZE		POWER ACTUATOR		STANDARD HANDWHEEL DIAMETER		MAXIMUM TORQUE		WHEEL-RIM-FORCE				HANDWHEEL TURNS FOR ROTATION	
									For Maximum Torque		For Less Than Maximum Torque		Degrees	
	mm	Inch	Type	Size	mm	Inch	N•m	Lbf•in	N	Pounds	N	Pounds	60	90
AAA (2400 in•lbs)	12.7	1/2	2052	1	203	8	131	1156	144	32	Divide N•m req'd by 0.91	Divide lbf•in req'd by 36	4	6
	14.2x15.9 15.9	9/16x5/8 5/8					211	1866	232	52				
	19.1	3/4					271	2400	298	67				
A (8000 in•lbs)	14.3x15.9 15.9	9/16x5/8 5/8	2052	2	406	16	489	4326	204	45	Divide N•m req'd by 2.4	Divide lbf•in req'd by 96	5.3	8
	19.1	3/4					590	5221	246	54				
	22.2 25.4	7/8 1					818	7241	341	75				
	28.6x31.8 31.8	1-1/8x1-1/4 1-1/4					904	8000	377	83				
C (18000 in•lbs)	19.1	3/4	2052	3	610	24	1338	11842	279	61	Divide N•m req'd by 4.8	Divide lbf•in req'd by 194	9	13.5
	22.2 25.4	7/8 1					1566	13862	326	71				
	28.6x31.8 31.8	1-1/8x1-1/4 1-1/4					2034	18000	424	93				
	38.1	1-1/2												
	39.7x44.5 44.5 50.8	1-9/16x1-3/4 1-3/4 2												

Table 3. Fisher 1052 Actuator Size Selection and Specifications for Sizes 2A, 1A, B, and C

MANUAL ACTUATOR SIZE (max output torque)	SHAFT SIZE		POWER ACTUATOR(1)		GEAR RATIO	HANDWHEEL DIAMETER		MAXIMUM TORQUE(2)		WHEEL-RIM-FORCE				HANDWHEEL TURNS FOR ROTATION	
										For Maximum Torque		For Less Than Maximum Torque		Degrees	
	mm	Inch	Type	Size	mm	Inch	N•m	Lbf•in	N	Pounds	N	Pounds	60	90	
1A (8200 in•lbs)	31.8, 28.6x 31.8	1-1/4, 1-1/8x 1-1/4	1052	70	32:1	610	24	929	8200	378	85	Divide N•m req'd by 2.4	Divide lbf•in req'd by 96	5.3	8
	38.1 31.8x 38.1	1-1/2, 1-1/4x 1-1/2													
	(44.4, 50.8), 39.7 x44.5	(1-3/4, 2), 1-9/16 x1-3/4													
B (12,000 in•lbs)	31.8	1-1/4	1052	70	40:1	610	24	1356	12,000	369	83	Divide N•m req'd by 3.6	Divide lbf•in req'd by 144	6.7	10
	38.1, (44.4, 50.8)	1-1/2, (1-3/4, 2)													
C (18,000 in•lbs)	31.8	1-1/4	1052	70	54:1	610	24	2034	18,000	414	93	Divide N•m req'd by 4.8	Divide lbf•in req'd by 194	9	13.5
	(44.4, 50.8)	(1-3/4, 2)													

1. Field conversion of actuators for F and G mounting adaptations requires installation of new parts.

2. Compare table value with torque requirements of the valve plus the torque required to compress the power actuator spring (from Fisher Catalog 14). Note that dynamic torque of the valve may have a positive or negative effect on total torque required.

Table 4. Fisher 1061 Actuator Size Selection and Specifications for Sizes 2A, 1A, B, C, D, and II-FA

MANUAL ACTUATOR SIZE (max output torque)	SHAFT SIZE		POWER ACTUATOR		GEAR RATIO	HANDWHEEL DIAMETER		MAXIMUM TORQUE ⁽¹⁾		WHEEL-RIM-FORCE				HANDWHEEL TURNS FOR ROTATION			
										For Maximum Torque		For Less Than Maximum Torque		Degrees			
	mm	Inch	Type	Size		mm	Inch	N•m	Lbf•in	N	Pounds	N	Pounds	60	90		
2A (4800 in.lbs)	12.7	1/2	1061	30	34:1	152	6	58	515	89	20	Divide N•m req'd by 0.66	Divide lbf•in req'd by 26	5.7	8.5		
	15.9, 14.3x 9.5	5/8, 9/16x 5/8						138	1225	214	48						
	19.1	3/4 ⁽³⁾						203	8	239	2120	276	62			Divide N•m req'd by 0.86	Divide lbf•in req'd by 34
	(22.2, 25.4)	(7/8, 1)						305	12	467 ⁽⁴⁾	4140 ⁽⁴⁾	360	81			Divide N•m req'd by 1.3	Divide lbf•in req'd by 51
	31.8	1-1/4								541	4800	416	94				
1A (8200 in.lbs)	(22.2, 25.4)	(7/8, 1)	1061	40, 60, 68	32:1	610	24	305	12	467	4140	382	86	Divide N•m req'd by 1.2	Divide lbf•in req'd by 48	5.3	8
	31.8, 28.6x 31/8	1-1/4, 1-1/8x 1-1/4						929	8200	378	85	Divide N•m req'd by 2.4	Divide lbf•in req'd by 96				
	38.1 31.8x 38.1	1-1/2, 1-1/4x 1-1/2															
	(44.4, 50.8), 39.7 x44.5	(1-3/4, 2), 1-9/16 x1-3/4															
B (12,000 in.lbs)	31.8	1-1/4	1061	40, 60, 68	40:1	610	24	1109	9815	308	68	Divide N•m req'd by 3.6	Divide lbf•in req'd by 144	6.7	10		
	38.1, (44.4, 50.8)	1-1/2, (1-3/4, 2)						1356	12,000	377	83						
C (18,000 in.lbs)	31.8	1-1/4	1061	40, 60, 68	54:1	610	24	1109	9815	231	51	Divide N•m req'd by 4.8	Divide lbf•in req'd by 194	9	13.5		
	(44.4, 50.8)	(1-3/4, 2)						2034	18,000	424	93						
D (30,000 in.lbs)	(44.4, 50.8)	(1-3/4, 2)	1061	80, 100	64:1	762	30	2658	23,524	369	82	Divide N•m req'd by 7.2	Divide lbf•in req'd by 287	10.7	16		
	54, 63.5 57.2x 63.5	2-1/8, 2-1/2, 2-1/4x 2-1/2						914	36	3390	30,000	394	87			Divide N•m req'd by 8.6	Divide lbf•in req'd by 345
II-FA (60,000 in.lbs)	54, 63.5	2-1/8, 2-1/2	1061	80, 100	288:1 ⁽²⁾	406	16	6301	55,762	400	90	Divide N•m req'd by 15.7	Divide lbf•in req'd by 619	48	72		

1. Compare table value with torque requirements of the valve plus the torque required to compress the power actuator spring (from Fisher Catalog 14). Note that dynamic torque of the valve may have a positive or negative effect on total torque required.
 2. Has spur gear.
 3. 2A 3/4 inch shaft will also mount on the 1061 size 40, 60, and 68.
 4. Maximum torque of connection between power and manual actuator.

Installation

⚠ WARNING

Always wear protective gloves, clothing, and eyewear when performing any installation operations to avoid personal injury.

Check with your process or safety engineer for any additional measures that must be taken to protect against process media.

If installing into an existing application, also refer to the **WARNING** at the beginning of the Maintenance section in this instruction manual.

The 1078 manual actuator is normally shipped mounted on a power actuator. If the manual actuator has been shipped separately for installation on a power actuator, or if the manual actuator was removed for maintenance, mount the manual actuator by following the instructions presented in this section.

Converting An Existing Power Actuator For Use With The Fisher 1078 Manual Actuator

Field conversion of a power actuator for use with the 1078 manual actuator may require replacement and/or removal of some parts. The procedures which follow apply only to power actuators which were not ordered specifically for use with the 1078 manual actuator. Proceed as appropriate:

Installing the Manual Actuator

⚠ WARNING

Avoid personal injury from sudden release of process pressure or bursting of parts. Before performing any maintenance operations:

- Do not remove the actuator from the valve while the valve is still pressurized.
- Always wear protective gloves, clothing, and eyewear when performing any maintenance operations to avoid personal injury.
- Disconnect any operating lines providing air pressure, electric power, or a control signal to the power actuator. Be sure the actuator cannot suddenly open or close the valve.
- Use bypass valves or completely shut off the process to isolate the valve from process pressure. Relieve process pressure on both sides of the valve. Drain the process media from both sides of the valve.
- Vent the power actuator loading pressure and relieve any actuator spring precompression.
- Use lock-out procedures to be sure that the above measures stay in effect while you work on the equipment.
- The valve packing box may contain process fluids that are pressurized, *even when the valve has been removed from the pipeline*. Process fluids may spray out under pressure when removing the packing hardware or packing rings, or when loosening the packing box pipe plug.
- Check with your process or safety engineer for any additional measures that must be taken to protect against process media.

NOTICE

Undertavel or overtravel of the valve ball or disk, especially at the closed position, may result in poor valve performance and/or damage to the equipment. Make certain that the power actuator travel stops are properly set before installing and adjusting the manual actuator. Refer to the instruction manuals for the valve and the power actuator for information about setting travel stops.

1. Isolate the control valve from the line pressure, release pressure from both sides of the valve body, and drain the process media from both sides of the valve. Also shut off all pressure lines to the power actuator and release all

pressure from the power actuator. Use lock-out procedures to be sure that the above measures stay in effect while you work on the equipment.

2. Make certain that the power actuator travel stops have been properly set according to the caution given above.
3. For spring-return power actuators, allow the power actuator to remain in the position where the spring is relaxed. For double-acting power actuators, apply supply pressure as appropriate to position the valve disk or ball in either the open or closed position.
4. Note whether the valve disk or ball is in the open or closed position.
5. Rotate the handwheel to move the drive sleeve gear and travel indicator to the position that corresponds with the position of the valve disk or ball. For both direct and reverse acting manual actuators, clockwise handwheel rotation sets the manual actuator to the closed position. Counterclockwise handwheel rotation sets the manual actuator to the open position.

Installing the Manual Actuator on a 1061 Size 30, 40, 60, 68, 80, or 100 and 1052 Size 70

For manual actuator installation on 1061 sizes 30, 40, 60, 68, 80, and 100; and 1052 size 70, remove the actuator cover (key 34) and attached parts from 1061 or 1052. Replace with 1078. Most assemblies require installation of a new lever and splined adaptor to complete the installation. When used, the splined adaptor slides inside the new lever and the lever is then clamped onto the splined adaptor. See figure 5.

1. Remove the lever and add a new lever and splined adaptor when needed. See figure 5.

The splined adaptor slides inside the new lever and the lever is then clamped onto the splined adaptor.

2. Disengage the manual actuator.
3. Install the manual actuator.
4. Tighten the cap screws to the final torque value.
5. For double-acting power actuators, be certain the power actuator is equipped with a bypass valve. Operating the handwheel mechanism against the force of differential cylinder pressures will be difficult or impossible.

Installing the Manual Actuator on a 2052 Size 1, 2, or 3

1. Remove the travel scale and travel indicator. They will no longer be required since the 1078 has it's own scale and indicator.
2. Mount the manual actuator on the surface where the travel scale was.
3. Position the manual actuator on the 2052 so that the drive square fits into the quad square spline of the 2052 lever.
4. Bolt the manual actuator onto the 2052.

Operation

After the travel indicator pointer has been adjusted and the control valve assembly installed, the manual actuator is ready for operation.

NOTICE

Applying too much torque to the actuator and valve parts could cause damage to the parts. To avoid such damage, do not exceed the maximum allowable torques listed in table 2, 3, or 4 or any other torque limitation of internal valve parts. Also, do not use wrenches or other devices on the handwheel or handwheel shaft to increase operating force.

If the force required to rotate the handwheel exceeds the wheel-rim force listed in tables 2, 3, and 4, refer to the maintenance procedure.

Engaging and Disengaging the Manual Actuator

Engaging the Manual Actuator

1. Shut off the supply pressure to the power actuator.
2. Pull the ring on the detent mechanism to unlock the lever. Move the lever into the engaged position until it is against the stop pin and locked in position by the detent mechanism. (Note that stop pins are not available on 1078 size II-FA actuators.)
3. If applicable, open the power actuator bypass valve.

Disengaging the Manual Actuator

NOTICE

Disengaging the manual actuator when forces such as spring compression, cylinder pressure, and dynamic torque are present may cause sudden, extreme movement of all control valve components. This can result in damage to equipment and violent disturbance of the process. Before disengaging the manual actuator, take appropriate steps to ensure that the return to automatic operation will not result in an extreme repositioning of control valve components. Procedures to determine approximate system balance are given in the following steps.

1. Before disengaging the manual actuator, approximate system balance should be achieved. The system is in balance when the actual valve ball or disk position is approximately the same as the position requested by the automatic control system. Under balanced system conditions, the manual actuator disengaging lever moves freely without use of excessive force. If after releasing the detent mechanism, the lever does not move freely toward the disengaged position, some system force is causing an imbalance. A forced return to automatic operation under these conditions can cause serious damage to the equipment and violent disturbance of the process.
2. If possible, determine whether the automatic control system is tending to open or close the valve ball or disk, and rotate the handwheel in the appropriate direction until friction in the manual operator is reduced and the lever can be easily moved by hand. As an alternate approach, local manipulation of the supply pressure to the power actuator may bring the set point of the automatic system closer to the actual valve ball or disk position.
3. If a smooth transition from manual to automatic operation cannot be ensured, isolate the valve from the process. Position the manual actuator so that it matches the position of the ball or disk when no supply pressure is applied to the power actuator.
4. Pull the ring on the detent mechanism to unlock the lever. Push the lever into the disengaged position until it is against the stop pin and locked in position by the detent mechanism. (Note that stop pins are not available on 1078 size II-FA actuators.)
5. Close the bypass valve and return supply pressure to the power actuator.

Maintenance

If the force required to rotate the handwheel exceeds the wheel-rim force listed in tables 2, 3, and 4, check for the following conditions:

- Insufficient lubrication,
- Seized actuator parts,

- Excessive pressure drop across the valve body, or
- Obstruction to the valve disk or ball rotation.

If the manual actuator does not seem to control the process fluid, the worm or drive sleeve gear teeth may be broken, the pin (key 3) may be sheared, or the internal power actuator or valve parts may be broken. Purchase a replacement manual actuator if necessary. Refer to the power actuator and valve instruction manuals if power actuator or valve maintenance is needed.

Lubrication

The interior parts of the 1078 manual actuator should be lubricated on a regular schedule with a quality gear lubricant. The interior parts should also be lubricated whenever difficulty in handwheel rotation indicates a need for lubrication.

⚠ WARNING

Avoid personal injury from sudden release of process pressure or uncontrolled movement of parts. Before performing any maintenance operations:

- **Do not remove the actuator from the valve while the valve is still pressurized.**
- **Always wear protective gloves, clothing, and eyewear when performing any maintenance operations to avoid personal injury.**
- **Disconnect any operating lines providing air pressure, electric power, or a control signal to the power actuator. Be sure the actuator cannot suddenly open or close the valve.**
- **Use bypass valves or completely shut off the process to isolate the valve from process pressure. Relieve process pressure from both sides of the valve. Drain the process media from both sides of the valve.**
- **Vent the power actuator loading pressure and relieve any actuator spring precompression.**
- **Use lock-out procedures to be sure that the above measures stay in effect while you work on the equipment.**
- **The valve packing box may contain process fluids that are pressurized, *even when the valve has been removed from the pipeline*. Process fluids may spray out under pressure when removing the packing hardware or packing rings, or when loosening the packing box pipe plug.**
- **Check with your process or safety engineer for any additional measures that must be taken to protect against process media.**

1. Isolate the control valve from the line pressure, release pressure from both sides of the valve body, and drain the process media from both sides of the valve. If using a power actuator, also shut off all pressure lines to the power actuator, release all pressure from the actuator. Use lock-out procedures to be sure that the above measures stay in effect while you work on the equipment.
2. Mark the position of the travel indicator pointer on the indicator dial. The travel indicator pointer must be returned to its original position when assembling the manual actuator. Remove the machine screws and the travel indicator pointer.
3. Remove the manual actuator cover screws.
4. Remove the travel indicator scale and the gearbox cover plate. Coat the worm, the drive sleeve gear teeth, and the bearing surfaces of the gearbox housing and worm with a quality gear lubricant.
5. Install the cover plate and the travel indicator scale on the gearbox.
6. Replace the manual actuator cover screws.

Parts Ordering

When corresponding with your [Emerson sales office](#) indicate the type number and size of the power actuator and the mounting adaptation used. If the manual actuator was shipped separately (not attached to a power actuator), give the serial number of the unit, which is shown on a tag attached to the manual actuator.

For 1052 (size 70), and 1061 (sizes 30, 40, 60, 68, 80, and 100), indicate valve shaft size.

⚠ WARNING

Use only genuine Fisher replacement parts. Components that are not supplied by Emerson should not, under any circumstances, be used in any Fisher valve, because they may void your warranty, might adversely affect the performance of the valve, and could cause personal injury and property damage.

Parts List

Note

Contact your [Emerson sales office](#) or for Part Ordering information.

Manual Actuator Assembly (figures 3 and 4)

Key	Description
1	Actuator
2	Handwheel
3	Pin

Note

A new lever and splined adaptor (figure 5) are needed on most assemblies for field installation of the 1078 onto the 1052 size 70, and 1061 sizes 30, 40, 60, 68, 80, & 100 actuators.

Key	Description
4	Travel Indicator scale
5	Travel Indicator Pointer
6	Machine Screw, steel (2 required)
9	Shaft Adaptor

Field Mounting Parts

For 1061; and 1052 Size 70 Actuators

Note

Most assemblies require installation of a new lever to complete the installation. Contact your Emerson sales office.

Description
Lever

Figure 3. Fisher 1078 Declutchable Manual Actuator, Sizes 2A, 1A, B, C, and D

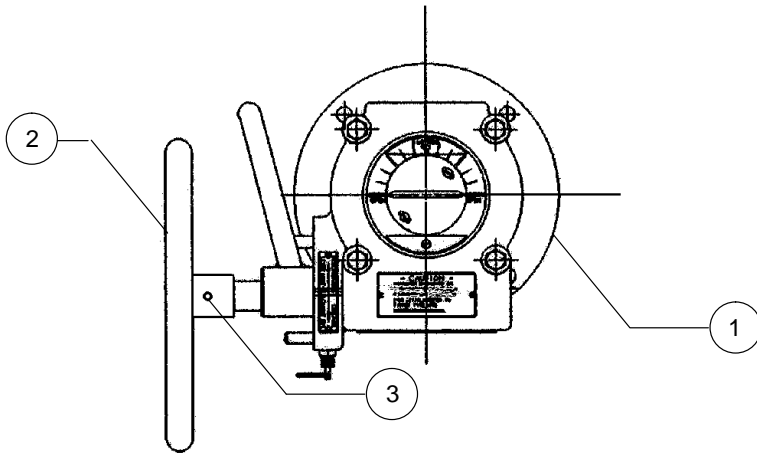

Figure 4. Fisher 1078 Declutchable Manual Actuator, Size II-FA

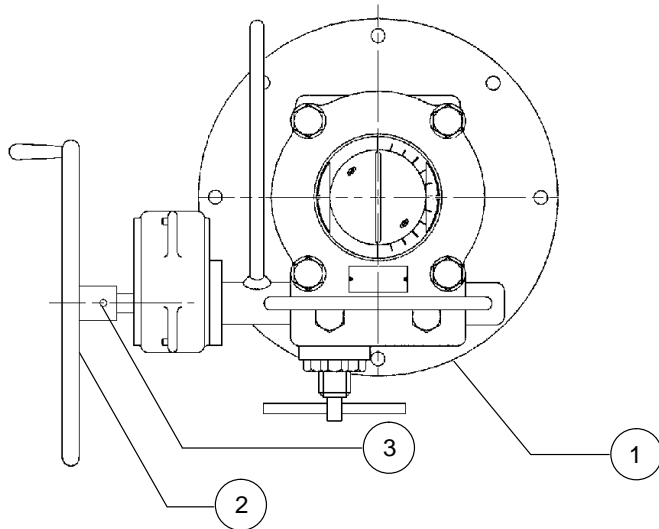
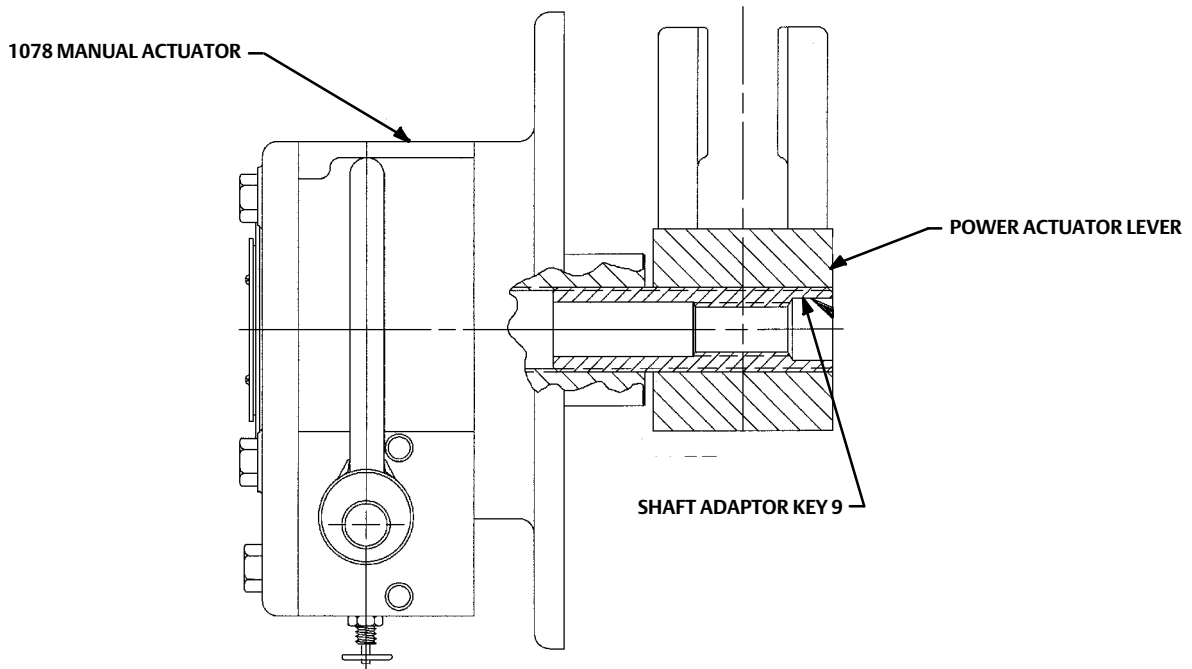

Figure 5. Lever and Splined Adaptor



NOTE:
 PROPER ASSEMBLY OF SHAFT ADAPTOR KEY 9 WHEN REQUIRED
 82458

Neither Emerson, nor any of its affiliated entities assume responsibility for the selection, use or maintenance of any product. Responsibility for proper selection, use, and maintenance of any product remains solely with the purchaser and end user.

Fisher and FIELDVUE are marks owned by one of the companies in the Emerson business unit of Emerson Electric Co. Emerson and the Emerson logo are trademarks and service marks of Emerson Electric Co. All other marks are the property of their respective owners.

The contents of this publication are presented for informational purposes only, and while every effort has been made to ensure their accuracy, they are not to be construed as warranties or guarantees, express or implied, regarding the products or services described herein or their use or applicability. All sales are governed by our terms and conditions, which are available upon request. We reserve the right to modify or improve the designs or specifications of such products at any time without notice.

Emerson
 Marshalltown, Iowa 50158 USA
 Sorocaba, 18087 Brazil
 Cernay 68700 France
 Dubai, United Arab Emirates
 Singapore 128461 Singapore

www.Fisher.com

