

Fisher™ 461 Increased Outlet Angle Sweep-Flo Valve

Contents

Introduction	1
Scope of Manual	1
Description	1
Specifications	2
Educational Services	2
Installation	2
Maintenance	3
Packing Lubrication	4
Packing Maintenance	5
Adding Packing Rings	5
Replacing Packing	5
Replacing Trim	11
Disassembly	11
Assembly	12
Lapping Seating Surfaces	13
Parts Ordering	14
Parts List	14

Figure 1. Fisher 461 Valve with 657 Actuator



W9553-2

Introduction

Scope of Manual



This instruction manual includes installation, maintenance, and parts information for the Fisher 461 anti-choke valve. Refer to separate manuals for instructions covering the actuator, positioner, and accessories.

Description

The 461 valve (figure 1) is a self-cleaning, increased-outlet, angle valve that is typically used in the chemical and hydrocarbon industries where control of residual oils or other liquids with choking properties is necessary. The 461 features a venturi-type throat, which is useful in power plants or slurry services where high pressure drops and flashing might exist.

Do not install, operate, or maintain a 461 valve without being fully trained and qualified in valve, actuator, and accessory installation, operation, and maintenance. To avoid personal injury or property damage, it is important to carefully read, understand, and follow all the contents of this manual, including all safety cautions and warnings. If you have any questions about these instructions, contact your [Emerson sales office](#) before proceeding.

Table 1. Specifications

<p>Valve Sizes (inlet size x outlet size) NPS ■ 2x3, ■ 3x4, ■ 4x6, and ■ 6x8</p> <p>Shutoff Classification per ANSI/FCI 70-2 and IEC 60534-4 Standard: Class IV Optional: Class V</p>	<p>Flow Characteristic Equal percentage Micro-Form flow characteristic in the 12.7 to 31.8 mm (0.5 to 1.25 inch) port size and a modified parabolic flow characteristic in the 38.1 to 114.3 mm (1.5 to 4.5 inch) port size</p> <p>Flow Direction Flow down</p> <p>Packing Arrangement PTFE and graphite ribbon/filament are available as standard packing</p>
---	---

Specifications

Specifications for the 461 valve are shown in table 1. If the valve is shipped with the actuator, some of the valve specifications are on the valve nameplate, which is attached to the actuator. If the valve is shipped without the actuator, the valve nameplate is wired to the valve.

Educational Services

Emerson Automation Solutions
Educational Services - Registration
Phone: 1-800-338-8158
E-mail: education@emerson.com
emerson.com/mytraining

Installation

⚠ WARNING

To avoid personal injury or equipment damage caused by sudden release of pressure, install the valve assembly only where service conditions will not exceed the limits given on the appropriate nameplate.

Always wear protective gloves, clothing, and eyewear when performing any installation operations to avoid personal injury.

Check with your process or safety engineer for any additional measures that must be taken to protect against process media.

If installing into an existing application, also refer to the WARNING at the beginning of the Maintenance section in this instruction manual.

1. Before installing a 461 valve, inspect it for any foreign material that may have collected during crating or shipping.
2. Check that the pipelines are free of pipe scale, chips, welding slag, and other foreign material.
3. Use accepted piping practices when installing the valve.
4. Do not install the valve in a system where the service conditions exceed those specified when the valve was ordered.
5. If continuous operation is required during maintenance and inspection, install a three-valve bypass around the valve body so that it will be isolated.
6. Orient the valve body so that the flow will be in the direction indicated by the flow direction arrow located on the outside of the valve body to ensure proper self-cleaning action.
7. If the actuator and valve are shipped separately, refer to the actuator mounting procedure outlined in the appropriate actuator instruction manual.
8. If the valve body was shipped without packing installed in the packing box, install the packing before putting the valve body into service. Refer to instructions given in the Packing Maintenance procedure.

⚠ WARNING

Personal injury could result from packing leakage. Valve packing was tightened before shipment; however, the packing might require some readjustment to meet specific service conditions.

Valves with ENVIRO-SEAL™ live-loaded packing or HIGH-SEAL Heavy-Duty live-loaded packing will not require this initial re-adjustment. See the instruction manuals titled ENVIRO-SEAL Packing System for Sliding-Stem Valves, [D101642X012](#), or HIGH-SEAL Live-Loaded Packing System, [D101453X012](#), (as appropriate) for packing instructions. If you wish to convert your present packing arrangement to ENVIRO-SEAL packing, refer to the retrofit kits listed in the parts kit sub-section near the end of this manual.

Maintenance

Valve parts are subject to normal wear and must be inspected and replaced as necessary. The frequency of inspection and replacement depends upon the severity of service conditions.

⚠ WARNING

Avoid personal injury or property damage from sudden release of process pressure or bursting of parts. Before performing any maintenance operations:

- Do not remove the actuator from the valve while the valve is still pressurized.
- Always wear protective gloves, clothing, and eyewear when performing any maintenance operations to avoid personal injury.
- Disconnect any operating lines providing air pressure, electric power, or a control signal to the actuator. Be sure the actuator cannot suddenly open or close the valve.
- Use bypass valves or completely shut off the process to isolate the valve from process pressure. Relieve process pressure from both sides of the valve. Drain the process media from both sides of the valve.
- Vent the power actuator loading pressure and relieve any actuator spring precompression.
- Use lock-out procedures to be sure that the above measures stay in effect while you work on the equipment.
- The valve packing box may contain process fluids that are pressurized, *even when the valve has been removed from the pipeline*. Process fluids may spray out under pressure when removing the packing hardware or packing rings, or when loosening the packing box pipe plug.
- Check with your process or safety engineer for any additional measures that must be taken to protect against process media.

Note

If the valve has ENVIRO-SEAL live-loaded packing installed (figure 4), see the instruction manual entitled ENVIRO-SEAL Packing System for Sliding-Stem Valves, [D101642X012](#), for packing instructions.

If the valve has HIGH-SEAL Heavy-Duty live-loaded packing installed (figure 4), see the instruction manual entitled HIGH-SEAL Live-Loaded Packing System, [D101453X012](#), for packing instructions.

Figure 2. Lubricator and Lubricator/Isolating Valve

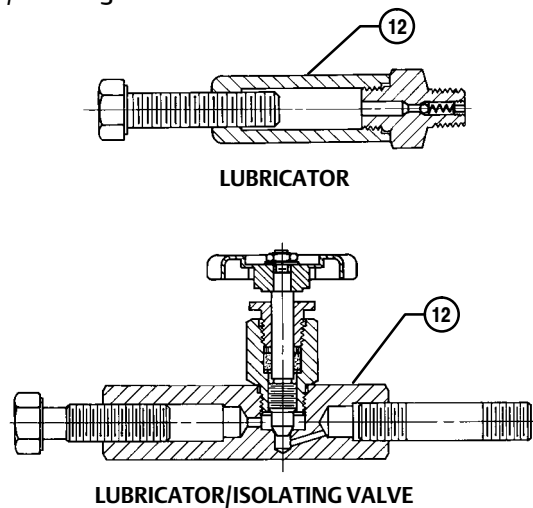

10A9421-A
AJ5428-D
A0832-2

Packing Lubrication

Note

To avoid lubricants breaking down at elevated temperatures, do not lubricate packing used in processes with temperatures over 260°C (500°F).

⚠ WARNING

Do not lubricate parts when used in oxygen service, or where the lubrication is incompatible with the process media. Any use of lubricant can lead to the sudden explosion of media due to the oil/oxygen mixture, causing personal injury or property damage.

If a lubricator or lubricator/isolating valve (figure 2) is provided for PTFE/composition or other packings that require lubrication, it will be installed in place of the pipe plug (key 12, figure 6). Use a good quality silicon-base lubricant. Packing used in oxygen service or in processes with temperatures over 260°C (500°F) should not be lubricated. To operate the lubricator, turn the cap screw clockwise to force the lubricant into the packing box. The lubricator/isolating valve operates the same way except the isolating valve must first be opened and then closed after lubrication is completed.

Packing Maintenance

If there is undesirable packing leakage in the spring-loaded PTFE V-ring packing shown in figure 3, tighten the packing flange nuts (key 25, figure 6) until the shoulder on the packing follower (key 29, figure 6) contacts the bonnet (key 14, figure 6). If leakage continues, replace the packing by following the numbered steps presented in the replacing packing procedure.

If there is undesirable packing leakage with other than spring-loaded PTFE V-ring packing, first try to limit the leakage and establish a stem seal by tightening the packing flange nuts (key 25, figure 6) to at least the minimum recommended torque in table 2 or 3. However, do not exceed the maximum recommended torque in table 2 or 3 or excessive friction may result. If leakage continues, replace the packing by following the numbered steps presented in the Replacing Packing procedure.

If the packing is relatively new and tight on the valve plug stem, and if tightening the packing flange nuts does not stop the leakage, it is possible that the stem is worn or nicked so that a seal cannot be made. The surface finish of a new stem is critical for making a good packing seal. If the leakage comes from the outside diameter of the packing, it is possible that the leakage is caused by nicks or scratches around the packing box wall. While replacing the packing according to the Replacing Packing procedure, inspect the valve plug stem and packing box wall for nicks or scratches.

Adding Packing Rings

Key numbers referred to in this procedure are shown in figure 6, unless otherwise indicated.

When using packing with a lantern ring, it may be possible to add packing rings above the lantern ring as a temporary measure without removing the actuator from the valve body.

1. Isolate the control valve from the line pressure, release pressure from both sides of the valve body, and drain the process media from both sides of the valve. If using a power actuator, also shut off all pressure lines to the power actuator, release all pressure from the actuator. Use lock-out procedures to be sure that the above measures stay in effect while you work on the equipment.
2. Remove the packing flange nuts (key 25) and lift the packing flange, upper wiper, and packing follower (keys 23, 16, and 29) away from the valve body.
3. It may be possible to dig out the old packing rings on top of the lantern ring, but use care to avoid scratching the valve plug stem or packing box wall. Clean all metal parts to remove particles that would prevent the packing from sealing.
4. Remove the stem connector and slip the packing rings over the end of the valve plug stem.
5. Reassemble the packing follower, upper wiper, packing flange, and packing flange nuts (keys 29, 16, 23, and 25).
6. Reconnect the body-actuator stem connection according to the appropriate actuator instruction manual.
7. Tighten the packing flange nuts only far enough to stop leakage under operating conditions. Check for leakage around the packing follower when the valve is being put into service. Retighten the packing flange nuts as required (see table 2 or 3).

Replacing Packing

⚠ WARNING

Refer to the WARNING at the beginning of the Maintenance section in this instruction manual.

Key numbers referred to in this procedure are shown in figure 6, unless otherwise indicated.

1. Isolate the control valve from the line pressure, release pressure from both sides of the valve body, and drain the process media from both sides of the valve. If using a power actuator, also shut off all pressure lines to the power actuator, release all pressure from the actuator. Use lock-out procedures to be sure that the above measures stay in effect while you work on the equipment.
2. Remove the cap screws in the stem connector, and separate the two halves of the stem connector. Then exhaust all actuator pressure, if any was applied, and disconnect the actuator supply and any leakoff piping.

Figure 3. Packing Arrangements

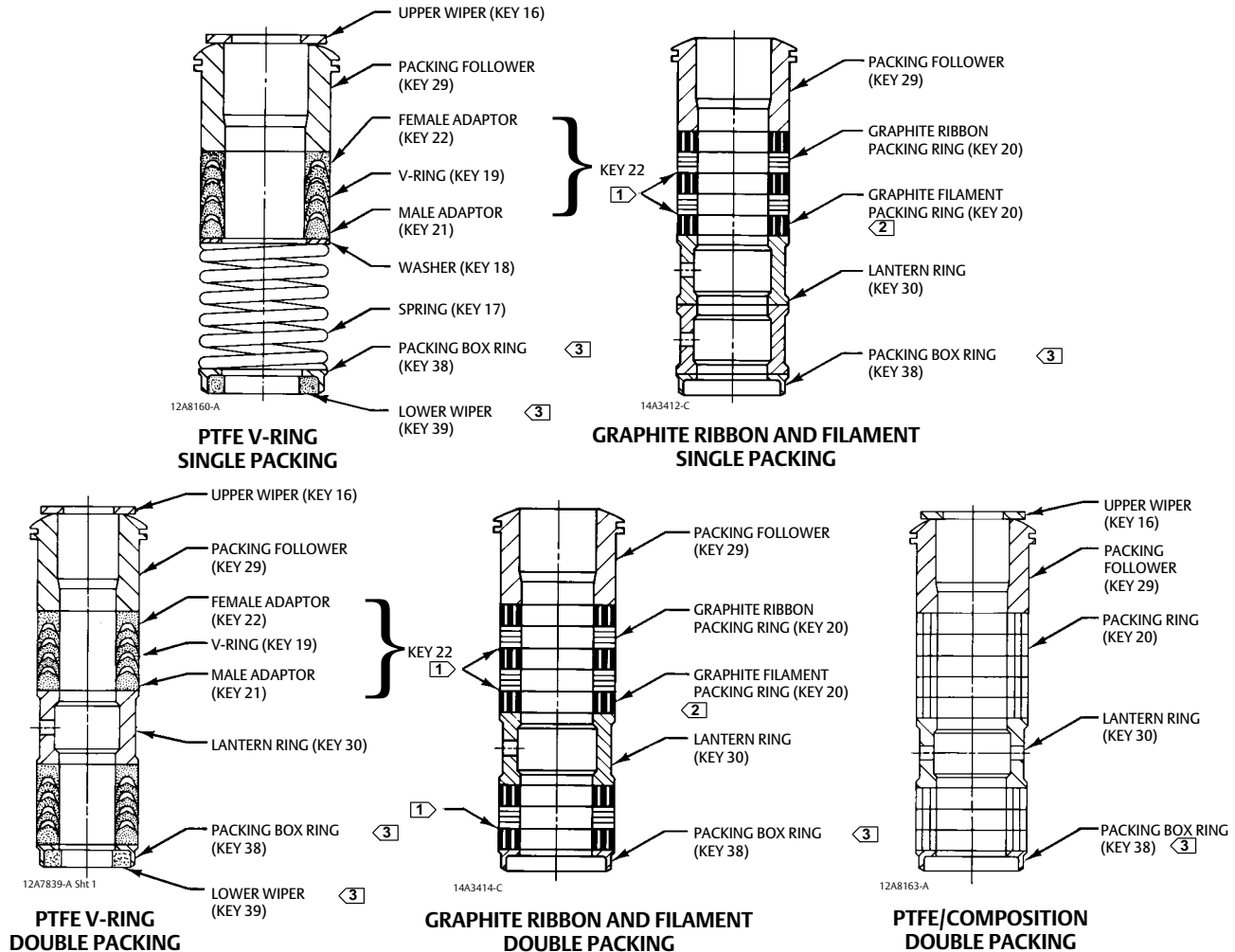

- NOTES:
- ① 0.102 mm (0.004 INCH) THICK SACRIFICIAL ZINC WASHERS. USE ONLY ONE BELOW EACH GRAPHITE RIBBON RING.
 - ② HAS THE APPEARANCE OF A WOVEN OR BRAIDED RING.
 - ③ FOR A FLAT BOTTOM PACKING BOX, THESE PARTS ARE NOT NEEDED.

C0747-1

Figure 4. ENVIRO-SEAL and HIGH-SEAL Packing Systems

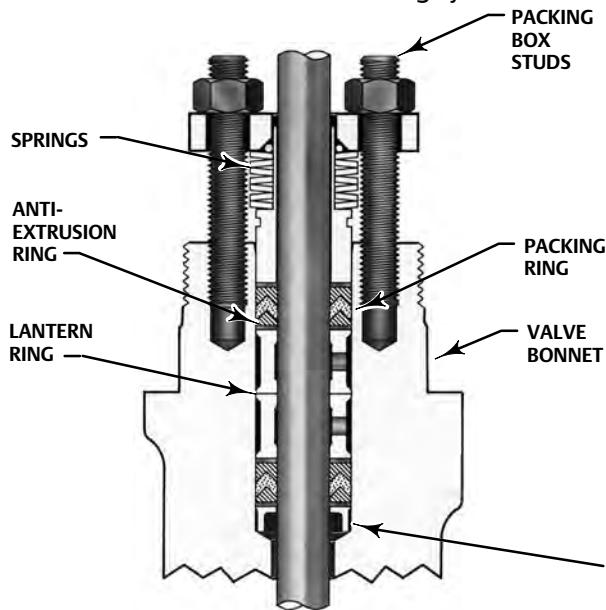

W5803-3

TYPICAL ENVIRO-SEAL PACKING SYSTEM WITH PTFE PACKING

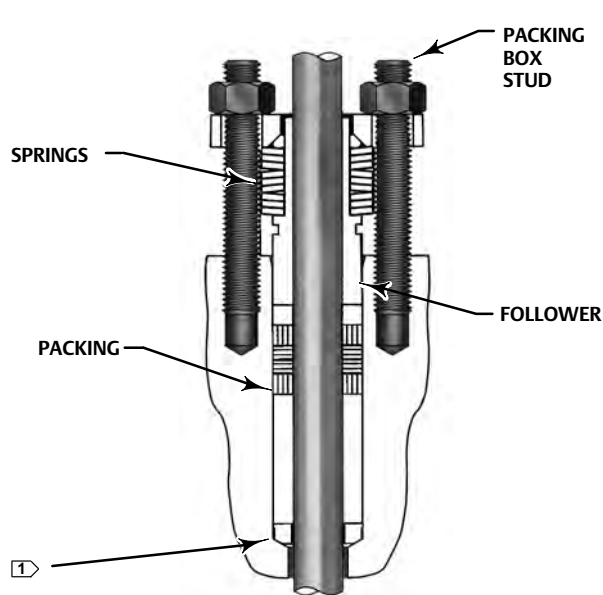

W8532-1

TYPICAL ENVIRO-SEAL PACKING SYSTEM WITH GRAPHITE ULF PACKING

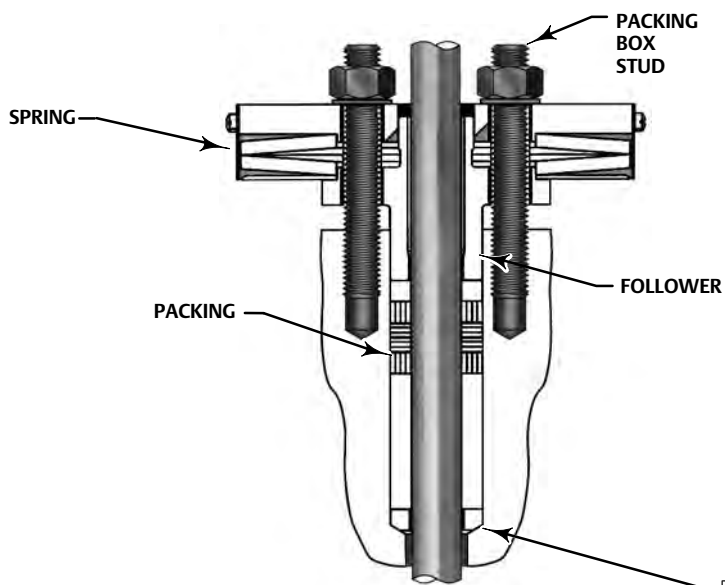

W8533-1

TYPICAL HIGH-SEAL PACKING SYSTEM WITH GRAPHITE ULF PACKING

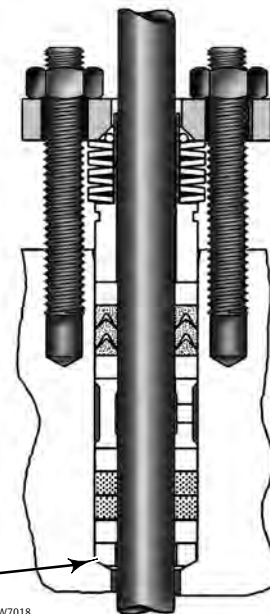

W7018

TYPICAL ENVIRO-SEAL PACKING SYSTEM WITH DUPLEX PACKING

1 FOR A FLAT BOTTOM PACKING BOX, THE PACKING BOX RING AND LOWER WIPER ARE NOT NEEDED.

3. Remove the yoke locknut (key 26), and remove the actuator from the bonnet (key 14).
4. Loosen the packing flange nuts (key 25) so that the packing is not tight on the valve plug stem (key 10). Remove any travel indicator disk and stem locknuts from the valve plug stem threads.

NOTICE

When lifting the bonnet (key 14), be sure that the valve plug and stem assembly (keys 3 and 10) remains on the seat ring (key 2). This avoids damage to the seating surfaces as a result of the assembly dropping from the bonnet after being lifted part way out. The parts are also easier to handle separately. Use care to avoid damaging gasket sealing surfaces.

⚠ WARNING

To avoid personal injury or property damage caused by uncontrolled movement of the bonnet, loosen the bonnet by following the instructions in the next step. Do not remove a stuck bonnet by pulling on it with equipment that can stretch or store energy in any other manner. The sudden release of stored energy can cause uncontrolled movement of the bonnet. If the liner sticks to the bonnet, proceed carefully with bonnet removal and support the liner so that it will not fall unexpectedly from the bonnet.

Note

The following step also provides additional assurance that the valve body fluid pressure has been relieved.

5. Hex nuts (key 8) attach the bonnet to the valve body. Loosen these nuts approximately 3 mm (1/8 inch). Then loosen the body-to-bonnet gasketed joint by either rocking the bonnet or prying between the bonnet and valve body. Work the prying tool around the bonnet until the bonnet loosens. If no fluid leaks from the joint, proceed to the next step.
6. Unscrew the hex nuts (key 8) and carefully lift the bonnet off the valve stem. If the valve plug and stem assembly starts to lift with the bonnet, use a brass or lead hammer on the end of the stem and tap it back down. Set the bonnet on a cardboard or wooden surface to prevent damage to the bonnet gasket surface.
7. Remove the valve plug (key 3), bonnet gasket (key 6) and the liner (key 5).

⚠ WARNING

To avoid personal injury or property damage caused by process media leakage, inspect the liner, bonnet, and body gasket surfaces to ensure they are in good condition, with all foreign material removed. Small burrs less than approximately 0.076 mm (0.003 inches) in height (the thickness of a human hair) can be ignored. Scratches or burrs that run across the serrations are not permitted under any conditions, because they will prevent the gaskets from sealing properly.

8. Clean all gasket surfaces with a good wire brush. Clean in the same direction as the surface serrations, not across them.
9. Cover the opening in the valve body to protect the gasket surface and to prevent foreign material from getting into the valve body cavity.
10. Remove the packing flange nuts (key 25), packing flange (key 23), upper wiper (key 16), and packing follower (key 29). Carefully push out all the remaining packing parts from the valve side of the bonnet using a rounded rod or other tool that will not scratch the packing box wall.

Figure 5. Installing Graphite Ribbon/Filament Packing Rings One at a Time

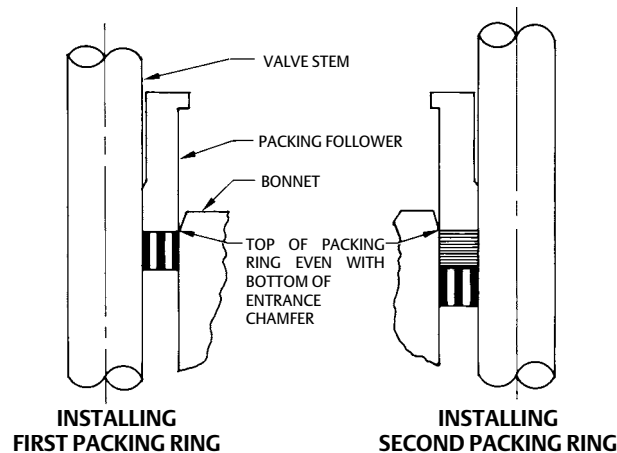

A2207-2

11. Clean the packing box and the following metal packing parts: packing follower, packing box ring, spring or lantern ring, and, for single arrangements of PTFE V-ring packing only, special washer (key 18).
12. Inspect the valve stem threads for any sharp edges that might cut the packing. A whetstone or emery cloth may be used to smooth the threads if necessary.
13. Remove the protective covering from the valve body cavity, and install the liner. Install the plug and position the new bonnet gasket (key 6) on top of the valve body. Then slide the bonnet over the stem and onto the studs (key 7).

Note

The prelubricated hex nuts (key 8) referred to in step 14 can be identified by a black film coating on the nut threads.

The proper bolting procedures in step 14 include--but are not limited to--ensuring that the bonnet stud threads are clean, and that the hex nuts are evenly tightened to the specified torque values.

NOTICE

Failure to comply with good bonnet-to-body bolting practices and the torque values shown in table 4 may result in damage to the valve. Cheater bars or slug wrenches should not be used for this procedure.

Hot torquing is not recommended.

14. Lubricate the stud threads, nut threads, and the faces of the hex nuts (key 8) with anti-seize lubricant (not necessary if new factory prelubricated hex nuts are used). Replace the hex nuts and tighten them finger-tight. Stroke the valve several times to center the trim. Torque the nuts in a crisscross pattern to no more than 1/4 of the nominal torque value specified in table 4.

When all nuts are tightened to that torque value, increase the torque by 1/4 of the specified nominal torque and repeat the crisscross pattern. Repeat this procedure until all nuts are tightened to the specified nominal value. Apply the final torque value again and, if any nut still turns, tighten every nut again.

Note

When installing packing rings, prevent entrapping air between the rings. Add the rings one at a time without forcing them below the chamfer of the packing box entrance chamber. As each successive ring is added, the stack should not be pushed down more than the thickness of the added ring (figure 5).

15. Install new packing and the metal packing box parts according to the appropriate arrangement in figure 3. If desired, packing parts may be pre-lubricated with a silicon base grease for easier installation. Slip a smooth-edged pipe over the valve stem, and gently tamp each soft packing part into the packing box, being sure that air is not trapped between adjacent soft parts.
16. Slide the packing follower, wiper, and packing flange into position. Lubricate the packing flange studs (key 24) and the faces of the packing flange nuts (key 25). Replace the packing flange nuts.

For the spring-loaded PTFE V-ring packing shown in figure 3, tighten the packing flange nuts until the shoulder on the packing follower (key 29) contacts the bonnet.

For graphite packing, tighten the packing flange nuts to the maximum recommended torque shown in table 2. Then, loosen the packing flange nuts, and retighten them to the recommended minimum torque shown in table 2.

For other packing types, tighten the packing flange nuts alternately in small equal increments until one of the nuts reaches the minimum recommended torque shown in table 3. Then, tighten the remaining flange nuts until the packing flange is level and at a 90-degree angle to the valve stem.

For ENVIRO-SEAL or HIGH-SEAL live-loaded packing, refer to the note at the beginning of the Maintenance section.

17. Mount the actuator on the valve body assembly, and reconnect the actuator and valve plug stems according to the procedures in the appropriate actuator instruction manual.

Table 2. Recommended Torque for Graphite Type Packing Flange Nuts (Non Live-Loaded)

VALVE STEM DIAMETER		PRESSURE RATING	TORQUE			
			N•m		lbf•ft	
mm	Inches		Min	Max	Min	Max
19.1	3/4	CL600	21	31	15	23
		CL900	27	41	20	30
		CL1500	34	50	25	37
		CL2500	41	61	30	45
25.4	1	CL600	35	53	26	39
		CL900	42	62	31	46
		CL1500	52	77	38	57
		CL2500	61	91	45	67
31.8	1-1/4	CL600	49	74	36	55
		CL900	56	83	41	61
		CL1500	68	102	50	75
		CL2500	81	122	60	90

Replacing Trim

Refer to figure 6.

Disassembly

1. Remove the actuator and the bonnet according to steps 1 through 6 of the Replacing Packing section.
2. Remove the valve plug and stem assembly (keys 3 and 10) from the valve. If the stem needs to be replaced, drive the pin (key 11) out, and unthread the stem from the plug.

NOTICE

Never use an old stem with a new valve plug. The use of an old stem requires drilling a new pin hole through the stem, which will weaken the stem.

3. If the valve plug needs replacing, replace the entire valve plug and stem assembly. Do not reuse the old stem on a new valve plug. If only a new stem is necessary, screw the plug onto the new stem. Drill a 4.8 mm (3/16 inch) hole through the stem using the plug pin hole as a guide. Drive the pin into the stem and plug.

Table 3. Recommended Torque for PTFE Type Packing Flange Nuts (non live-loaded)

VALVE STEM DIAMETER		PRESSURE RATING	TORQUE			
			N•m		lbf•ft	
mm	Inches		Min	Max	Min	Max
19.1	3/4	CL600	10	15	7	11
		CL900	27	41	20	30
		CL1500	34	50	25	37
		CL2500	41	61	30	45
25.4	1	CL600	17	25	13	18
		CL900	42	62	31	46
		CL1500	52	77	38	57
		CL2500	61	91	45	67
31.8	1-1/4	CL600	24	36	18	27
		CL900	56	83	41	61
		CL1500	68	102	50	75
		CL2500	81	122	60	90

4. With the stem and valve plug assembly removed, slide the liner (key 5) out of the valve body. Inspect the seat ring (key 2) for nicks and scratches. Make sure the valve plug and seat ring contact surfaces are free of nicks and scratches.
5. To remove the liner (key 5), break it loose by using cap screws in the tapped holes located in the liner's flange. (In some very hard materials, i.e., R30006, the holes have been omitted; therefore, a sleeve puller or similar device must be used).
6. To replace the seat ring (key 2), remove the valve from the line, or remove the pipe connected to the flange. Then, unthread the seat ring retainer (key 4), and remove the seat ring through the bottom of the valve body.

Table 4. Recommended Torque for Valve Body to Bonnet Nuts⁽¹⁾

VALVE SIZE, NPS	PRESSURE RATING	STUD DIAMETER, INCHES	TORQUE			
			B7/2H, B7M/2HM, B8M2/8M, S20910, S32760, S66286/Gr.7M		N06625	
			N•m	lbf•ft	N•m	lbf•ft
2x3	CL300	7/8	373	275	339	250
	CL600		373	275	339	250
	CL900		373	275	339	250
	CL1500		373	275	339	250
	CL2500	1-1/8	712	525	712	525
3x4	CL300	7/8	373	275	339	250
	CL600		373	275	339	250
	CL900	1	522	385	502	370
	CL1500		522	385	502	370
	CL2500		1-1/2	1654	1220	1654
4x6	CL300	1	522	385	502	370
	CL600		522	385	502	370
	CL900	1-1/4	942	695	942	695
	CL1500		942	695	942	695
	CL2500		1-3/4	2670	1970	2670
6x8	CL300	1	522	385	502	370
	CL600		522	385	502	370
	CL900	1-1/2	1654	1220	1654	1220
	CL1500		1654	1220	1654	1220

1. Contact your [Emerson sales office](#) for torque requirements when other bolt materials or lubricants other than anti-seize lubricants are used.

Table 5. Recommended Torque for Seat Ring Retainer

VALVE SIZE, NPS	PRESSURE RATING	TORQUE (lbf•ft)
2x3	CL600	1100
	CL1500	1200
	CL2500	
3x4	CL600	2100
	CL1500	
	CL2500	
4x6	CL600	4600
	CL1500	4800
	CL2500	
6x8	CL600	6100
	CL1500	

Assembly

- When assembling, use a new bonnet gasket (key 6), and wipe all sealing surfaces (valve body, bonnet, and gaskets) with a clean cloth. If the seat ring (key 2) was removed, install it in the valve body (key 1), and then torque the seat ring retainer (key 4) into the valve body. Because there is no gasket between the seat ring and the valve body, make sure that the mating surfaces are clean and free of nicks and scratches.
- Replace the liner (key 5). Then, slide the valve plug and stem assembly (keys 3 and 10) into the valve body (key 1).

3. Mount the bonnet (key 14) onto the valve body (key 1), being careful not to damage the gasket.

Note

If the seating surfaces of the valve plug and seat ring require lapping, refer to the Lapping Seating Surfaces section before continuing to assemble the valve.

NOTICE

Avoid product damage in the following step by taking care not to damage the packing while installing the bonnet.

4. If it is necessary to replace the packing, perform steps 10 through 16 of the Replacing Packing section. However, if it is not necessary to replace the packing, make sure to install the bonnet carefully on the valve body to avoid damaging the packing with the valve stem threads.
5. Lubricate the valve body studs and nuts (key 7) with anti-seize lubricant, and install the nuts (key 8) on the bolts. Tighten the nuts in a crisscross pattern to no more than 1/4 of the nominal torque value specified in table 4 to ensure a positive seal and even pressure on the bonnet.

When all nuts are tightened to that torque value, increase the torque by 1/4 of the specified nominal torque and repeat the crisscross pattern. Repeat this procedure until all nuts are tightened to the specified nominal value. Apply the final torque value again and, if any nut still turns, tighten every nut again.

Note

It may be necessary to repeat the bolting pattern several times until the bonnet-to-body seal is made since the tightening of one nut might loosen an adjacent nut. It is recommended that the pattern be repeated until none of the nuts will turn at the recommended torque.

6. Mount the actuator on the bonnet, and make up the stem connection according to the procedure given in the appropriate actuator instruction manual.

Lapping Seating Surfaces

A certain amount of leakage should be expected with metal-to-metal seating in any valve body. If the leakage becomes excessive, however, the condition of the seating surfaces of the valve plug and seat ring can be improved by grinding. Large nicks should be machined out rather than ground out. Use a commercial lapping compound or a mixture of 600-grit Carborundum and solidified vegetable oil. Apply the compound to the bottom of the valve plug, and apply white lead to the seat ring to prevent excessive tearing or cutting during lapping. The white lead should not be mixed with the grinding compound, but rather applied separately.

The valve must be assembled to the extent that the valve plug and stem assembly (keys 3 and 10) and the seat ring (key 2) are in place and the bonnet (key 14) is bolted to the valve body (key 1). A simple handle can be made from a piece of strap iron locked to the valve plug stem with nuts. Rotate the handle alternately in each direction to lap the seats. After lapping, remove the bonnet, and clean the seating surfaces. Completely assemble as described in the Assembly part of the Maintenance section, and test the valve for shutoff. Repeat the lapping procedure if leakage is still excessive.

Parts Ordering

Each body-bonnet assembly is assigned a serial number, which is on the body nameplate. The serial number also appears on the actuator nameplate if you bought a valve and actuator assembly. Refer to this serial number when contacting your [Emerson sales office](#) for technical advice. When ordering replacement parts, mention this serial number. Also specify key number and part description following Parts List.

⚠ WARNING

Use only genuine Fisher replacement parts. Components that are not supplied by Emerson should not, under any circumstances, be used in any Fisher valve, because they may void your warranty, might adversely affect the performance of the valve, and could cause personal injury and property damage.

Parts List

Note

Contact your Emerson sales office for Part Ordering information.

Key Description

1	Valve Body If you need a valve body as a replacement part, order by valve size, serial number, and desired material.
2*	Seat Ring
3*	Plug/Stem Assembly
4*	Seat Ring Retainer
5*	Liner
6*	Gasket
7	Stud Bolt, (8 req'd for NPS 2x3 through NPS 4x6, 12 req'd for NPS 6x8)
8	Hex Nut, (12 req'd for NPS 6x8, 8 req'd for all other sizes)

Key Description

9	Line Position Pin
11	Packing Box Ring
12	Pipe Plug
14	Bonnet If you need a bonnet as a replacement part, order by valve size and stem diameter, serial number, and desired material.
16*	Upper Wiper
17	Spring
18	Washer
19*	Packing Ring
21*	Male Adaptor
22*	Female Adaptor
23	Packing Flange
24	Packing Stud (2 req'd)
25	Packing Nut (2 req'd)
26	Yoke Locknut
29	Packing Follower
33	Companion Flange
34*	Gasket (2 req'd)
35	Stud Bolt (4 req'd)
36	Hex Nut (4 req'd)
37	Equalizing Connection
40	Nameplate
41	Wire
42	Drive Screw
43	Nameplate

Actuator Groups (by Type Number)

Group 1 90 mm (3-9/16 Inch) Yoke Boss	Group 100 & 407 127 mm (5, 5H Inch) Yoke Boss
585C 657 and 667—76.2 mm (3 Inch) Travel 1008 685 785C	585C 657 1008 685 785C
	Group 101 & 404 127 mm (5, 5H Inch) Yoke Boss
	667

Neither Emerson, Emerson Automation Solutions, nor any of their affiliated entities assumes responsibility for the selection, use or maintenance of any product. Responsibility for proper selection, use, and maintenance of any product remains solely with the purchaser and end user.

Fisher and ENVIRO-SEAL are marks owned by one of the companies in the Emerson Automation Solutions business unit of Emerson Electric Co. Emerson Automation Solutions, Emerson, and the Emerson logo are trademarks and service marks of Emerson Electric Co. All other marks are the property of their respective owners.

The contents of this publication are presented for informational purposes only, and while every effort has been made to ensure their accuracy, they are not to be construed as warranties or guarantees, express or implied, regarding the products or services described herein or their use or applicability. All sales are governed by our terms and conditions, which are available upon request. We reserve the right to modify or improve the designs or specifications of such products at any time without notice.

Emerson Automation Solutions
 Marshalltown, Iowa 50158 USA
 Sorocaba, 18087 Brazil
 Cernay, 68700 France
 Dubai, United Arab Emirates
 Singapore 128461 Singapore

www.Fisher.com

