

Fisher™ 585C Series Piston Actuators

Contents

Introduction	1
Scope of Manual	1
Description	2
Specifications	2
Educational Services	2
Principle of Operation	8
Actuator with Handwheel	8
Actuator with Spring Return	10
Installation	10
Bypass Assembly	11
Three-Way Valve Applications Note	11
Actuator Mounting	11
Size 25 and 50 Actuator Mounting	11
Size 60-130 Actuator Mounting	13
Stem Connector Assembly (Size 60-130)	13
585C Handwheels	14
Handwheel Operation (Sizes 25 and 50)	14
Handwheel Operation (Sizes 60-130)	14
Maintenance (Sizes 25 and 50)	15
Replacing Handwheel Housing O-Ring or Thrust Bearings (Sizes 25 and 50)	16
Replacing Seals, Changing Action, or Changing Bias Spring(s) (Sizes 25 and 50)	17
Maintenance (Sizes 60-130)	20
Side-Mounted Handwheel Maintenance (Sizes 60-130)	21
Disassembly of Handwheel Constructions (Sizes 60 and 68)	21

Figure 1. Fisher 585C Series Piston Actuator



Disassembly of Handwheel Constructions (Sizes 80-130)	23
Reassembly (Sizes 60-130)	23
Parts Ordering	24
Parts Kits	25
Parts List	26
Sizes 25 and 50	26
Sizes 60-130	32

Introduction

Scope of Manual

This instruction manual provides information on installation, maintenance, and parts ordering for the Fisher 585C piston actuators. Refer to separate instruction manuals for information about other equipment and accessories used with these actuators.

Information for the 585CLS long stroke actuator can be found in the Fisher 585CLS Instruction Manual ([D103793X012](#)).



Do not install, operate, or maintain a 585C Series actuator without being fully trained and qualified in valve, actuator, and accessory installation, operation, and maintenance. To avoid personal injury or property damage, it is important to carefully read, understand, and follow all the contents of this manual, including all safety cautions and warnings. If you have any questions about these instructions, contact your [Emerson sales office](#) before proceeding.

Description

585C pneumatic piston actuators (figure 1) provide accurate throttling or on-off control of sliding-stem valves. The 585C actuator uses a double-acting cylinder, which requires air pressure for operation.

Size 25 and 50 actuators are available as a springless construction or with a bias spring. Depending on configuration, the bias spring will retract or extend the piston rod upon loss of cylinder air pressure. Size 60 through 130 actuators are available as springless constructions only.

585C actuators are typically supplied with a DVC6200 digital valve controller, or a 3600 P/P or I/P analog positioner. The 585C actuator is available with a top-mounted or side-mounted manual handwheel, depending on actuator size.

Specifications

Specifications for the 585C piston actuators are given in table 1. Some individual actuators come from the factory with specifications stamped on a nameplate attached to the yoke.

Educational Services

Emerson Automation Solutions
Educational Services - Registration
Phone: 1-800-338-8158
E-mail: education@emerson.com
emerson.com/mytraining

Table 1. 585C Specifications (Sizes 25-130)

Operating Pressure⁽¹⁾

Sizes 25-50

Maximum Allowable: 10.3 bar (150 psig)

Minimum Recommended: 1.4 bar (20 psig)

Sizes 60-130

Maximum Allowable: See table 8

Minimum Recommended: 2.4 bar (35 psig)

Travel

See table 2

Thrust Capabilities

See tables 4 through 8

Stroking Speeds

Varies with actuator size, actuator spring, travel, and supply pressure. If stroking speed is critical, consult your [Emerson sales office](#)

Piston Area

See table 2

Cylinder Volumetric Displacement

See table 2

Operative Temperature Limits⁽¹⁾

For All Sizes

Standard Construction

(Nitrile O-Rings): -40 to 80°C (-40 to 175°F)

Optional Construction

(Fluorocarbon O-Rings): -18 to 149°C (0 to 300°F)

For Sizes 60-130

Low Ambient Temperature option:

Fluorosilicone O-Rings: -60 to 80°C (-76 to 175°F)

Yoke Boss and Valve Stem Diameters

See table 3

Pressure Connections

Size 25-60

■ 1/4 NPT internal (standard), or ■ 3/8 NPT internal (optional)

Sizes 68-130

■ 1/2 NPT internal (standard)

Instrument Mounting

Universal NAMUR mounting

Construction Materials

Part	Material
Yoke	Ductile Iron
Piston	Aluminum
Cylinder	Aluminum
Bolting and Fasteners	Steel NCF (std)
	Stainless Steel (std and low ambient)
Springs (sizes 25 and 50 only)	Alloy Steel
O-Rings	Nitrile (std), Fluorocarbon, Fluorosilicone
Actuator Stem	Chrome-plated Steel
Stem Connection	Stainless Steel
Travel Indicator Scale	Stainless Steel
Paint	Polyester Powder
Cylinder Seal Bushings (sizes 60-130 only)	Brass
Stem Connector (sizes 60-130)	Zinc-plated steel (std)
	Stainless Steel (std and low ambient)

Approximate Weights

(less positioner and handwheel)

Size 25

2-1/8 inch yoke boss, 7 kg (16 pounds)

2-13/16 inch yoke boss, 8 kg (17 pounds)

Size 50

2-13/16 inch yoke boss, 20 kg (45 pounds)

3-9/16 inch yoke boss, 22 kg (48 pounds)

Size 60: 31 kg (68 pounds)

Size 68: 54 kg (120 pounds)

Size 80: 102 kg (225 pounds)

Size 100: 113 kg (250 pounds)

Size 130: 188 kg (415 pounds)

Options

Sizes 25 and 50

■ Top-mounted handwheel, see figures 6, 8, and 9 and table 9

■ Cylinder bypass valve ■ Limit switches ■ Fisher 4200 position transmitter

Sizes 60-130

■ Integral side-mounted handwheel, (figure 10)

Sizes 25-130

■ FIELDVUE™ mounting options

■ Fisher 377 trip valve system to fail actuator

■ up or ■ down or ■ lock in last position

■ TopWorx™ DXP M21GNEB electrical valve stem position switch

■ Micro-Switch limit switches

1. The pressure/temperature limits in this manual and any applicable standard or code limitation for valve should not be exceeded.

Table 2. Fisher 585C Piston Cylinder Clearance Volumes

PISTON AT TOP OF CYLINDER (SPRINGS BELOW PISTON FOR SIZE 25 AND 50)								
Actuator Size	Piston Area		Maximum Actuator Travel		Upper Clearance Volume		Volume Below Piston	
	cm ²	Inches ²	cm	Inches	cm ³	Inches ³	cm ³	Inches ³
25	168	26	2.9	1.125	104	6.3	1750	107
50	303	47	5.1	2	330	20	5200	320
60	358	55.5	5.1	2	310	19	2700	163
			10	4	310	19	4400	270
			20	8	310	19	8200	500
68	571	88.5	5.1	2	1230	75	7500	460
			10.2	4	1230	75	7500	460
			20.3	8	1230	75	13300	810
80	571	88.5	10.2	4	1230	75	7500	460
			20.3	8	1230	75	13300	810
100	842	130.5	10.2	4	1700	104	10700	650
			20.3	8	1700	104	19200	1170
130	1430	221.5	10.2	4	4600	280	18500	1130
			20.3	8	4600	280	33000	2000
PISTON AT BOTTOM OF CYLINDER (SPRINGS ABOVE PISTON FOR SIZE 25 AND 50)								
Actuator Size	Piston Area		Maximum Actuator Travel		Lower Clearance Volume		Volume Above Piston	
	cm ²	Inches ²	cm	Inches	cm ³	Inches ³	cm ³	Inches ³
25	168	26	2.9	1.125	77	4.7	1790	109
50	303	47	5.1	2	350	22	5200	320

Table 3. Yoke Boss and Valve Stem Diameters

ACTUATOR SIZE	YOKE BOSS DIAMETER		VALVE STEM DIAMETER	
	mm	Inches	mm	Inches
25	54	2-1/8	9.5	3/8
	71	2-13/16	12.7	1/2
50	71	2-13/16	12.7	1/2
	90	3-9/16	19.1	3/4
60	90	3-9/16	19.1	3/4
68	90	3-9/16	19.1	3/4
80	127	5, 5H	25.4	1
			31.8	1-1/4
100	127	5, 5H	25.4	1
			31.8	1-1/4
130	127	5, 5H	25.4	1
			31.8	1-1/4

1. Heavy actuator to bonnet bolting.

Actuator Thrust Capabilities

Table 4. Fisher 585C Size 25 and 50 Actuator Thrust Capabilities, U.S. Units (spring retracts actuator stem)

ACTUATOR SIZE	SPRING RATE, lb/in	ACTUATOR STEM TRAVEL, INCHES	SPRING THRUST W/ ACTUATOR STEM RETRACTED, POUNDS	SPRING THRUST W/ ACTUATOR STEM EXTENDED, POUNDS	NET THRUST FOR 585C WITH ACTUATOR STEM FULLY EXTENDED AT FULL TRAVEL										SPRINGS USED, BY COLOR	
					Operating Pressure, psig											
					40	50	60	70	80	90	100	110	125	150		
					Force, Pounds											
25	0	All	0	0	1040	1300	1560	1820	2080	2340	2600	2860	3250	3900	Springs Not Used	
	200	0.5625	200	313	730	990	1250	1510	1760	2020	2280	2540	2930	3580	Gold	
		0.75	200	350	690	950	1210	1470	1730	1990	2250	2510	2900	3550		
		0.875	200	375	660	920	1180	1440	1700	1960	2220	2480	2870	3520		
		1.125	200	425	610	870	1130	1390	1650	1910	2170	2430	2820	3470		
	400	0.5625	400	625	410	670	930	1190	1450	1710	1970	2230	2620	3270	Light Green	
0.75		400	700	340	600	860	1120	1380	1640	1900	2160	2550	3200			
0.875		400	750	290	550	810	1070	1330	1590	1850	2110	2500	3150			
500	0.5625	500	781	260	520	780	1040	1300	1560	1820	2080	2460	3110	White		
	0.75	500	875	160	420	680	940	1200	1460	1720	1980	2370	3020			
	0.875	500	938	100	360	620	880	1140	1400	1660	1920	2310	2960			
700	0.5625	700	1094	X	200	460	720	980	1240	1500	1760	2150	2800	Gold & White		
	0.75	700	1225	X	70	330	590	850	1110	1370	1630	2020	2670			
	0.875	700	1313	X	X	250	510	760	1020	1280	1540	1930	2580			
900	0.5625	900	1406	X	X	150	410	670	930	1190	1450	1840	2490	Light Green & White		
	0.75	900	1575	X	X	X	240	500	760	1020	1280	1670	2320			
	0.875	900	1688	X	X	X	130	390	650	910	1170	1560	2210			
50	0	All	0	0	1840	2300	2760	3220	3680	4140	4600	5060	5750	6900	Springs Not Used	
		330	0.75	330	578	1310	1780	2250	2720	3190	3660	4140	4610	5310	6490	Pink
			0.875	330	619	1270	1740	2210	2680	3150	3620	4090	4570	5270	6450	
			1.125	330	701	1180	1660	2130	2600	3070	3540	4010	4480	5190	6370	
			1.5	330	825	1060	1530	2000	2470	2950	3420	3890	4360	5070	6250	
	600	2	330	990	900	1370	1840	2310	2780	3250	3720	4190	4900	6080		
		0.75	600	1050	840	1310	1780	2250	2720	3190	3660	4130	4840	6020	Light Blue	
		0.875	600	1125	760	1230	1700	2170	2650	3120	3590	4060	4770	5950		
		1.125	600	1275	610	1080	1550	2020	2500	2970	3440	3910	4620	5800		
		1.5	600	1500	390	860	1330	1800	2270	2740	3210	3680	4390	5570		
	2	600	1800	90	560	1030	1500	1970	2440	2910	3380	4090	5270			
	930	0.75	930	1628	260	730	1200	1670	2140	2610	3090	3560	4260	5440	Pink & Light Blue	
		0.875	930	1744	140	610	1080	1560	2030	2500	2970	3440	4150	5330		
		1.125	930	1976	X	380	850	1320	1790	2270	2740	3210	3910	5090		
		1.5	930	2325	X	30	500	970	1450	1920	2390	2860	3570	4750		
		2	930	2790	X	X	40	510	980	1450	1920	2390	3100	4280		
	1550	0.75	1550	2710	X	X	110	580	1050	1520	1990	2460	3165	4345	Green	
		0.875	1550	2906	X	X	X	385	855	1325	1795	2265	2970	4150		
		1.125	1550	3294	X	X	X	X	465	935	1405	1875	2580	3760		
		1.5	1550	3875	X	X	X	X	X	355	825	1295	2000	3180		
1880	2	1550	4650	X	X	X	X	X	X	50	520	1225	2405			
	0.75	1880	3290	X	X	X	X	470	940	1410	1880	2585	3765	Pink & Green		
	0.875	1880	3525	X	X	X	X	235	705	1175	1645	2350	3530			
	1.125	1880	3995	X	X	X	X	X	235	705	1175	1880	3060			
	1.5	1880	4700	X	X	X	X	X	X	X	470	1175	2355			
2	1880	5640	X	X	X	X	X	X	X	X	235	1415				

X—Indicates where the listed supply pressure is not sufficient to overcome the opposing bias spring effect.

Table 5. Fisher 585C Size 25 and 50 Actuator Thrust Capabilities, Metric Units (spring retracts actuator stem)

ACTUATOR SIZE	SPRING RATE, N/mm	ACTUATOR STEM TRAVEL, mm	SPRING THRUST W/ ACTUATOR STEM RETRACTED, N	SPRING THRUST W/ ACTUATOR STEM EXTENDED, N	NET THRUST FOR 585C WITH ACTUATOR STEM FULLY EXTENDED AT FULL TRAVEL										SPRINGS USED, BY COLOR
					Operating Pressure, bar										
					2.8	3.4	4.1	4.8	5.5	6.2	6.9	7.6	8.6	10.3	
					Force, N										
25	0	All	0	0	4626	5783	6939	8096	9252	10,409	11,565	12,722	14,457	17,348	Springs Not Used
	35.0	14.3	890	1393	3247	4404	5560	6717	7829	8985	10,142	11,298	13,033	15,925	Gold
		19.1	890	1558	3069	4226	5382	6539	7695	8852	10,008	11,165	12,900	15,791	
		22.2	890	1669	2936	4092	5249	6405	7562	8718	9875	11,032	12,766	15,658	
		28.6	890	1891	2713	3870	5026	6183	7340	8496	9653	10,809	12,544	15,435	
	70.1	14.3	1780	2781	1824	2980	4137	5293	6450	7606	8763	9919	11,654	14,546	Light Green
19.1		1780	3115	1512	2669	3825	4982	6139	7295	8452	9608	11,343	14,234		
22.2		1780	3338	1290	2447	3603	4760	5916	7073	8229	9386	11,121	14,012		
28.6		1780	3783	845	2002	3158	4315	5471	6628	7784	8941	10,676	13,567		
87.6	14.3	2225	3475	1156	2313	3470	4626	5783	6939	8096	9252	10,943	13,834	White	
	19.1	2225	3894	712	1868	3025	4181	5338	6494	7651	8807	10,542	13,434		
	22.2	2225	4174	445	1601	2758	3914	5071	6227	7384	8541	10,275	13,167		
	28.6	2225	4730	X	1068	2224	3381	4493	5649	6806	7962	9697	12,588		
122.6	14.3	3115	4868	X	890	2046	3203	4359	5516	6672	7829	9564	12,455	Gold & White	
	19.1	3115	5451	X	311	1468	2624	3781	4938	6094	7251	8985	11,877		
	22.2	3115	5843	X	X	1112	2269	3381	4537	5694	6850	8585	11,476		
	28.6	3115	6622	X	X	311	1468	2624	3781	4938	6094	7829	10,720		
157.7	14.3	4005	6257	X	X	667	1824	2980	4137	5293	6450	8185	11,076	Light Green & White	
	19.1	4005	7009	X	X	X	1068	2224	3381	4537	5694	7428	10,320		
	22.2	4005	7512	X	X	X	578	1735	2891	4048	5204	6939	9831		
	28.6	4005	8513	X	X	X	X	712	1868	3025	4181	5916	8807		
50	0	All	0	0	8180	10,200	12,300	14,300	16,400	18,400	20,500	22,500	25,600	30,700	Springs Not Used
	57.8	19.1	1468	2571	5827	7918	10,008	12,099	14,190	16,280	18,416	20,506	23,620	28,869	Pink
		22.2	1468	2753	5649	7740	9831	11,921	14,012	16,102	18,193	20,328	23,442	28,691	
		28.6	1468	3118	5249	7384	9475	11,565	13,656	15,747	17,837	19,928	23,086	28,335	
		38.1	1468	3670	4715	6806	8896	10,987	13,122	15,213	17,303	19,394	22,552	27,801	
	105.1	19.1	2669	4671	3736	5827	7918	10,008	12,099	14,190	16,280	18,371	21,529	26,778	Light Blue
22.2		2669	5004	3381	5471	7562	9653	11,788	13,878	15,969	18,060	21,218	26,467		
28.6		2669	5671	2713	4804	6895	8985	11,121	13,211	15,302	17,392	20,551	25,800		
38.1		2669	6672	1735	3825	5916	8007	10,097	12,188	14,279	16,369	19,528	24,777		
162.9	19.1	4137	7242	1157	3247	5338	7428	9519	11,610	13,745	15,836	18,949	24,198	Pink & Light Blue	
	22.2	4137	7758	623	2713	4804	6939	9030	11,121	13,211	15,302	18,460	23,709		
	28.6	4137	8790	X	1690	3781	5872	7962	10,097	12,188	14,279	17,392	22,641		
	38.1	4137	10,342	X	133	2224	4315	6450	8541	10,631	12,722	15,880	21,129		
271.4	19.1	6894	12054	X	X	489	2580	4670	6761	8852	10942	14078	19,328	Green	
	22.2	6894	12925	X	X	X	1712	3803	5894	7984	10075	13211	18,460		
	28.6	6894	14652	X	X	X	X	2068	4159	6249	8340	11476	16,725		
	38.1	6894	17236	X	X	X	X	X	1579	3670	5760	8896	14,145		
329.2	19.1	8362	14634	X	X	X	X	2091	4181	6272	8362	11498	16,748	Pink & Green	
	22.2	8362	15679	X	X	X	X	1045	3136	5226	7317	10453	15,702		
	28.6	8362	17770	X	X	X	X	X	1045	3136	5226	8362	13,612		
	38.1	8362	20906	X	X	X	X	X	X	X	2091	5226	10,476		
50.8	8362	25087	X	X	X	X	X	X	X	X	1045	6294			

X—Indicates where the listed supply pressure is not sufficient to overcome the opposing bias spring effect.

Table 6. Fisher 585CR Size 25 and 50 Actuator Thrust Capabilities, U.S. Units (spring extends actuator stem)

ACTUATOR SIZE	SPRING RATE, lb/in	SPRING THRUST W/ ACTUATOR STEM EXTENDED, POUNDS	TOTAL THRUST FOR 585CR WITH ACTUATOR STEM FULLY EXTENDED										SPRINGS USED, BY COLOR
			Operating Pressure, psig ⁽¹⁾										
			40	50	60	70	80	90	100	110	125	150	
			Force, Pounds										
25 ⁽²⁾	0	0	1040	1300	1560	1820	2080	2340	2600	2860	3250	3900	Springs Not Used
	200	200	1240	1500	1760	2020	2280	2540	2800	3060	3450	X	Gold
	400	400	1440	1700	1960	2220	2480	2740	3000	3260	3650	X	Light Green
	500	500	1540	1800	2060	2320	2580	2840	3100	3360	3750	X	White
	700	700	1740	2000	2260	2520	2780	3040	3300	3560	X	X	Gold & White
900	900	1940	2200	2460	2720	2980	3240	3500	3760	X	X	Light Green & White	
50 ⁽³⁾	0	0	1840	2300	2760	3220	3680	4140	4600	5060	5750	6900	Springs Not Used
	330	330	2210	2680	3150	3620	4090	4560	5030	5500	6205	X	Pink
	600	600	2480	2950	3420	3890	4360	4830	5300	5770	6475	X	Light Blue
	930	930	2810	3280	3750	4220	4690	5160	5630	6100	6805	X	Pink & Light Blue
	1550	1550	3430	3900	4370	4840	5310	5780	6250	6720	X	X	Green
1880	1880	3760	4230	4700	5170	5640	6110	6580	7050	X	X	Pink & Green	

X—Indicates where the listed supply pressure is not sufficient to overcome the opposing bias spring effect.
 1. The maximum design pressure for size 25 and 50 actuator is 150 psig.
 2. Maximum thrust is 3900 lbs.
 3. Maximum thrust is 6900 lbs.

Table 7. Fisher 585CR Size 25 and 50 Actuator Thrust Capabilities, Metric Units (spring extends actuator stem)

ACTUATOR SIZE	SPRING RATE, N/mm	SPRING THRUST W/ ACTUATOR STEM EXTENDED, N	TOTAL THRUST FOR 585CR WITH ACTUATOR STEM FULLY EXTENDED										SPRINGS USED, BY COLOR
			Operating Pressure, bar ⁽¹⁾										
			2.8	3.4	4.1	4.8	5.5	6.2	6.9	7.6	8.6	10.3	
			Force, N										
25 ⁽²⁾	0	0	4626	5782	6939	8095	9251	10408	11565	12721	14456	17347	Springs Not Used
	35.0	890	5516	6672	7828	8985	10141	11298	12454	13610	15346	X	Gold
	70.0	1780	6405	7562	8718	9874	11031	12188	13344	14500	16235	X	Light Green
	87.6	2225	6850	8006	9163	10319	11476	12632	13789	14945	16680	X	White
	122.6	3115	7740	8896	10052	11209	12365	13655	14678	15835	X	X	Gold & White
157.6	4005	8629	9786	10942	12099	13255	14412	15568	16724	X	X	Light Green & White	
50 ⁽³⁾	0	0	8180	10200	12300	14300	16400	18400	20500	22500	25600	30700	Springs Not Used
	57.8	1468	9830	11921	14011	16102	18192	20282	22373	24464	27600	X	Pink
	105.1	2670	11031	13122	15212	17303	19393	21484	23574	25665	28800	X	Light Blue
	162.8	4135	12499	14589	16680	18770	20861	22952	25042	27133	30269	X	Pink & Light Blue
	271.4	6894	15256	17347	19438	21528	23619	25709	27800	29891	X	X	Green
329.2	8362	16724	18815	20906	22996	25087	27177	29268	31358	X	X	Pink & Green	

X—Indicates where the listed supply pressure is not sufficient to overcome the opposing bias spring effect.
 1. The maximum design pressure for size 25 and 50 actuator is 10.3 bar.
 2. Maximum thrust is 17347 N.
 3. Maximum thrust is 31358 N.

Table 8. Fisher 585C Thrust (springless construction)

ACTUATOR SIZE	PISTON AREA	TOTAL THRUST FOR 585C ⁽¹⁾										MAXIMUM ALLOWABLE THRUST
		Operating Pressure, bar ⁽³⁾										
		2.8	3.4	4.1	4.8	5.5	6.2	6.9	7.6	8.6	10.3	
	cm ²	Force, Newtons ⁽²⁾										Newtons
25	168	4630	5780	6940	8100	9260	10400	11600	12700	14500	17300	17300
50	303	8180	10200	12300	14300	16400	18400	20500	22500	25600	30700	31400
60	358	9880	12300	14800	17300	19800	22200	24700	27200	30900	36900	36900
68	571	15700	19700	23600	27600	31500	35400	39400	43300	49200	55600	55600 ⁽⁴⁾
80	571	15700	19700	23600	27600	31500	35400	39400	43300	49200	58700	58700
100	842	23200	29000	34800	40600	46400	52200	58000	63900	72600	86700	86700
130	1430	39400	49300	59100	69000	78700	88500	98800	108100	X	X	111200
ACTUATOR SIZE	PISTON AREA	Operating Pressure, psig ⁽³⁾										MAXIMUM ALLOWABLE THRUST
		40	50	60	70	80	90	100	110	125	150	
		Force, Pounds ⁽²⁾										
25	26	1040	1300	1560	1820	2080	2340	2600	2860	3250	3900	3900
50	47	1840	2300	2760	3220	3680	4140	4600	5060	5750	6900	7050
60	55.5	2220	2780	3330	3890	4440	5000	5550	6110	6940	8300	8300
68	88.5	3540	4430	5310	6200	7080	7970	8850	9740	11100	12500	12500 ⁽⁴⁾
80	88.5	3540	4430	5310	6200	7080	7970	8850	9740	11100	13200	13200
100	130.5	5220	6530	7830	9140	10440	11700	13100	14400	16300	19500	19500
130	221.5	8860	11100	13300	15500	17700	19900	22200	24300	X	X	25000

X—Indicates where the listed supply pressure will exceed the maximum thrust allowable.
1. The maximum design pressure for size 25 through 100 actuators is 10.3 bar (150 psig). The size 68 and 130 actuators are limited to 9.7 and 7.8 bar (140 and 113 psig) respectively.
2. The size 25 and 50 data is for the construction without a bias spring.
3. Minimum operating pressure for sizes 60-130 actuators is 2.4 bar (35 psig).
4. The size 68 actuator with a handwheel is limited to 40000 Newtons (9000 lb) thrust.

Principle of Operation

The 585C piston actuator (figures 2 and 3) uses a piston that moves inside the actuator cylinder. An O-ring (see figure 3) provides a seal between the piston and the cylinder.

From an equilibrium state, the actuator reacts to a force unbalance that is created by increasing supply pressure on one side of the piston, and decreasing it on the other. This moves the piston up or down, and results in a repositioning of the valve plug.

Actuator with Handwheel (figures 2 and 6)

The handwheel version can be used to open or close the valve manually (either during normal operation or in an emergency), to position the valve at any point in the stroke, or to act as a travel stop.

Size 25 and 50 actuators use an integral top-mounted handwheel. See figure 6.

Size 60 to 130 actuators use a side-mounted handwheel, and come with a spring-loaded ball detent which prevents vibration from changing the handwheel setting. Handwheels for most types are either 203 mm (8 inches) in diameter with beveled gears or 432 mm (17 inches) in diameter with worm gears.

Handwheel Specifications

Table 9. Fisher 585C Handwheel Specifications

ACTUATOR SIZE	HANDWHEEL MOUNTING	HANDWHEEL DIAMETER	TURNS PER mm TRAVEL	MAXIMUM RIM FORCE REQUIRED	HANDWHEEL OUTPUT FORCE	HANDWHEEL WEIGHT
		mm		Newtons	Newtons	kg
25	Top-Mounted	356	0.5	325	12,810	17
50		482	0.5	445	23,790	20
60 ⁽¹⁾	Integral Side-Mounted	203	0.6	276	40000	28
60 ⁽²⁾		356	0.6	160	40000	30
68 ⁽¹⁾		203	0.6	276	40000	30
68 ⁽²⁾		356	0.6	160	40000	33
80		432	0.4	423	50000	35
100		432	0.4	623	75600	94
130		432	0.4	623	75600	123
ACTUATOR SIZE	HANDWHEEL MOUNTING	HANDWHEEL DIAMETER	TURNS PER INCH TRAVEL	MAXIMUM RIM FORCE REQUIRED	HANDWHEEL OUTPUT FORCE	HANDWHEEL WEIGHT
		Inches		Pounds	Pounds	Pounds
25	Top-Mounted	14	12	73	2880	37
50		19	12	100	5350	45
60 ⁽¹⁾	Integral Side-Mounted	8	16	62	9000	61
60 ⁽²⁾		14	16	36	9000	66
68 ⁽¹⁾		8	16	62	9000	66
68 ⁽²⁾		14	16	36	9000	71
80		17	10	95	11250	77
100		17	10	140	17000	208
130		17	10	140	17000	272

1. 2 and 4 inch maximum travel constructions.
2. 8 inch maximum travel construction.

Figure 2. Fisher 585C Piston Actuator with Handwheel

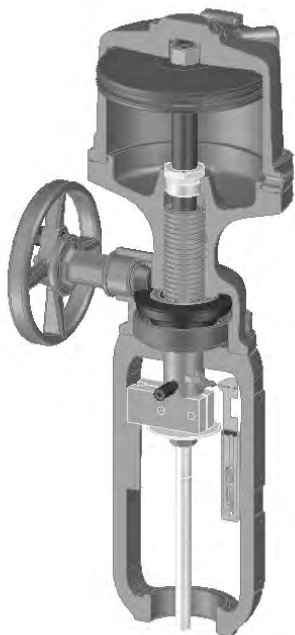

E0410

Figure 3. Fisher 585C Piston Actuator with Spring Return

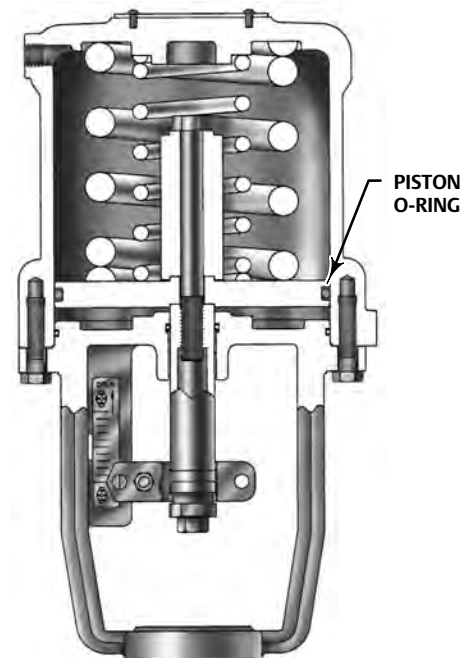

W7447-1

Actuator with Spring Return (figure 3)

585C size 25 and 50 actuators are available with bias springs in two configurations. The 585C actuator, with the bias spring under the piston, fully retracts the actuator stem upon loss of cylinder pressure. The 585C actuator, with the bias spring on top of the piston, fully extends the actuator stem upon loss of cylinder pressure. No additional parts are required to convert from one actuator type to the other.

For more detailed information on the 3610 positioner and DVC6200 digital valve controllers, refer to the Principle of Operation section in the 3610J Instruction Manual ([D200149X012](#)) and [DVC6200](#) instruction manuals.

Installation

▲ WARNING

To avoid personal injury or property damage caused by cylinder fracture as a result of piston impact, install the stem connector securely before supplying pressure to the positioner. Use only a regulator-controlled air supply to move the actuator piston so that you can install the stem connector. Do not use the positioner to move the actuator piston before installing the stem connector.

Always wear protective gloves, clothing, and eyewear when performing any installation operations to avoid personal injury.

To avoid personal injury or property damage caused by bursting of pressure-retaining parts, be certain the cylinder pressure or other pressure ratings do not exceed the limits listed in table 1. Use pressure-limiting or pressure-relieving devices to prevent cylinder pressure or other pressure ratings from exceeding these limits.

Check with your process or safety engineer for any additional measures that must be taken to protect against process media.

If installing into an existing application, also refer to the WARNING at the beginning of the Maintenance sections in this instruction manual.

When an actuator and valve are shipped together as a control valve assembly, the actuator is normally mounted on the valve. Follow the valve instructions when installing the control valve in the pipeline. If the actuator is shipped separately or if it is necessary to mount the actuator on the valve, perform the Actuator Mounting procedures in this instruction manual corresponding to your actuator size. For information on mounting valve positioners, refer to the 3610J Instruction Manual (D200149X012) or DVC6200 instruction manuals for details.

If a 585C actuator is being installed without a positioner, the cylinder loading pressures should be supplied through a 4-way solenoid valve or a switching valve. The bottom side of the piston is pressured through the bottom side of the mounting flange on the actuator yoke (key 6, figures 5 and 7) for sizes 25 and 50 or the connection at the lower side of the cylinder (key 1, figure 10 to 15) for sizes 60 to 130. The top side of the piston is pressured through the connection in the cylinder cover (key 1 for figures 5, 7; and 10 to 15).

The supply pressure medium should be clean, dry filtered air. If the supply source is capable of exceeding the maximum actuator operating pressure or positioner supply pressure, appropriate steps must be taken during installation to protect the positioner and all connected equipment against overpressure.

▲ WARNING

Dropping the actuator and any attached accessories and/or valve may cause personal injury and/or equipment damage. For all mounting procedures use an adequately sized chain, sling, hoist, or crane to handle the actuator and any attached accessories and/or valve. Use caution during lifting and handling to prevent slippage, swinging, faulty equipment connections, or sudden shock loads.

NOTICE

To avoid damage to actuator parts and difficult operation of actuator handwheels, open the bypass valve before using a handwheel.

If manual operation is required, the actuator should be equipped with a manual handwheel. To manually move the piston rod with the handwheel, first open the bypass needle valve (key 66 for sizes 25 and 50, figure 9; key 92 for sizes 60 to 130, figure 16), place the handwheel pointer in the neutral position, and insert the locking pin in the sleeve assembly (for size 60-130). Then turn the handwheel in the selected direction as indicated on the wheel.

The control valve should be located where it will be accessible for servicing. Room should be left above and below the control valve to permit removal of the actuator and valve plug.

Bypass Assembly

The bypass is furnished as shown in figures 6, 8, 9, and 16 only when a handwheel actuator is specified. The bypass allows the pressure to equalize on either side of the piston, so that the manual actuator can be used to position the valve.

Flow through the bypass tubing is controlled by an angle needle valve (key 66 for figures 6, 8, and 9; and key 92 for figure 16), which is operated manually. This valve should be closed when air pressure is being used to operate the valve.

Three-Way Valve Applications Note

⚠ WARNING

To avoid loss of control of process fluid and subsequent personal injury or property damage caused by bursting of pressure-retaining parts, be sure the cylinder pressure does not exceed 80 psig in high cycle-rate, fast stroking speed, three-way valve applications.

In three-way valve applications where the actuator fully strokes at a frequency of once per minute or faster, and the stroking speed is rapid (less than 0.5 seconds per stroke), there is a possibility that the stem can fracture at the plug if the actuator cylinder pressure is greater than 80 psig. This can cause loss of control of process fluid and further damage to the actuator. Consideration should be given to the use of high-strength, fatigue-resistant stem materials in these applications.

Actuator Mounting

Size 25 and 50 Actuator Mounting

The following procedure describes how to mount a 585C actuator size 25 and 50 on a push-down-to-close valve so that the piston stem to valve plug stem connection allows full travel and proper shutoff. Key numbers referenced in the following steps are shown in figures 5 through 9.

1. If not already removed, remove the stem connector (key 12) by loosening the cap screws (key 14).
2. Thread the stem connector nuts (keys 13 and 15) onto the valve stem, and run the nuts to the bottom of the valve stem threads.
3. Push the valve plug stem until the valve plug is closed for push-down-to-close valve plug action.
4. Place the actuator on the bonnet of the valve and secure the actuator tightly to the bonnet with the yoke locknut.

NOTICE

In the following procedure, do not rotate the valve plug while it is seated since this may cause damage to the seating surface and thereby allow excessive leakage. Also, during adjustment, use tools carefully to avoid damaging the valve plug stem. A damaged valve plug stem could cut the packing and allow leakage.

Note

When using an actuator with handwheel in the following step to stroke the valve plug, be sure the bypass valve (key 66, figure 6, 8, or 9) is open. Rotating the handwheel (key 47, figure 6, 8, or 9) clockwise extends the actuator stem (key 10); rotating the handwheel counterclockwise retracts the actuator stem.

5. Perform one of the following procedures (a or b as appropriate):
 - a. For a 585C actuator with spring retraction upon loss of cylinder pressure (figures 5 and 6) on a push-down-to-close valve, manually move the valve plug to the seated position. Rotate the handwheel or apply pressure to the pressure connection in the cylinder (key 1) until the piston (key 3) and actuator stem (key 10) move down the specified travel. Run the stem connector nut (key 13) up on the valve stem until it contacts the actuator stem. Be sure the flats on the actuator stem are perpendicular to the scale indicator web on the yoke (key 6). Adjust the stem connector nut as necessary, so that the flats on the nut and the actuator stem are parallel. Clamp the actuator stem and stem connector nut together with the stem connector (key 12) and the two cap screws and hex nuts (keys 14 and 23). Run the hex nut (key 15) up the valve stem and tighten against the stem connector nut (key 13).
 - b. For a 585C actuator with spring extension upon loss of cylinder pressure (figures 7 and 8) with push-down-to-close valve, manually move the valve plug to the seated position. Run the stem connector nut (key 13) up the valve stem until it contacts the actuator stem (key 10). Rotate the handwheel or apply pressure to the pressure connection in the yoke (key 6) to move the actuator stem (key 10) approximately 1/4 inch away from the stem connector nut. Rotate the stem connector nut so that it moves up the valve stem two full turns. Manually move the valve plug so that the stem connector nut again contacts the actuator stem. Be sure the flats on the actuator stem are perpendicular to the scale indicator web on the yoke (key 6). Adjust the stem connector nut, as necessary, so that the flats on the nut and the actuator stem are parallel. Clamp the actuator stem and stem connector nut together with the stem connector (key 12) and the two cap screws and hex nuts (keys 14 and 23). Run the hex nut (key 15) up the valve stem and tighten it against the stem connector nut (key 13).
6. Cycle the actuator several times to check for proper operation.

Note

In the following step, make sure the correct travel indicator scale (key 19) is used per the Parts List for the desired travel.

7. If necessary, remove the travel indicator scale screws (key 18) and reposition the travel indicator scale (key 19) so that the scale arrow points in the same direction as the valve plug moves when opening. Close the valve. Adjust the scale up or down so that the stem connector (key 12) indicator lines up with the closed mark on the scale. Secure the scale with the scale screws.

Size 60-130 Actuator Mounting

The following procedure describes how to mount a 585C size 60 to 130 actuator on a push-down-to-close valve so that the piston stem to valve plug stem connection allows full travel and proper shutoff. Key numbers referenced in the following steps are shown in figures 10 through 15.

If an actuator is purchased separately for field installation on a control valve, mount it on the valve and secure it in place with the yoke locknut for size 60 and 68 or with eight bolts on actuator sizes 80, 100, and 130 which use a 127 mm (5-inch) yoke boss.

The stem connector should then be set up to clamp the actuator stem and valve plug stem together to provide the proper valve travel. This procedure is outlined in the Stem Connector Assembly procedures of this instruction manual.

Stem Connector Assembly (Size 60-130)

NOTICE

To avoid damaging the seating surfaces, do not rotate the valve plug while it is seated. Also avoid damage to the valve plug stem by careful use of tools during travel adjustment.

⚠ WARNING

- To avoid personal injury or property damage caused by cylinder fracture as a result of piston impact, install the stem connector securely before supplying pressure to the positioner. Incomplete engagement of valve stem and/or actuator stem in the stem connector can result in stripped threads or improper operation. Be sure that the length of each stem clamped in the stem connector is equal to or greater than the diameter of that stem. Do not loosen the cap screws when the stem connector has spring or loading pressure force applied to it.
- Install the stem connector securely before a positioner is mounted to the actuator and pressurized, using only a regulator- controlled air supply, *not the positioner*, to move the actuator piston to position the actuator stem.
- To avoid personal injury or property damage, keep hands and tools out of the actuator stem travel path while pressuring the actuator to move the actuator stem in the following steps.

585C Size 60-130 Direct-Acting (Push-Down-to-Close) Valves

1. With the valve assembled and the actuator mounted, make sure the valve plug is in the closed position, and the actuator is at the top of its stroke. Then screw the two stem locknuts (key 15) all the way onto the stem thread and place the travel indicator disk (key 32) (if any) on the stem locknuts.
2. Keeping your hands away from any moving parts, use a regulator-controlled air supply to move the actuator stem (key 10) down from the top of its stroke to the specified valve travel.
3. Using one half of the stem connector (key 12), align the actuator stem and the valve stem with threads from *both* stems mated root-to-crest with the stem connector. Install the other half of the stem connector and tighten the cap screws. With the stem locknuts (key 15), raise the travel indicator disk (key 32) to the stem connector (key 12).
4. Cycle the actuator to check availability of desired total travel and that the valve plug seats before the actuator contacts the lower travel stop. Minor travel adjustments can be made by loosening the stem connector (key 12) slightly, tightening the locknuts (key 15) together, and screwing the valve stem either into or out of the stem connector (key 12) with a wrench on the locknuts (key 15). If the valve stem cannot be turned, as with a bellows seal bonnet, remake the stem connection to achieve the desired travel.
5. Once the total travel is adequate, tighten the stem connector (key 12) securely, lock the stem locknuts (key 15) against the connector, and adjust the indicator scale (key 19) on the yoke to show correct valve plug position.

6. Provide a gauge to measure the pressure to the actuator. Make a final adjustment of the actuator or its positioner to set the starting point of valve travel and to obtain full travel for the given instrument range.

585C Size 60-130 Reverse-Acting (Push-Down-to-Open) Valves

1. Keeping your hands away from moving parts, pressure the actuator, using a regulator-controlled air supply, to move the actuator stem (key 10) to the extreme upward position then reverse loading pressure to lower the actuator stem (key 10) approximately 3 mm (1/8 inch).
2. Pull the valve stem up to seat the valve plug.
3. Using one half of the stem connector (key 12), align the actuator stem and the valve stem with threads from *both* stems mated root-to-crest with the stem connector. Install the other half of the stem connector and tighten the cap screws.
4. If there is a travel indicator disk (key 32), raise it to the stem connector (key 12) and tighten in position with the stem locknuts (key 15). The indicator disk (key 32) should show the valve to be open with the piston (key 3) at the bottom of its stroke. If it does not, loosen two screws (key 18) and shift the travel indicator scale (key 19) to indicate OPEN.
5. Cycle the actuator to check availability of desired total travel and that the valve plug seats before the actuator contacts the upper travel stop. Minor travel adjustments can be made by loosening the stem connector (key 12) slightly, tightening the locknuts (key 15) together, and screwing the valve stem either into or out of the stem connector (key 12) with a wrench on the locknuts. If the valve stem cannot be turned, as with a bellows seal bonnet, remake the stem connection to achieve the desired travel.
6. Once the total travel is adequate, tighten the stem connector (key 12) securely, lock the stem locknuts (key 15) against the connector, and adjust the indicator scale (key 19) on the yoke to show correct valve plug position.
7. Provide a gauge to measure the pressure to the actuator. Make a final adjustment of the actuator or its positioner to set the starting point of valve travel and to obtain full travel for the given instrument range.

585C Handwheels

Handwheel Operation (Sizes 25 and 50)

Key numbers referenced in the following steps are shown in figures 6, 8, and 9 for the 585C actuator.

The handwheel assembly on a 585C actuator may be used as an adjustable travel stop to limit full upward or downward travel of the actuator stem (key 10), or as a manual actuator to fully stroke the valve. When the neutral indicator (key 42) is in the neutral position, travel is not restricted. With clockwise handwheel (key 47) rotation, the operating nut (key 46) is screwed downward, forcing the actuator stem (key 10) down. With counterclockwise rotation, the operating nut is screwed upward against the handwheel stem washer (key 45), pulling the actuator stem up.

Note

When using an actuator with handwheel to stroke the valve plug or position the travel stop, be sure the bypass valve (key 66) is open.

Handwheel Operation (Sizes 60-130)

The 585C handwheel assembly for sizes 60 through 130 actuators (figures 10 and 12) has three main functions:

- a. To open or close the valve manually or to position the valve at any point in the stroke, regardless of the cylinder pressure. The tapered pin is inserted during manual throttling operation.
- b. To act as a travel stop to limit full opening or closing of the valve but not both at the same time. As shown in table 11, the tapered pin is left out when the assembly is used as a travel stop.
- c. To open or close the valve manually in an emergency without the necessity of inserting the tapered pin, as shown in table 11.

Bevel gears are used in sizes 60 and 68 and worm gears in sizes 80 through 130. A spring-loaded ball detent is provided in the handwheel to prevent a change in setting due to vibration. The following table 10 lists pertinent information on these handwheel units.

Table 10. Fisher 585C Size 60 to 130 Handwheel Information

Actuator Size	60-68	80-130
Handwheel Diameter, Inches	8	17
Turns Required for One Inch of Travel	16	10

Table 11. Fisher 585C Size 60 to 130 Handwheel Information with Travel Stop Function and Emergency Operation without Tapered Pin Engaged

Actuator Size	Maximum Travel, Inch	Used as Upper Travel Stop	To Close the Valve without Tapered Pin Engaged	Used as Lower Travel Stop	To Open the Valve without Tapered Pin Engaged
60 and 68	2	Yes			Yes
	4 and 8				No
80, 100, and 130	4	Yes			Yes
	8				Yes but with travel restriction

Maintenance (Sizes 25 and 50)

Actuator parts are subject to normal wear and must be inspected and replaced as necessary. The frequency of inspection and replacement depends on the severity of service conditions. This section provides two separate procedures, one on Replacing Handwheel Housing O-Ring or Thrust Bearings, and the other on Replacing Seals, Changing Action, or Changing Bias Spring(s).

Refer to figures 6 and 8.

For an actuator with handwheel, a grease fitting (key 50) is provided on the bearing cover (key 38) for periodic bearing lubrication with lithium grease (key 24).

⚠ WARNING

Avoid personal injury from sudden release of process pressure. Before performing any maintenance operations:

- Do not remove the actuator from the valve while the valve is still pressurized.
- Always wear protective gloves, clothing, and eyewear when performing any maintenance operations to avoid personal injury.
- Disconnect any operating lines providing air pressure, electric power, or a control signal to the actuator. Be sure the actuator cannot suddenly open or close the valve.
- Use bypass valves or completely shut off the process to isolate the valve from process pressure. Relieve process pressure on both sides of the valve. Drain the process media from both sides of the valve.

- Vent the power actuator loading pressure and release all bias spring compression force by slowly unscrewing the cylinder cover bolting in a crisscross pattern.
- Use lock-out procedures to be sure that the above measures stay in effect while you work on the equipment.
- The valve packing box may contain process fluids that are pressurized, *even when the valve has been removed from the pipeline*. Process fluids may spray out under pressure when removing the packing hardware or packing rings, or when loosening the packing box pipe plug.
- Check with your process or safety engineer for any additional measures that must be taken to protect against process media.

Replacing Handwheel Housing O-Ring or Thrust Bearings (Sizes 25 and 50)

Perform this procedure if inspecting or replacing the handwheel housing O-ring, handwheel thrust bearings, or any other handwheel parts located above the cylinder (key 1). Inspection or replacement of the cylinder O-ring, handwheel stem, or handwheel stem jam nut (key 57, 56, or 52) are covered in the Replacing Seals, Changing Action, or Changing Bias Spring(s) procedure. Key numbers are referenced in figure 6 for a 585C actuator (spring retracts actuator rod) and in figure 8 for a 585C actuator (spring extends actuator rod).

Note

This procedure may be performed without removing the cylinder, or yoke (key 1 or 6) from the bonnet of the valve.

Disassembly

Isolate the control valve from the line pressure, release pressure from both sides of the valve body, and drain the process media from both sides of the valve. Shut-off all pressure lines and power to the actuator, and release all pressure from the actuator. Use lock-out procedures to be sure that the above measures stay in effect while you work on the equipment.

WARNING

Refer to the **WARNING** at the beginning of the Maintenance section in this instruction manual.

1. Shut off the bypass valve (key 66). Remove the cylinder pressure piping and bypass tubing from the bypass tees (key 68) on the cylinder (key 1).
2. Turn the handwheel (key 47) in the appropriate direction so the neutral indicator (key 42) is behind the NEUTRAL position of the neutral indicator plate (key 37).
3. Unscrew and remove the neutral indicator cover (key 35).
4. Remove the handwheel retaining ring, handwheel, and locking key (keys 48, 47, and 65).
5. Loosen the bearing cover set screws (key 51), and unscrew and carefully remove the bearing cover (key 38).
6. Remove the handwheel housing O-ring (key 58) and the top set of thrust bearings (key 39).
7. Since both the handwheel housing (key 36) and the operating nut (key 46) have left-hand threads, unscrew the handwheel housing by turning it clockwise off the operating nut. Carefully remove the detent ball and detent spring (keys 64 and 63), and remove the bottom set of thrust bearings (key 39).

8. Unscrew the handwheel stem cap screw (key 60) while using a 7/8 inch wrench to hold the handwheel stem (key 56). Remove the handwheel stem washer (key 45), and the operating nut (key 46) with attached neutral indicator (key 42).
9. Unscrew the neutral indicator (key 42) counterclockwise if necessary to separate it from the operating nut (key 46).

Reassembly

1. If the neutral indicator (key 42) was removed, coat its threads with thread locking adhesive (medium strength) (key 70) and screw it into the operating nut (key 46). Position the 90-degree elbow of the neutral indicator so that it will not interfere with the neutral indicator cover (key 35) when assembled.
2. If necessary, replace the anti-rotation key (key 40), by pushing the key outward from the cylinder (key 1) then install the replacement key (key 40) into the anti-rotation hole of the cylinder.
3. Lubricate the inside surface of the operating nut (key 46) with lithium grease (key 24). Install the operating nut with the attached neutral indicator, and the handwheel stem washer (key 45), onto the handwheel stem (key 56) and secure with the handwheel stem cap screw (key 60). Tighten the cap screw to 169 N•m (125 lbf•ft).
4. Place the bottom set of thrust bearings (key 39) on top of the cylinder (key 1). Insert the detent spring and ball (keys 63 and 64) into the cylinder.
5. Install the handwheel housing O-ring (key 58) on the handwheel housing (key 36). Since both the handwheel housing and the operating nut (key 46) have left-hand threads, thread the handwheel housing onto the operating nut by turning it counterclockwise over the operating nut until the handwheel housing is snug against the bottom set of thrust bearings (key 39).
6. Install the top set of thrust bearings (key 39) over the handwheel housing (key 36).
7. Carefully slide the bearing cover (key 38) over the handwheel housing (key 36) and thread the bearing cover hand tight onto the cylinder (key 1). Secure by tightening the set screws (key 51) to 18 N•m (13 lbf•ft).
8. Install the locking key, handwheel, and handwheel retaining ring (keys 65, 47, and 48).
9. Screw the neutral indicator cover (key 35) hand tight only onto the handwheel housing (key 36).
10. Install the bypass tubing with attached bypass valve (key 66) into the bypass tees (key 68) in the cylinder (key 1).

Replacing Seals, Changing Action, or Changing Bias Spring(s) (Sizes 25 and 50)

Key numbers are referenced in figures 5 and 6 for a 585C actuator (spring retracts actuator rod) and in figures 7 and 8 for a 585C actuator (spring extends actuator rod).

Disassembly

Isolate the control valve from the line pressure, release pressure from both sides of the valve body, and drain the process media from both sides of the valve. Shut-off all pressure lines and power to the actuator, release all pressure from the actuator, and release all bias spring compression force by slowly unscrewing the cylinder cover bolting in a crisscross pattern. Use lock-out procedures to be sure that the above measures stay in effect while you work on the equipment.

▲ WARNING

Refer to the WARNING at the beginning of the Maintenance section in this instruction manual.

For 585C actuators with push-only handwheel, figure 9, be sure the handjack stem is backed out of the cylinder as far as it will go to relieve any extra spring compression.

1. Remove the cylinder pressure piping. With a handwheel construction, perform steps 1. through 2. of the Replacing Handwheel Housing O-Ring or Thrust Bearings procedure.

Note

In the following step, loosen each cylinder-to-yoke cap screw a slight amount in turn in a crisscross pattern to keep the cylinder square with the yoke while relieving spring precompression.

2. While carefully allowing bias spring precompression to be slowly released, remove the cylinder-to-yoke cap screws and cylinder cover (keys 2 and 1).

NOTICE

When performing the following step, set the cylinder on a protective surface to prevent damage to the cylinder surfaces.

3. Remove the cylinder (key 1). Set the cylinder on a protective surface to prevent damage to the cylinder surfaces. With a handwheel construction, inspect the cylinder O-ring (key 57) and replace it if necessary, applying lithium grease (key 24) to the replacement O-ring.
4. Inspect the piston O-ring (key 8) and replace, if necessary. If the only further maintenance to be performed is replacement of the piston O-ring, skip to step 3 of this procedure.

Note

585C actuators may be used with or without the bias springs. In the following procedures, references are made to the bias springs. If the bias springs are not used, disregard references to them when performing the maintenance procedures.

5. Perform one of the following disassembly procedures (a, b, c, d, or e, as appropriate):
 - a. For 585C actuators without handwheel (*If the bias spring is present, it extends the piston rod.*) (figure 7), remove the piston cap screw (key 4), piston (key 3), bias spring(s) (key 16 and/or key 17), and travel stop spacer (key 5).
 - b. For 585C actuators with handwheel (*If the bias spring is present, it extends the piston rod.*) (figure 8), remove the handwheel stem (key 56) with attached piston stud (key 69), piston (key 3), bias spring(s) (key 16 and/or key 17), and travel stop spacer (key 5).
 - c. For 585C actuators without handwheel (*If the bias spring is present, it retracts the piston rod.*) (figure 5), remove the bias spring(s) (key 16 and/or key 17), piston cap screw (key 4), travel stop spacer (key 5) and piston (key 3).
 - d. For 585C actuators with handwheel (*If the bias spring is present, it retracts the piston rod.*) (figure 6), remove the bias spring(s) (key 16 and/or key 17), the handwheel stem (key 56) with attached piston stud (key 69), travel stop spacer (key 5), and piston (key 3).
 - e. For 585C actuators with push-only handwheel (figure 9), remove the cotter pin and slotted nut (keys 73 and 72) and lift off the handwheel. Remove the jam nut (key 52). Remove the cap screws (key 60) and lift off the handwheel housing (key 36). Back the handwheel stem (key 56) out of the housing. Inspect the O-rings (keys 57 and 58). Replace these parts as necessary.
6. If inspection or replacement of the actuator stem O-ring or bearing (key 9 or 11) is necessary, perform steps 1. through 7. Otherwise, skip to step 2, being sure to comply with the note preceding step 2.

7. Loosen the two cap screws in the stem connector (key 14) and remove it. If the actuator is mounted on a valve, separate the actuator stem (key 10) from the valve plug stem. Remove the actuator from the valve.
8. To inspect the actuator stem bearing (key 11), actuator stem O-ring (key 9), or backup ring (key 25, size 50 only) remove the actuator stem (key 10) from the yoke (key 6). Replace these parts if necessary. Apply lithium grease (key 24) to the replacement O-ring or bearing and install it into the yoke.

Assembly

1. Install the actuator stem through the yoke.

Note

Make certain the travel indicator scale (key 19) correctly matches the travel per the Parts List.

2. To achieve the desired construction (either a direct-acting or a reverse-acting 585C actuator), perform one of the following assembly procedures (a, b, or c, as appropriate):
 - a. For 585C actuators (bias spring retracts the piston rod) (figures 5 and 6), center the inner bias spring, if used, (key 17 per table 6 or 7) around the center boss in the yoke (key 6). If used per table 6 or 7, center the outer bias spring (key 16) around the inner bias spring. The outer bias spring should be within the outer boss in the yoke. Put the travel stop spacer and the piston (keys 5 and 3) on the actuator stem. Apply lithium grease (key 24) to the threads of the piston cap screw or piston stud (key 4 or 69). Insert the piston cap screw, or stud plus attached handwheel stem (key 56), through both the piston and travel stop spacer and into the actuator stem. Use a wrench on the flats of the actuator stem to prevent it from turning. Tighten the piston cap screw, or stud plus attached handwheel stem, to 102 N•m (75 lbf•ft) for size 25 actuators or 136 N•m (100 lbf•ft) for size 50 actuators.
 - b. For 585C actuators with push-only handwheel (figure 9), lubricate the O-rings and handjack stem threads with lithium grease. Install the O-ring (key 57) and handjack stem (key 56), turning the screw into the housing as far as possible. Place the O-ring (key 58) over the housing and insert into the cylinder (key 1). Replace the cap screws (key 60) and tighten to 41 N•m (30 lbf•ft) on size 25 actuators or 81 N•m (60 lbf•ft) on size 50 actuators. Replace the jam nut (key 52), handwheel (key 47), and slotted nut and cotter pin (keys 72 and 73).
 - c. For 585C actuators (bias spring extends the piston rod) (figures 7 and 8), put the piston (key 3) on the actuator stem and the travel stop spacer (key 5) on the piston. Apply lithium grease (key 24) to the threads of the piston cap screw or piston stud (key 4 or 69). Insert the piston cap screw, or stud plus attached handwheel stem (key 56), through both the travel stop spacer and piston and into the actuator stem. Use a wrench on the flats of the actuator stem to prevent it from turning. Tighten the piston cap screw, or stud plus attached handwheel stem, to 102 N•m (75 lbf•ft) for size 25 actuators or 136 N•m (100 lbf•ft) for size 50 actuators. Center the inner bias spring, if used, (key 17 per table 4 or 5) around the travel stop spacer. If used per table 4 or 5, center the outer bias spring (key 16) around the inner bias spring. The outer bias spring should be within the outer boss on the piston.
3. Install the piston O-ring (key 8) if it was removed from the piston, and the yoke O-ring (key 7, figure 5 or 7) if it was removed from the yoke (key 6). Apply lithium grease (key 24) to the wall of the cylinder (key 1) and carefully slide the cylinder over the piston O-ring. Be sure the cylinder pressure connection is aligned with the yoke pressure connection. Square the cylinder in place over the yoke O-ring.
4. Line up the cylinder holes with the yoke holes making sure for a handwheel construction that the anti-rotation groove in the handwheel stem (key 56) is aligned with the hole in the cylinder for the anti-rotation key (key 40).

Note

When placing the cylinder on the yoke and tightening the cylinder-to-yoke bolts, be sure to keep the cylinder square and aligned with the top of the yoke.

5. Lubricate the cylinder-to-yoke bolts (key 2) with lithium grease (key 24). In a criss cross pattern, alternately tighten each cylinder-to-yoke bolt a slight amount so that the cylinder stays square with the yoke. When all cylinder surfaces are in contact with the yoke, tighten each cylinder-to-yoke bolt to 70 N•m (55 lbf•ft) for a size 25 or 95 N•m (70 lbf•ft) for a size 50.
6. With a handwheel construction, perform steps 2 through 10 of the Replacing Handwheel Housing O-ring or Thrust Bearings procedure.
7. If the actuator will be mounted on a valve, perform the appropriate actuator mounting procedure. Otherwise, place the stem connector nut (key 13), stem connector (key 12), two cap screws (key 14), two hex nuts (key 23) and hex nut (key 15) in a parts bag and attach the bag to the actuator yoke.

Maintenance (Sizes 60-130)

⚠ WARNING

To avoid personal injury or property damage caused by cylinder fracture as a result of piston impact, install the stem connector securely before supplying pressure to the positioner. Use only a regulator-controlled air supply to move the actuator piston so that you can install the stem connector. Do not use the positioner to move the actuator piston before installing the stem connector.

⚠ WARNING

Avoid personal injury from sudden release of process pressure or uncontrolled process fluid. Before starting disassembly:

- Do not remove the actuator from the valve while the valve is still pressurized.
- Always wear protective gloves, clothing, and eyewear when performing any maintenance operations to avoid personal injury.
- Disconnect any operating lines providing air pressure to the actuator. Be sure the actuator cannot suddenly open or close the valve.
- Use bypass valves or completely shut off the process to isolate the valve from process pressure. Relieve process pressure on both sides of the valve. Drain the process media from both sides of the valve.
- Vent the power actuator loading pressure.
- Use lock-out procedures to be sure that the above measures stay in effect while you work on the equipment.
- The valve packing box may contain process fluids that are pressurized, *even when the valve has been removed from the pipeline*. Process fluids may spray out under pressure when removing the packing hardware or packing rings, or when loosening the packing box pipe plug.
- Check with your process or safety engineer for any additional measures that must be taken to protect against process media.

Key numbers indicated refer to figures 10 through 15.

Isolate the control valve from the line pressure, release pressure from both sides of the valve body, and drain the process media from both sides of the valve. Shut-off all pressure lines and power to the actuator, and release all pressure from the actuator. Use lock-out procedures to be sure that the above measures stay in effect while you work on the equipment.

1. If positioner is not used, go to step 5. If positioner is used, shut off all pressure lines to the positioner then remove all tubing lines (cylinder, instrument and supply) from the positioner.

NOTICE

Do not use wrenches or other tools directly on the valve stem. Damage to the stem surface could result in subsequent damage to the valve packing.

2. Remove the stem connector (key 12) and the piston rod boot (key 29) used to protect the lower end of the actuator stem.
3. Remove the socket head cap screws that hold the cylinder (key 1) to the yoke (key 6).

NOTICE

Exercise care in the following step to prevent damage to the cylinder wall during removal of the cylinder from the yoke.

4. Insert a screwdriver in the two slots on the lower edge of the cylinder casting and pry the cylinder loose from the yoke. Remove the cylinder, being careful not to mar the cylinder wall.
5. The piston (key 3) and actuator stem (key 10) will come out with the cylinder. The piston can then be removed by forcing it out the open end of the cylinder.
6. Unscrew the seal bushing (key 110 or 26), in the upper end of the yoke (key 6).
7. With the unit disassembled, inspect all parts for excessive wear. Replace all worn O-rings. Lubricate with lithium grease for standard service and Krytox[®] GPL 202 for low ambient temperature service (key 24) as indicated on the assembly drawings. Apply sealant (key 70) as indicated on the assembly drawings.
8. When reassembling the actuator after the piston nut (key 4) has been removed from the actuator stem (key 10), clean the threads of the piston nut thoroughly and apply thread sealant to the threads. Tighten the piston nut securely to a torque of 237 N•m (175 lbf•ft) for size 60 actuators, 1290 N•m (950 lbf•ft) for size 68, 80, and 100 actuators, or 2070 N•m (1530 lbf•ft) for size 130 actuators.

Side-Mounted Handwheel Maintenance (Sizes 60-130)

Refer to figure 10, 11, and 12.

1. The handwheel parts should be fully lubricated periodically per figure 10, 11, 12, and 13. Lack of lubrication might cause handwheel to malfunction or reduction of output thrust. A grease fitting (key 140) is provided on sizes 80, 100, and 130. On sizes 60 and 68, remove the handwheel (key 118) and the bevel pinion (key 116) and pack the gear case with lithium grease. Loosen the set screw (key 139) before attempting to remove the pinion and extension.
2. If it is necessary to change the valve plug action from push-down-to-close to push-down-to-open or vice versa, change the handwheel arrangement so that the arrow indicates the correct rotation required to open the valve.
 - a. For sizes 60 and 68, remove the handwheel, invert and replace it. On sizes 60 and 68 (figure 10), remove and replace the spring-loaded ball assembly (key 123) in the opposite side.
 - b. For sizes 80-100, remove the handwheel assembly and install in the opposite end of the gear case by unscrewing the back and front worm retainers (keys 135 and 136, not shown) and turn the handwheel to disengage the bevel pinion (key 116).

Disassembly of Handwheel Constructions (Sizes 60 and 68)

⚠ WARNING

Refer to the WARNING at the beginning of the Maintenance section (Sizes 60-130) in this instruction manual.

To disassemble 585C piston actuators sizes 60 and 68 (with handwheel) for maintenance, perform the following procedures (figure 10 and 12):

1. Be sure that all pressure is out of the cylinder and valve body.
2. Remove all tubing lines to the positioner.
3. Remove the cap screws (key 2) on the underside of either the cylinder flange (key 100) for size 60 or the adapter flange (key 76) for size 68. Remove the cylinder (key 1).
4. Remove the piston nut (key 4), then use a mallet to tap the piston (key 3) off the piston connector (key 107).
5. Remove the handwheel extension (key 117) by loosening the set screw (key 139) and unscrewing the extension. Loosen the hex nut (key 119) and the lockwasher (key 120) to remove the handwheel unit (key 118, 121, 122, and 123) from the bevel pinion (key 116). Slide the bevel pinion (key 116) out of the handwheel extension (key 117) and slide the bushing (key 124) out of the bevel pinion (key 116). Inspect the bushing (key 124) and the bevel pinion (key 116) for wearing or damage, and replace with new parts as needed. The bushing (key 124) is a directional design and its insider radius should be installed to the bevel pinion (key 116) gear side mating with the bevel pinion shoulder radius as shown in figure 4.

Figure 4. Fisher 585C Size 60 and 68 Handwheel Directional Bushing Design and Installation

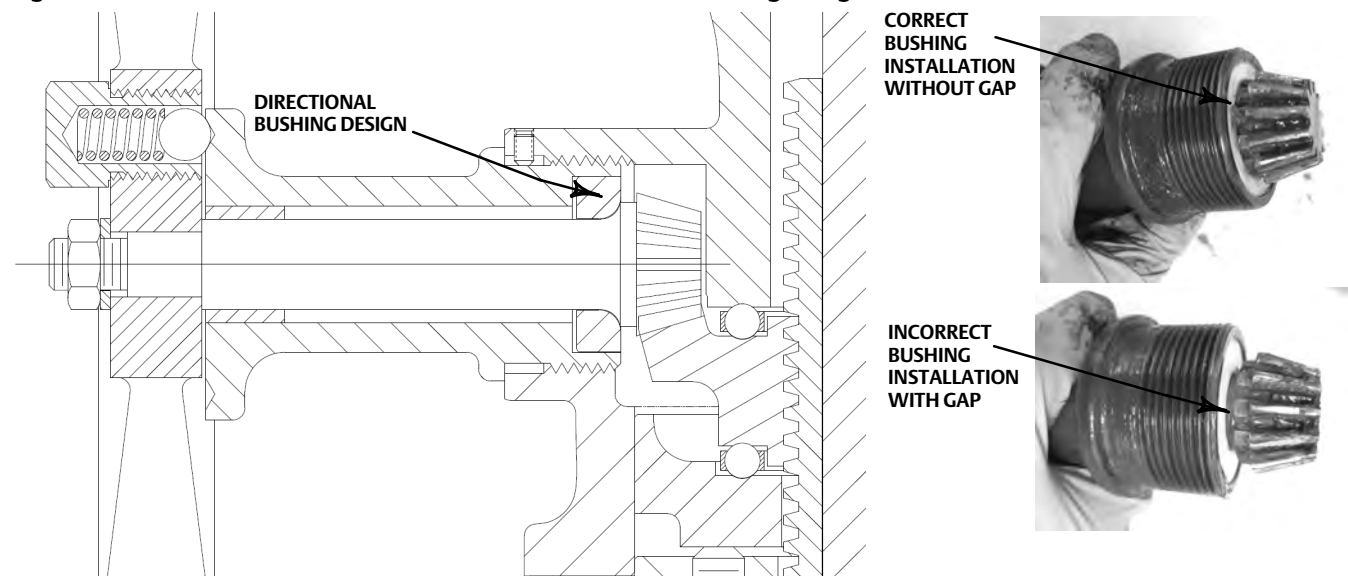

6. Remove the cap screws (key 2) holding the cylinder flange (key 100) to the yoke (key 6).
7. Lift the cylinder flange (key 100) off the yoke (key 6).
8. Inspect the handwheel bearing retainer (key 113), bevel gear (key 114) and thrust bearing (key 115). Replace damaged parts as needed.
9. To remove the actuator stem (not shown), loosen the stem connection (key 12) and pull the actuator stem out the top of the sleeve assembly (key 104).
10. Remove the sleeve by screwing it out of the sleeve assembly (key 104).
11. Unscrew the seal bushing (key 110) to inspect the O-rings (keys 9 and 27).

Disassembly of Handwheel Constructions (Sizes 80-130)

⚠ WARNING

Refer to the WARNING at the beginning of the Maintenance section (Sizes 60-130) in this instruction manual.

To disassemble 585C piston actuators sizes 80-130 (with handwheel) for maintenance, perform the following procedures (figure 12):

1. Be sure that all pressure is out of the cylinder and valve body.
2. Remove all tubing lines to the positioner.
3. Remove the cap screws (key 2) on the underside of the cylinder adapter (key 101) and remove the cylinder (key 1).
4. Remove the piston nut (key 4), then use a mallet to remove the piston (key 3) from the piston connector (key 107).
5. Remove the cap screws (key 127) and cylinder adaptor (key 101).
6. Remove the cap screws (key 128) and remove the spacer (key 102), being careful not to lose the key (key 144).
7. Remove the locking pin (key 131), disconnect the stem connector (key 12) and pull out the actuator stem.
8. Remove the pointer (key 129) and turn the sleeve out of the sleeve assembly (key 104).
9. Remove the cap screws (key 128) holding the gear case (key 103) to the yoke (key 6).
10. Lift the gear case (key 103) to expose the handwheel assembly.

Reassembly (Sizes 60-130)

When reassembling the 585C piston actuator with side-mounted handwheel, adjust the setscrew (key 125) to eliminate play in gear bearings. When properly set, lock with key 126.

When reassembling the side mounted handwheel, all parts required lubrication as shown in per figure 10, 11, 12, and 13 should be fully lubricated.

When reassembling the actuator after the piston nut (key 4) has been removed from the piston connector (key 107), clean the threads of the piston nut thoroughly and apply thread sealant to the threads. Tighten the piston nut securely to a torque of 237 N•m (175 lbf•ft) for size 60 actuators, 1290 N•m (950 lbf•ft) for size 68, 80, and 100 actuators, or 2070 N•m (1530 lbf•ft) for size 130 actuators.

Parts Ordering

When corresponding with your [Emerson sales office](#) about this equipment, refer to the serial number found on the actuator nameplate (key 21).

⚠ WARNING

Use only genuine Fisher replacement parts. Components that are not supplied by Emerson should not, under any circumstances, be used in any Fisher valve, because they may void your warranty, might adversely affect the performance of the valve, and could cause personal injury and property damage.

Parts Kits

Table 12. Standard Construction

Actuator Size	Parts Kit Description	Parts Kit Number
25	O-ring (contains keys 7, 8, and 9)	R585CX00252
50	Backup ring (key 25) for size 50 actuators only	R585CX00502
60 (2-inch maximum travel)	O-ring (contains keys 7, 8, 9, and 27) Piston rod boot (key 29) and Snap ring (keys 30 and 31)	R585CX00012
60 (4-inch maximum travel)	O-ring (contains keys 7, 8, 9, and 27) Piston rod boot (key 29) and Snap ring (keys 30 and 31)	R585CX00022
60 (2-, 4-, and 8-inch maximum travel w/ handwheel) (8-inch maximum travel)	O-ring (contains keys 7, 8, 9, and 27)	R585CX00032
68 (2-, 4-, and 8-inch maximum travel w/ handwheel)	O-ring (contains keys 7, 8, 9, 27, and 112)	R585CX00102
68 (2-, 4-, and 8-inch maximum travel) 80 (8-inch maximum travel) 80 (2-, 4-, and 8-inch maximum travel w/ handwheel)	O-ring (contains keys 7, 8, 9, and 27)	R585CX00042
80 (4-inch maximum travel)	O-ring (contains keys 7, 8, 9, and 27) Piston rod boot (key 29) and Snap ring (keys 30 and 31)	R585CX00052
100 (4-inch maximum travel)	O-ring (contains keys 7, 8, 9, and 27) Piston rod boot (key 29) and Snap ring (keys 30 and 31)	R585CX00062
100 (8-inch maximum travel) 4- and 8-inch maximum travel w/ handwheel)	O-ring (contains keys 7, 8, 9, and 27)	R585CX00072
130 (4-inch travel)	O-ring (contains keys 7, 8, 9, and 27) Piston rod boot (key 29) and Snap ring (keys 30 and 31)	R585CX00082
130 (8-inch travel) (4- and 8-inch travel with handwheel)	O-ring (contains keys 7, 8, 9, and 27)	R585CX00092

Table 13. Low Ambient Temperature Construction

Actuator Size	Parts Kit Description	Parts Kit Number
60 (2, 4 and 8-inch maximum travel) 60 (2,4 and 8-inch maximum travel w/ handwheel)	O-ring (contains key 7, 8, 9 and 27) lubricant (key 24)	R585CF00012
68 (2, 4 and 8-inch maximum travel) 68 (2, 4 and 8-inch maximum travel w/ handwheel) 80 (2, 4 and 8-inch maximum travel) 80 (2, 4 and 8-inch maximum travel w/ handwheel)	O-ring (contains key 7, 8, 9 and 27) lubricant (key 24)	R585CF00022
100 (4 and 8-inch maximum travel)	O-ring (contains key 7, 8, 9 and 27)	R585CF00032
130 (4 and 8-inch maximum travel) 130 (4 and 8-inch maximum travel w/ handwheel)	O-ring (contains key 7, 8, 9 and 27) lubricant (key 24)	R585CF00042

Parts List

Note

Contact your [Emerson sales office](#) for Part Ordering information.

Sizes 25 and 50

Common Actuator Parts (figure 5 or 7)

Key	Description
1	Cylinder
2	Cylinder-to-Yoke Bolts
3	Piston
4	Cap Screw, for actuators without handwheel
5	Travel Stop Spacer
6	Yoke
7*	Yoke O-ring
8*	Piston O-ring
9*	Actuator Stem O-ring
10	Actuator Stem
11*	Piston Stem Bearing
12	Stem Connector
13	Stem Connector Nut
14	Cap Screw (2 req'd)
15	Hex Nut
16	Bias Spring, outer (see table 4-7 for use)
17	Bias Spring, inner (see table 4-7 for use)
18	Self Tapping Screw (2 req'd)
19	Travel Indicator Scale
20	Drive Screw (7 req'd)
21	Nameplate
22	Warning Tag
23	Hex Nut (2 req'd)
24	Lithium grease (not furnished with actuator)
25*	Back-Up Ring, Size 50 only
71	Warning Nameplate
75	Spacer (2 req'd)

Additional Parts for Actuator with Handwheel (figure 6, 8, or 9)

Key	Description
1	Cylinder,
35	Neutral Indicator Cover
36	Handwheel Housing
37	Neutral Indicator Plate
38	Bearing Cover
39	Thrust Bearing
40	Anti-rotation Key
42	Neutral Indicator
43	Neutral Indicator Plate Screw (2 req'd)
45	Handwheel Stem Washer
46	Operating Nut
47	Handwheel
48	Handwheel Retaining Ring
50	Grease Fitting
51	Bearing Cover Set Screw (3 req'd)
52	Handwheel Jam Nut
53	Button Plug
56	Handwheel Stem
57*	Cylinder Cover O-Ring - For Push Only
58*	Handwheel Housing O-Ring - For Push Only
60	Handwheel Stem Cap Screw, (4 req'd for size 25), (3 req'd for size 50)
63	Detent Spring
64	Detent Ball
65	Locking Key
66	Bypass Valve
67	Bypass Tubing
68	Bypass Tee
69	Piston Stud
70	Thread locking adhesive (medium strength) (not furnished with actuator)
72	Hex Nut, Slotted
73	Cotter Pin
74	Elbow, Tube

Figure 5. Fisher 585C Size 25 and 50 Actuators (spring retracts actuator rod)

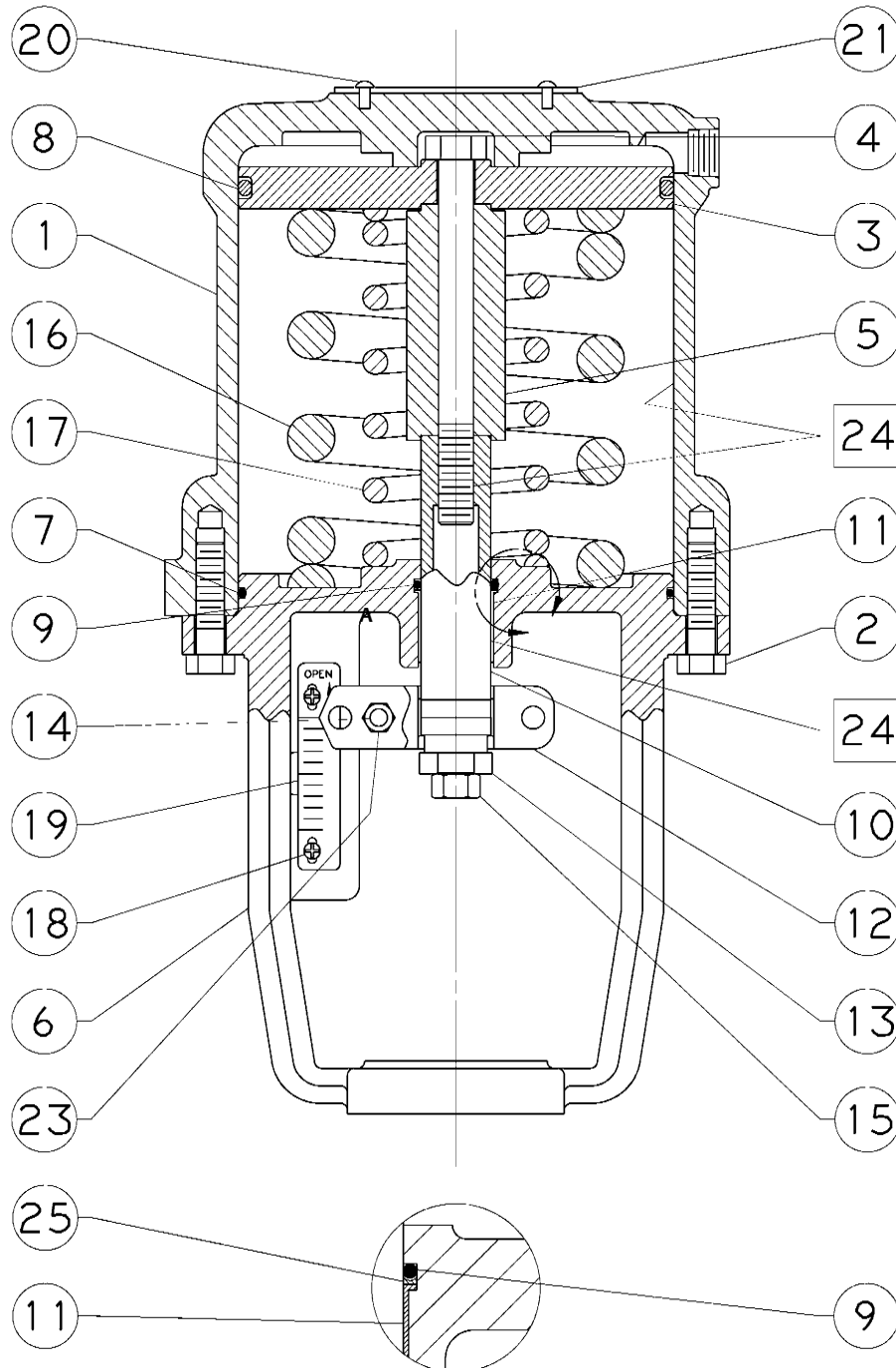

□ APPLY LUB
NOTE:
KEY NUMBERS 22 AND 71 NOT SHOWN

4486335-C

Figure 6. Fisher 585C Size 25 and 50 Actuators Handwheel Assembly (spring retracts actuator rod)

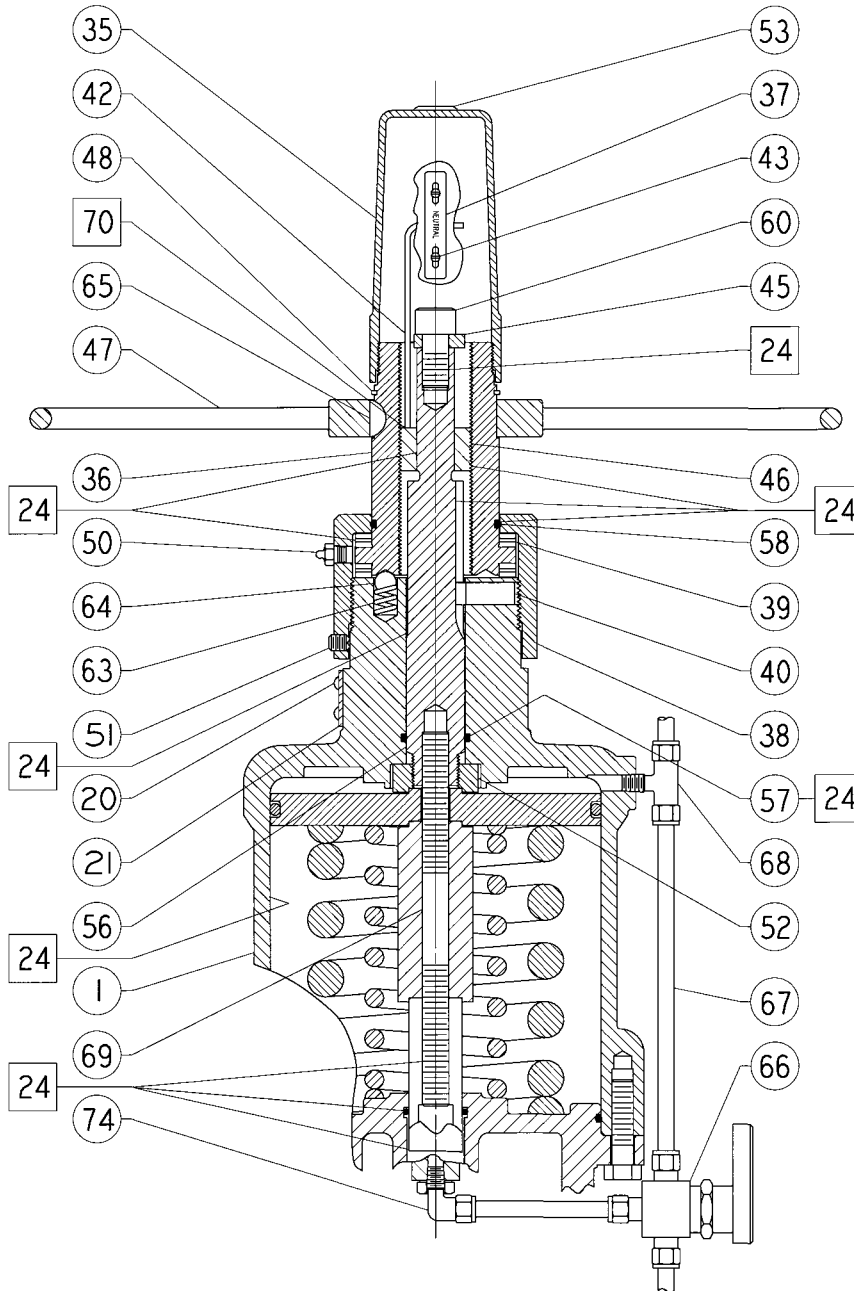

□ APPLY LUB

4486330-B

HANDWHEEL ASSEMBLY

Figure 7. Fisher 585CR Size 25 and 50 Actuators (spring extends actuator rod)

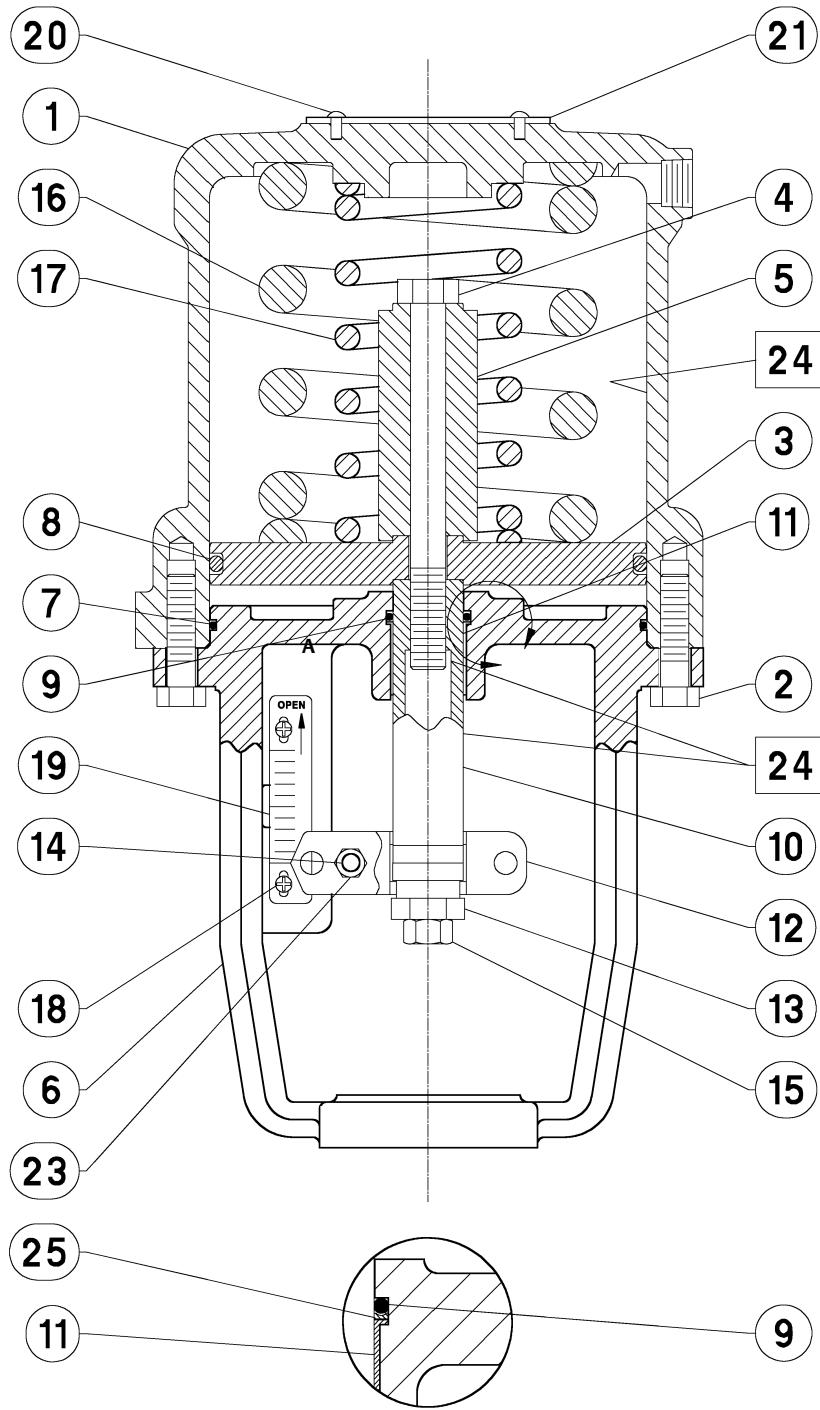

□ APPLY LUB
NOTE:
KEY NUMBERS 22 AND 71 NOT SHOWN

4486319-D

Figure 8. Fisher 585CR Size 25 and 50 Actuators Handwheel Assembly (spring extends actuator rod)

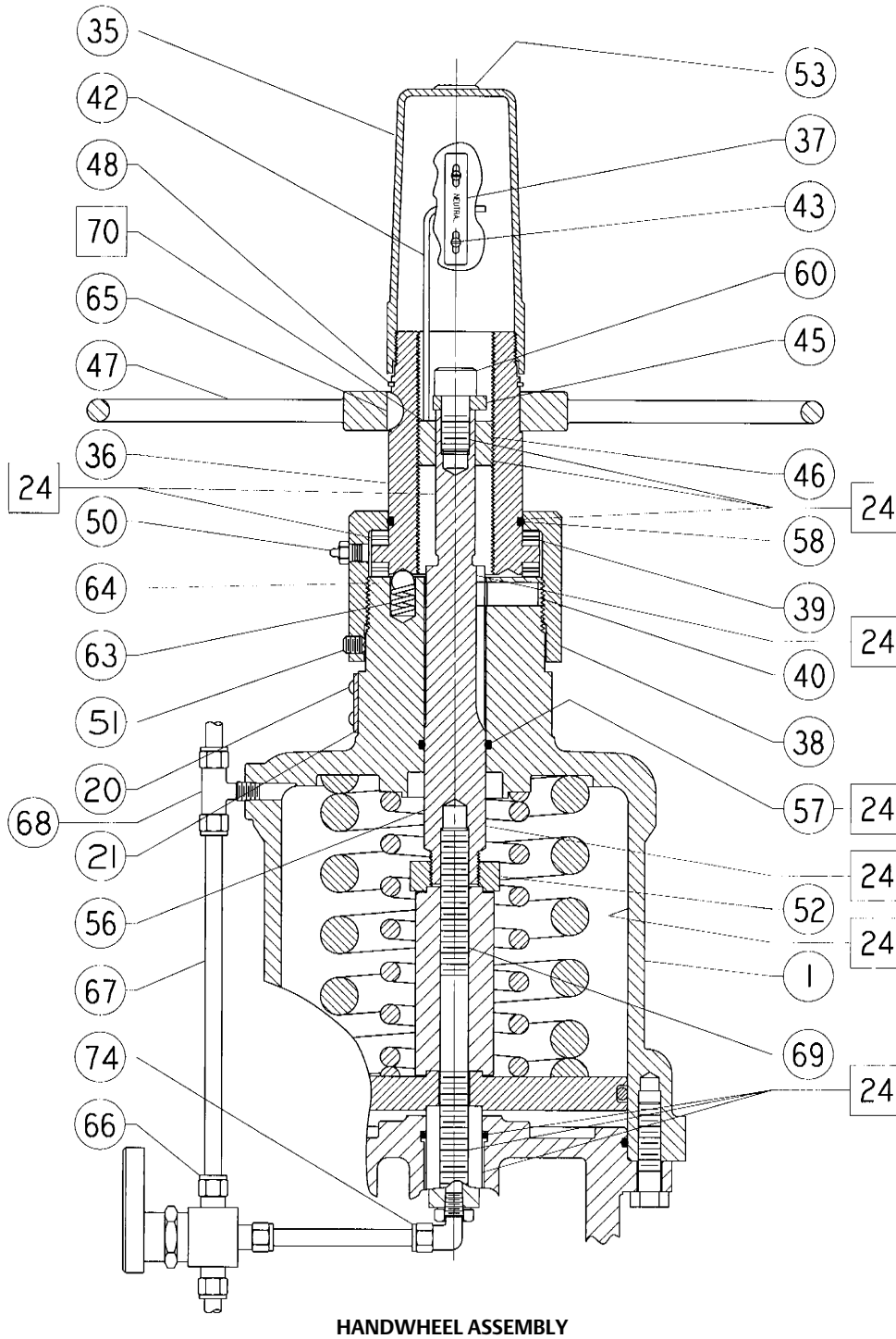

□ APPLY LUB, SEALANT

4486337-C

Figure 9. Fisher 585C Size 25 and 50 Actuators Handwheel Assembly—Direct Acting, Push Only
(spring retracts actuator rod)

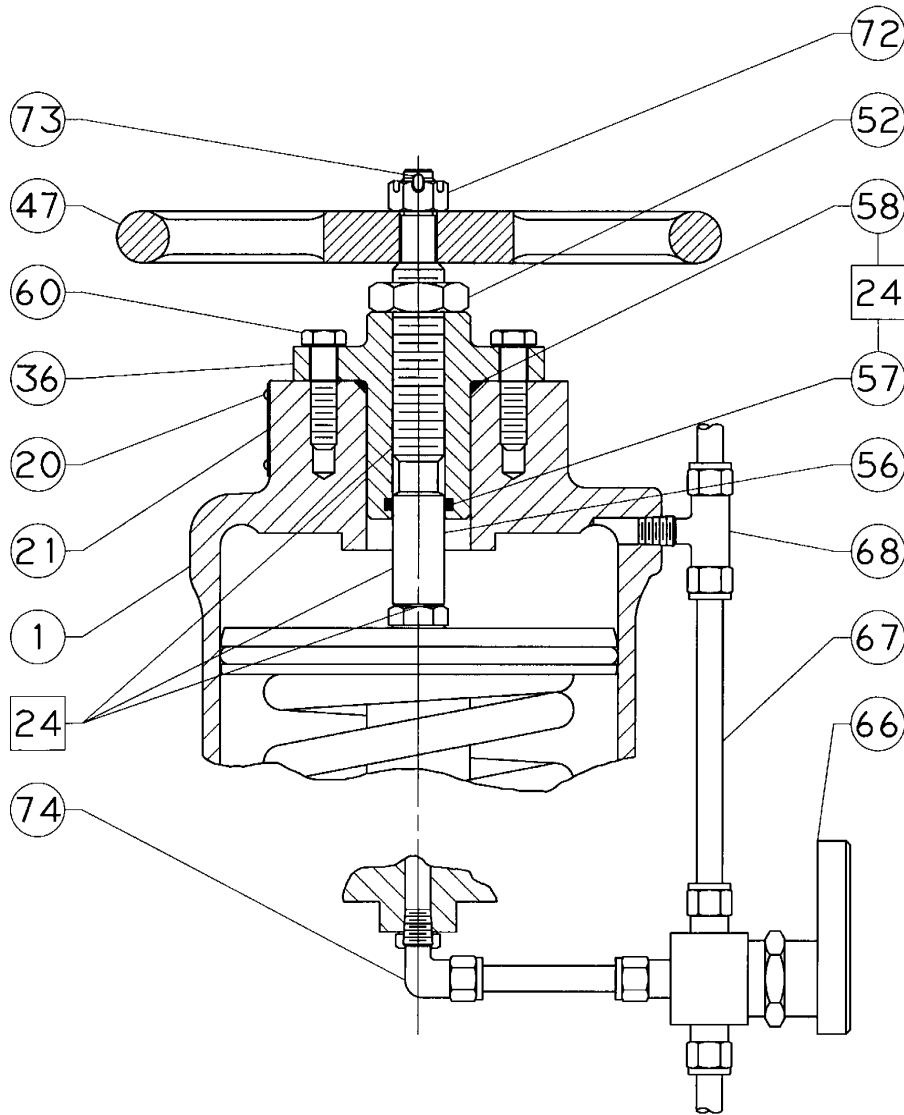

HANDWHEEL ASSEMBLY

□ **APPLY LUB**

3488587-B

Sizes 60-130 (figures 10-16)

Key	Description	Key	Description
1	Cylinder Assembly	106	Actuator Stem
2	Cap Screw	107	Piston Connector
3	Piston	108	Piston Ring Adaptor
4	Piston Nut	109	Washer
6	Yoke	110*	Seal Bushing (with handwheel)
7*	O-Ring	111	Retaining Ring
8*	O-Ring	112*	O-Ring
9*	O-Ring	113	Bearing Retainer
10	Actuator Stem	114	Bevel Gear
12	Stem Connector Assembly	114	Worm Gear
15	Hex Nut	115	Thrust Bearing (2 req'd)
18	Screw (2 req'd)	116	Bevel Pinion
19	Travel Indicator Scale	116	Worm Shaft
20	Drive Screw	117	Extension
21	Nameplate	118	Handwheel
22	Warning Nameplate (not shown)	119	Handwheel Cap
24	Lithium grease for standard service and for handwheel locations in all services (not furnished with actuator)	119	Hex Nut (1 req'd)
24	Krytox GPL 202 for cylinder and o-ring locations for low ambient temperature service (not furnished with actuator)	120	Lockwasher
26*	Seal Bushing (without handwheel)	121	Spring Cap
27*	O-Ring	122	Spring
28*	Wiper Scraper	123	Ball
29*	Piston Rod Boot	123	Cover Screw
30*	Snap Ring	124	Bushing
31*	Snap Ring	125	Set Screw
32	Travel Indicator Disk	126	Hex Nut
33	Twin Speed Nut (not shown)	127	Cap Screw
34	Machine Screw	128	Cap Screw
70	Thread sealant (not furnished with actuator)	129	Pointer
76	Adaptor Flange	130	Handjack Indicator
76	Cylinder Flange	131	Locking Pin
77	Cap Screws	132	Chain
90	Pipe Nipple (not shown)	133	Drive Screw
91	Pipe Tee	134	Ball Bearing
92	Needle Valve	135	Front Worm Retainer
100	Cylinder Flange	136	Back Worm Retainer
101	Cylinder Adaptor	137	Hand Grip
102	Spacer	138	Hand Grip Bolt
103	Gear Case	139	Set Screw
104	Sleeve Assembly	140	Zerk Fitting
105	Sleeve	141	Ring
		142	Machine Screw (2 req'd)
		143	Key
		144	Key
		145	Caution Tag (not shown)
		146	Cable Tie (2 req'd) (not shown)

Figure 10. Fisher 585C Actuator with Integral Handjack Size 68 with 2- and 4-Inch Travel

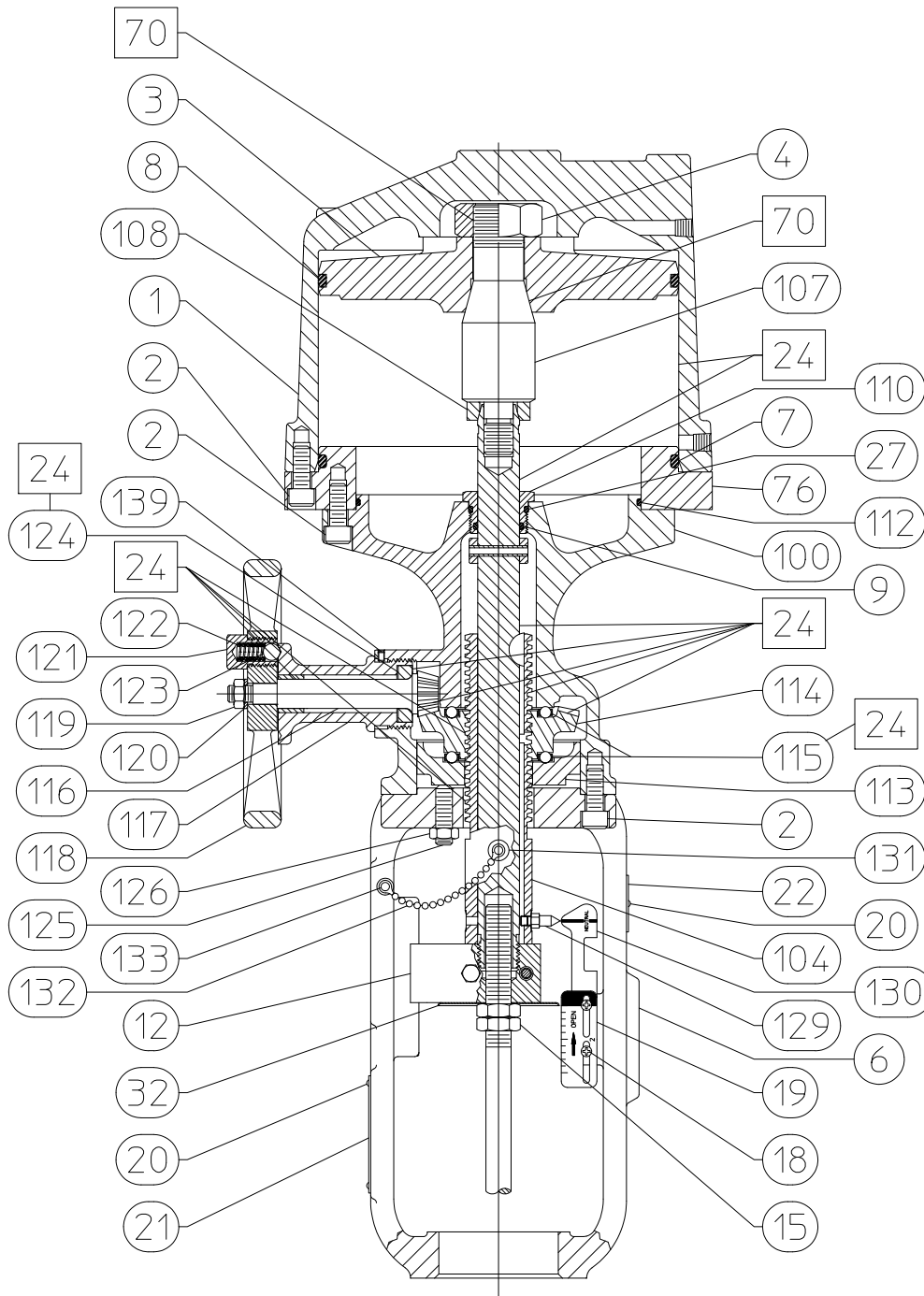

□ APPLY LUB/SEALANT
PARTS NOT SHOWN: 33, 145, 146
FOR BYPASS ASSEMBLY, SEE FIGURE 16
GH17769_A

Figure 11. Fisher 585C Actuator with Integral Handjack Size 60 with 8-Inch Travel

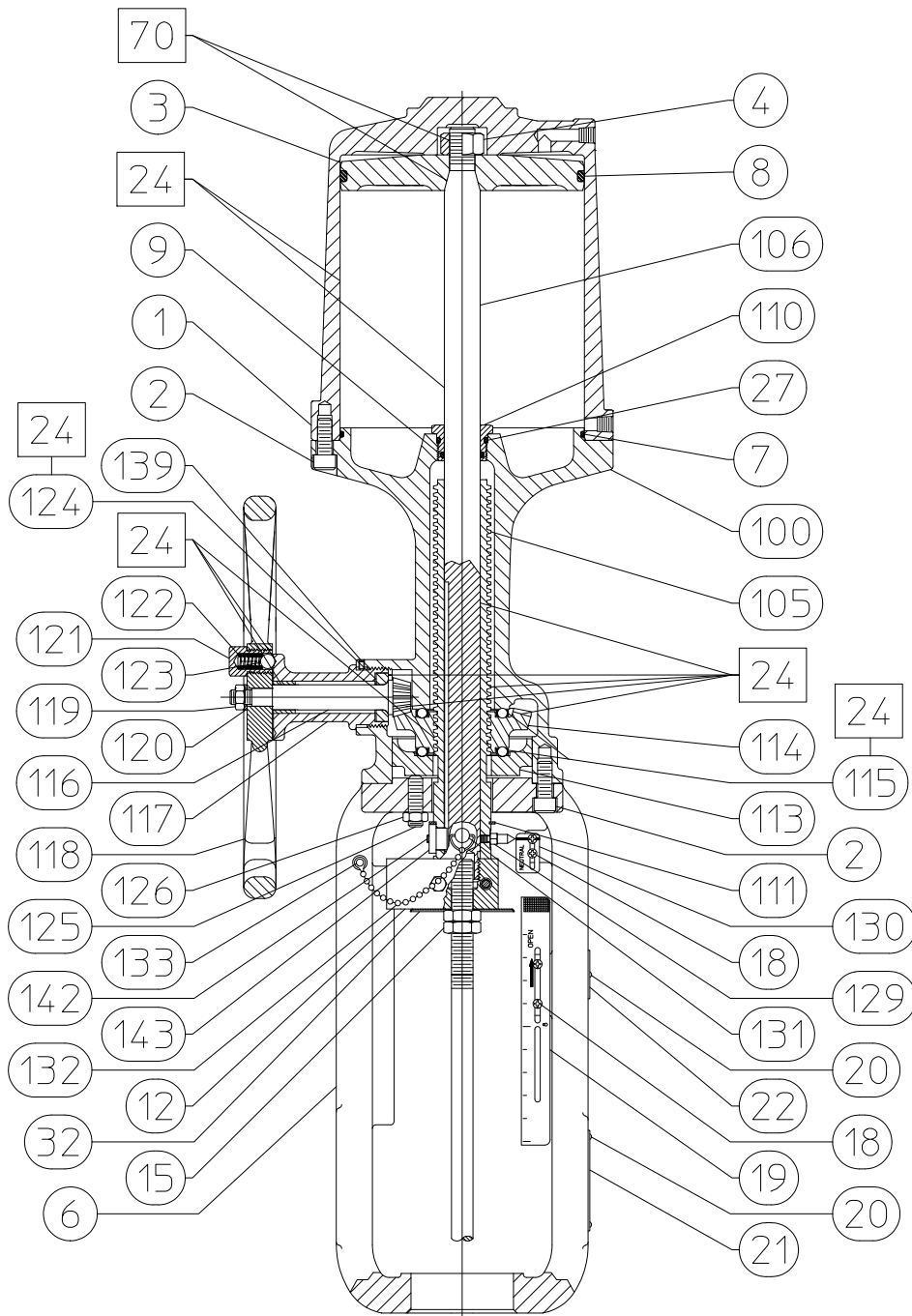

□ APPLY LUB/SEALANT
PARTS NOT SHOWN: 33, 141, 145, and 146
FOR BYPASS ASSEMBLY, SEE FIGURE 16
GH17700

Figure 12. Fisher 585C Actuator with Integral Handjack Size 80 and 100 with 4-Inch Travel

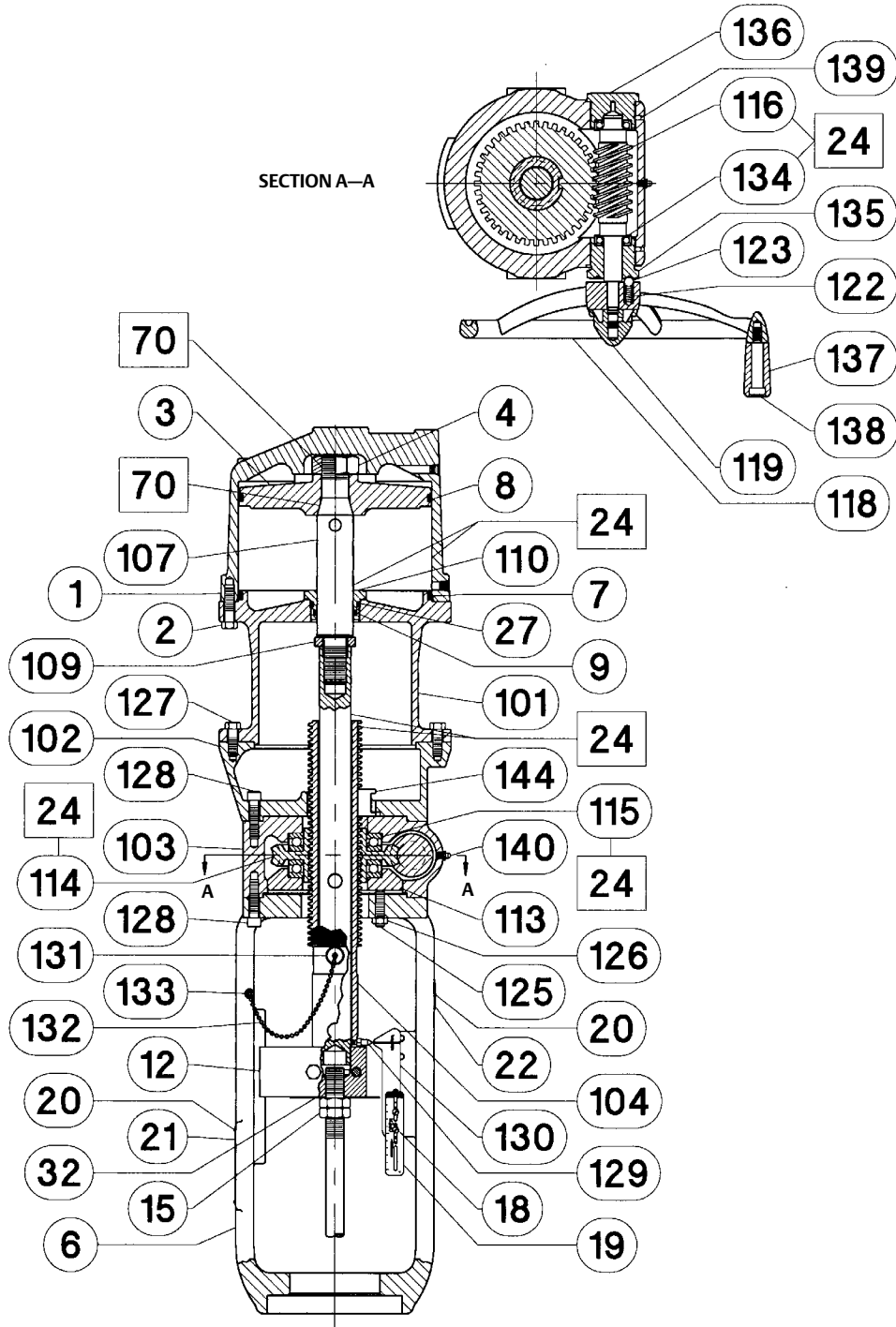

□ APPLY LUB/SEALANT
PARTS NOT SHOWN: 141, 145, 146
FOR BYPASS ASSEMBLY, SEE FIGURE 16

58B1373-A

Figure 13. Fisher 585C Actuator with Integral Handjack Size 130 with 4-Inch Travel

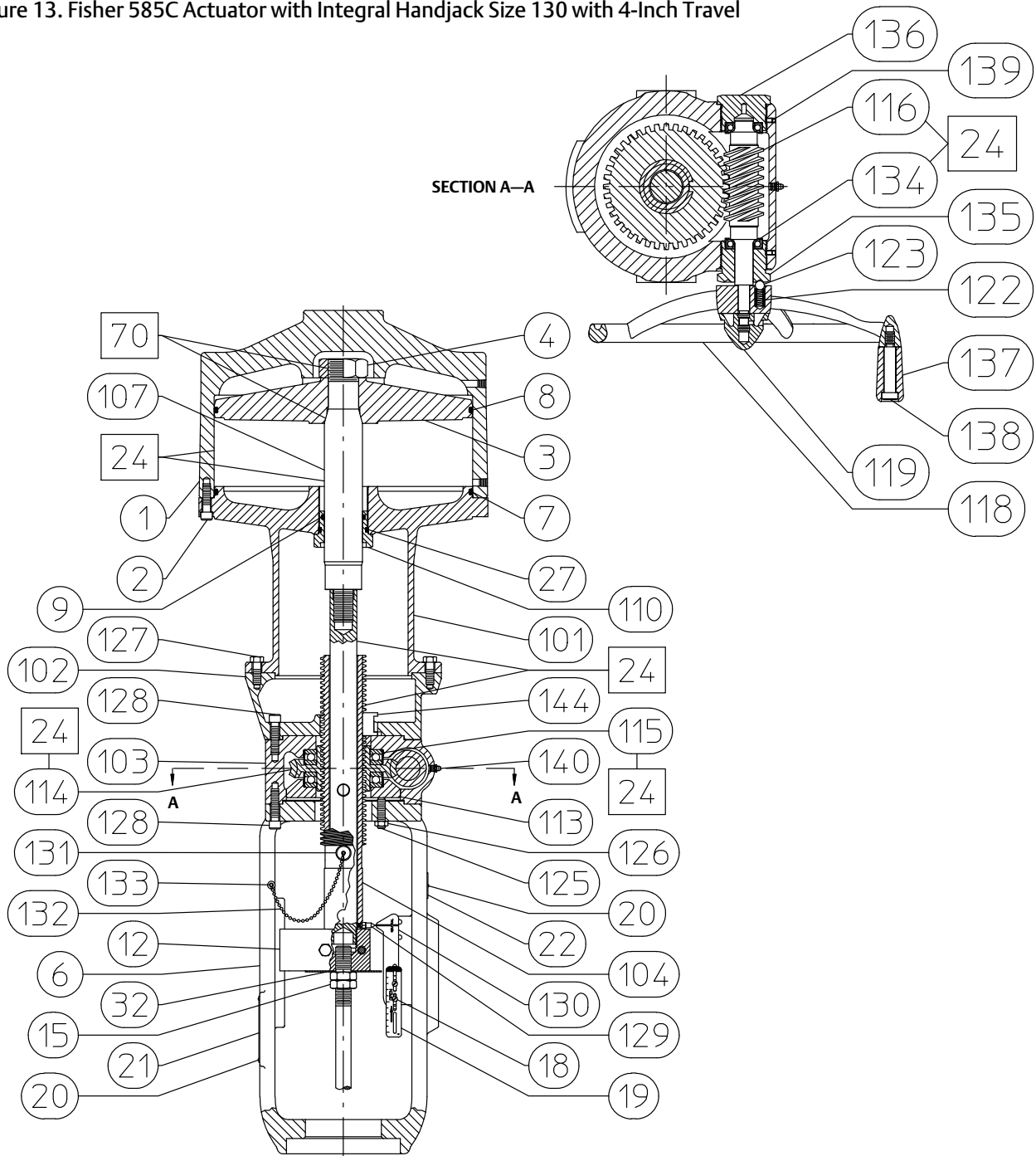

□ APPLY LUB/SEALANT

PARTS NOT SHOWN: 141, 145, 146
FOR BYPASS ASSEMBLY, SEE FIGURE 16

58B1375-1
58B1378-2

Figure 14. Fisher 585C Actuator Size 60 with 2- and 4-Inch Travel

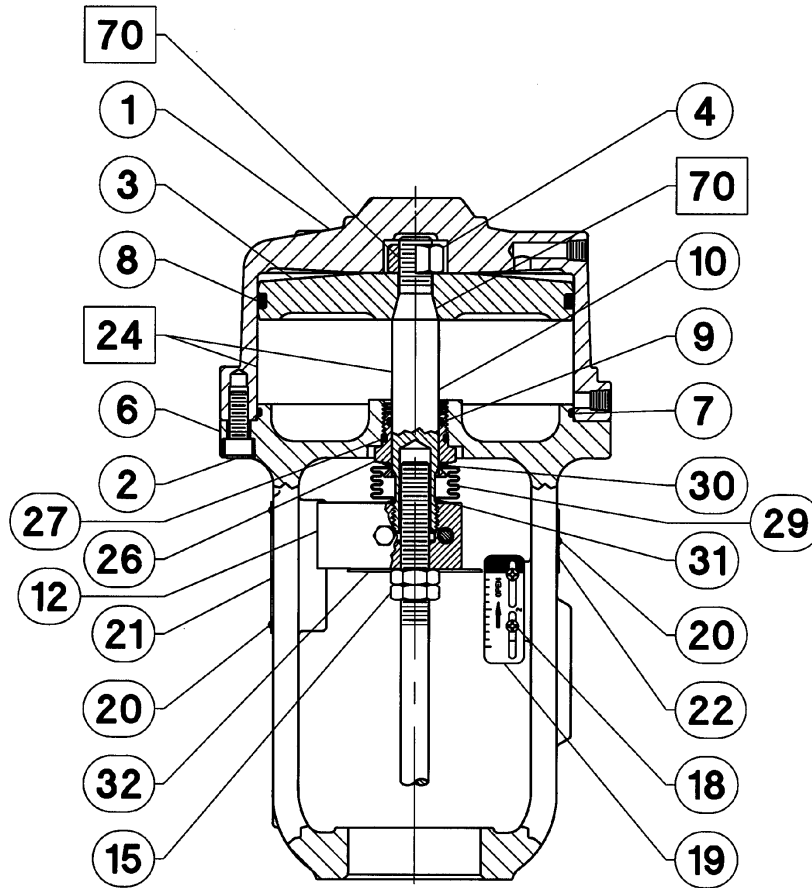

□ APPLY LUB/SEALANT
PARTS NOT SHOWN: 33

Figure 15. Fisher 585C Actuator Size 60 with 8-Inch Travel and Size 68 with 2-, 4-, and 8-Inch Travel

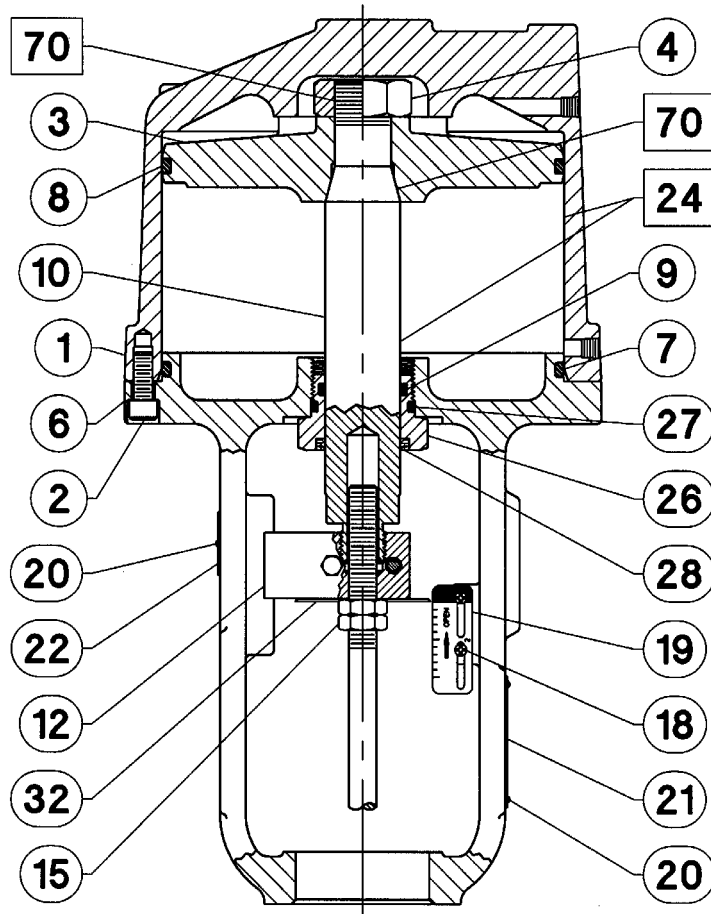

□ APPLY LUB/SEALANT
PARTS NOT SHOWN: 33

58B1366-A

Figure 16. Fisher 585C Size 60-130 Bypass Assembly

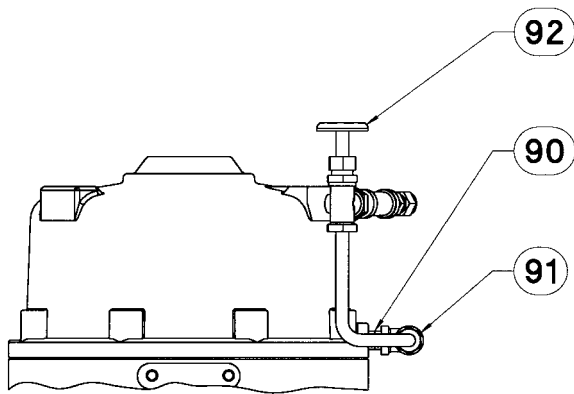

38B1397/A

Neither Emerson, Emerson Automation Solutions, nor any of their affiliated entities assumes responsibility for the selection, use or maintenance of any product. Responsibility for proper selection, use, and maintenance of any product remains solely with the purchaser and end user.

Fisher, FIELDVUE, and TopWorx are marks owned by one of the companies in the Emerson Automation Solutions business unit of Emerson Electric Co. Emerson Automation Solutions, Emerson, and the Emerson logo are trademarks and service marks of Emerson Electric Co. All other marks are the property of their respective owners.

The contents of this publication are presented for informational purposes only, and while every effort has been made to ensure their accuracy, they are not to be construed as warranties or guarantees, express or implied, regarding the products or services described herein or their use or applicability. All sales are governed by our terms and conditions, which are available upon request. We reserve the right to modify or improve the designs or specifications of such products at any time without notice.

Emerson Automation Solutions
Marshalltown, Iowa 50158 USA
Sorocaba, 18087 Brazil
Cernay, 68700 France
Dubai, United Arab Emirates
Singapore 128461 Singapore

www.Fisher.com

