

## Ultrasonic Welding



### *Ultraweld® L20 System*

Emerson's Branson Ultraweld® L20 system is designed and built to assure you the highest degree of reliability and weld quality.

Emerson is the world leader in ultrasonic metal joining through our portfolio of Branson products. We have partnered with industries in many markets including photovoltaic, medical, automotive, battery, refrigeration, electrical and appliance. Our many years of experience have given us a broad base of applications knowledge.

Ultrasonic metal welding provides our customers with a sound solution, superior performance, improved throughput, and reduced maintenance.

Branson welding systems are designed and built to ensure the highest degree of reliability and weld quality.

#### KEY FEATURES:

- **Precision roller bearing slide** assures smooth operation and extreme accuracy
- **Precise adjustments** for accurate setting of both upper and lower positive stops
- **Dovetail mounting** allows quick change fixturing
- **Solid steel horns** for fast set up and minimum tooling cost—or Titanium horns with economical replaceable tips
- **Optional vortex cooling** allows high-speed operation without heat buildup.

# Ultrasonic Welding

ADVANTAGES OF ULTRASONIC WELDING	
Process control	Ultrasonic welding monitored through time, energy, power and height limits
Cost and environmental savings	Elimination of consumables such as solder, flux, crimp connectors and braze materials
Speed	Typical weld cycles under 0.5 seconds
Low operating costs	Less than 1/30 of the energy of resistance welding
Tool life	Precision machined, multi-lobe tools manufactured with high-quality tool steel provide long life, simple setup and precise weld accuracy
Insulation dispersal	In most cases, high frequency scrubbing action eliminates the need to pre-clean parts or strip insulation from magnet wire
Low operating temperature	Minimal heat generation, therefore metal parts will not anneal and there is no need for cooling water
Automation potential	Efficient size, minimal maintenance and orientation flexibility make Branson ultrasonic equipment the best choice for automatic assembly

SPECIFICATIONS	
Frequency	20kHz
Output power	3.3 kW*, 4.0 kW, 5.5 kW
Power supply	220VAC, 50/60 Hz, 30 Amp
Compressed air	80 psi (5.5 bar) clean, dry air

\*3.3 kW output power available only in Asia

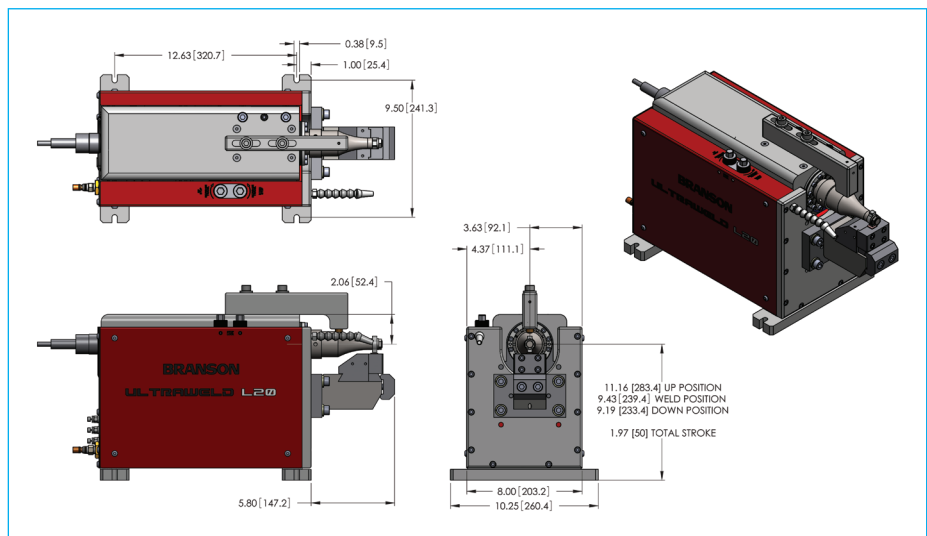

## Americas

Branson Ultrasonics Corp.  
41 Eagle Road  
Danbury, CT 06813-1961  
T: 203-796-0400  
F: 203-796-9838  
[www.Emerson.com/Branson](http://www.Emerson.com/Branson)

## Europe

Branson Ultraschall  
Niederlassung der Emerson  
Technologies GmbH & Co. OHG  
Waldstrasse 53-55  
63128 Dietzenbach, Germany  
T: +49-6074-497-0  
F: +49-6074-497-199  
[www.Emerson.com/Branson](http://www.Emerson.com/Branson)

## Asia

Branson Ultrasonics (Shanghai) Co., Ltd.  
758 Rong Le Dong Road  
Song Jiang, Shanghai, PRC, 201613  
T: 86-21-3781-0588  
F: 86-21-5774-5100  
[www.Emerson.com/Branson](http://www.Emerson.com/Branson)