



YARWAY 7100 SERIES ARC® WITH FILTER INSTALLATION AND MAINTENANCE INSTRUCTIONS

Before installation these instructions must be fully read and understood



either:

1. Keep the main body of valve below 300°F during preheat, welding and post weld heat treatment.
- OR
2. Disassemble the valve to remove seal containing parts (refer to Maintenance section for procedures - disc/bonnet removal and bypass bushing cartridge removal).

Note: failure to follow these precautions will result in damaged seals!

OPERATION

CAUTION!

There are only two adjustments described in the following notes, which can be made to an installed and operating valve. Your valve has been preset and tested at the factory for your conditions. Adjustments are necessary only when conditions change and are not to be made before contacting a Yarway Application Engineer to determine how much adjustment, if any, is necessary. Making adjustments on your own can cause serious damage to the pump and system.

GENERAL

Yarway Series 7100 ARC® Automatic Recirculation Control valve with filter for all filter retrofitted valves and valves Serial No. A71231 and above.

INSTALLATION

General instructions

1. Look at typical installation diagram (see Figure 1).
2. Valve can be installed in any position. However, flow arrow on body must match flow direction in pipe.
3. Valve body material is either carbon steel (ASME-SA 216 WCB) or stainless steel (ASME SA351 CF8M).
Look at the valve nameplate - it will identify the material for your valve!
4. When welding valve in line, select compatible weld rod and follow all applicable codes and regulations.
5. Follow recommendations on installation diagram (opposite page) for straight pipe, maintenance clearances and auxiliary valve locations. Refer to 'ISA handbook of control valves' Chapter 12 for other recommended installation practices.

CAUTION!

The valve you are about to install contains elastomer seals. If welding the valve in line, do one of two things;

1. The 7100 Series valve is a self-contained, fully automatic device which requires no external power or signals to perform its function.
2. The valve does two things: (1) it protects the pump from reverse flow, and (2) prevents the pump from overheating during low load periods.
3. Your valve has a modulating bypass. The bypass will open or close gradually so that the sum of main flow and bypass flow will never be below the minimum flow requirement of the pump.
4. If operating conditions should change, two adjustments can be made in the valve (within limits). They are:
 - a. Switchpoint.
 - b. Bypass capacity.Switchpoint is the main flow quantity at which the bypass will open or close. Bypass capacity is the flow quantity that will pass through the bypass.

YARWAY 7100 SERIES ARC® WITH FILTER

INSTALLATION AND MAINTENANCE INSTRUCTIONS

FIGURE 1

L is recommended minimum straight run of pipe
 $L_1 = 10$ pipe dias. (min.)
 $L_2 = 5$ pipe dias. (min.)
 $L_3 = 5$ pipe dias. (min.)
 e.g. - 4" pipe $L_1 = 40$ in.

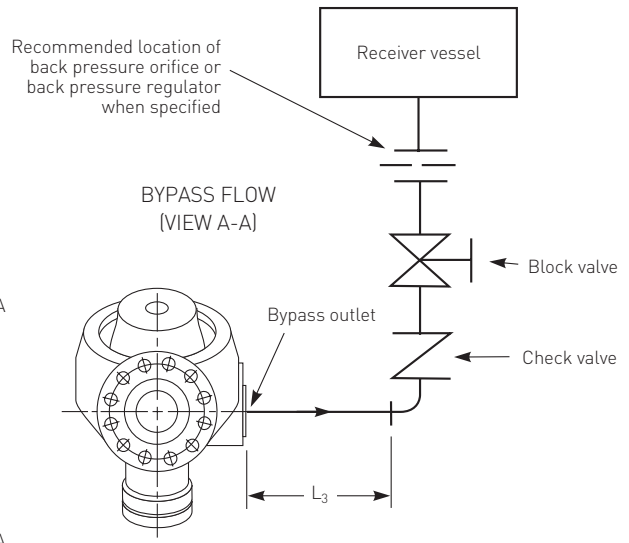
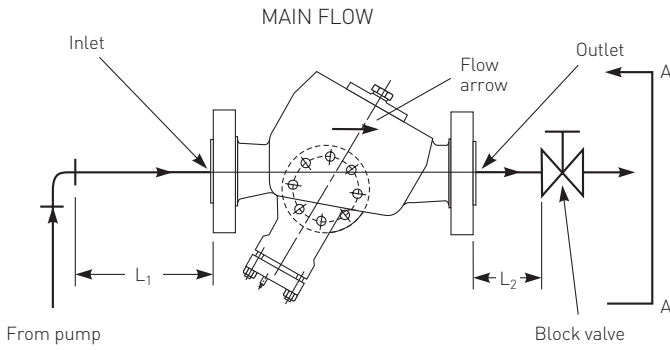

INSTALLATION DIAGRAM

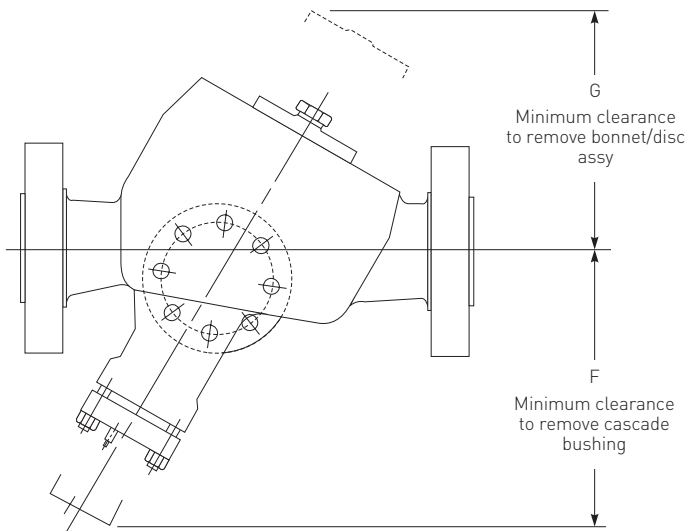

Valve size	F	G
3"	18"	12"
4"	24"	15"
6"	34"	21"
8"	41"	28"

Switchpoint adjustment

CAUTION!

Switchpoint adjustment requires some valve disassembly. Make sure valve is properly isolated, cooled down and all pressure relieved before any work is performed. Follow all applicable safety precautions.

Instructions

1. Switchpoint adjustment can be made by removing either the bonnet/disc assembly or bypass cartridge assembly - to find out how, refer to maintenance section.
2. Look at illustration [see Figure 2].
3. Once the adjustment has been made, refer to maintenance section to reassemble the valve.

YARWAY 7100 SERIES ARC® WITH FILTER

INSTALLATION AND MAINTENANCE INSTRUCTIONS

FIGURE 2

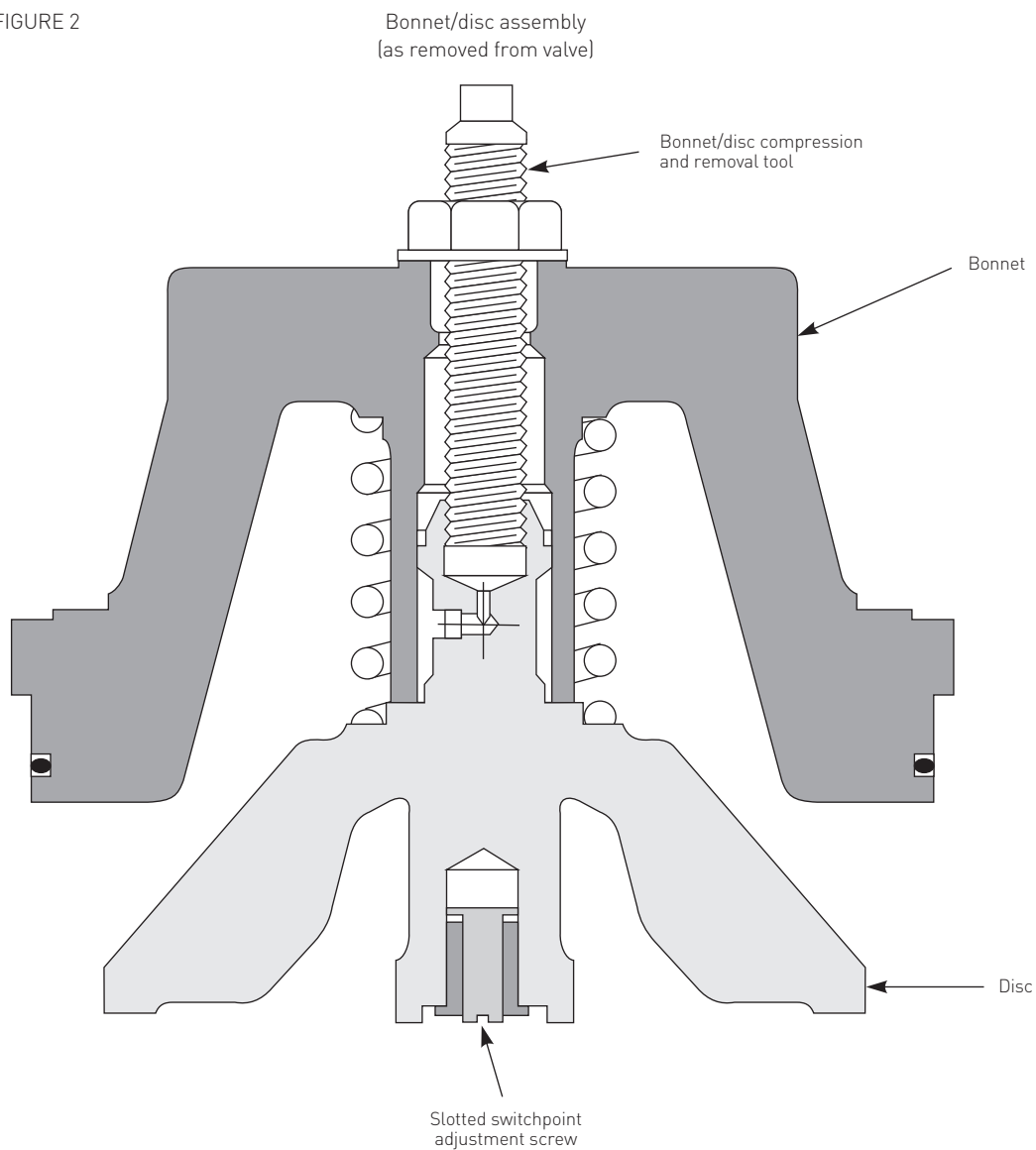

WARNING!

Lowering switch point could damage pump.

To lower switchpoint - turn screw clockwise.

To raise switchpoint - turn screw counterclockwise.

The switchpoint adjustment screw will not turn easily. It is held in place by a friction producing insert which prevents its movement while in service.

YARWAY 7100 SERIES ARC® WITH FILTER

INSTALLATION AND MAINTENANCE INSTRUCTIONS

Bypass capacity adjustment

CAUTION!

This adjustment does not require valve disassembly. However, make sure valve is properly isolated, cooled down and all pressure relieved before any work is performed. Follow all applicable safety precautions.

Instructions

1. Adjustment screw is located at bottom of valve - directly opposite bonnet end.
2. Look at illustration - (see Figure 3).
3. Loosen lock nut, make adjustment, retighten lock nut.

FIGURE 3

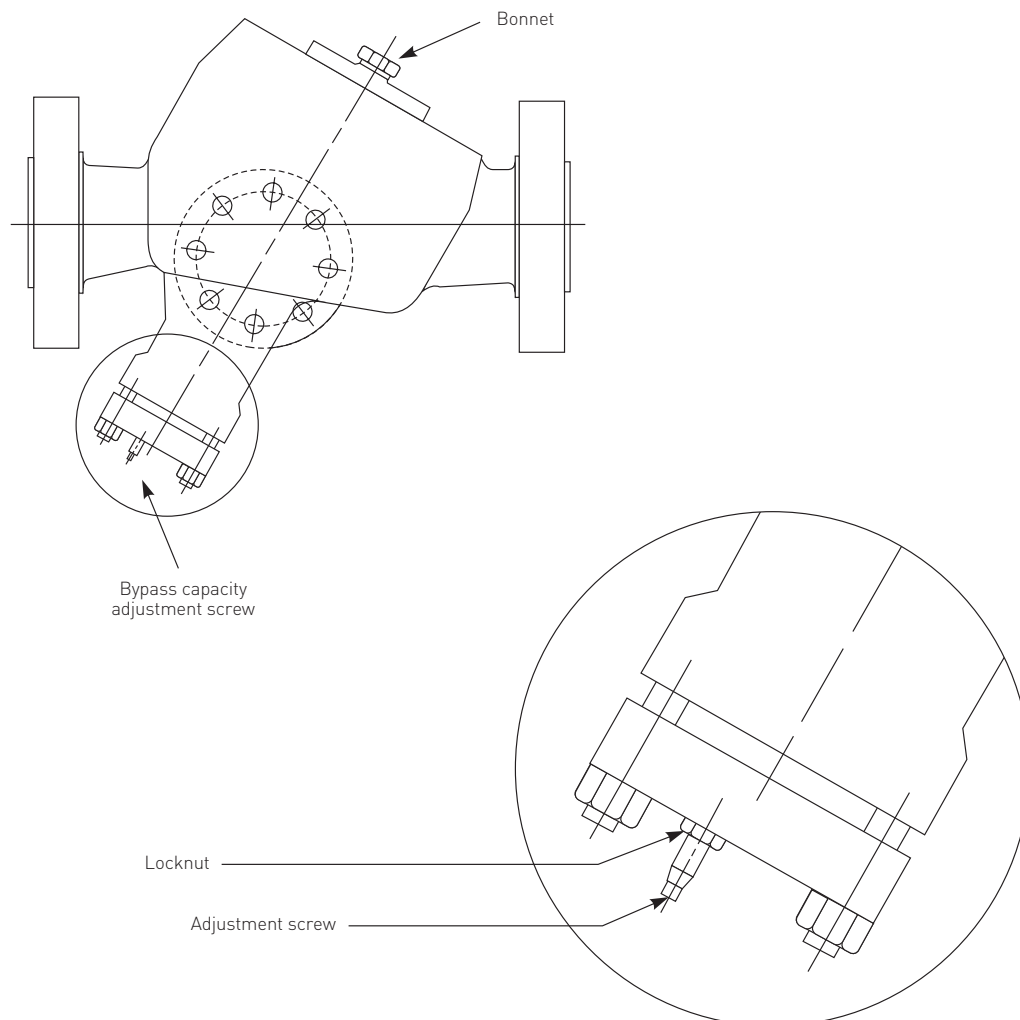

WARNING!

Reducing bypass capacity could damage pump.

To reduce bypass capacity - turn screw clockwise.

To increase bypass capacity - turn screw counterclockwise.

YARWAY 7100 SERIES ARC® WITH FILTER

INSTALLATION AND MAINTENANCE INSTRUCTIONS

FIGURE 4

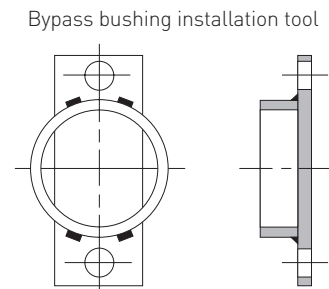
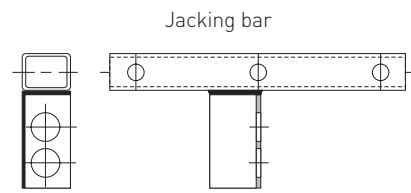
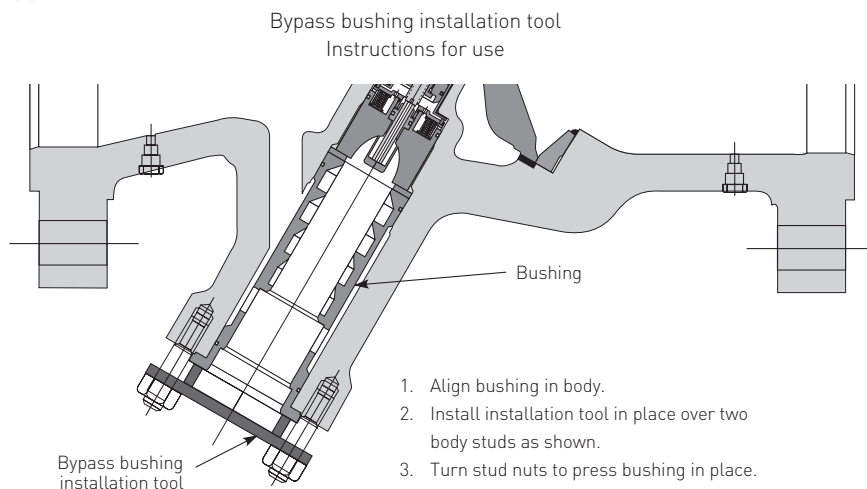

Spring compression tool



Jacking rods



Switchpoint adjustment tool

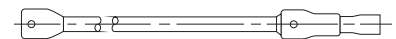

MAINTENANCE

CAUTION!

Make sure valve is properly isolated, cooled down and all pressure relieved before any work is performed. Follow all applicable safety precautions.

General instructions

1. There are only two major disassembly procedures:
 - a. Bonnet/disc removal.
 - b. Bypass cartridge removal.
2. Valve body does not need to be removed from line to perform any maintenance and service procedures.
3. Slightly damaged seating surfaces can be reconditioned by lapping with a fine lapping compound.
4. When changing lip type seals, make sure they are installed in proper direction or the valve won't work properly.

Jacking bar - used to assist removal of bonnet/disc assembly. Complete with lifting lug for support of assembly upon removal. See bonnet/disc removal procedure for instruction.

Bypass bushing installation tool - used with body studs and nuts to assist installation of bushing in body (overcome friction of O-rings). See below for procedure.

Spring compression tool - used to compress disc spring and allow removal of disc/bonnet as a unit. Used with jacking bar. See bonnet/disc removal procedure for instruction.

Jacking rods - used with jacking bar. See bonnet/disc removal procedure for instruction.

Switchpoint adjustment tool - 8" valve only. Used to adjust switchpoint after removal of bypass cartridge (other sizes - use long screwdriver).

YARWAY 7100 SERIES ARC® WITH FILTER

INSTALLATION AND MAINTENANCE INSTRUCTIONS

FIGURE 5

Bonnet/disc assembly parts identification

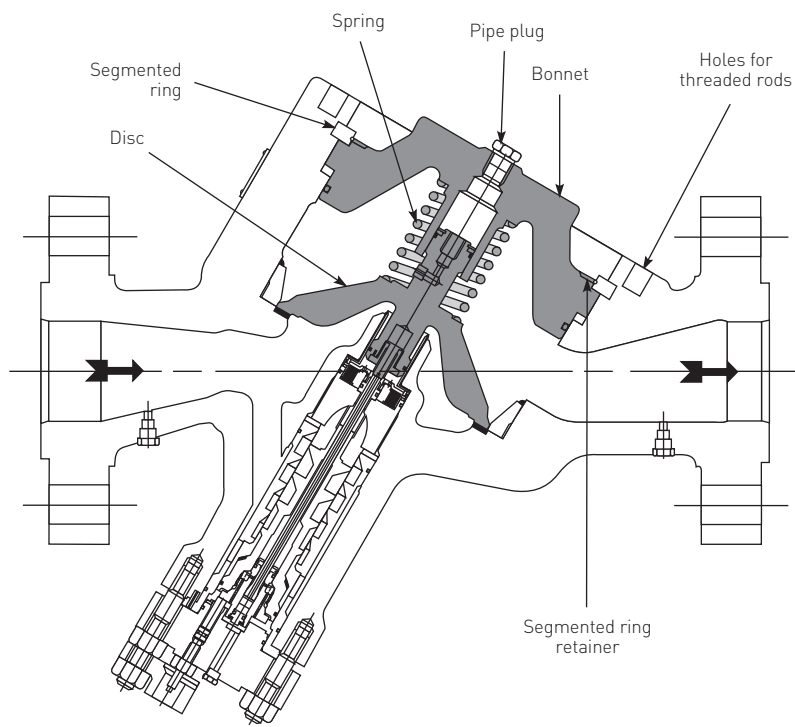

Bonnet/disc removal/installation

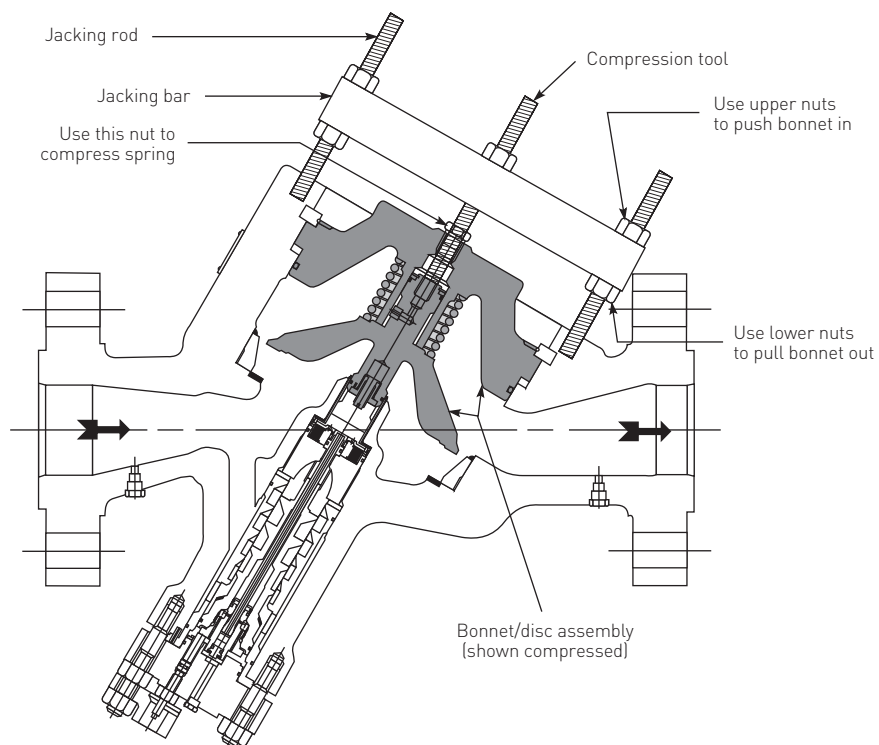

YARWAY 7100 SERIES ARC® WITH FILTER

INSTALLATION AND MAINTENANCE INSTRUCTIONS

Bonnet/disc removal and assembly

Disassembly

1. Look at illustration (see Figure 5).
2. Remove pipe plug.
3. Insert compression tool through the bonnet and screw into disc.
4. Turn nut until disc is in full up position.
5. There are two threaded holes in top of body - use these with jacking rods (can be made from threaded rod) and jacking bar (can be made from appropriate size angle iron or square tube).
6. Using jacking bar, push bonnet into body approximately $\frac{1}{8}$ ".
7. Remove segmented ring retainer.
8. Remove segmented rings.
9. Using jacking bar, pull bonnet/disc assembly out of valve.

Assembly

1. Bonnet and disc must be installed as a unit - use compression tool to assemble bonnet/spring/disc.
2. Using jacking bar, push bonnet/disc assembly into valve until it stops.
3. Insert segmented rings.
4. Install segmented ring retainer.
5. Using jacking bar, pull bonnet/disc assembly until it is snug against segmented rings.
6. With compression tool in place, turn nut until disc is lowered onto seat, then remove tool from bonnet.
7. Replace pipe plug.

YARWAY 7100 SERIES ARC® WITH FILTER

INSTALLATION AND MAINTENANCE INSTRUCTIONS

FIGURE 6

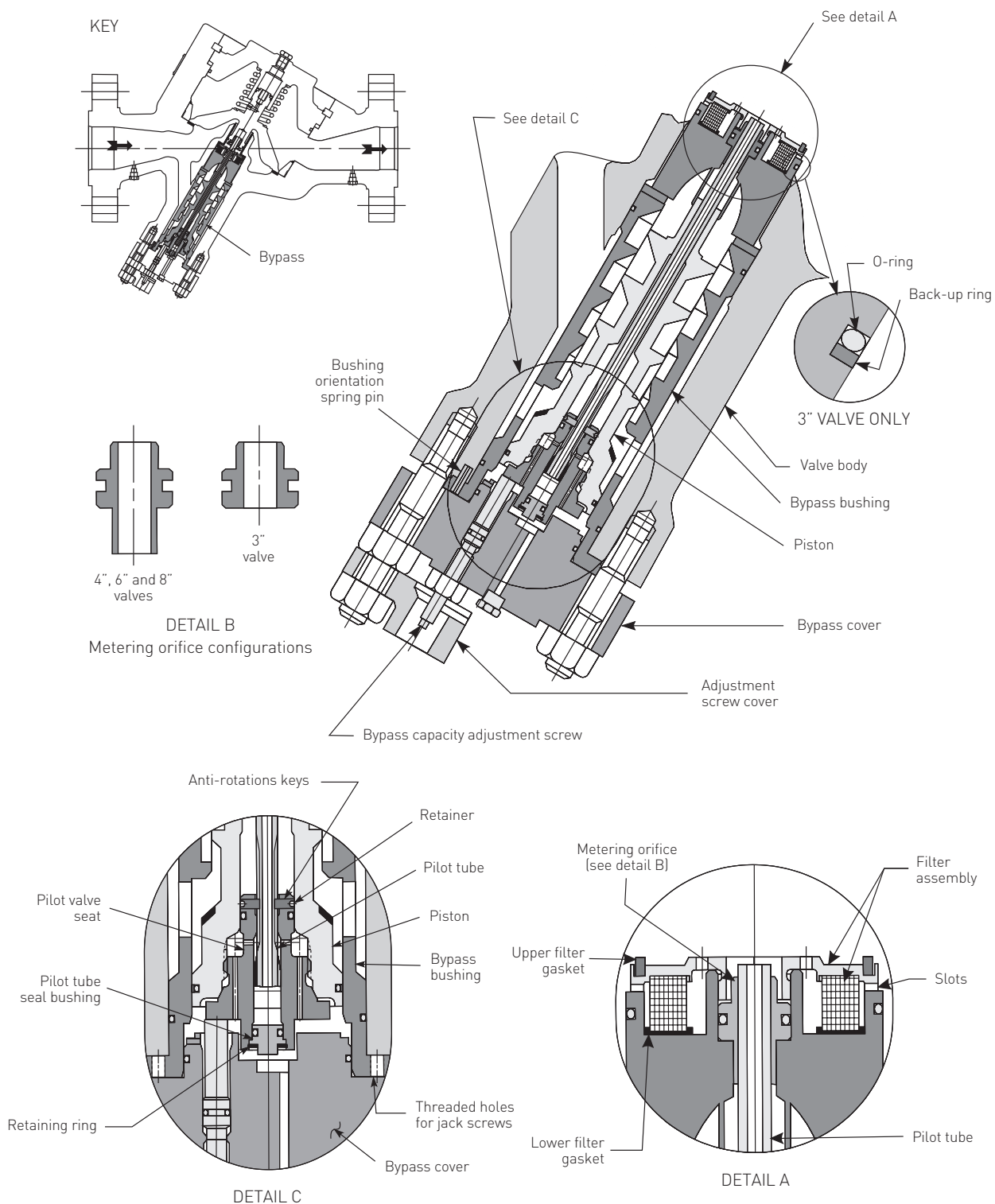

YARWAY 7100 SERIES ARC® WITH FILTER

INSTALLATION AND MAINTENANCE INSTRUCTIONS

Bypass cartridge removal and assembly

Disassembly

1. Look at illustration (see Figure 6).
2. Remove bypass cover.
3. Insert two jacking screws in threaded holes in bypass bushing flange and jack out cartridge.
Once the bypass cartridge is out, and you've determined which of the two (2) pilot tube designs you have, Detail "C" or Detail "D", complete the disassembly as follows:
Detail "D"
 - a. Pull out piston.
 - b. Screw out pilot tube seal bushing.
 - c. Screw out pilot valve seat.
 - d. Remove the anti-rotation keys retainer.
 - e. Pull out pilot tube.Detail "C"
 - a. Pull out piston.
 - b. Screw out pilot valve seat.
 - c. Remove pilot tube seal bushing retaining ring.
 - d. Pull out pilot tube seal bushing.
 - e. Remove the anti-rotation keys retainer.
 - f. Pull out pilot tube.Then:
 4. Carefully pry off the metering orifice retainer (it is press-fitted in place).
 5. Pull out metering orifice.

Assembly

There are only four very important points:

1. Press fit metering orifice retainer in place over metering orifice.
2. When installed, the flats on pilot tube must line up with flats of anti-rotation keys in pilot valve seat.
3.
 - a. If your assembly matches that shown in Detail "D": securely tighten the pilot tube seal bushing and pilot valve seat into piston.
 - b. If your assembly matches that shown in Detail "C": firmly seat the pilot tube seal bushing into the pilot valve seat and ensure that its retaining ring has clearly snapped into its groove. Securely tighten the pilot valve seat into the piston.
4. Bypass bushing outlet must line up with outlet in body. This is accomplished by turning bushing until spring pin in bushing flange lines up with its matching hole in valve body.

YARWAY 7100 SERIES ARC® WITH FILTER

INSTALLATION AND MAINTENANCE INSTRUCTIONS

FIGURE 7

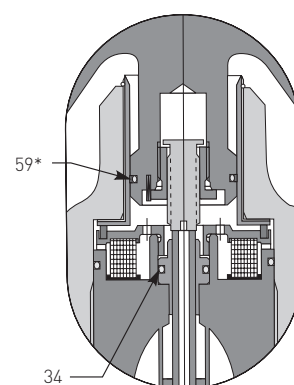
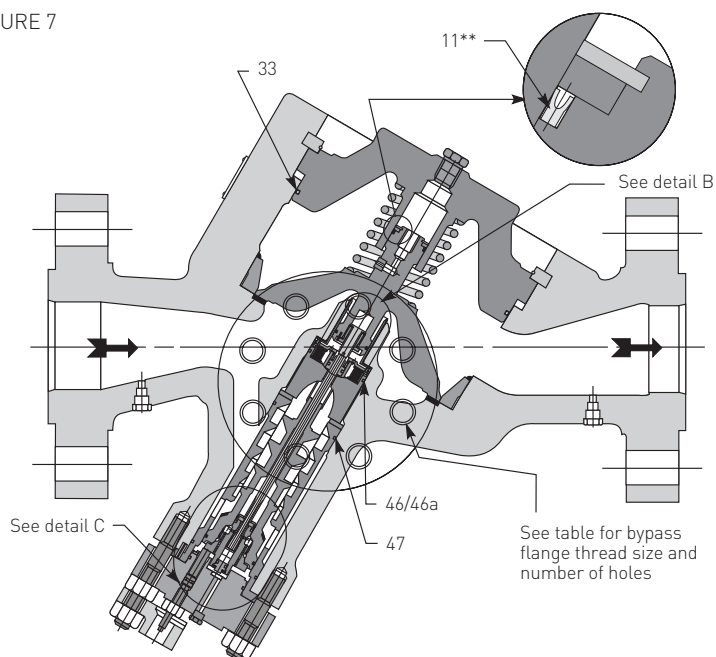

DETAIL B

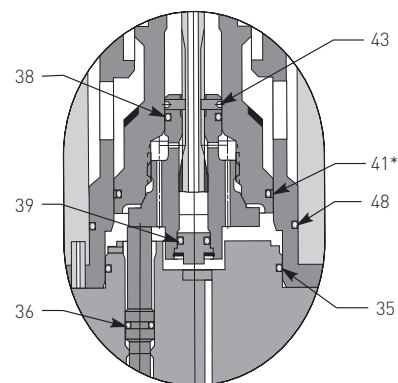

DETAIL C

O-RING SIZES AND BYPASS CONNECTION FLANGE DATA

Item No.	Valve size (O-ring size)			
	3"	4"	6"	8"
33	263	375	456	464
34	014	014	014	014
35	126	139	236	244
36	008	011	113	118
38	014	014	014	014
39	010	010	010	010
43	012	012	012	012
46	028	141	232	238
46a	028 Backup ring	N/A	N/A	N/A
47	131	146	242	354
48	133	147	244	356

BYPASS CONNECTION – THREADED HOLES DATA

Valve size	Bypass size	Class	No. holes	Thread size	Thread depth
3"	1½"	900	4	1"-8UNC	1 13/16"
		1500			
4"	2"	900	8	7/8"-9UNC	1 5/8"
		1500			
6"	2½"	900	8	1"-8UNC	1 13/16"
		1500			
8"	3"	900	8	7/8"-9UNC	1 5/8"
		1500			
			8	1 1/8"-8UN	2"

NOTES

* Glyd ring assembly

** Lip type seal

Contact Yarway with valve serial number to ensure that correct O-ring compound is selected.

YARWAY 7100 SERIES ARC® WITH FILTER
 INSTALLATION AND MAINTENANCE INSTRUCTIONS

FIGURE 8

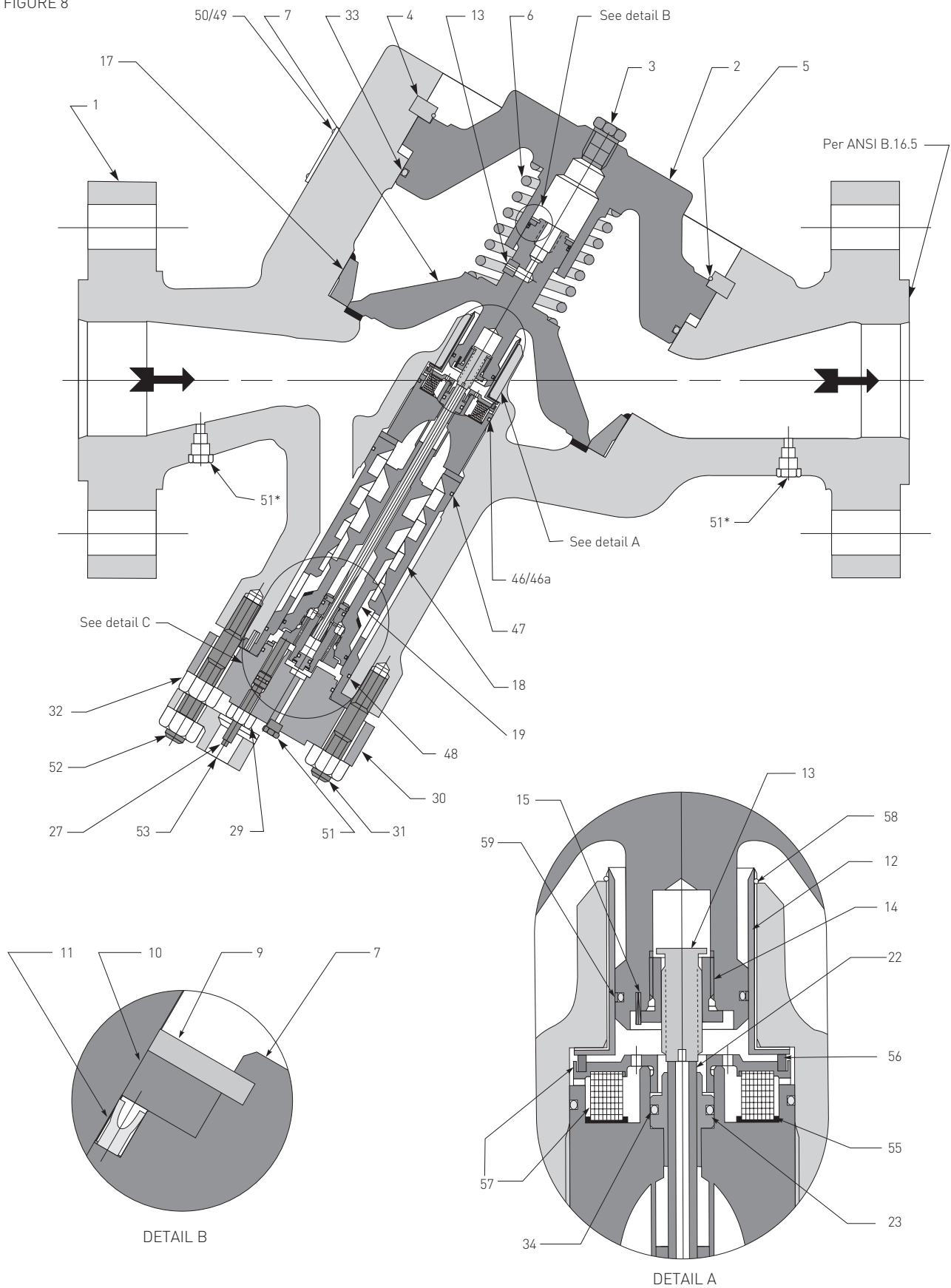

YARWAY 7100 SERIES ARC® WITH FILTER

INSTALLATION AND MAINTENANCE INSTRUCTIONS

PARTS LIST

Item	Description	Item	Description
1	Body	33*	O-ring
2	Bonnet	34*	O-ring
3	Pipe plug	35*	O-ring
4	Segmented retaining ring	36*	O-ring
5	Segmented ring retainer	38*	O-ring
6	Spring	39*	O-ring
7	Disc	41*	Seal assembly
8	Orifice snubber	42*	Anti-rotation keys
9	Retaining ring	43*	Retainer (O-ring)
10	Washer	44*	Pilot valve seat
11*	Seal	45*	Pilot tube seal bushing
12	Disc lower guide bushing	46*	O-ring
13	Switch point adjustment screw	46a*	Back-up ring (3" valve only)
14	Switch point adjustment screw bushing	47*	O-ring
15	Spring pin	48*	O-ring
17	Flow element	49	Drive screws
18•	Bypass bushing	50	Nameplate
19•	Piston	51❖	Pipe plug
22*	Pilot tube	52	Stud
23*	Metering orifice	53	Adjustment screw cover
27	Stroke adjustment screw	55*	Filter gasket, lower
28	Spring pin	56*	Filter gasket, upper
29	Lock nut	57	Filter housing and screen assembly
30	Bypass cover	58	Retaining ring
31	Stud	59*	Seal assembly
32	Nut	60•	Retaining ring

NOTES

- * Recommended spare parts for service and inspection.
- Recommended spare parts for service overhaul.
- ❖ Optional on body.

FIGURE 9

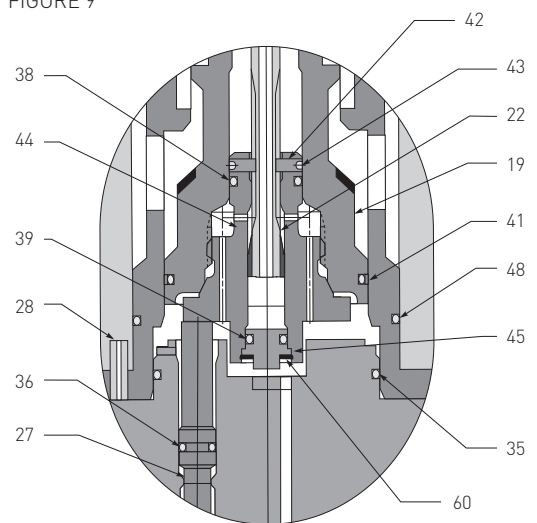

DETAIL C