



## YARWAY BACK PRESSURE REGULATOR 3/4" THRU 6" INSTALLATION AND MAINTENANCE INSTRUCTIONS

Before installation these instructions must be fully read and understood



### PRINCIPALS OF OPERATION

The Back Pressure Regulator (BPR) is used to regulate the outlet pressure from modulating high pressure let-down valves or pump bypass valves when unregulated conditions would cause flashing, cavitation, choked flow and other undesirable two-phase flow effects. Mounted between flanges, the regulator is completely contained within the piping. It consists of a spring-loaded plunger whose motion opens a cylindrical flow passage in the center of the regulator. Flow variations cause the plunger to respond by increasing or decreasing the open flow area. The spring loading is set to maintain the liquid pressure in the line at, or above, the level chosen to prevent cavitation and two-phase flow in the let-down valve and in the piping between the valve and the regulator.

### FEATURES

- Prevents undesirable two-phase flow in piping runs and in modulating valves.
- Reduces cavitation and erosion in high pressure let-down valve trim. Reduces noise level due to those effects.
- Stainless steel construction of all operating parts.
- Installed between flanges; no welding or other procedures or preparation; no external connections.

### SPECIFICATIONS

Line sizes:	3/4", 1 1/2", 2", 3", 4", 6"
Class:	To 1500
Installation:	Inserts into line between flanges
Flange facings:	Facings match the raised face requirements of ANSI B16.5, Class 300 through 1500
Pressure differential:	Selected for the application See nameplate for the operating differential pressure

### STORAGE

Inspect the regulator assembly as received against the purchase specifications. The unit was carefully prepared and supported for shipment. Verify the satisfactory condition of the unit and store it, if necessary, in the shipping container in a dry enclosure.

### UNPACKING

1. Remove from the shipping container.  
If necessary, use a sling around the cylinder.
2. Observe and follow any caution and instruction tags attached to the unit.
3. Protect the surfaces that serve as gasket sealing from scratches, nicks or marks.
4. Inspect for and remove any external or internal shipping restraints.
5. If, for any reason, the regulator has been disassembled, contact Yarway and then if so advised, follow the directions under 'Maintenance' for disassembly and assembly instructions.

# YARWAY BACK PRESSURE REGULATOR 3/4" THRU 6"

## INSTALLATION AND MAINTENANCE INSTRUCTIONS

FIGURE 1

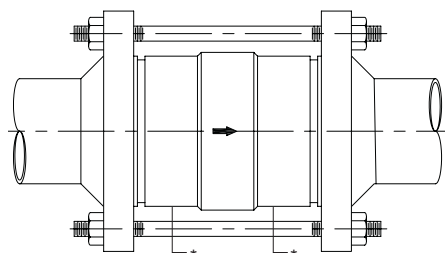

\* Same diameter as raised face to align and center regulator in line except 3/4" size which has raised face.

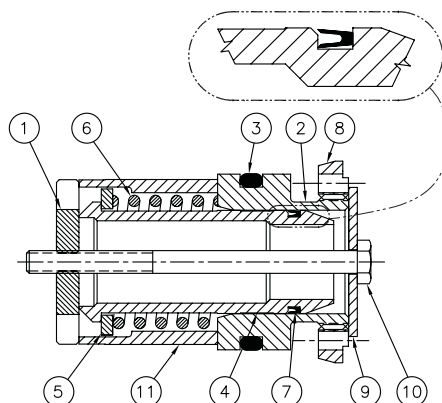

### PARTS LIST

Item	Part
1	Seat
2	Plunger guide
3	O-ring
4	Plunger
5	Spring retainer
6	Spring
7	Seal
8	Retaining ring
9	Washer
10	Draw bolt
11	Spacer

### INSTALLATION

The Back Pressure Regulator is mounted and clamped between flanges. A typical installation is shown in Figure 1. It is important that the regulator be mounted in the correct flow direction; flow arrow is on nameplate. Upstream piping should be flushed to remove all foreign objects before the regulator is installed.

Insert the regulator into the pipe. Support and center the regulator on the raised face on the flanges per Figure 1. Secure the joint using standard assembly procedures.

A pressure tap with a valve and pressure gage, located in the line between the let-down valve outlet and the inlet to the regulator, is desirable. Size the gage for the maximum pressure it could sense, usually taken as that at the inlet of the let-down valve.

### OPERATION

During pump tests and/or let-down valve tests, observe the pressure in the pipe line ahead of the regulator under a variety of conditions. Check that the pressure specifications are met under flow conditions. Contact Yarway immediately if there are any questions regarding performance.

Following the operational checks above, make periodic performance checks when convenient by noting the inlet pressure and comparing it with previous observations.

### MAINTENANCE

There are no routine maintenance procedures for the Back Pressure Regulator.

### DISASSEMBLY / SERVICE / REASSEMBLY

Before any service starts, pressure must be relieved and flow to the regulator must be blocked. Pressure or vacuum downstream must be relieved. If connection is made into and below the water level in a tank, the tank must be drained below the regulator connection. If possible, allow time for cooling of elevated temperatures to prevent injury due to possible contact.

#### Disassembly

Loosen the flanged joint holding the regulator. Remove the regulator from the pipe. Place the regulator on wood blocks or other clean, flat wooden surface. Do not mark or scratch the gasket sealing surfaces. To disassemble the regulator:

Carefully drill out the stake mark with a small drill. Remove orifice (3/4" only). Install draw bolt and washer (see Table A for sizes) and tighten until "snug" (torque = 5 to 10 ft-lb). Loosen retaining ring (clockwise) approximately one turn and remove spiral ring. The BPR unit can now be removed as an assembly. Use a soft metal rod to drive assembly in same direction as flow arrow.

#### CAUTION

*The Back Pressure Regulator has an internal spring and if the draw bolt is removed, it should be done carefully.*

# YARWAY BACK PRESSURE REGULATOR 3/4" THRU 6"

## INSTALLATION AND MAINTENANCE INSTRUCTIONS

3/4" SIZE

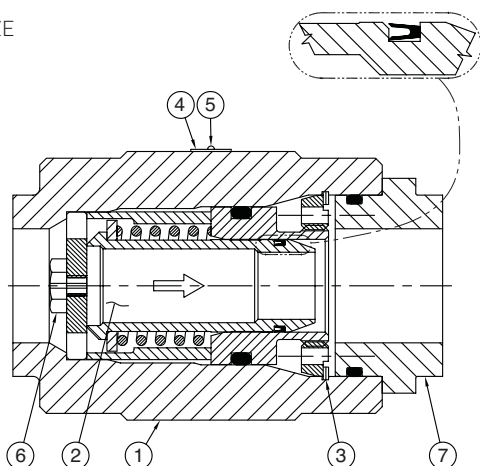

1 1/2" - 6" SIZE

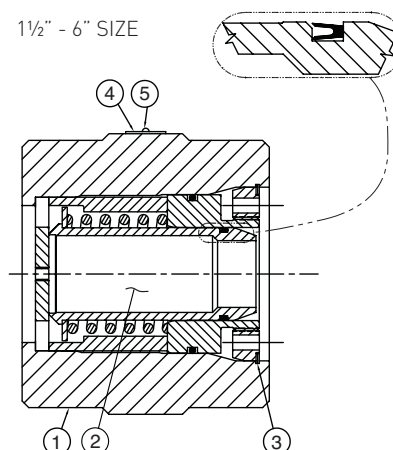

TABLE A

BPR size	Bolt thread	Bolt length	Min. thread length	Washer O.D.	Washer I.D.	Washer thickness
3/4" - 1 1/2"	10-24	3 1/2"	1 1/2"	1 1/16"	7/32"	1/16"
2"	1/4-20	4"	1 1/2"	1 3/8"	7/32"	1/16"
3"	1/4-20	5 1/2"	1 3/4"	2 1/16"	7/32"	1/8"
4"	5/16-18	7"	2 1/4"	2 7/8"	11/32"	1/8"
6"	3/8-16	7 1/2"	3"	4 1/2"	13/32"	1/8"

PARTS LIST

Item	Part
1	Body
2	Capsule assembly
3	Spiral ring
4	Nameplate
5	Drive screw
6	Orifice
7	Raised face adapter

### Service

The internal parts are replaced as a calibrated capsule assembly and are not available as individual parts.

### Reassembly

Place regulator flange face down.

- Lubricate O-ring with O-ring lubricant and install BPR capsule into body. Use the following lubricants or their equivalents:
  - Anti-seize: Never-Seez NS 165 (pure nickel special).
  - O-ring: P-80 rubber lubricant or liquid soap (International Products Corp.).

- Install spiral ring into body groove (lubricate bottom side with anti-seize).
- Prep exposed plunger guide threads with Loctite Grade T Primer; coat with Loctite 272 (thread locking adhesive). Back retaining ring out to load BPR capsule with required torque. Remove and discard draw bolt and washer (used to hold the capsule assembly together). Stake plunger guide into retaining ring; do not stake toward centerline of BPR. Install orifice (torque = 15-20 in-lb). Recommend new orifice when installing new assembly. Orifice is used on 3/4" size only.

Regulator size	Nut size	Torques	
		ft-lb	(Nm)
3/4" - 1 1/2"	1 1/8-12	20-25	(27-34)
2	1 7/16-12	45-55	(61-75)
3	2 1/8-12	100-120	(136-163)
4	2 7/8-12	180-220	(244-298)
6	4 3/4-12	300-340	(406-460)

The unit is reassembled and ready for installation. Keep it clean and free of foreign matter and objects.

# YARWAY BACK PRESSURE REGULATOR 3/4" THRU 6"

## INSTALLATION AND MAINTENANCE INSTRUCTIONS

---

### TROUBLESHOOTING AND DIAGNOSIS

Symptom	Probable cause	Corrective action
Sudden pressure loss	Object holding piston open	Increase flow rate and flush object through Disassemble and remove object. See 'Disassembly / Service / Reassembly'
Long term pressure loss	Orifice enlargement Piston leading edge worn	Recondition Recondition