



ANDERSON GREENWOOD MARVAC FIGURE 121F PRESSURE AND VACUUM RELIEF VALVES INSTALLATION AND MAINTENANCE INSTRUCTIONS

Read Anderson Greenwood Marvac general instructions before continuing

SAFETY PRECAUTIONS

Read and understand this instruction manual before installing, operating or performing maintenance on a 121F pressure and vacuum relief valve. Follow all precautions and warnings noted herein when installing, operating or performing maintenance on this equipment.

Safety precaution definitions

CAUTION

Damage to equipment may result if this precaution is disregarded.

WARNING

Direct injury to personnel or damage to equipment that can cause injury to personnel may result if this precaution is not followed.

NOTE

This manual is issued for guidance only and does not affect our standard terms and conditions and our product limited warranty, all of which are available upon request.

1 INSTALLATION

121F pressure and vacuum relief valves must be mated with the appropriate flange.

1. These valves must be gasketed and bolted to a flat machined horizontal flange. Bolts must be tightened uniformly to ensure a good seal.
2. The exhaust pipework which is to be gasketed and bolted to the horizontal flange must not be supported by the valve, i.e. these valves are not designed to carry any external loads.
3. This valve does not contain any internal packing. Therefore, internal checks should not be necessary.
4. It is recommended that carbon steel valves be given a coat of paint immediately after installation is complete. Apply paint to external surfaces only.

2 MAINTENANCE (DURING ATMOSPHERIC VENTING PERIOD)

WARNING

The relief valve must be isolated from tank pressure before servicing. All gas must be blocked and pressure safely vented. Wear appropriate gloves and/or breathing apparatus if hazardous vapors are present.

Refer to Figure 1

1. Remove pressure and vacuum covers (item 5), inspect O-ring for damage and replace if necessary.
2. Remove pallet assemblies to inspect pallet seating for wear and replace if necessary.
3. To replace damaged/worn items from pallet assembly (see recommended spares):
 - a. Remove nut from pallet stem, remove support disc, diaphragm and backing disc.
 - b. Clean pallet surface and threads.
 - c. Replace with new parts.
 - d. Reassemble in reverse order.
4. Inspect valve seats (item 3) for wear and regrind or replace where necessary.
5. Clean seating surface thoroughly with suitable solvent and apply a thin smear of light spindle oil.
6. Generally clean inside of valve, remove all foreign matter and repaint exterior where possible to prevent corrosion.
7. Replace pressure pallet on pressure seat and vacuum pallet on vacuum seat (with lead disc if fitted).
8. Replace pressure and vacuum covers and replace sealing washers if necessary, secure with screws.

CAUTION

The end of the pallet stem must engage the stem guide in the cover to ensure correct seating and valve operation.

NOTE

The efficiency of the valve depends on maintaining good seating surfaces. Therefore, maintenance periods should be adjusted to suit service conditions.

3 RECOMMENDED SPARES

When spare parts are required the customer should quote the valve size, serial number, the item number and the material of the parts required.

The valve size and serial number can be obtained from the valve identification label. The item number and description can be obtained from the arrangement on page 2. Care should be taken to quote the correct material as the materials quoted are for non hazardous conditions.

ANDERSON GREENWOOD MARVAC FIGURE 121F PRESSURE AND VACUUM RELIEF VALVES

INSTALLATION AND MAINTENANCE INSTRUCTIONS

FIGURE 1

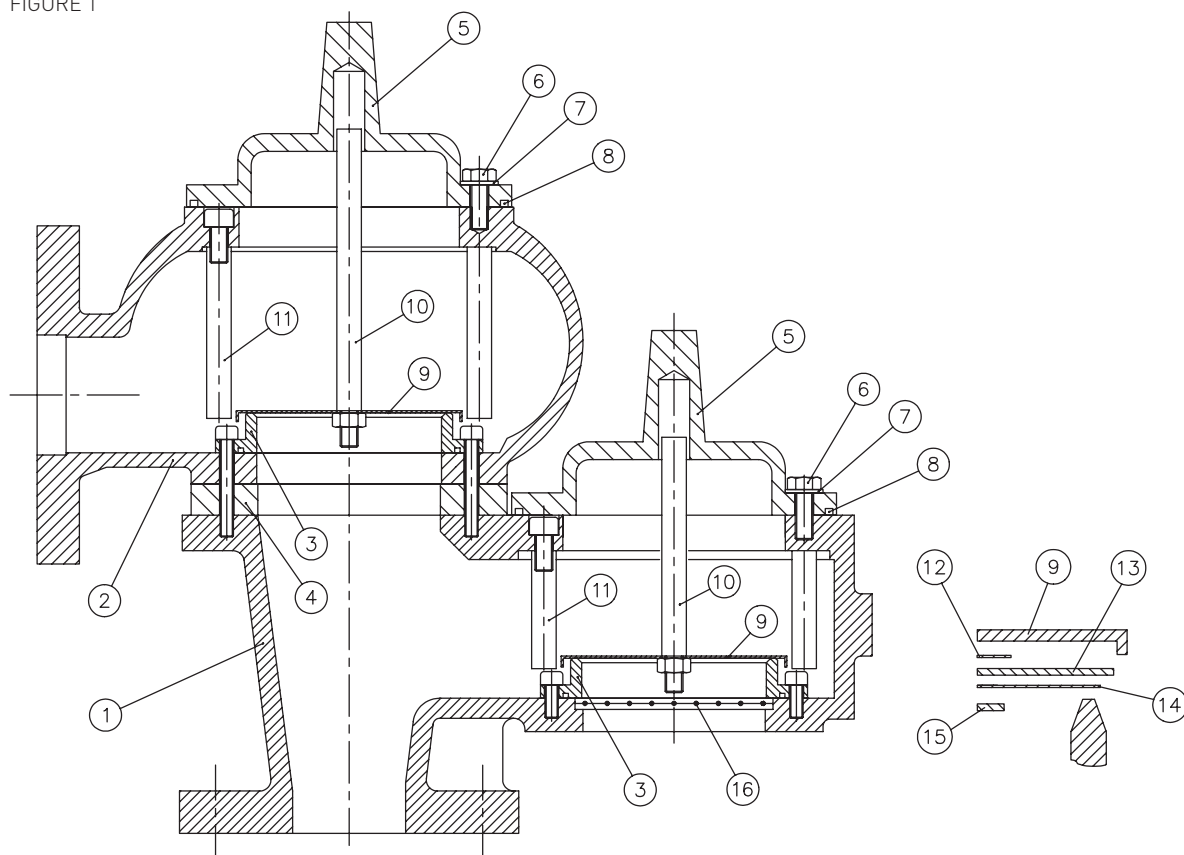

PARTS LIST

Item	Description	Alum spec.	C. steel	SS. spec
1	Valve body inlet	Alum	W.C.B	316 SS
2	Valve body outlet	Alum	W.C.B	316 SS
3	Removable seat	Alum	316 SS	316 SS
4	Spacer ring	Alum	C Steel	316 SS
5	Cover	Alum	W.C.B	316 SS
6	Cover screws	ZP Steel	ZP Steel	18/8 SS
7	Sealing washers	G fiber	G fiber	G fiber
8	O-ring seal	Nitrile	Nitrile	Nitrile
9	Pallet	316 SS	316 SS	316 SS
10	Pallet stem	316 SS	316 SS	316 SS
11	Pallet guide posts	316 SS	316 SS	316 SS
12	Spacer disc	Non-asbestos	Non-asbestos	Non-asbestos
13	Diaphragm back. disc	Non-asbestos	Non-asbestos	Non-asbestos
14	Diaphragm	PTFE	PTFE	PTFE
15	Diaphragm supp. disc	316 SS	316 SS	316 SS
16	Screen	Galv steel	Galv steel	18/8 SS

RECOMMENDED SPARE PARTS

Item	Description
7	Sealing washers
8	Nitrile O-ring
12	Spacer disc (non-asbestos fiber)
13	Diaphragm backing disc (non-asbestos fiber)
14	Diaphragm (PTFE)

Neither Emerson, Emerson Automation Solutions, nor any of their affiliated entities assumes responsibility for the selection, use or maintenance of any product. Responsibility for proper selection, use, and maintenance of any product remains solely with the purchaser and end user.

Anderson Greenwood is a mark owned by one of the companies in the Emerson Automation Solutions business unit of Emerson Electric Co. Emerson Automation Solutions, Emerson and the Emerson logo are trademarks and service marks of Emerson Electric Co. All other marks are the property of their respective owners.

The contents of this publication are presented for informational purposes only, and while every effort has been made to ensure their accuracy, they are not to be construed as warranties or guarantees, express or implied, regarding the products or services described herein or their use or applicability. All sales are governed by our terms and conditions, which are available upon request. We reserve the right to modify or improve the designs or specifications of such products at any time without notice.