



## ANDERSON GREENWOOD MARVAC FIGURE 121FS PRESSURE AND VACUUM RELIEF VALVES INSTALLATION AND MAINTENANCE INSTRUCTIONS

Read Anderson Greenwood Marvac general instructions before continuing

---

### SAFETY PRECAUTIONS

*Read and understand this instruction manual before installing, operating or performing maintenance on a 121FS pressure and vacuum relief valve. Follow all precautions and warnings noted herein when installing, operating or performing maintenance on this equipment.*

### NOTE

This manual is issued for guidance only and does not affect our standard terms and conditions and our product limited warranty, all of which are available upon request.

### 1 INSTALLATION

---

121FS pressure and vacuum relief valves must be mated with the appropriate flange.

1. These valves must be gasketed and bolted to a flat machined horizontal flange. Bolts must be tightened uniformly to ensure a good seal.
2. The pressure setting on these valves is controlled by a compression spring, which is adjusted and set at works before dispatch. However, final setting using adjustment screw may be necessary to suit site conditions.
3. The exhaust pipework which is to be gasketed and bolted to the horizontal flange must not be supported by the valve, i.e. these valves are not designed to carry any external loads.
4. This valve does not contain any internal packing. Therefore, internal checks should not be necessary.
5. It is recommended that carbon steel valves be given a coat of paint immediately after installation is complete. Apply paint to external surfaces only.

# ANDERSON GREENWOOD MARVAC FIGURE 121FS PRESSURE AND VACUUM RELIEF VALVES

## INSTALLATION AND MAINTENANCE INSTRUCTIONS

---

### 2 MAINTENANCE (DURING ATMOSPHERIC VENTING PERIOD)

---

#### WARNING

*The relief valve must be isolated from tank pressure before servicing. All gas must be blocked and pressure vented safely.*

*Wear appropriate gloves and/or breathing apparatus if hazardous vapors are present.*

#### Pressure relief (refer to Figure 1)

1. Remove bonnet cap (item 6) and note exact position (height) of the adjustment screw (item 7).
2. Remove locknut (item 8) and unscrew adjustment screw.
3. Remove spring bonnet (item 5) and spring assembly, inspect O-rings for damage and replace if necessary.
4. Remove pallet assembly to inspect pallet seating for wear and replace if necessary.
5. To replace damaged/worn items from pallet assembly (see recommended spares):
  - a. Remove nut from pallet stem, remove support disc, diaphragm and backing disc.
  - b. Clean pallet surface and threads.
  - c. Replace with new parts.
  - d. Reassemble in reverse order.
6. Inspect valve seat (item 3) for wear and regrind or replace where necessary.
7. Clean seating surface thoroughly with suitable solvent and apply a thin smear of light spindle oil.
8. Generally clean the inside of the valve, remove all foreign matter and repaint exterior where possible to prevent corrosion.
9. Replace in reverse order ensuring the pallet stem (item 17) sits in the pivot in the pallet assembly.
10. Reset adjustment screw to its original position (height), tighten locknut and replace cap.
11. Check pressure relief setting on test run and adjust if necessary.

#### Vacuum relief (refer to Figure 1)

1. Remove vacuum cover (item 15) inspect O-ring for damage and replace if necessary.
2. Remove pallet assembly to inspect pallet seating for wear and replace if necessary. To replace damaged/worn items from pallet assembly (see recommended spares):
  - e. Remove nut from pallet stem, remove support disc, diaphragm and backing disc.
  - f. Clean pallet surface and threads.
  - g. Replace with new parts.
  - h. Reassemble in reverse order.
4. Inspect valve seat (item 3) for wear and regrind or replace where necessary.
5. Clean seating surface thoroughly with suitable solvent and apply a thin smear of light spindle oil.
6. Generally clean the inside of the valve, remove all foreign matter and repaint exterior where possible to prevent corrosion.
7. Replace vacuum pallet (with lead disc if fitted).
8. Replace vacuum cover and replace (renew) sealing washers if necessary, secure with screws.

#### CAUTION

*The end of the pallet stem must engage the stem guide in the cover to ensure correct seating and valve operation.*

#### NOTE

The efficiency of the valve depends on maintaining good seating surfaces. Therefore, maintenance periods should be adjusted to suit service conditions.

### 3 RECOMMENDED SPARES

---

Item	Description
13	Sealing washers
14	Nitrile O-ring
19	Spacer disc (non-asbestos fiber)
20	Diaphragm backing disc (non-asbestos fiber) Not required for settings over 200 mbar
21	Diaphragm (PTFE)

# ANDERSON GREENWOOD MARVAC FIGURE 121FS PRESSURE AND VACUUM RELIEF VALVES

## INSTALLATION AND MAINTENANCE INSTRUCTIONS

FIGURE 1

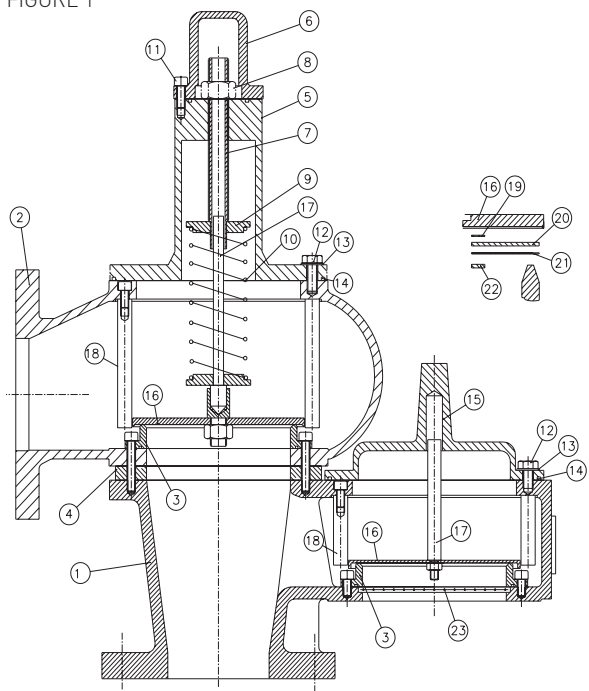

### PARTS LIST

Item	Description	Alum spec.	C. steel	SS. spec
1	Valve body inlet	Alum	W.C.B	316 SS
2	Valve body outlet	Alum	W.C.B	316 SS
3	Removable seat	Alum	316 SS	316 SS
4	Spacer ring	Alum	C.Steel	316 SS
5	Spring bonnet	Alum	W.C.B	316 SS
6	Bonnet cap	Alum	W.C.B	316 SS
7	Adjustment screw	316 SS	316 SS	316 SS
8	Locknut	18/8 SS	18/8 SS	18/8 SS
9	Spring washers	316 SS	316 SS	316 SS
10	Spring	316 SS	316 SS	316 SS
11	Cap screw	ZP Steel	ZP Steel	18/8 SS
12	Bonnet screws	ZP Steel	ZP Steel	18/8 SS
13	Sealing washers	G fiber	G fiber	G fiber
14	O-ring seal	Nitrile	Nitrile	Nitrile
15	Cover	Alum	W.C.B	316 SS
16	Pallet	316 SS	316 SS	316 SS
17	Pallet stem	316 SS	316 SS	316 SS
18	Pallet guide posts	316 SS	316 SS	316 SS
19	Spacer disc	Non-asbestos	Non-asbestos	Non-asbestos
20	Diaphragm back. disc	Non-asbestos	Non-asbestos	Non-asbestos
21	Diaphragm	PTFE	PTFE	PTFE
22	Diaphragm supp. disc	316 SS	316 SS	316 SS
23	Screen	Galv St	Galv St	18/8 SS

Neither Emerson, Emerson Automation Solutions, nor any of their affiliated entities assumes responsibility for the selection, use or maintenance of any product. Responsibility for proper selection, use, and maintenance of any product remains solely with the purchaser and end user.

Anderson Greenwood is a mark owned by one of the companies in the Emerson Automation Solutions business unit of Emerson Electric Co. Emerson Automation Solutions, Emerson and the Emerson logo are trademarks and service marks of Emerson Electric Co. All other marks are the property of their respective owners.

The contents of this publication are presented for informational purposes only, and while every effort has been made to ensure their accuracy, they are not to be construed as warranties or guarantees, express or implied, regarding the products or services described herein or their use or applicability. All sales are governed by our terms and conditions, which are available upon request. We reserve the right to modify or improve the designs or specifications of such products at any time without notice.