



ANDERSON GREENWOOD MARVAC FIGURE 786 EMERGENCY RELIEF MANHOLE COVER INSTALLATION AND MAINTENANCE INSTRUCTIONS

Before installation these instructions must be read fully and understood

SAFETY PRECAUTIONS

Read and understand this instruction manual before installing, operating or performing maintenance on a Figure 786 emergency relief manhole. Follow all precautions and warnings noted herein when installing, operating or performing maintenance on this equipment.

Safety precaution definitions

CAUTION

Damage to equipment may result if this precaution is disregarded.

WARNING

Direct injury to personnel or damage to equipment that can cause injury to personnel may result if this precaution is not followed.

NOTE

This manual is issued for guidance only and does not affect our standard terms and conditions and our product limited warranty, all of which are available upon request.

1 INSTALLATION

786 Emergency relief manholes must be mated with the appropriate flange.

1. These valves must be gasketed and bolted to a flat machined horizontal flange, bolts must be tightened uniformly to ensure a good seal.
2. Ensure that all packing materials are removed from under the cover (Figure 1, item 2) and that the hinged cover is free to move.
3. The vacuum setting is controlled by a compression spring, which is adjusted and tested at the works before dispatch.

CAUTION

Excessive tightening of the flange bolts could affect the sealing of the cover diaphragm.

2 MAINTENANCE

(during atmospheric venting period)

WARNING

The relief manhole must be isolated from tank pressure before servicing. All gas must be blocked and pressure vented safely. Wear appropriate gloves and/or breathing apparatus if hazardous vapors are present.

Pressure relief

1. Lift cover and inspect diaphragm for wear or damage.
2. To replace damaged/worn items from pallet assembly (see recommended spares):
 - a. unbolt drip ring, remove diaphragm & backing disc
 - b. clean pallet surface and threads
 - c. replace with new parts
 - d. reassemble in reverse order
3. Inspect manhole seat for wear and relap if necessary.
4. Lubricate hinge pins.
5. Clean seating surface thoroughly with suitable solvent and apply a thin smear of light spindle oil.
6. Generally clean the inside of the valve, remove all foreign matter and repaint exterior where possible to prevent corrosion.
7. Replace cover on seat carefully.

ANDERSON GREENWOOD MARVAC FIGURE 786 EMERGENCY RELIEF MANHOLE COVER

INSTALLATION AND MAINTENANCE INSTRUCTIONS

Vacuum relief

1. Remove weatherhood and note exact position (height) of the adjustment screw.
2. Open manhole cover and release the locknut. As the adjustment nut is released the vacuum pallet assembly will be released.
3. Remove spring assembly.
4. Inspect pallet seating for wear and replace if necessary.
5. To replace damaged/worn items from pallet assembly (see recommended spares):
 - a. remove nut from pallet stem, remove diaphragm & backing disc
 - b. clean pallet surface and threads
 - c. replace with new parts
 - d. reassemble in reverse order.
6. Replace pallet and spring assembly.
7. Reset adjustment screw to its original position (height) and tighten locknut.
8. Replace weatherhood and secure with handnuts.
9. Check vacuum relief setting and adjust if necessary.

FIGURE 1 - TYPICAL ASSEMBLY

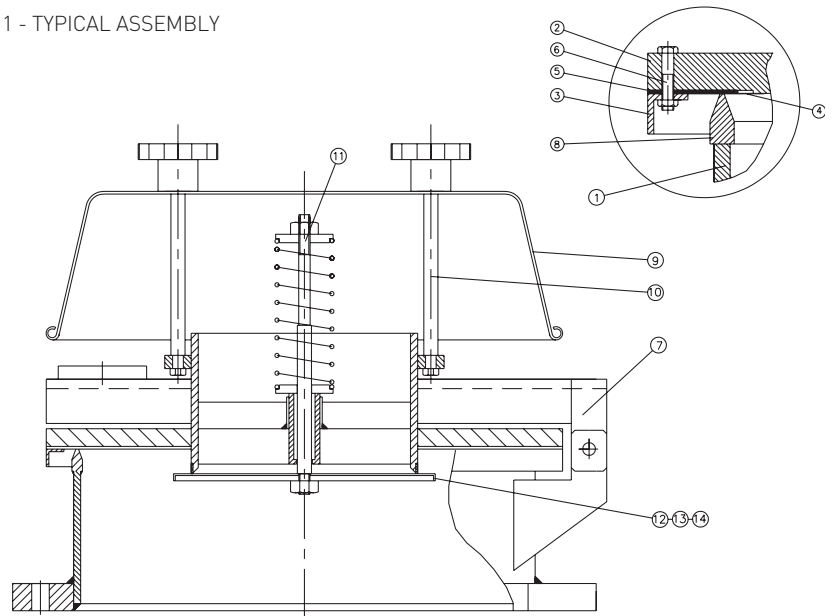

NOTE

The efficiency of the valve depends on maintaining good seating surfaces. Therefore, maintenance periods should be adjusted to suit service conditions.

3 SPARES

When spare parts are required, the customer should quote the valve size, serial number, the item number and the material of the parts required. The valve size and serial number can be obtained from the valve identification label. The item number and description can be obtained from the arrangement (right).

PARTS LIST

Item	Description	CS spec.	SS spec	Alum. spec.
1	Base	C Steel	316 SS	Aluminum
2	Cover plate	C Steel	316 SS	Aluminum
3	Drip ring	C Steel	316 SS	Aluminum
4	Diaphragm	PTFE	PTFE	PTFE
5	Backing disc	Non-asbestos	Non-asbestos	Non-asbestos
6	Clamping screws	Galv Steel	18/8 SS	18/8 SS
7	Hinge arm	C Steel	316 SS	Aluminum
8	Seat ring	316 SS	316 SS	Aluminum
9	Weatherhood	C Steel	316 SS	Aluminum
10	Weatherhood posts	316 SS	316 SS	316 SS
11	Spring assembly	316 SS	316 SS	316 SS
12	Vac pallet	316 SS	316 SS	316 SS
13	Vac diaphragm	PTFE	PTFE	PTFE
14	Vac backing disc	Non-asbestos	Non-asbestos	Non-asbestos

Recommended spares

Pressure

1. Item 4 Diaphragm (PTFE)
2. Item 5 Diaphragm backing disc (Non asbestos fiber)

Vacuum

3. Item 13 Diaphragm (PTFE)
4. Item 14 Diaphragm backing disc (Non asbestos fiber)

Neither Emerson, Emerson Automation Solutions, nor any of their affiliated entities assumes responsibility for the selection, use or maintenance of any product. Responsibility for proper selection, use, and maintenance of any product remains solely with the purchaser and end user.

Anderson Greenwood is a mark owned by one of the companies in the Emerson Automation Solutions business unit of Emerson Electric Co. Emerson Automation Solutions, Emerson and the Emerson logo are trademarks and service marks of Emerson Electric Co. All other marks are the property of their respective owners.

The contents of this publication are presented for informational purposes only, and while every effort has been made to ensure their accuracy, they are not to be construed as warranties or guarantees, express or implied, regarding the products or services described herein or their use or applicability. All sales are governed by our terms and conditions, which are available upon request. We reserve the right to modify or improve the designs or specifications of such products at any time without notice.