

MOD R10: Replacement Procedure

ActCont with ER 2-Way Gas

05-02-11

Actuator Control with ER 2-Way

Replacement Procedure on a Rotary Vane Actuator with a System using Power Gas

MOD R10: Replacement Procedure

ActCont with ER 2-Way - Gas

05-02-11

The purpose of this procedure is to guide the replacement of an Actuator Control with Electric Remote 2-Way features.

This procedure is to be used in conjunction with the following Maintenance and Service Manuals.

Shafer Poppet Block Control Maintenance and Service Manual	Bulletin PBC-01102001
Shafer Hand Pump Maintenance and Service Manual	Bulletin MHP-01102001
Electric Remote 2-Way Schematic	4944-S

WARNING: 1. Turn power gas off (bleed down the power storage tank if applicable).



2. Drain oil out of the gas hydraulic tanks.

Remove the Old Control Box and Hand Pump

1. Remove the piping to the power port and exhaust port (if existing) of the old control block.
2. Remove the two tube lines (OPEN and CLOSE) running from the control block to the top of the gas hydraulic tanks.
3. Remove the tube line going from the power storage tank to the control block, if applicable.
4. Remove the tube lines going from the top of hand pump to the actuator. (Typically with older models, the hand pump will be mounted on the opposite side of the actuator as the control box.)
5. Remove the hand pump suction lines going from the gas hydraulic tanks to the bottom of the hand pump.

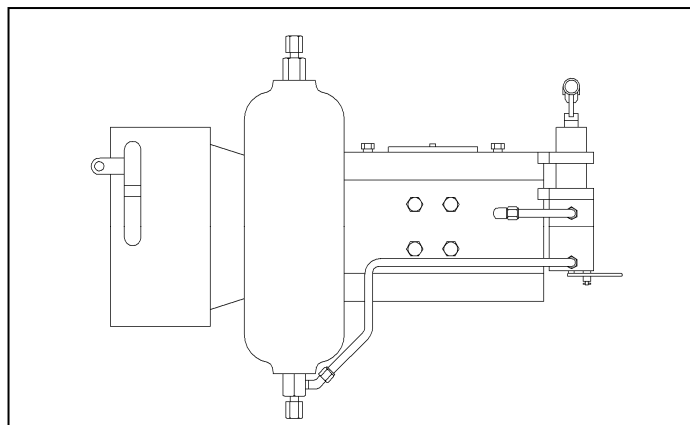

Figure 1: Typical Original Assembly

MOD R10: Replacement Procedure

ActCont with ER 2-Way - Gas

05-02-11

6. This should complete the pipe/tube connections and free the old control box and hand pump for removal. Remove the control box and hand pump. Set the old parts aside for reference.
7. Remove the Diffusers from the top of the gas hydraulic tanks and the drains from the bottom if applicable.

Note: Some gas hydraulic tanks may not have $\frac{3}{4}$ " or larger NPT thread in the bottom and will not accept the new style drain assembly. In this case new drain assemblies will not be included. On these models the suction lines for the hand pump enter the side of the tanks near the bottom and the bottom port remains plugged.

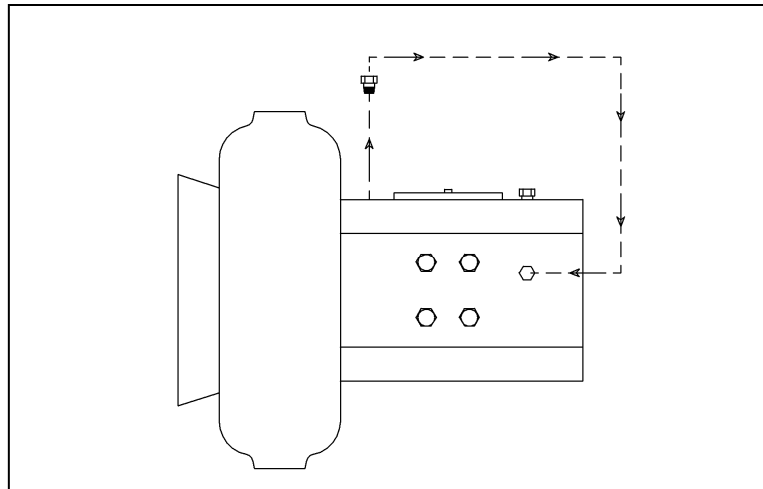

Figure 2: Old Components Removed

8. Remove the fittings in the side of the actuator that were tubed to the OPEN and CLOSE lines from the old hand pump. Also remove the plugs in the upper head on the control side. Clean the threads of the plugs, apply an appropriate pipe sealant and plug the side ports. (See Figure 2)

Install the New Control Box

The new control box mounts to the same holes in the bracket on the gas hydraulic Tanks as the old one using 4" long standoffs. Look the new hardware over to enable identification of the parts.

1. Using 4 of the 8 mounting bolts and lock washers, install the four standoffs to the mounting bracket. Do not tighten the bolts. (See Figure 3)

MOD R10: Replacement Procedure

ActCont with ER 2-Way - Gas

05-02-11

2. With the other four mounting bolts and lock washers install the new control box using the 9.5" x 11.25" hole pattern in the control box back plate. Leave the bolts finger tight.
3. Tighten the mounting bolts in the bracket and then tighten the bolts in the back plate.

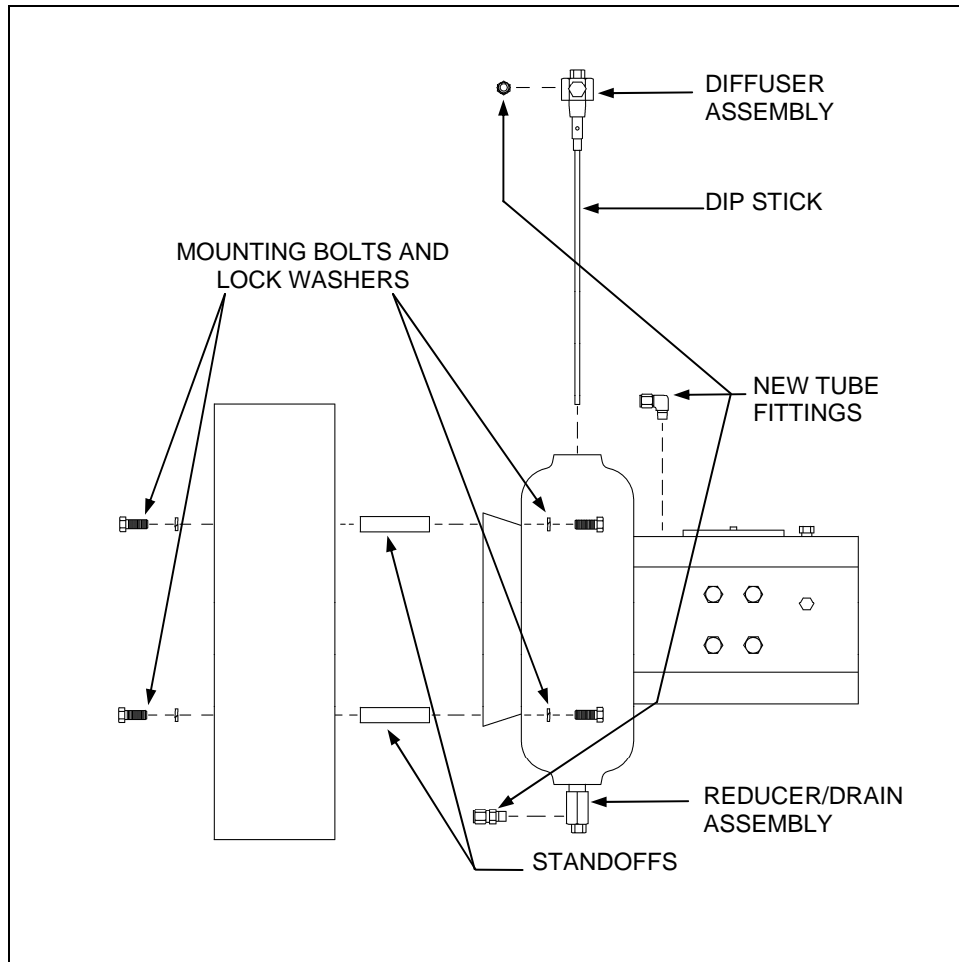

Figure 3: Installing New Control

4. Apply an appropriate pipe sealant and install the new Reducer/Drain Assembly in the bottom of the gas hydraulic tanks if applicable.
5. Assemble the dipsticks to the new Diffuser Assemblies. Apply an appropriate pipe sealant and install the Diffuser Assemblies in the top ports of the gas hydraulic tanks.
6. Remove the existing Lube Extension, if applicable. (See Figure 4)

MOD R10: Replacement Procedure

ActCont with ER 2-Way - Gas

05-02-11

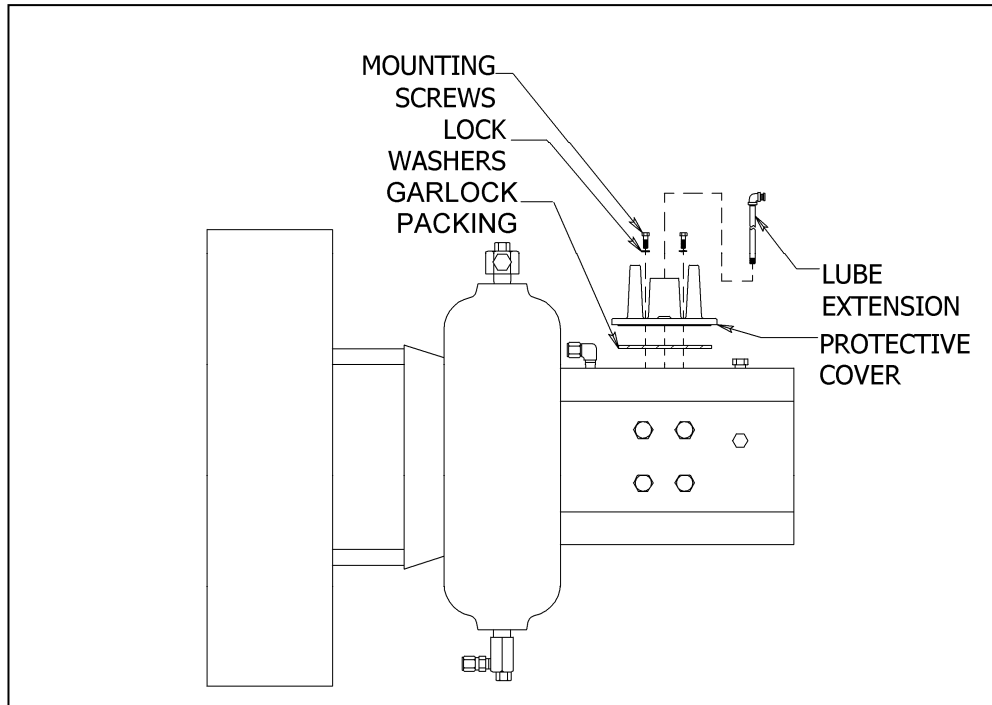

Figure 4: Installing New Protective Cover

7. Remove two hex cap screws holding the Protective Cover and remove.
8. Install the new Garlock Packing into the recess provided in the new Protective Cover (cut Garlock packing to fit).
9. Install the new protective cover using the new Cap Screws and Lock Washers supplied. Ensure the direction arrows are in the correct position.
10. Install new Lube Extension, if applicable.

MOD R10: Replacement Procedure

ActCont with ER 2-Way - Gas

05-02-11

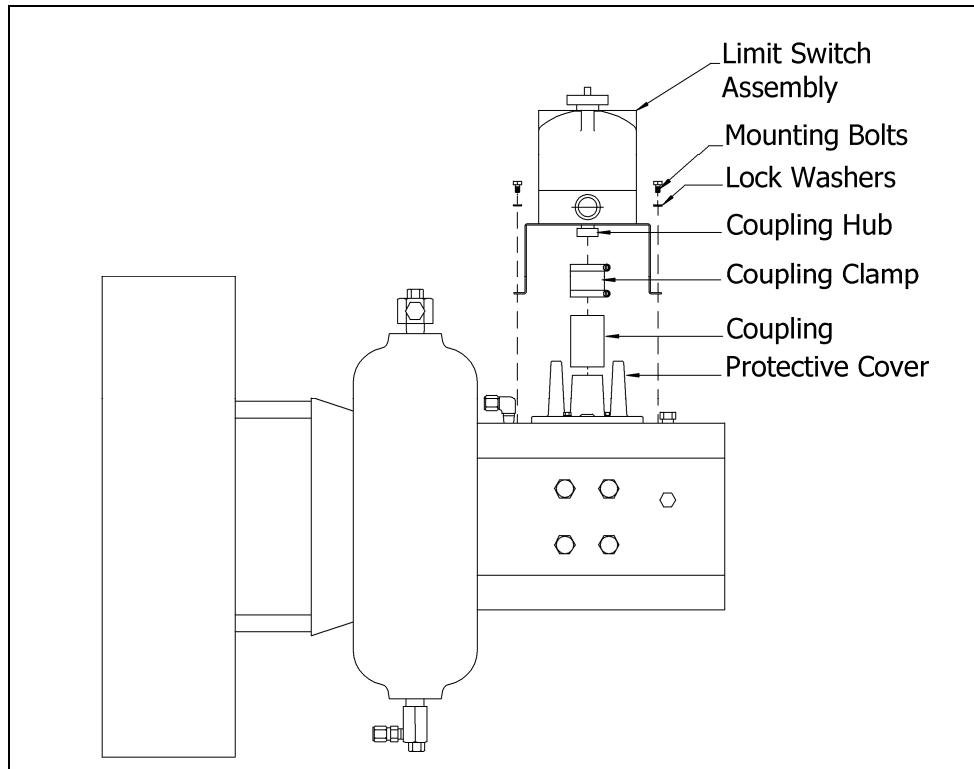

Figure 5: Installing Limit Switch Assembly

11. Slide the Limit Switch Drive Coupling over the center post on the Protective Cover. (see figure 5)
12. Place the Coupling Clamp over the Coupling.
13. Lower the Limit Switch Assembly into position piloting the Coupling hub into the top of the coupling.
14. Align the mounting holes in the Limit Switch Bracket and install the mounting Bolts and Lock Washers. Tighten the bolts.
15. Remove the Limit Switch Assembly's Dome by rotating counter-clockwise.

MOD R10: Replacement Procedure

ActCont with ER 2-Way - Gas

05-02-11

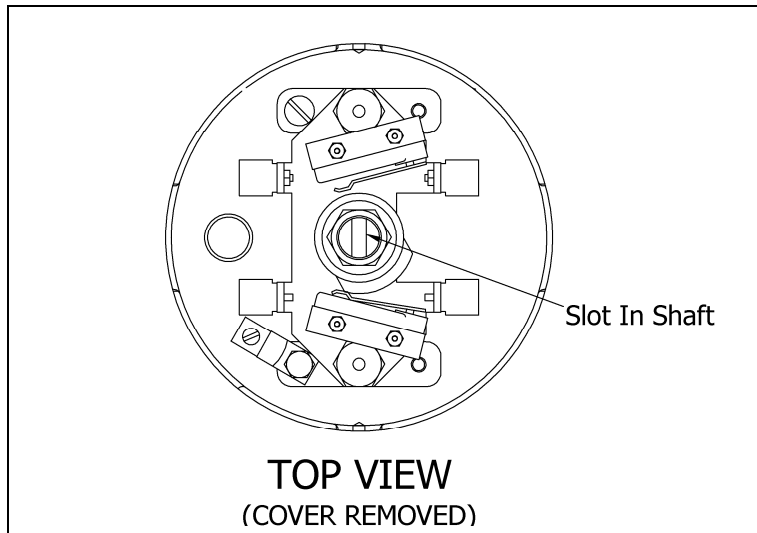

Figure 6: Limit Switch Assembly

16. Looking down at the open Limit Switch assembly note the slot in the top of the shaft. This slot must be aligned inline with, or at 90° of, the pipeline. Once the slot is in line, the Limit Switch Drive Coupling may be tightened.
17. Using the wiring diagram supplied as a reference, make all customer connections required.
18. Install new Swagelok® fittings in the hand pump, actuator upper head, poppet block control solenoid valves and tanks. (See Figures 3 and 7) Apply an appropriate pipe sealant to the threads.
19. Run tubing from the bottom of the gas hydraulic tanks to the suction ports located at the bottom of the hand pump valve body. Right tank (CLOSE) to the right suction port and the left tank (OPEN) to the left suction port (as you are facing the new hand pump).

MOD R10: Replacement Procedure

ActCont with ER 2-Way - Gas

05-02-11

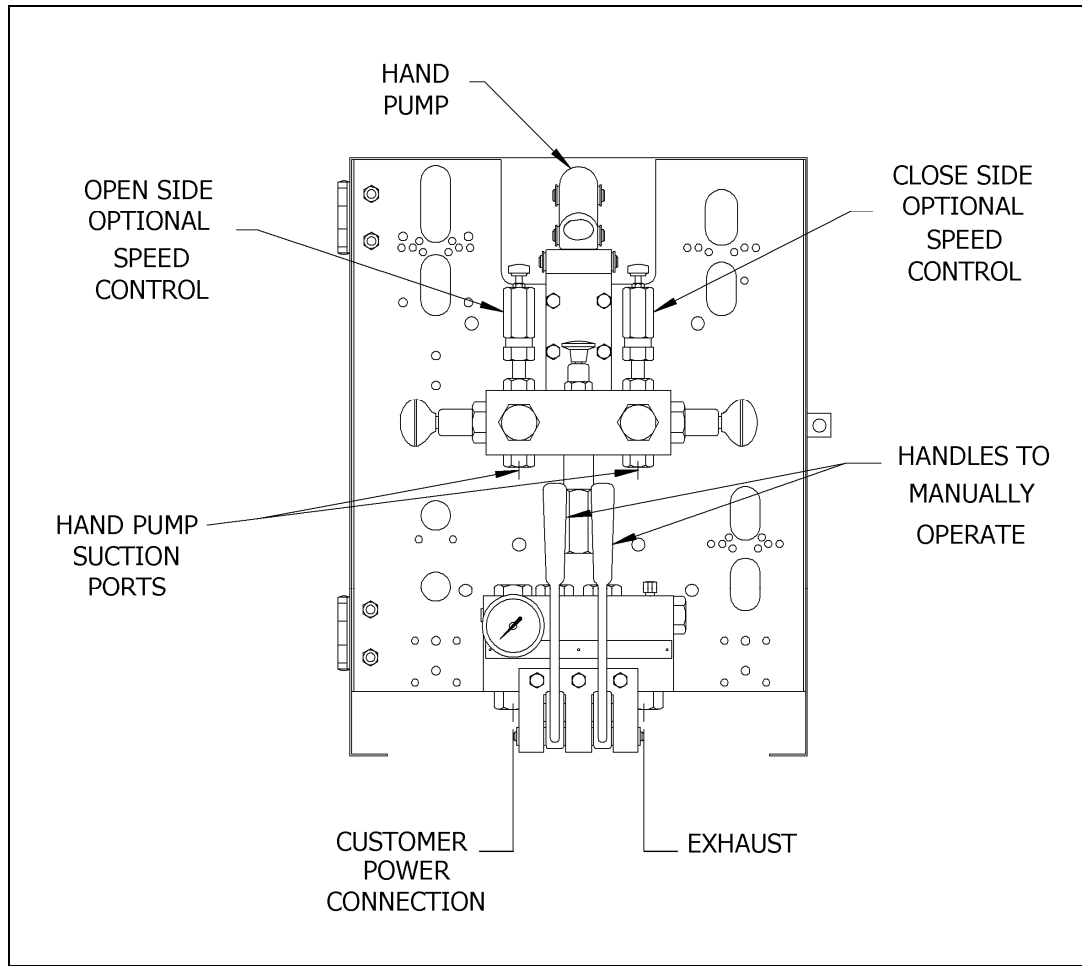

Figure 7: View of the Control from the Front

20. Run tubing from the discharge ports located on top of the hand pump valve body, or optional speed controls if applicable. The right side of the pump runs to the port on the right in the upper head of the actuator (as you are facing the new hand pump). The left side of the pump runs to the port on the left in the upper head of the actuator. (Make sure you are using the ports, in the upper head, closest to control box not the ones on the far side see Figure 3).

MOD R10: Replacement Procedure

ActCont with ER 2-Way - Gas

05-02-11

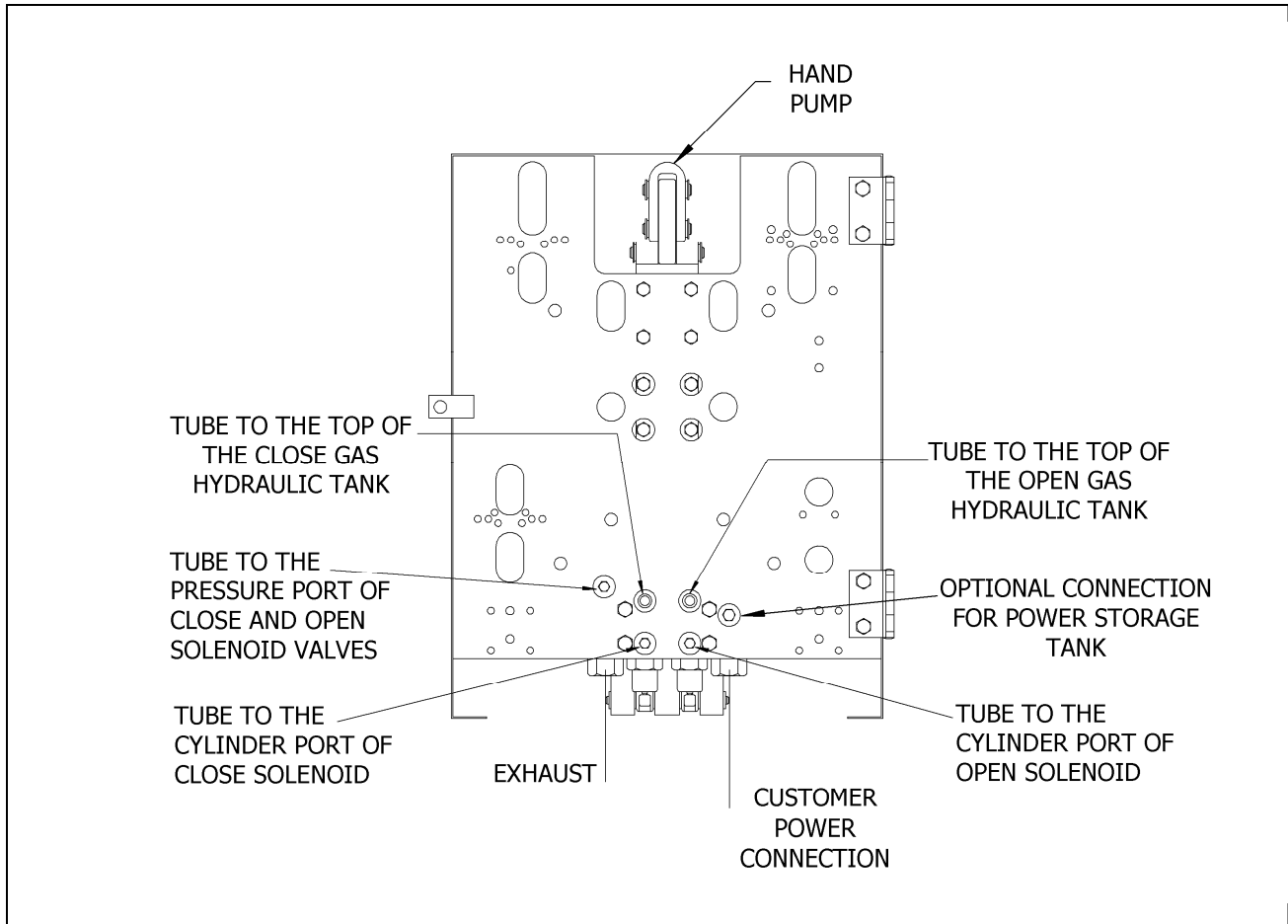

Figure 8: View of the Control from the Back

21. Run tubing from the CLOSE cylinder port of the poppet block control valve to the port in the diffuser assembly on top of the closing gas hydraulic tank. (See Figure 8)
22. Run tubing from the OPEN cylinder port of the poppet block control valve to the port in the diffuser assembly on top of the opening gas hydraulic tank.

NOTE: When facing the **BACK** of the control box the CLOSE cylinder port is on the left and the OPEN is on the right. (See Figure 8)

23. If an optional power storage tank is in use, find the optional connection for the power storage tank to the right of the OPEN cylinder port of the poppet block control valve, when facing the back of the control. (See Figure 8) Run tubing from this port to the port in the top of the power storage tank as originally plumbed.

MOD R10: Replacement Procedure

ActCont with ER 2-Way - Gas

05-02-11

24. Run tubing from the pilot pressure port to the pressure port of both Solenoid Valves. (See Figure 8).
25. Run tubing from the CLOSE PILOT port of the poppet block control valve to the Cylinder port of the CLOSE Solenoid. (See Figure 8 and Figure 9)
26. Run tubing from the OPEN PILOT port of the poppet block control valve to the Cylinder port of the OPEN Solenoid. (See Figure 8 and Figure 9)

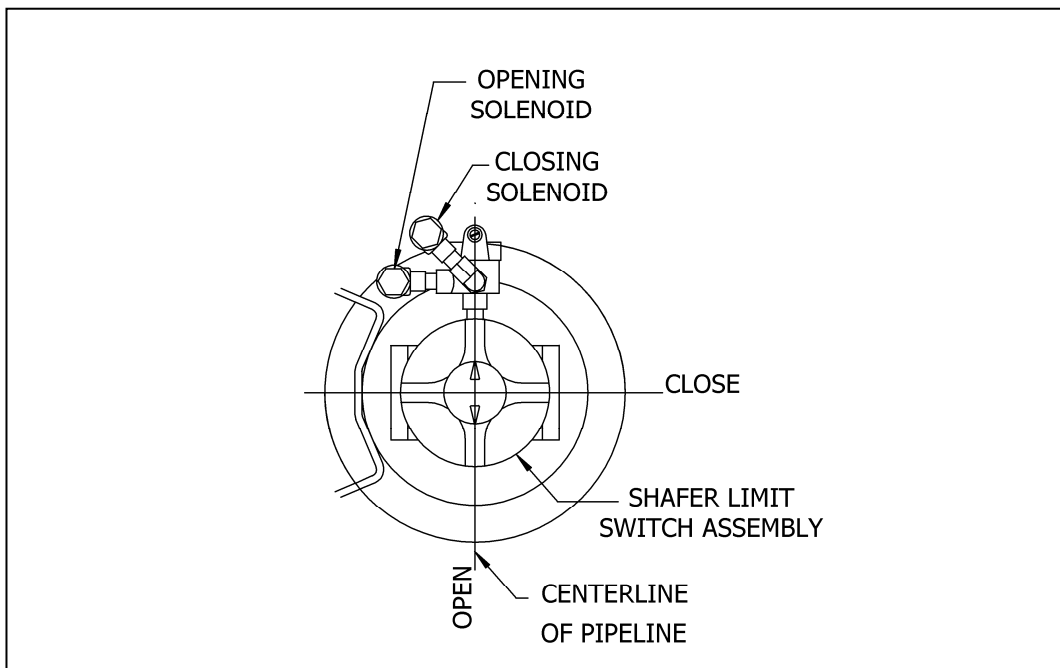

Figure 9: Top View of Limit Switch Assembly and Solenoid Valves

27. Replumb the customer power connection and replumb the exhaust, or install muffler, on the poppet block control valve. (See Figure 8)
28. Fill both of the gas hydraulic tanks to required operating level.
29. Use the hand pump to close or open the actuator to purge the actuator and hydraulic lines. To manually stroke the actuator, either open or closed, select the appropriate knob on the selector valve located on the hand pump. This knob is selected by pressing inward toward the pump center.

Note: The pump has a label designating which knob is open and close.

MOD R10: Replacement Procedure

ActCont with ER 2-Way - Gas

05-02-11

30. Using the supplied pump handle, raise the hand pump clevis, which will draw hydraulic fluid into the pump. Pull the handle downward to discharge hydraulic fluid into the actuator. Repeat this process until the actuator reaches its end of stroke.
31. When the pumping cycle is completed, depress the manual relief valve located top center of the selector valve on the pump and pull the pump ram back into the pump body.
32. The automatic features of the control circuit can now be used.
33. The hand pump will automatically shift to neutral when either the OPEN tank or the CLOSE tank is pressurized during an automatic cycle of the control circuit.
34. Turn power gas on.
35. Stroke the actuator in both directions using power gas pressure and operating the manual handles on the poppet block control valve. Leave the actuator in a safe idle position.
36. Stroke the actuator in both directions using Electric Remote Control, to check operation:
 - a. *Closing the actuator*

With the actuator in the open position, electrically energize the closing 2-way normally closed solenoid valve. Power gas will flow from its power port to its cylinder port and on to pilot the poppet control block to open the Shafer Rotary Vane actuator. The closing 2-way normally closed solenoid valve must be de-energized at the end of the actuator's closing stroke either by limit switch, timer or manually. This will allow the system to be neutralized from pressure.
 - b. *Opening the actuator*

With the actuator in the closed position, electrically energize the opening 2-way normally closed solenoid valve. Power gas will flow from its power port to its cylinder port and on to pilot the poppet control block to close the Shafer Rotary Vane actuator. The opening 2-way normally closed solenoid valve must be de-energized at the end of the actuator's opening stroke either by limit switch, timer or manually. This will allow the system to be neutralized from pressure.
37. Leave the actuator in the desired position.

MOD R10: Replacement Procedure

ActCont with ER 2-Way - Gas

05-02-11

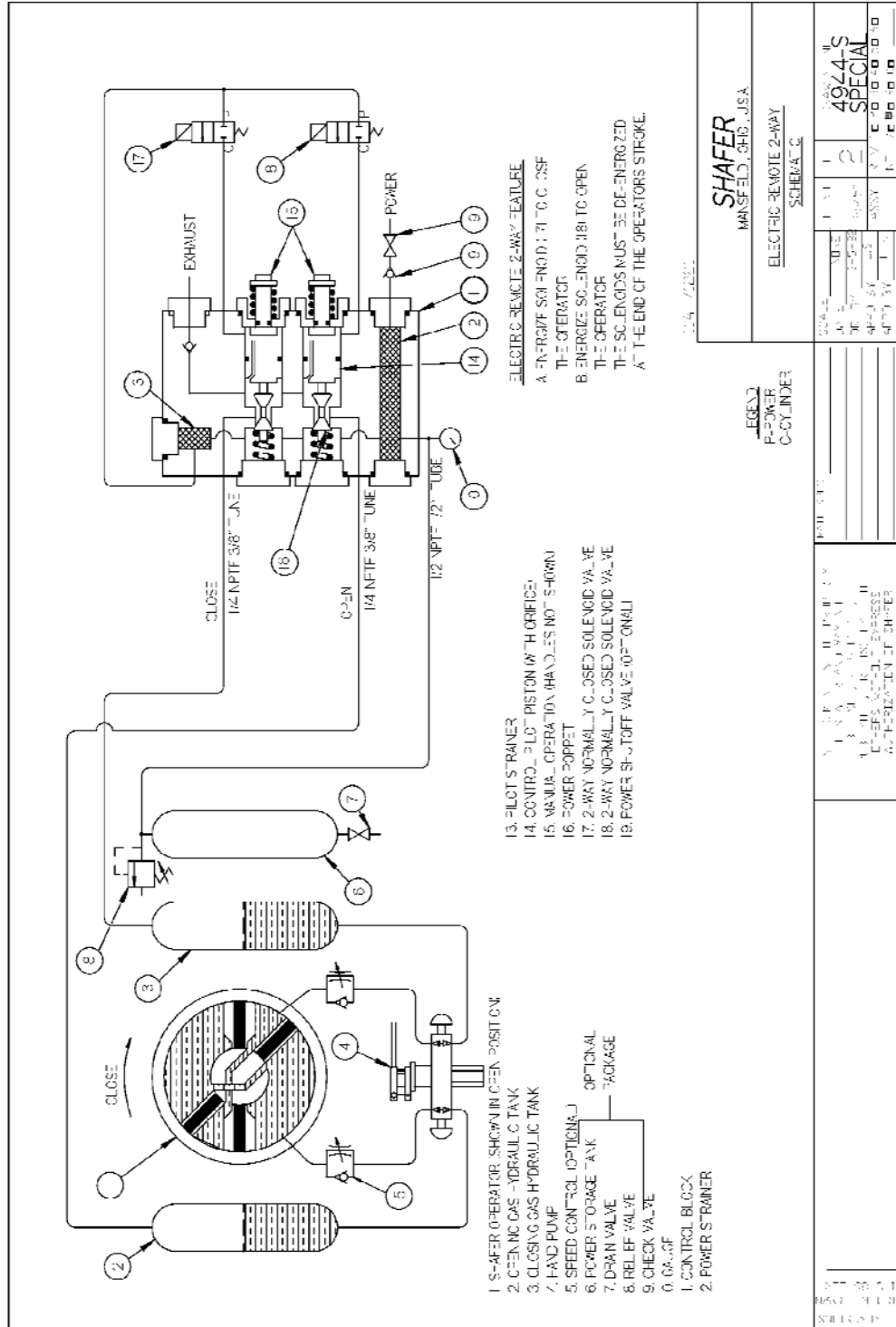

SHAFTER
 MANSFIELD, OHIO, U.S.A.

ELECTRIC REMOTE 2-WAY
 SCHEMATIC 2

REV.	1	1	1
DATE	10/22/88	10/22/88	10/22/88
BY	WSS	WSS	WSS
CHKD	WSS	WSS	WSS
APP'D	WSS	WSS	WSS

4924-S
 SPECIAL

MOD R10: Replacement Procedure

ActCont with ER 2-Way - Gas

05-02-11

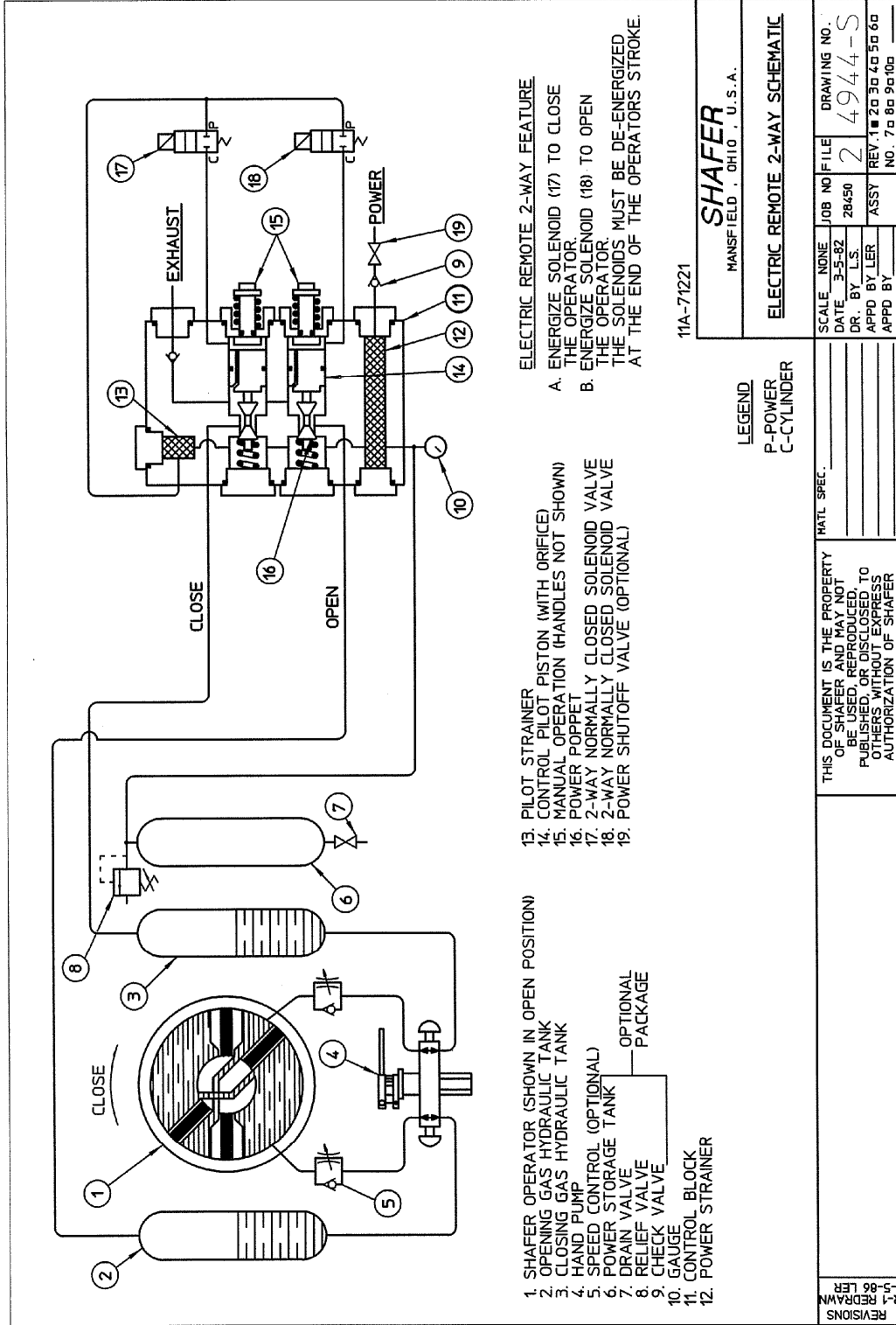

- 1. SHAFER OPERATOR (SHOWN IN OPEN POSITION)
 - 2. OPENING GAS HYDRAULIC TANK
 - 3. CLOSING GAS HYDRAULIC TANK
 - 4. HAND PUMP
 - 5. SPEED CONTROL (OPTIONAL)
 - 6. POWER STORAGE TANK
 - 7. DRAIN VALVE
 - 8. RELIEF VALVE
 - 9. CHECK VALVE
 - 10. GAUGE
 - 11. CONTROL BLOCK
 - 12. POWER STRAINER
 - 13. PILOT STRAINER
 - 14. CONTROL PILOT PISTON (WITH ORIFICE)
 - 15. MANUAL OPERATION (HANDLES NOT SHOWN)
 - 16. POWER POPPET
 - 17. 2-WAY NORMALLY CLOSED SOLENOID VALVE
 - 18. 2-WAY NORMALLY CLOSED SOLENOID VALVE
 - 19. POWER SHUTOFF VALVE (OPTIONAL)
- ELECTRIC REMOTE 2-WAY FEATURE
- A. ENERGIZE SOLENOID (17) TO CLOSE THE OPERATOR.
 - B. ENERGIZE SOLENOID (18) TO OPEN THE OPERATOR.
- THE SOLENOIDS MUST BE DE-ENERGIZED AT THE END OF THE OPERATORS STROKE.

11A-71221

SHAFER
MANSFIELD, OHIO, U.S.A.

ELECTRIC REMOTE 2-WAY SCHEMATIC

SCALE	NONE	JOB NO	FILE	DRAWING NO.
DATE	3-5-82	28450	2	4944-S
DR. BY	L.S.	ASSY		
APPD BY	LER	REV. 1	20 30 40 50 60	
		NO.	7 8 9 10a	

THIS DOCUMENT IS THE PROPERTY OF SHAFER AND MAY NOT BE USED, REPRODUCED, PUBLISHED, OR DISCLOSED TO OTHERS WITHOUT EXPRESS AUTHORIZATION OF SHAFER

MATL SPEC.

LEGEND
P-POWER
C-CYLINDER

MOD 8: Replacement Procedure

ActCont with ER 2-Way - Gas

05-02-11

If any further information is required, please feel free to contact:

Emerson Process Management
Valve Automation Inc.
2500 Park Avenue West
Mansfield, Ohio 44906

Phone: (419) 529-4311

Fax (419) 529-3688

Please visit our website for up to date product data. www.shafervalve.com

All Rights Reserved

The contents of this publication are presented for informational purpose only, and while every effort has been made to ensure their accuracy, they are not to be construed as warranties or guarantees, express or implied, regarding the products or services described herein or their use or applicability. We reserve the right to modify or improve the designs or specifications of such products at any time with out notice.

Trademarks owned by other companies that are referred to in our product literature include: Swagelok®