

**RAP R10: Air Relay Valve Service and Adjustment**  
ARV-69626/69627  
05/05/11

# Air Relay Valve Service and Adjustment

**A. Disassemble and Clean**

Information enclosed in brackets (item 1 etc.) is in reference to the complete assembly drawings on page 6 and the illustrations throughout the document.

1. Remove spring retainer (item 3), adjusting cap (item 4) and locknut (item 5), as a unit, from the body (item 1) and set aside.
2. Remove cylinder cap (item 6) and o-ring (item 12).
3. Remove Gits cup (item 19).
4. Remove cylinder (item 2).
5. Hold cylinder (item 2), and with a blunt rod, push piston (item 7) out of the cylinder. Remove o-ring (item 13).
6. Clean cylinder, piston and cylinder cap.
7. Lubricate and install new o-ring (item 13) on piston (item 7) and new o-ring (item 12) on cylinder cap (item 6). Set cylinder, piston and cylinder cap aside.
8. Slowly pull valve stem (item 10) out of body (item 1) and set aside on a clean surface.
9. Carefully remove end valve sleeves (item 9) and center valve sleeve (item 8). **Note how they go together.**
10. Clean stem (item 10) with a soft cloth, Do Not scratch the stem. Clean the end sleeves (item 9) and center sleeve (item 8).
11. Lubricate and install new outer o-ring (item 14) and install new inner o-ring (item 15), without lube, on one end sleeve (item 9). From the spring retainer end, fit the end sleeve into the bore of the body with the o-rings toward the spring retainer threads. Insert the sleeve until the outer o-ring is about to enter the bore. (See Figure 1)

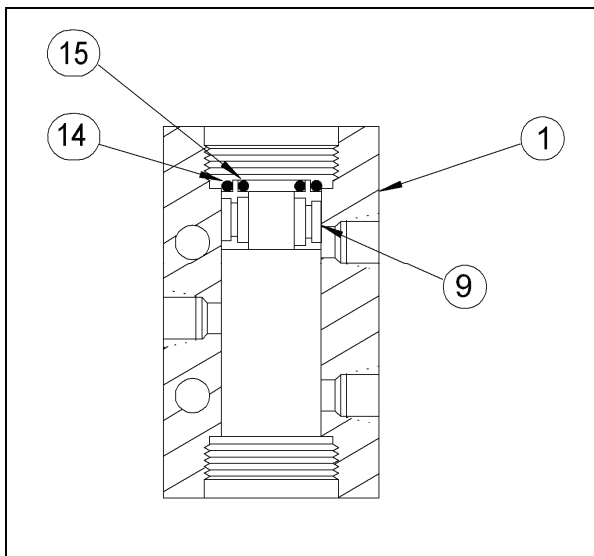

**Figure 1**

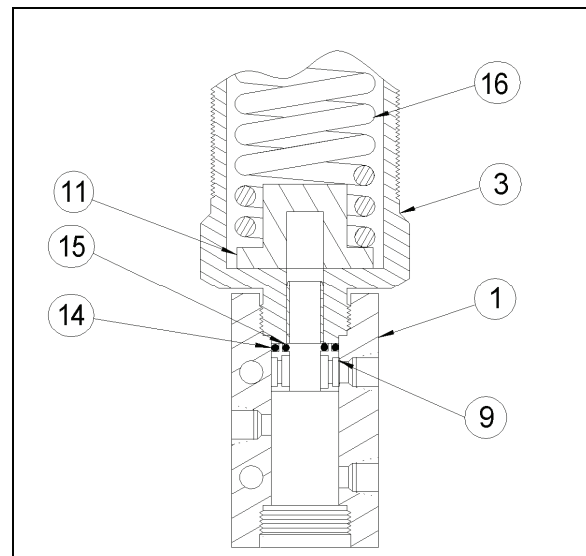

**Figure 2**

12. Install the spring retainer (item 3), adjusting cap (item 4) and locknut (item 5), as a unit. As you thread the spring retainer in, it will push the o-ring and sleeve into the bore to the correct position. Tighten spring retainer hand tight. (See Figure 2)

# RAP R10: Air Relay Valve Service and Adjustment

ARV-69626/69627

05/05/11

## Air Relay Valve

13. Turn the valve body (item 1) so that the open end of the bore is up. Install new inner o-rings (item 15), without lube, in the center sleeve (item 8). Place new lubricated o-ring (item 14) in the bore of the body (item 1) on top of the end sleeve (item 9). (See Figure 3)
14. Carefully slide the center sleeve (item 8) into the bore in of the body. When it reaches the outer o-ring (item 14) laying on the end sleeve (item 9) press the center sleeve to seat the o-ring. (See Figure 4)

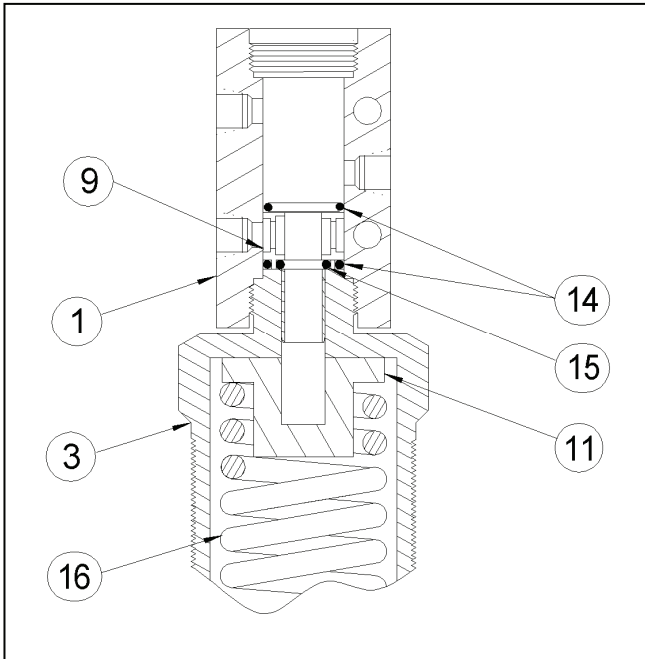

Figure 3

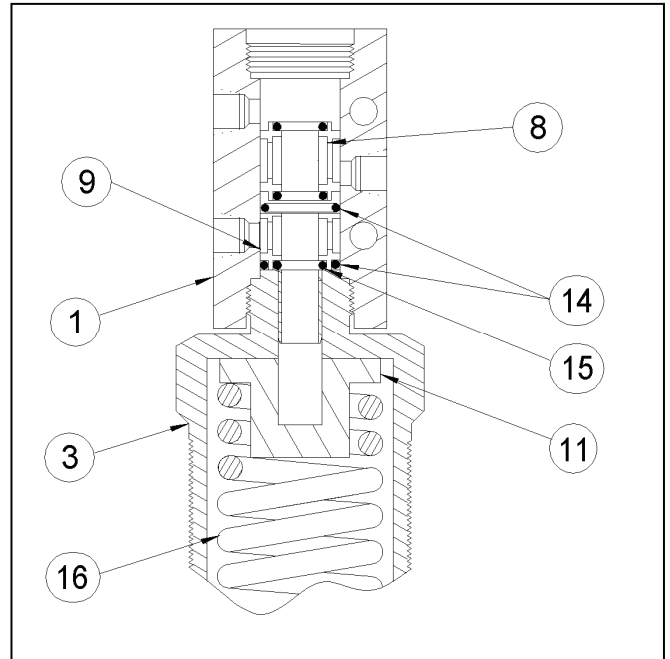

Figure 4

15. Place a lubricated outer o-ring (item 14) in the bore of the body (item 1) on top of the center sleeve (item 8). Do not try to seat o-ring at this time. (See Figure 5)

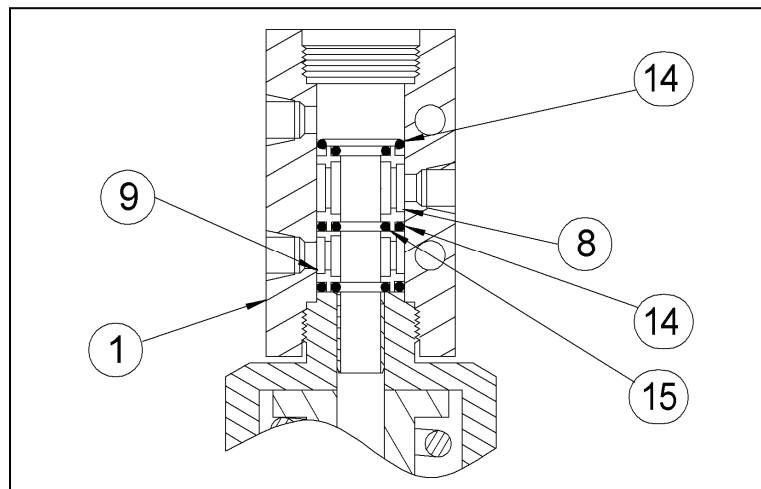
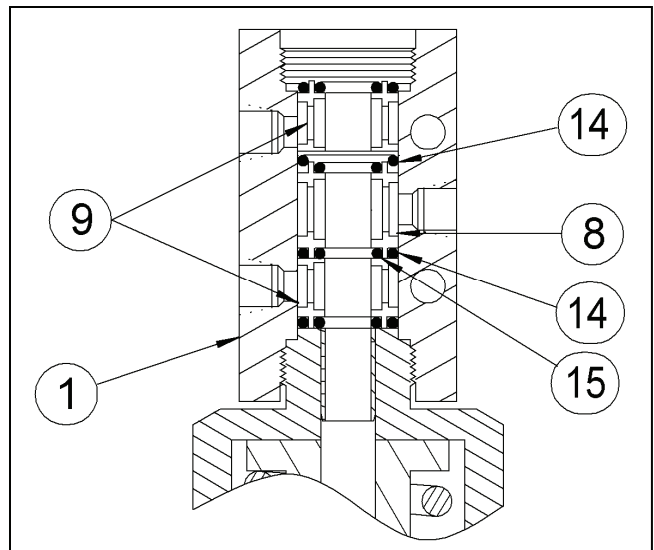

Figure 5

16. Install new inner o-rings (item 15), without lube, and lubricated outer ring (14) in the second end sleeve (item 9). Slide the end sleeve into the bore of the body (item 1) with the o-ring grooves out toward the cylinder threads. Insert the sleeve until the outer o-ring is about to enter the bore. (See Figure 6)



**Figure 6**

17. Install the cylinder (item 2). As you thread the cylinder in, it will push the o-ring and sleeve into the bore to the correct position. This action will also seat the o-ring in the center sleeve. Tighten cylinder (item 2) to the body (item 1) hand tight.

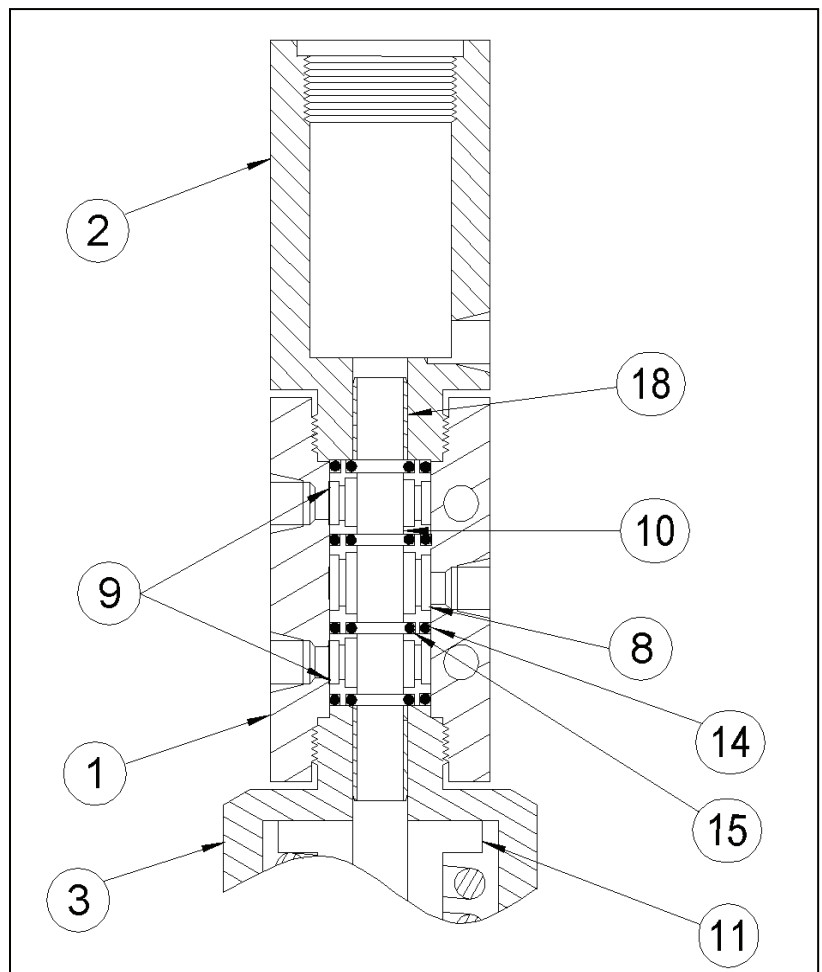

**Figure 7**

18. Lubricate the tip of the stem (item 10), note taper, and carefully insert, pushing toward the spring end. (See Figure 8)

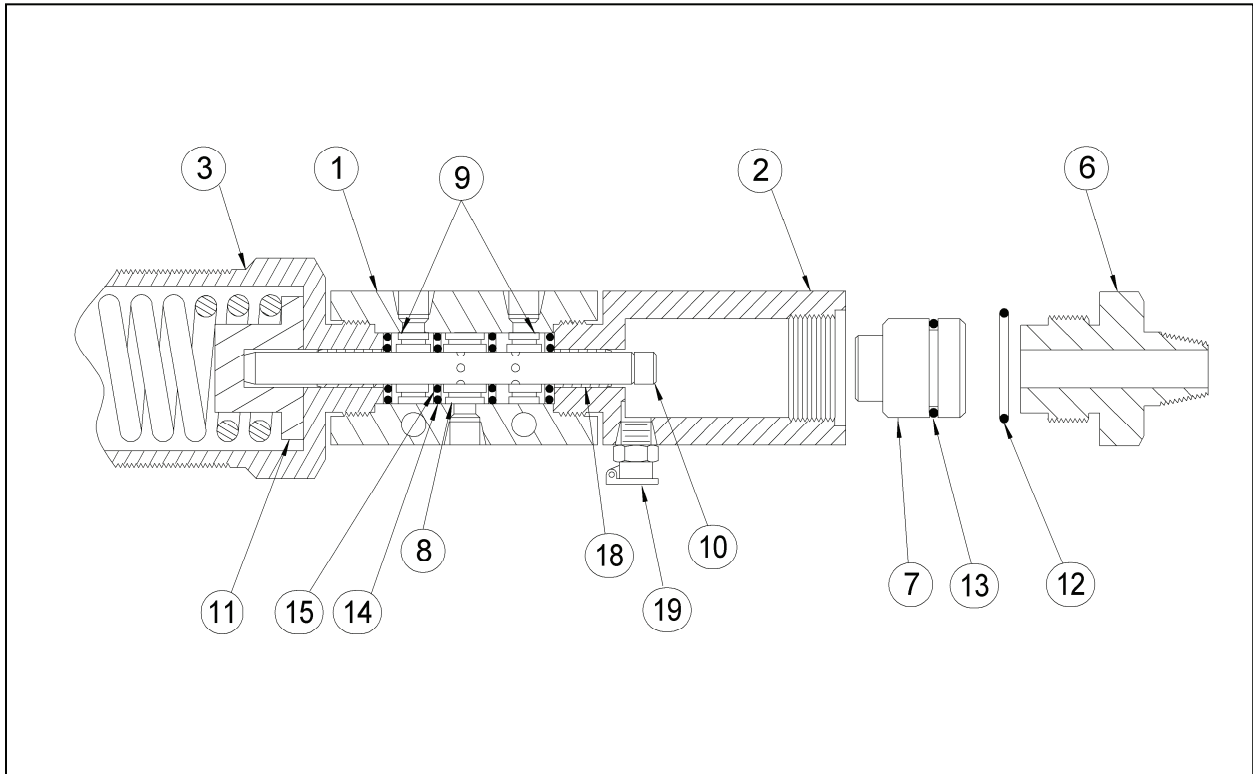

**Figure 8**

19. Insert piston (item 7) into cylinder (item 2) and thread the cylinder cap (item 6) in hand tight. (See Figure 8)

20. Replace Gits cup (item 19). (See Figure 8)

21. Hold the assembly by gripping the spring retainer (item 3) on its flats and tighten the complete assembly with the hex cylinder cap (item 6). Torque to 120 inch pounds.

## **B. Valve Setting Procedure**

1. Mount the air relay valve in a stand that has a 1400-psi maximum supply with an adjustable regulator. Connect the adjustable supply to the pilot port in the end of the cylinder (item 6).
2. Install a pressure gauge that reads up to 300-psi in the body cylinder port.
3. Install a 150-psi air supply in the normally open or normally close port.
4. Gradually increase or decrease the pressure, at the pilot port until the valve trips. When the valve trips read the pilot supply gage and make a note of the pressure.

## RAP R10: Air Relay Valve Service and Adjustment

ARV-69626/69627

05/05/11

# Air Relay Valve

---

5. To adjust the trip point, remove pressure on the pilot and rotate the adjusting cap (item 4) clockwise to increase or counter clockwise to decrease. Always remove pressure at the pilot before adjusting the adjusting cap.
6. Adjust the cap (item 4) and take pressure readings until the valve trips at the required pressure.
7. Tighten the locknut (item 5) to maintain the setting achieved.

If any further information is required, please feel free to contact:

Emerson Process Management  
Valve Automation Inc.  
2500 Park Avenue West  
Mansfield, Ohio 44906

Phone: (419) 529-4311

Fax: (419) 529-3688

Please visit our website for up to date product data. [www.shafervalve.com](http://www.shafervalve.com)

The contents of this publication are presented for informational purpose only, and while every effort has been made to ensure their accuracy, they are not to be construed as warranties or guarantees, express or implied, regarding the products or services described herein or their use or applicability. We reserve the right to modify or improve the designs or specifications of such products at any time with out notice.

# RAP R10: Air Relay Valve Service and Adjustment

ARV-69626/69627

05/05/11

## Air Relay Valve

