

Rosemount™ 648 Wireless Temperature Transmitter

with Rosemount X-well™ Technology



WirelessHART

Safety messages

Transmitter hardware revision	1
HART® device revision	4
Device install kit/device descriptor (DD) revision	Device Revision 4, DD Revision 1 or higher

⚠ WARNING

Read this manual before working with the product. For personal and system safety, and for optimum product performance, make sure to thoroughly understand the contents before installing, using, or maintaining this product.

⚠ WARNING

Follow instructions

Failure to follow these installation guidelines could result in death or serious injury.

Ensure only qualified personnel perform the installation.

⚠ WARNING

Explosions

Explosions could result in death or serious injury.

Installation of this transmitter in an explosive environment must be in accordance with the appropriate local, national, and international standards, codes, and practices. Review the approvals section of the [Quick Start Guide](#) for any restrictions associated with a safe installation.

Before connecting a handheld communicator in an explosive atmosphere, ensure the instruments in the segment are installed in accordance with intrinsically safe or non-incendive field wiring practices.

⚠ WARNING

Process leaks

Process leaks could result in death or serious injury.

Install and tighten process connectors before applying pressure.

⚠ WARNING

Electrical shock

Electrical shock could cause death or serious injury.

Avoid contact with the leads and terminals. High voltage that may be present on leads can cause electrical shock.

⚠ WARNING

Physical access

Unauthorized personnel may potentially cause significant damage to and/or misconfiguration of end users' equipment. This could be intentional or unintentional and needs to be protected against.

Physical security is an important part of any security program and fundamental in protecting your system. Restrict physical access by unauthorized personnel to protect end users' assets. This is true for all systems used within the facility.

NOTICE

The Rosemount 648 Wireless and all other wireless devices should be installed only after the Wireless Gateway has been installed and is functioning properly. Wireless devices should also be powered up in order of proximity from the Wireless Gateway, beginning with the closest. This will result in a simpler and faster network installation.

NOTICE

Shipping considerations for wireless products (lithium batteries: Black Power Module, model number 701PBKKF):

The unit was shipped to you without the power module installed. Remove the power module prior to shipping the unit. Each Black Power Module contains two "C" size primary lithium-thionyl chloride battery. Primary lithium batteries are regulated in transportation by the U. S. Department of Transportation, and are also covered by IATA (International Air Transport Association), ICAO (International Civil Aviation Organization), and ARD (European Ground Transportation of Dangerous Goods). It is the responsibility of the shipper to ensure compliance with these or any other local requirements. Consult current regulations and requirements before shipping.

NOTICE

Power Module Considerations (Black Power Module, model number 701PBKKF):

The Black Power Module with the wireless unit contains two "C" size primary lithium-thionyl chloride battery (model number 701PGNKF). Each battery contains approximately 2.5 grams of lithium, for a total of 5 grams in each pack. Under normal conditions, the battery materials are self-contained and are not reactive as long as the batteries and the pack integrity are maintained. Care should be taken to prevent thermal, electrical or mechanical damage. Contacts should be protected to prevent premature discharge. Battery hazards remain when cells are discharged. Power modules should be stored in a clean and dry area. For maximum power module life, storage temperature should not exceed 30 °C.

NOTICE

The products described in this document are NOT designed for nuclear-qualified applications.

Using non-nuclear qualified products in applications that require nuclear-qualified hardware or products may cause inaccurate readings.

For information on Rosemount nuclear-qualified products, contact a Emerson Sales Representative.

NOTICE

This device complies with Part 15 of the Federal Communication Commission (FCC) Rules. Operation is subject to the following conditions:

This device may not cause harmful interference.

This device must accept any interference received, including interference that may cause undesired operation.

This device must be installed to ensure a minimum antenna separation distance of 8-in. (20 cm) from all persons.

The power module may be replaced in a hazardous area. The power module has surface resistivity greater than one gigaohm and must be properly installed in the wireless device enclosure. Care must be taken during transportation to and from the point of installation to prevent electrostatic charge build-up.

Contents

Chapter 1	Introduction.....	7
	1.1 Product recycling/disposal.....	7
Chapter 2	Configuration.....	9
	2.1 Overview.....	9
	2.2 Sensor connections.....	10
	2.3 Bench top configuration.....	14
	2.4 HART® menu tree.....	16
	2.5 Fast key sequences.....	19
	2.6 Basic setup.....	20
	2.7 Calibration.....	23
	2.8 Advanced setup.....	25
	2.9 Remove power module.....	31
Chapter 3	Installation.....	33
	3.1 Overview.....	33
	3.2 Wireless considerations.....	33
	3.3 Physical installation.....	35
	3.4 Ground the transmitter.....	39
Chapter 4	Commissioning.....	43
	4.1 Overview.....	43
	4.2 Verify operation.....	44
Chapter 5	Operation and maintenance.....	47
	5.1 LCD display screen messages.....	47
	5.2 Power module replacement.....	55
Chapter 6	Troubleshooting.....	57
	6.1 Overview.....	57
	6.2 Device status.....	57
	6.3 Transmitter output.....	61
	6.4 LCD display.....	62
	6.5 Wireless network.....	62
Appendix A	Reference data.....	65
	A.1 Ordering information, specifications, and drawings.....	65
	A.2 Product certifications.....	65
Appendix B	Mapping for Non device descriptor (DD) based integration with host systems.....	67
	B.1 Alert message mapping.....	67
	B.2 Mapping device variable index numbers.....	68

1 Introduction

1.1 Product recycling/disposal

Consider recycling equipment and packaging.

Dispose of the product and packaging in accordance with local and national legislation.

2 Configuration

2.1 Overview

This section contains information on configuration and verification that should be performed prior to installation. Communication device and AMS Device Manager instructions are given to perform configuration functions. For convenience, communication device Fast Key sequences are labeled “Fast Keys” for each software function below the appropriate headings.

Sensor input trim example

Fast Keys sequence	1,2,3, etc.
--------------------	-------------

2.2 Sensor connections

The transmitter is compatible with a number of RTD and thermocouple sensor types. [Figure 2-1](#) shows the correct input connections to the sensor terminals on the transmitter. To ensure a proper sensor connection, anchor the sensor lead wires into the appropriate compression terminals and tighten the screws.

Make sensor connections through the cable entry in the side of the connection head. Be sure to provide adequate clearance for cover removal.

When using Rosemount X-well Technology, the transmitter must be assembled to a Rosemount 0085 Pipe Clamp RTD Sensor in a direct mount 3-wire configuration.

Thermocouple or millivolts inputs

The thermocouple can be connected directly to the transmitter. Use appropriate thermocouple extension wire if mounting the transmitter remotely from the sensor.

RTD or ohm inputs

The wireless transmitter will accept a variety of RTD or ohmic configurations, including 2-, 3-, or 4-wire connections. If the transmitter is mounted remotely using a 3- or 4-wire connection, it will operate withing specifications without recalibration for lead wire resistances of up to 5 ohms per lead (equivalent to 500 ft. [152.4 m] of 20 AWG wire). In this case, Emerson recommends shielding the leads between the RTD and the transmitter.

2.2.1 Sensor lead wire resistance effect—RTD input

Since the lead wires are part of the RTD circuit, the lead wire resistance needs to be compensated to achieve the best accuracy. This becomes especially critical in applications where long sensor and/or lead wires are used. There are three lead wire configurations commonly available.

A 4-wire design is ideal because the lead wire resistance is inconsequential to the measurement. It uses a measurement technique where a very small constant current of about 150 micro amps is applied to the sensor through two leads and the voltage developed across the sensor is measured over the other two wires with a high-impedance and high resolution measuring circuit. In accordance with Ohm's Law, the high impedance virtually eliminates any current flow in the voltage measurement leads and therefore the resistance of the leads is not a factor.

In a 3-wire configuration, compensation is accomplished using the third wire with the assumption that it will be the same resistance as the other two wires and the same compensation is applied to all three wires.

In a 2-wire configuration there can be no compensation for lead wire resistance since the lead wires are in series with the element and appear to the transmitter as part of the sensor's resistance causing inherent accuracy degradation.

Table 2-1: Examples of Approximate Basic Error

Sensor input	Approximate basic error
4-wire RTD	Negligible ⁽¹⁾
3-wire RTD	Error in reading is equivalent to unbalanced lead wire resistance ⁽²⁾
2-wire RTD	Error in reading equivalent total lead wire resistance

(1) Independent of lead wire resistance up to 5Ω per lead.

(2) Unbalanced lead wire resistance is the maximum resistance differences between any of two leads.

Figure 2-1: Sensor wiring

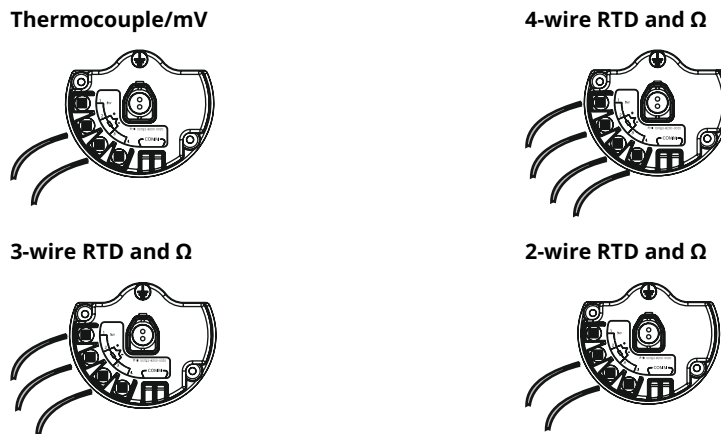
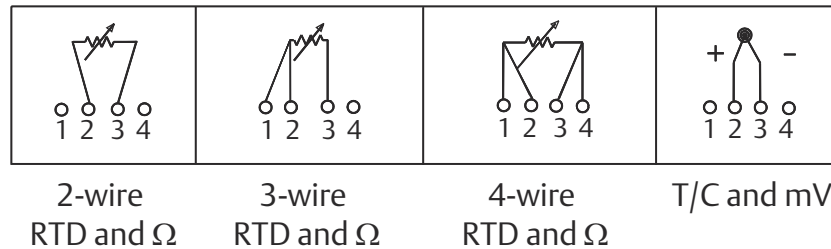

Figure 2-2: Sensor Connections



Note

Emerson provides 4-wire sensors for all single element RTDs. Use these RTDs in 3-wire configurations by leaving the unneeded leads disconnected and insulated with electrical tape.

2.2.2 Lead wire configuration

Figure 2-3: Rosemount 68Q, 78 standard temperature range, and 58 RTD sensor single element

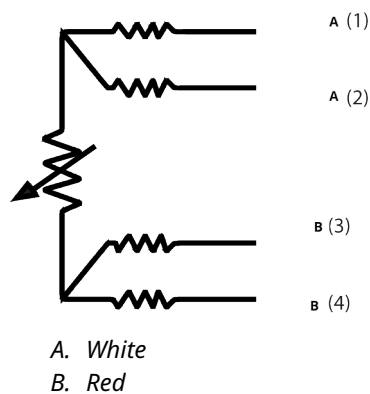
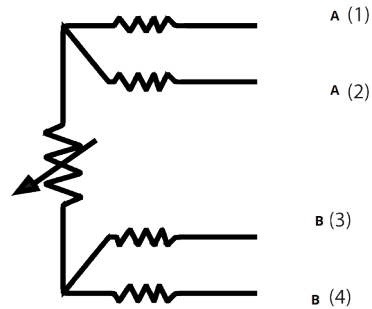

Figure 2-4: Rosemount 65, 78 High Temp, 68 RTD Single Element



A. White
B. Red

Figure 2-5: Rosemount 183 Thermocouple

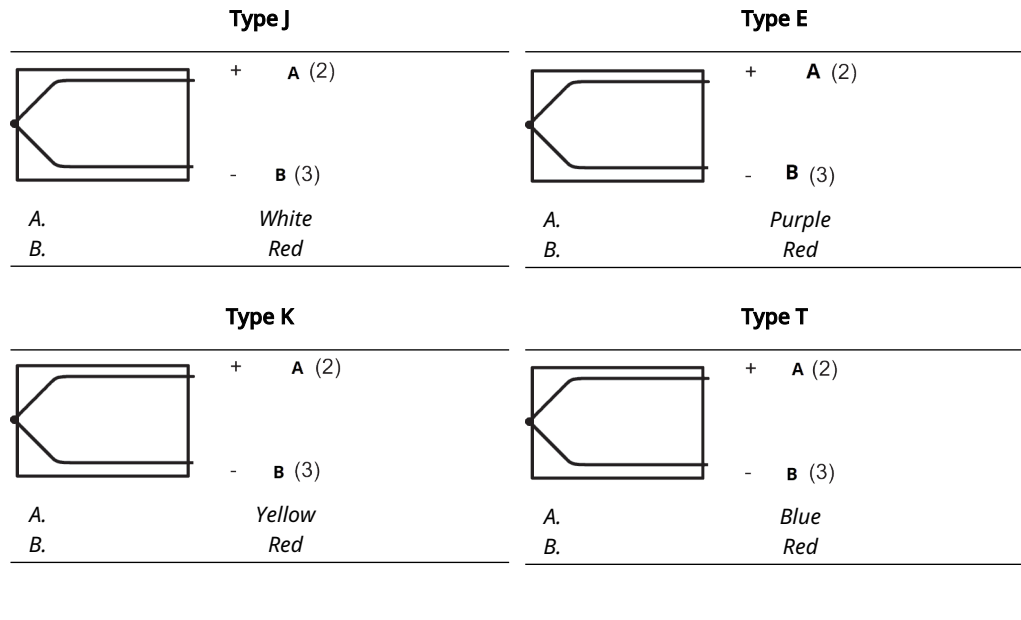
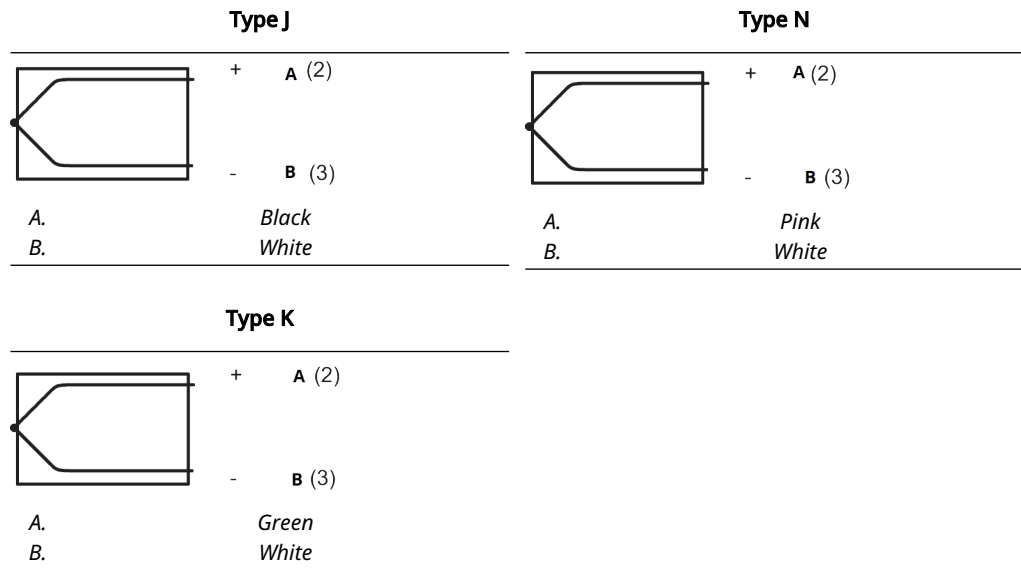

Figure 2-6: Rosemount 185 Thermocouple



Note

Wire color examples apply to Rosemount sensors, but will vary by manufacturer.

2.2.3 Wire sensor

⚠ WARNING

If the sensor is installed in a high-voltage environment and a fault condition or installation error occurs, the sensor leads and transmitter terminals could carry lethal voltages.

Use extreme caution when making contact with the leads and terminals.

Use the following steps to wire the sensor and supply power to the transmitter:

1. Remove the transmitter enclosure cover (if applicable).
2. Attach the sensor leads according to the wiring diagrams.
3. Connect the power module.
4. Verify the connection by observing the LCD display (if applicable).
5. Reattach and tighten the cover (if applicable).

2.3 Bench top configuration

Bench top configuration consists of testing the transmitter and verifying transmitter configuration data.

The transmitter must be configured before installation, which may be performed either directly or remotely. Direct configuration can be performed using a communication device, AMS Device Manager, AMS Wireless Configurator, or any *WirelessHART*[®] Communicator. Remote configuration can be performed using AMS Device Manager, AMS Wireless Configurator, or the Wireless Gateway.

The power module must be installed to provide power to the transmitter for configuration. To communicate to the transmitter, begin by removing the power module-side housing cover, indicated as **Field terminals** by text located on the side of the device. This will expose the terminal block and HART[®] Communication terminals, which are labeled **COMM**. Connect the power module to supply power for configuration. See [Figure 2-7](#).

Figure 2-7: Connection Diagram for transmitter and communication device

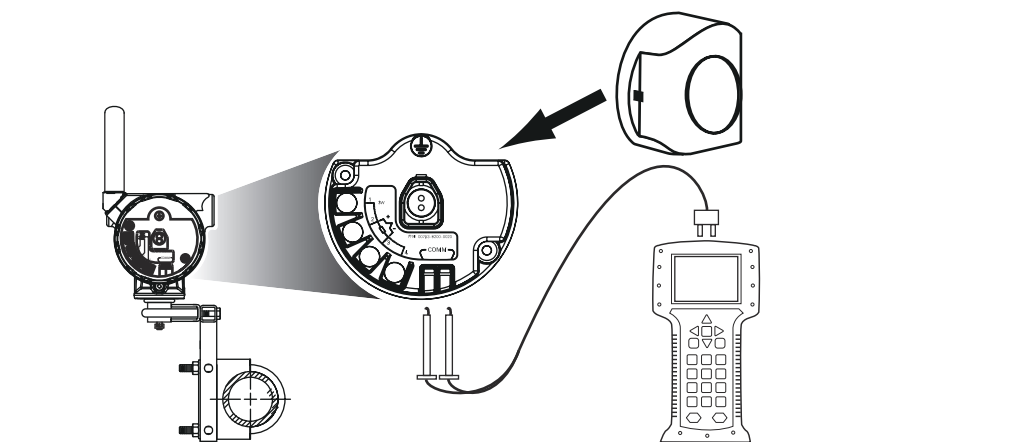

2.3.1 Communication Device

When performing transmitter configuration directly, connect the bench equipment as shown in [Figure 2-7](#) above, press the Communication Device **ON/OFF** key.

When using a communication device, any configuration changes must be sent to the transmitter by using the **Send** key (**F2**).

The communication device will search for a HART[®]-compatible device and indicate when the connection is made. If the communication device fails to connect, it will indicate that no device was found. If this occurs, refer to [Troubleshooting](#).

Note

For HART Wireless transmitter communication via a communication device, a 648 Wireless Device descriptor (DD) is required. 648 Wireless Transmitters equipped with Rosemount X-well Technology requires DD revision 648 Dev. 4 Rev. 1 or higher to view X-well functionality. To obtain the latest DD, visit [Software & Drivers](#).

2.3.2 AMS Device Manager and AMS Wireless Configurator

When configuring the transmitter using AMS Device Manager or AMS Wireless Configurator, double click the transmitter device icon (or right click and select **Configure/Setup**) and then select the **Configure/Setup** tab.

AMS Device Manager configuration changes are implemented when the **Apply** button is selected.

Note

For HART® Wireless transmitter communication via AMS Device Manager, a 648 Wireless Device descriptor (DD) is required. Transmitters equipped with Rosemount X-well Technology requires DD revision 648 Dev. 4 Rev. 1 or higher to view X-well functionality. To obtain the latest DD, visit the [Software & Drivers](#).

2.3.3 Wireless Gateway

The transmitter supports limited remote configuration through the Wireless Gateway. The Gateway allows configuration of the following device parameters: HART Tag, Short Tag, Descriptor, Engineering Units, Update Rate and Range Values.

2.3.4 Default settings

The transmitter default configuration is shown below:

Sensor type	Pt 100 ($\alpha = 0.00386$)
Engineering units	°C
Number of lead wires	4
Network ID	Factory-generated network parameters
Join Key	Factory-generated network parameters
Update rate	1 minute

Note

The C1 option code can be used to enable factory configuration of the **Update Rate**, **Date**, **Descriptor** and **Message** fields. This code is not required to have the factory configure the **Sensor Type**, **Connection** or the **Self Organizing Network** parameters.

2.3.5 Device sensor configuration

Every temperature sensor has unique characteristics. In order to ensure the most accurate measurement, the configure the transmitter to match the specific sensor that it will be connected to.

Prior to installation, verify the configuration and connection settings of the temperature sensor through a communication device or AMS Device Manager.

2.4 HART® menu tree

This section displays the navigation paths to the primary commands and options via a communication device.

For HART Wireless transmitter communication via a communication device, a Wireless Device descriptor (DD) is required. 648 Wireless Transmitters with X-well Technology requires DD revision Dev. 4 Rev.1 or higher to view X-well functionality. To obtain the latest DD, visit the [Software & Drivers](#).

Figure 2-8: Overview

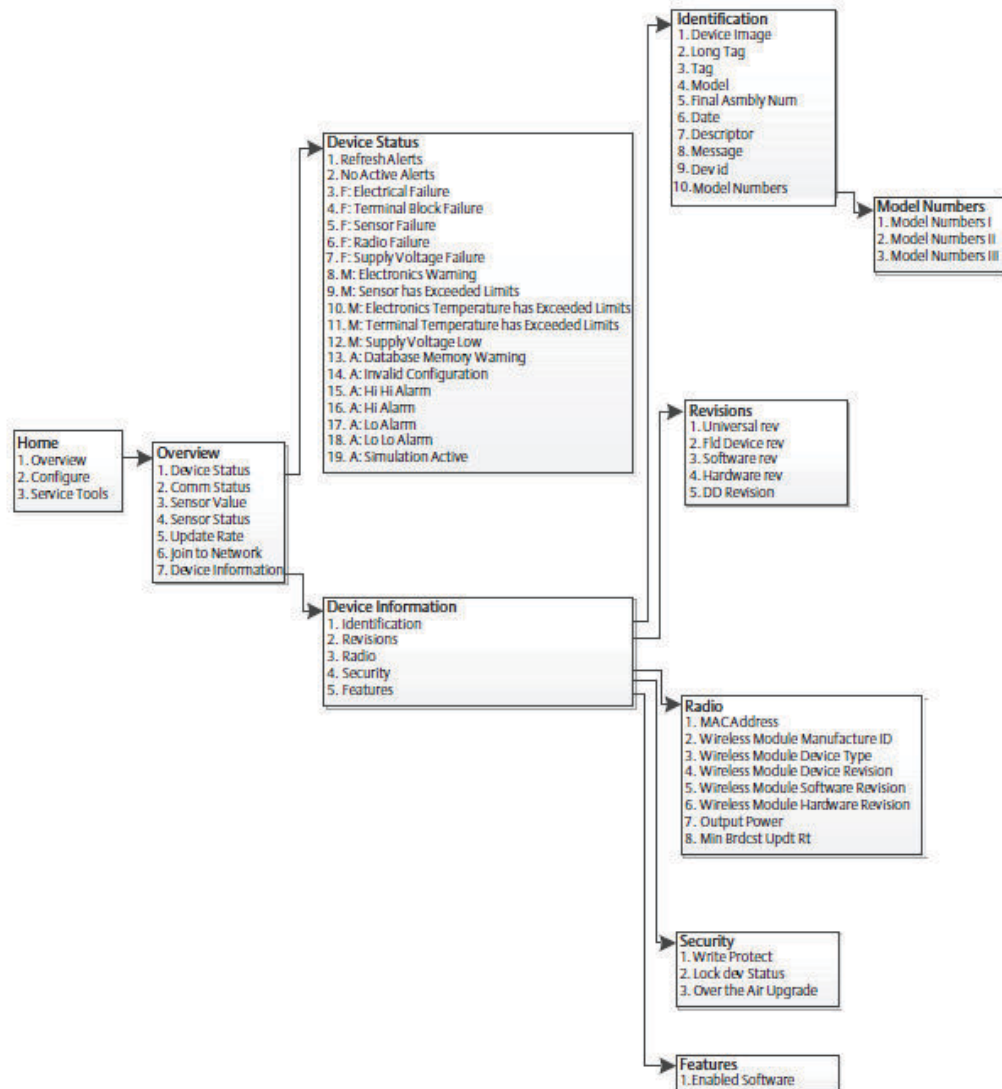

Figure 2-9: Configure

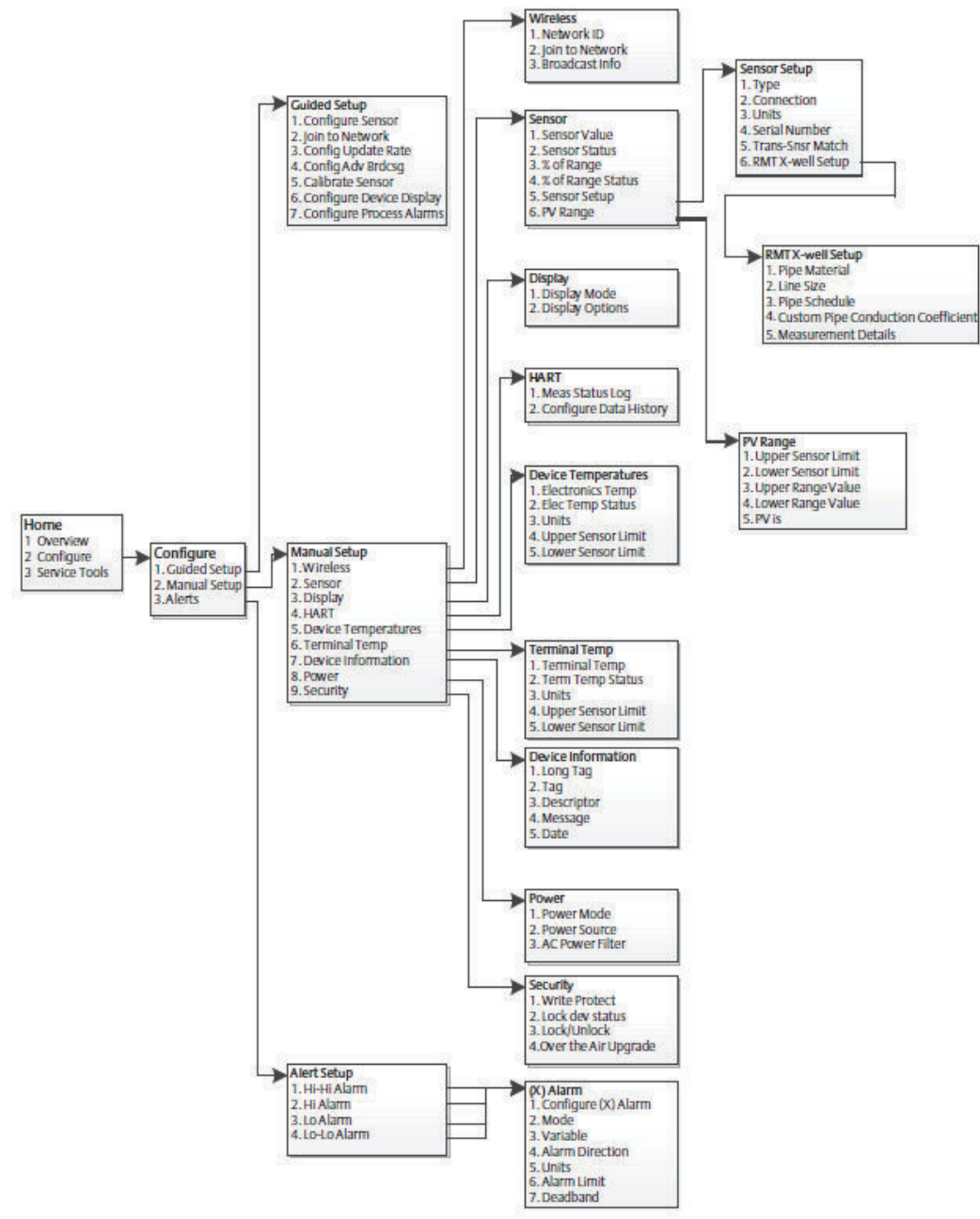
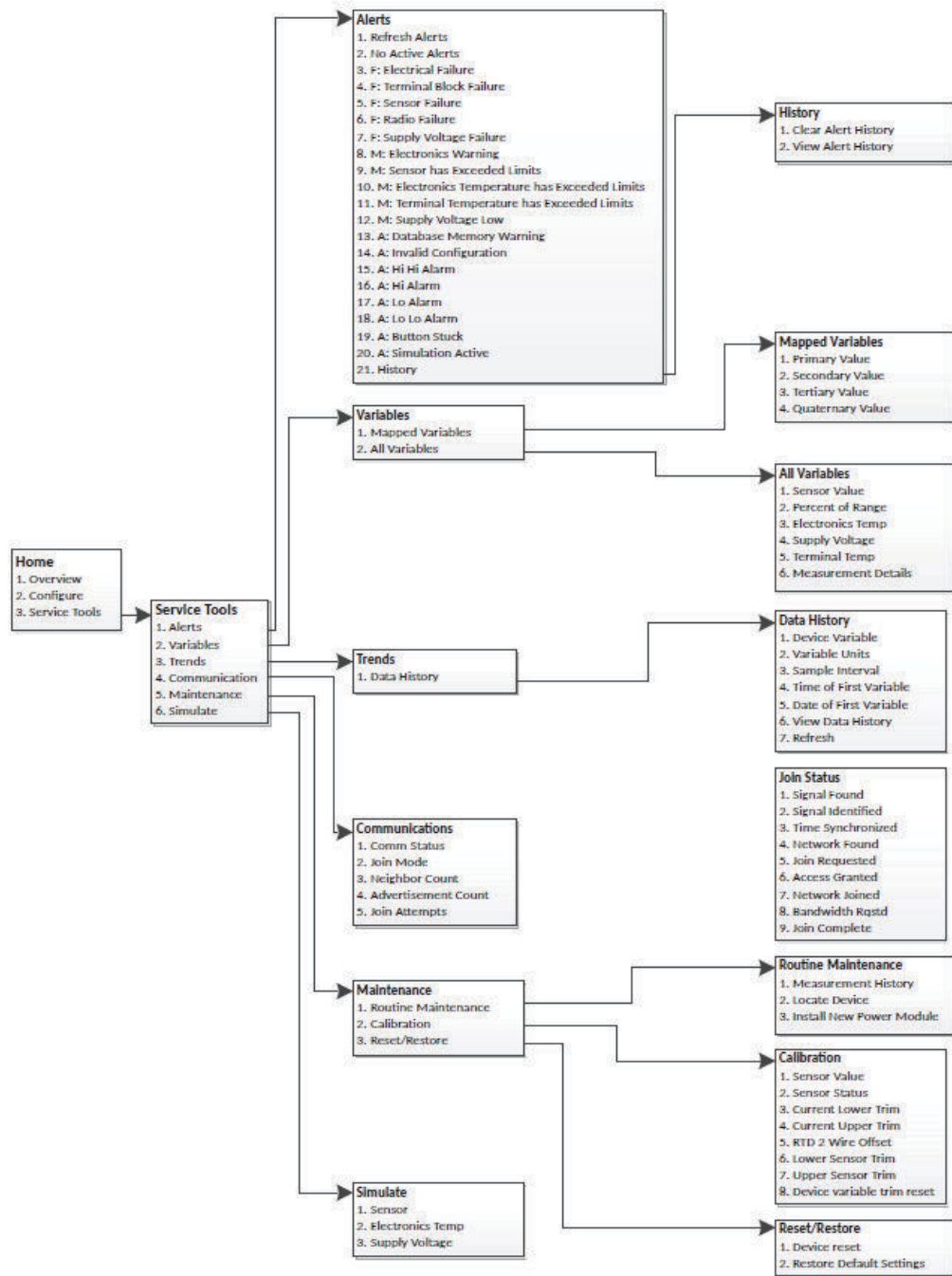

Figure 2-10: Service Tools



2.5 Fast key sequences

Table 2-2 lists the fast key sequences for common transmitter functions.

Note

The fast key sequences assumes that the latest device descriptor (DD) is being used. The latest DD revision can be found in the front matter of this document.

Table 2-2: Fast key sequences

Function	Fast key sequence	Menu items
<i>Device Information</i>	2, 2, 7	<ul style="list-style-type: none"> • Tag • Long Tag • Descriptor • Message • Date
<i>Guided Setup</i>	2, 1	<ul style="list-style-type: none"> • Configure Sensor • Join to Network • Config Advance Broadcasting • Calibrate Sensor
<i>Manual Setup</i>	2, 2	<ul style="list-style-type: none"> • Wireless • Sensor • Display • HART • Device Temperature • Terminal Temperature • Device Information • Power • Security
<i>Sensor Calibration</i>	3, 5, 2	<ul style="list-style-type: none"> • Sensor Value • Sensor Status • Current Lower Trim • Current Upper Trim • RTD 2 Wire Offset • Lower Sensor Trim • Upper Sensor Trim • Device Variable Trim Reset

Table 2-2: Fast key sequences (continued)

Function	Fast key sequence	Menu items
<i>Sensor Configuration</i>	2, 2, 2, 5	<ul style="list-style-type: none"> • Type • Connection • Units • Serial Number • Transmitter - Sensor Matching • RMT X-well Setup
<i>Wireless Configuration</i>	2, 2, 1	<ul style="list-style-type: none"> • Network ID • Join to Network • Broadcast Info

2.6 Basic setup

2.6.1 Configure sensor type

Every temperature sensor has unique characteristics to achieve the most accurate measurement. Configure the wireless transmitter to match the specific sensor type.

Fast keys 2, 1, 1

Procedure

1. From the **Home** screen, select **2: Configure**.
2. Select **1: Guided Setup**
3. Select **1: Configure Sensor**
4. Follow on the on-screen instructions to complete the configuration.

This method involves selecting the number of lead wires and temperature engineering units for the sensor.

2.6.2 Join device to network

To communicate with the Wireless Gateway and ultimately the host system, configure the transmitter to communicate over the wireless network. This step is the wireless equivalent of connecting wires from a transmitter to the host system.

Fast keys 2, 1, 2

Procedure

1. From the **Home** screen, select **2: Configure**.
2. Select **1: Guided Setup**.
3. Select **2: Join to Network**.
4. Using a communication device or AMS Device Manager to communicate with the transmitter, enter the **Network ID** and **Join Key** so they match the **Network ID** and **Join Key** of the Wireless Gateway and the other devices in the network.

Note

If the **Network ID** and **Join Key** are not identical to those set in the Gateway, the transmitter will not communicate with the network. To obtain the **Network ID** and **Join Key**, go to **System Settings** → **Network** → **Network Settings** on the Wireless Gateway web based user interface.

Figure 2-11: Wireless Gateway Network Settings page

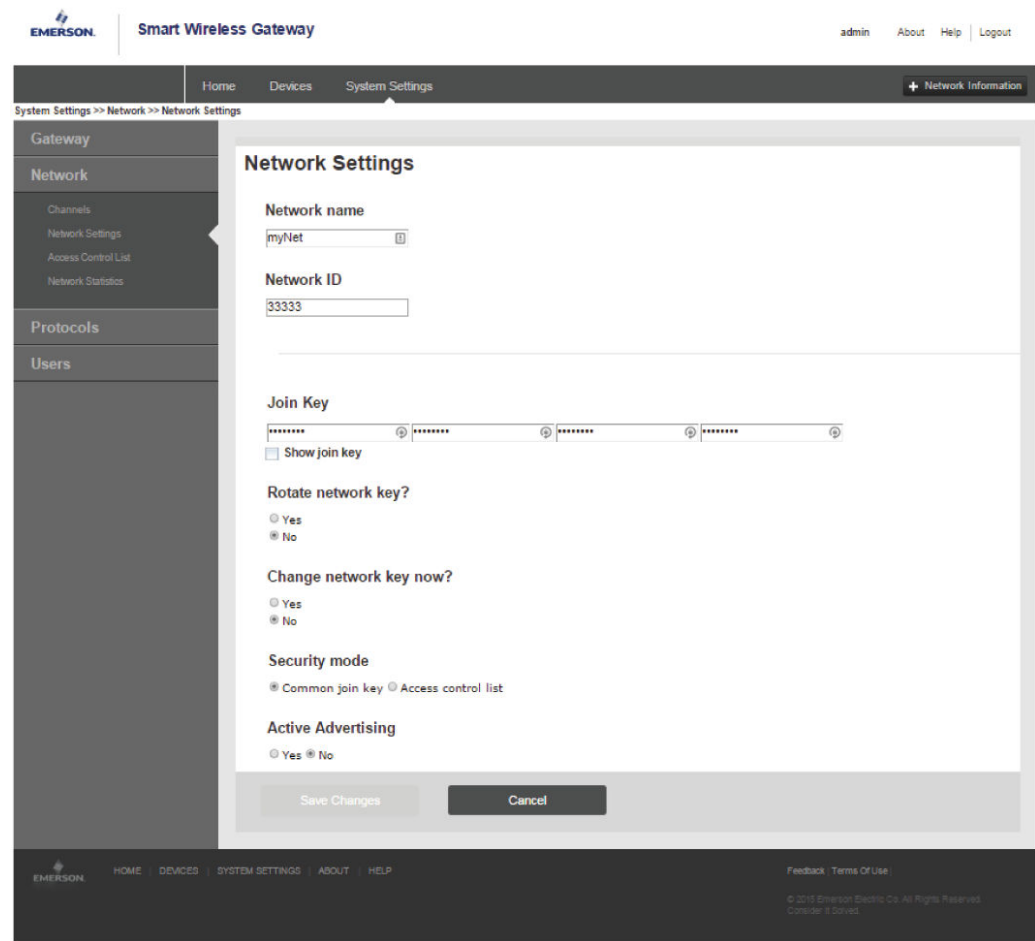

2.6.3 Configure update rate

The update rate is the frequency at which a new measurement is taken and transmitted over the wireless network. This by default is one minute. You can change the update rate at any time using AMS Device Manager. The update rate is user selectable from one second to 60 minutes.

Fast keys 2, 1, 3

Procedure

1. From the *Home* screen, select **2: Configure**.
2. Select **1: Guided Setup**.
3. Select **3: Configure Update Rate**.
4. When the device configuration is completed, remove the power module and replace the module cover.

Postrequisites

NOTICE

Only insert the power module when the device is ready to be commissioned. Use caution when handling the power module.

Figure 2-12: Terminal block

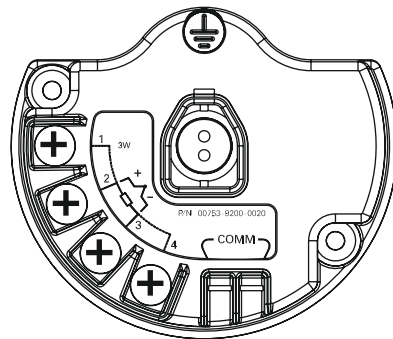

Connect the HART® communication leads to the **COMM** terminals on the terminal block.

Figure 2-13: Communication device connections

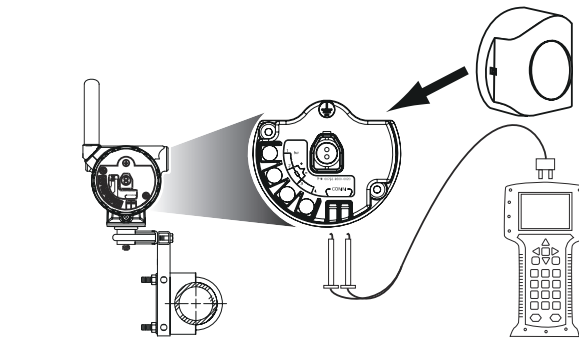

2.7 Calibration

Calibrating the transmitter increases the measurement precision by making corrections to the factory-stored characterization curve by digitally altering the transmitter's interpretation of the sensor input.

To understand calibration, it is necessary to understand that smart transmitters operate differently from analog transmitters. An important difference is that smart transmitters are factory-characterized, meaning that they are shipped with a standard sensor curve stored in the transmitter firmware. In operation, the transmitter uses this information to produce a process variable output, in engineering units, dependent on the sensor input.

Calibration of the wireless transmitter may include the following procedures:

Sensor input trim	Digitally alter the transmitter's interpretation of the input signal
Transmitter-sensor matching	Generates a special custom curve to match that specific sensor curve, as derived from the Callendar-Van Dusen constants.

2.7.1 Perform sensor input trim

Perform a sensor trim if the transmitters digital value for the primary variable does not match the plant's standard calibration equipment. The sensor trim function calibrates the sensor to the transmitter in temperature units or raw units. Unless your site-standard input source is National Institute of Standards and Technology (NIST)-traceable, the trim functions will not maintain the NIST-traceability of the system.

Fast key sequence 3, 5, 2

The `SENSOR INPUT TRIM` command allows the transmitter's interpretation of the input signal to be digitally altered. The sensor reference command trims, in engineering (°F, °C, °R, K) or raw (Ω , mV) units, the combined sensor and transmitter system to a site standard using a known temperature source. Sensor trimming is suitable for validation procedures or for applications that require calibrating the sensor and transmitter together.

Procedure

1. Connect the calibration device or sensor to the transmitter.
Refer to [Figure 2-1](#) or the device terminal block for sensor wiring diagrams.
2. Connect the communication device to the transmitter.
3. From the **Home** screen, select **3 Service Tools** → **5 Maintenance** → **2 Calibration** to prepare to trim the sensor.
4. Select **6 Lower Sensor Trim** or **7 Upper Sensor Trim**.

Note

Emerson recommends performing lower offset trims first, before performing upper slope trims.

5. Answer the question about using an active calibrator or not.
6. Adjust the calibration device to the desired trim value (must be within the selected sensor limits). If a combined sensor and transmitter system is being trimmed, expose the sensor to a known temperature and allow the temperature reading to stabilize. Use a bath, furnace, or isothermal block, measured with a site-standard thermometer, as the known temperature source.
7. Select **OK** once the temperature stabilizes.

The communication device displays the output value the transmitter associates with the input value provided by the calibration device.

8. Select the appropriate sensor trim units at the prompt.
9. Enter the trim point.

2.7.2 Transmitter-sensor matching

Perform the transmitter-sensor matching procedure to enhance the temperature measurement accuracy of the system (see [Figure 2-14](#)) if you have a sensor with Callendar-Van Dusen constants. When ordered from Emerson, sensors with Callendar-Van Dusen constants are National Institute of Standards and Technology (NIST)-traceable.

Fast keys 2, 1, 1

The wireless transmitter accepts Callendar-Van Dusen constants from a calibrated RTD schedule and generates the actual curve to match that specific sensor curve.

Figure 2-14: Standard vs. actual sensor curve

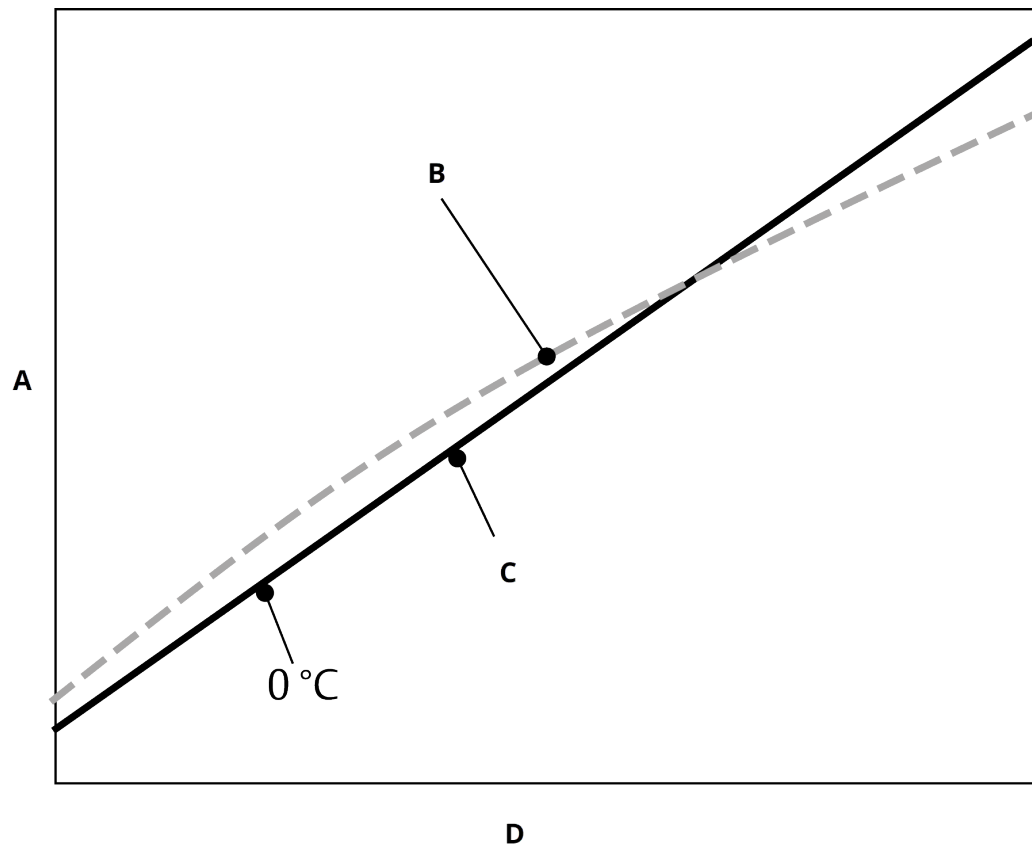

- A. Resistance, Ohm
- B. Standard IEC 751 ideal curve
- C. Actual curve⁽¹⁾
- D. Temperature, °C

⁽¹⁾ The actual curve is identified from the Callendar-Van Dusen equation.

Table 2-3: System accuracy comparison at 302 °F (150 °C) using a PT 100 (A=0.00385) RTD with a span of 32 to 392 °F (0 to 200 °C)

Standard RTD		Matched RTD	
Wireless	±0.45 °C	Wireless	±0.45 °C
Standard RTD	±1.05 °C	Matched RTD	±0.18 °C
Total System ⁽¹⁾	±1.14 °C	Total System ⁽¹⁾	±0.48 °C

(1) Calculated using root-summed-squared (RSS) statistical method.

Total system accuracy = (Transmitter accuracy)² + (Sensor accuracy)²

Input Callendar-Van Dusen constants

$$R_t = R_o + R_{\alpha\alpha} [t - \delta(0.01t-1)(0.01t) - \beta(0.01t - 1)(0.01t)^3]$$

The following input variables, included with specially-ordered Rosemount temperature sensors, are required:

R_o = Resistance at Ice Point Alpha = Sensor Specific Constant Beta = Sensor Specific Constant Delta = Sensor Specific Constant

To input Callendar-Van Dusen constants:

Procedure

1. From the **Home** screen, select **2 Configure** → **1 Guided Setup** → **1 Configure Sensor** → **1 Configure Type and Units** and press **Enter**.
2. Select **Cal VanDusen** at the **Select Sensor Type** prompt.
3. Select the appropriate number of wires at the **Select Sensor Connection** prompt.
4. Enter the R_o, Alpha, Delta, and Beta values from the stainless steel tag attached to the special-order sensor when prompted.
5. Select desired other options and select **Enter**.
6. To disable the transmitter-sensor matching feature from the **Home** screen select **Configure** → **Guided Setup** → **Configure Sensor** → **Configure Sensor Type and Units** and press **Enter**. Select the appropriate sensor type from the **Select Sensor type** prompt.

Note

When the transmitter-sensor matching is disabled, the transmitter reverts to factory trim. Ensure the transmitter engineering units default correctly before placing the transmitter into service.

2.8 Advanced setup

2.8.1 LCD display

The **LCD display configuration** command allows customization of the LCD display to suit application requirements.

The LCD display will alternate between the selected items:

- **Temperature units**
- **Sensor temperature**

- **% of range**
- **Supply voltage**

Related information

[LCD display screen messages](#)

Configuring LCD display with Communication Device

Fast keys 2, 1, 6

Transmitter ordered with the LCD display will be shipped with display installed and enabled.

If the transmitter was ordered without the LCD display or if the LCD display was disabled, follow these steps to enable the LCD display on the transmitter.

Procedure

1. From the **Home** screen, select **2: Configure**.
2. Select **1: Guided Setup**.
3. Select **6: Configure Device Display**.
4. Select the **Periodic** option.
5. Select desired display options and select **Enter**.

Configuring LCD display with AMS Device Manager

Procedure

1. Right click on the device and select **Configure**.
2. Under **Optional Setup**, select **Configure Device Display** button.
3. Select desired display options and select **Enter**.

Note

The LCD display can be order as a spare part with part number: 00753-9004-0002.

2.8.2 Rosemount X-well technology

The 648 Wireless can be ordered with X-well technology via the **PT** model option code.

The **C1** model option code must be ordered if the **PT** option code is specified. The **C1** option code requires user supplied information of process pipe material and pipe schedule. Rosemount X-well technology can be configured with any asset management software that supports Electronic Device Description Language (EDDL). The Device Dashboard interface with DD revision 648 Dev. 4 Rev. 1 or higher is required to view Rosemount X-well functionality.

The **Rosemount X-well Process** sensor/type option should be selected as the sensor type in most cases. Once selected, pipe material, line size, and pipe schedule information is required when configuring Rosemount X-well technology. This section is referring to the process pipe properties that Rosemount 648 Wireless and 0085 Pipe Clamp Sensor with Rosemount X-well technology is going to be installed in. This information is required for the in-transmitter algorithm to accurately calculate process temperature.

In the rare case that the process pipe is not available, a custom value for the pipe conduction coefficient can be entered. This field becomes available when the **Rosemount X-well Custom** sensor/type option is selected.

Configure Rosemount X-well technology with Communication Device

Procedure

1. From the *Home* screen, select **2: Configure**.
2. Select **1: Guided Setup**.
3. Select **1: Configure Sensor**.
4. Select **1: Configure Sensor Type and Units**.
5. Select either **Rosemount X-well Process** or **Rosemount X-well Custom**.
6. Select configurations and select **Enter**.

Configure Rosemount X-well technology with AMS Device Manager

Procedure

1. Right click on the device and select **Configure**.
2. In the menu tree, select **Manual Setup**.
3. Select the **Sensor** tab.
4. Select either **Rosemount X-well Process** or **Rosemount X-well Custom**.
5. Select configurations and select **Send**.

Figure 2-15: Manual Setup - Sensor Screen for the Rosemount 648 Wireless with Rosemount X-well Technology

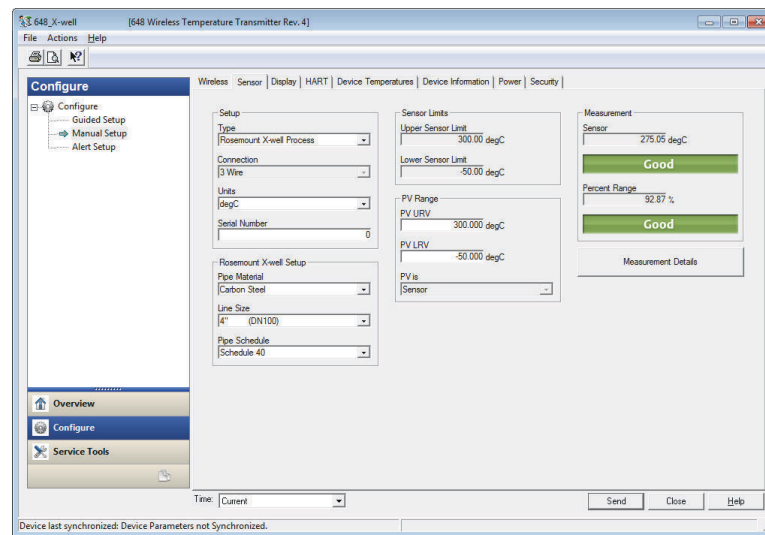

View X-well measurement details

Perform the following procedure to view live and trend data and trending for:

- Measuring ambient temperature
- Measured surface temperature
- Calculated process temperature

Procedure

1. Right click on the device and select **Configure**.
2. In the menu tree, select **Manual Setup**.
3. Select the **Sensor** tab.
4. Select the **Measurement Details** button.

Figure 2-16: Rosemount X-well Measurement Details Page

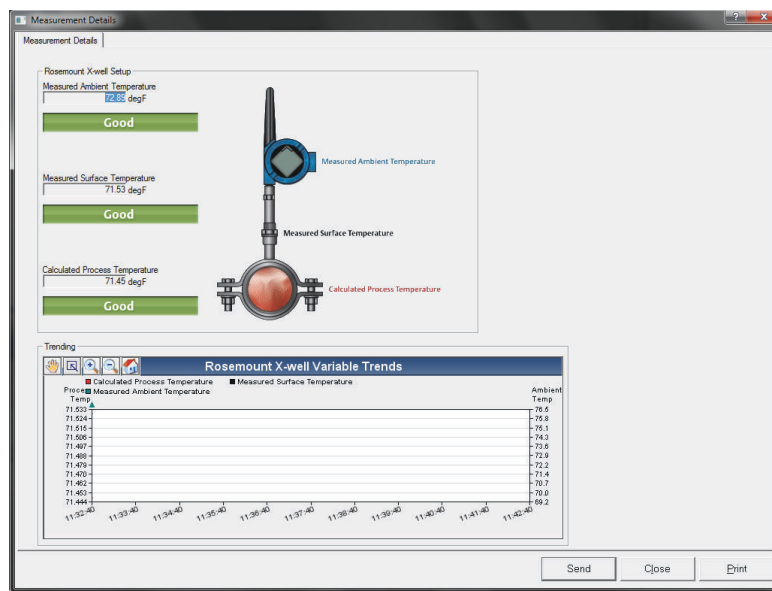

2.8.3 Process alerts

Fast keys 2, 1, 7

Process alerts allow you to configure the transmitter to output a HART® message when the configured data point is exceeded. An alert will be transmitted continuously if the set points are exceeded and the alert mode is **ON**. An alert will be displayed on a Communication Device, AMS Device Manager **status** screen or in the **error** section of the LCD display. The alert will reset once the value returns within range.

Note

HI alert value must be higher than the **LO alert** value. Both alert values must be within the temperature sensor limits.

Figure 2-17: Example 1: Rising Alert

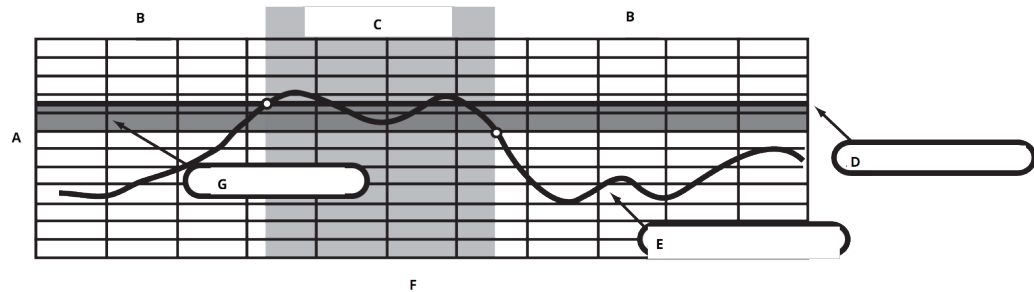

- A. Units of measurement
- B. Alert **OFF**
- C. Alert **ON**
- D. Alert set point
- E. Assigned value
- F. Time
- G. Deadband

Figure 2-18: Example 2: Falling Alert

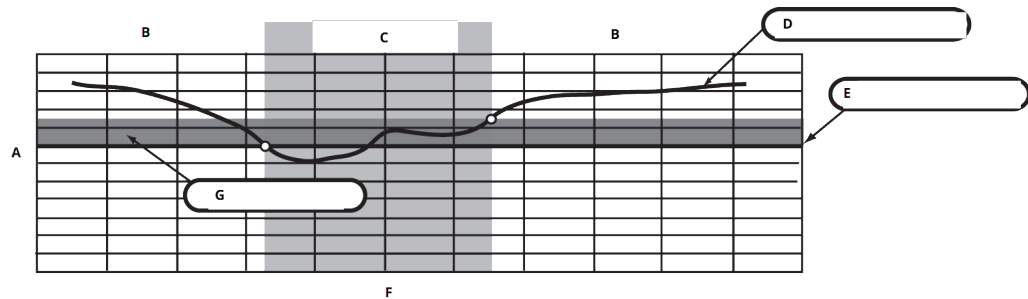

- A. Units of measurement
- B. Alert **OFF**
- C. Alert **ON**
- D. Assigned value
- E. Alert set point
- F. Time
- G. Deadband

Configure process alerts using a Communication Device

To configure the process alerts with a Communication Device:

Procedure

1. From the **HOME** screen, go to **2 Configure** → **1 Guided Setup** → **1 Guided Setup**.
2. Select one of the following:
 - **2** for **Hi-Hi Alarm**
 - **3** for **Hi Alarm**
 - **4** for **LO Alarm**

- 5 for **LO-LO Alarm**
3. Press **Enter**.
 4. If the alarm is disabled, select **1 Enable** and press **Enter**. If the alarm was previously enabled, select **2 Leave Enabled** and press **Enter**.
 5. Enter the **alarm limit** and press **Enter**.
 6. Enter the **alarm deadband** and press **Enter**.

2.9 Remove power module

After the sensor and network have been configured, remove the Power Module and replace the transmitter cover. The Power Module should be inserted only when the device is ready to be commissioned. Use caution when handling the Power Module. The Power Module may be damaged if dropped from heights in excess of 20 ft. (6.1 m).

3 Installation

3.1 Overview

The information in this section covers installation considerations. The [Rosemount Wireless Product Data Sheet](#) includes instructions on how to access Dimensional drawings for each Wireless variation and mounting configuration.

3.2 Wireless considerations

3.2.1 Power up sequence

The Rosemount Wireless and all other wireless devices should be installed only after the Wireless Gateway ("Gateway") has been installed and is functioning properly. Wireless devices should also be powered up in order of proximity from the Gateway, beginning with the closest. This will result in a simpler and faster network installation. Enable active advertising on the Gateway to ensure new devices join the network faster. For more information, see the Wireless Gateway [Reference Manual](#).

3.2.2 Antenna position

Position the antenna vertically, either straight up or straight down, and approximately 3 ft. (1 m) from any large structure, building, or conductive surface to allow for clear communication to other devices.

Figure 3-1: Antenna Position

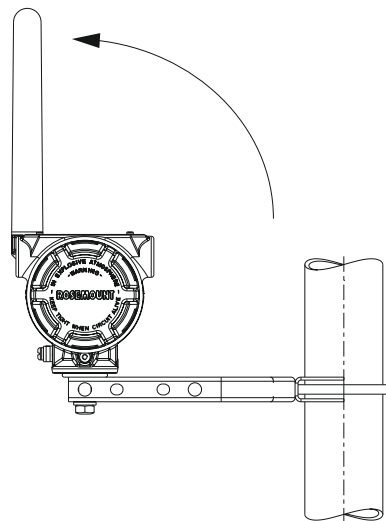

3.2.3 Conduit entry

Upon installation, ensure each conduit entry is either sealed with a conduit plug using approved thread sealant, or has an installed conduit fitting or cable gland with appropriate threaded sealant.

Note

The conduit entries are threaded ½-14 NPT.

Figure 3-2: Conduit Entry

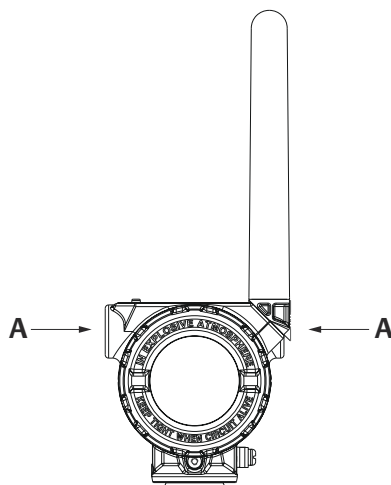

A. Conduit entry

3.2.4

Communication Device connections

The Black Power Module needs to be installed in the device for the Communication Device to interface with the Rosemount 648 Wireless. For HART® Wireless Transmitter communication via a Communication Device, a Rosemount 648 Wireless Device Dashboard (DD) is required. Rosemount 648 Wireless Transmitters equipped with Rosemount X-well Technology requires DD revision 648 Dev. 4 Rev. 1 or higher to view Rosemount X-well functionality. To obtain the latest DD, visit the Field Communicator System Software and Device Description site at: [Emerson.com/FieldCommunicator](https://www.emerson.com/en-us/field-communicator).

Refer to [Figure 3-3](#) for instructions on connecting the Communication Device to the Rosemount 648 Wireless Transmitter.

Figure 3-3: Connection

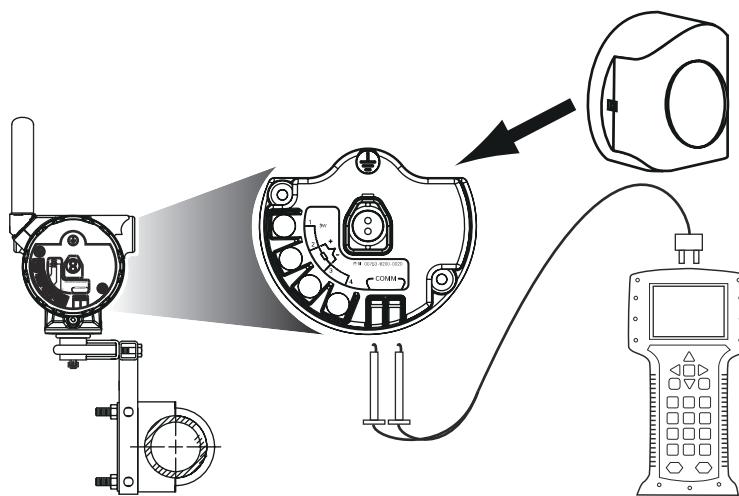

3.3 Physical installation

3.3.1 Transmitter installation

You can install the transmitter in one of two configurations:

Direct Mount The sensor is connected directly to the transmitter housing's conduit entry.

Remote Mount The sensor is mounted separately from the transmitter housing and then connected to the transmitter using conduit.

Select the installation sequence that corresponds to the mounting configuration.

3.3.2 Direct mount

Do not use direct mount installation when installing with a Swagelok® fitting.

Procedure

1. Install sensor according to standard installation practices using approved thread sealant on all connections.
2. Attach transmitter housing to the sensor using the threaded conduit entry.
3. Attach sensor wiring to the terminals as indicated on the wiring diagram.
4. Connect Black Power Module.

NOTICE

Wireless devices should be powered up in order of proximity from the Wireless Gateway, beginning with the closest device to the gateway. This will result in a simpler and faster network installation.

Figure 3-4: Installing Electronics Housing Cover

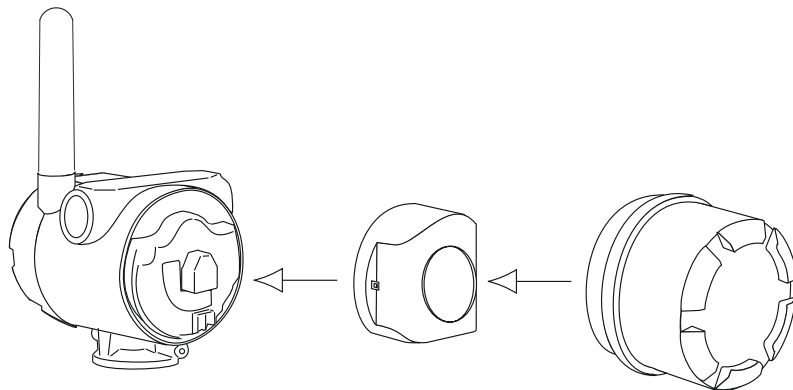

5. Close housing cover and tighten to safety specification.

NOTICE

Always ensure a proper seal by installing the electronics housing covers so metal touches metal, but do not overtighten.

6. Position antenna vertically, either straight up or straight down.

NOTICE

The antenna should be approximately 3 ft. (1 m) from any large structures or buildings. This will allow clear communication to other devices.

Figure 3-5: Possible Antenna Rotation

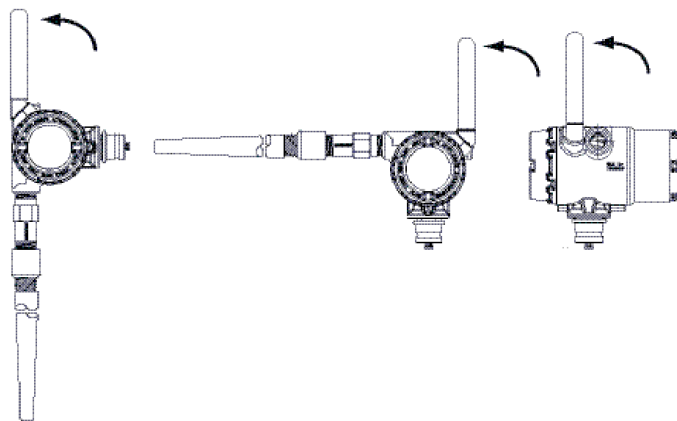

3.3.3 Remote mount

Procedure

1. Install sensor according to standard installation practices using an approved thread sealant on all connections.
2. Run wiring (and conduit, if necessary) from the sensor to the transmitter.
3. Pull wiring through the threaded conduit entry of the transmitter.
4. Attach sensor wiring to the terminals as indicated on the wiring diagram.
5. Connect Black Power Module.

NOTICE

Wireless devices should be powered up in order of proximity from the wireless gateway, beginning with the closest device to the Gateway. This will result in a simpler and faster network installation.

Figure 3-6: Installing electronics housing cover

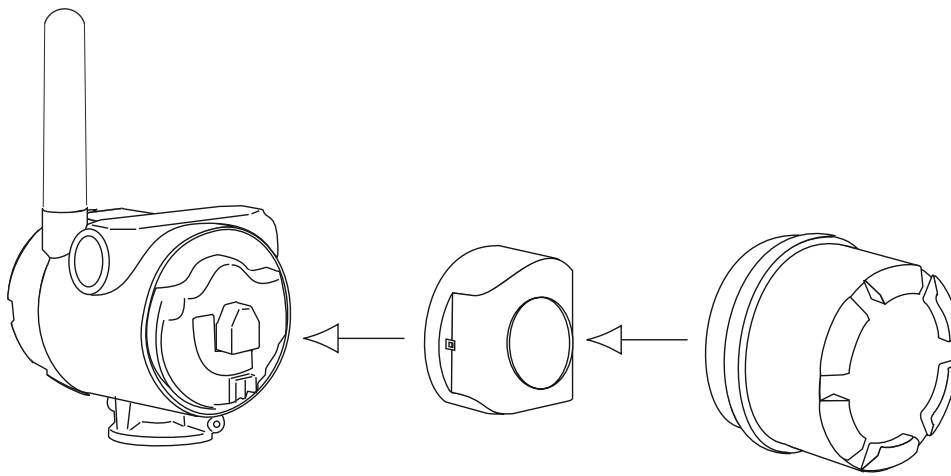

6. Close housing cover and tighten to safety specification.

NOTICE

Always ensure a proper seal by installing the electronics housing covers so metal touches metal, but do not over-tighten.

7. Position antenna vertically, either straight up or straight down.

NOTICE

The antenna should be approximately 3 ft. (1 m) from any large structures or buildings. This will allow clear communication to other devices.

Figure 3-7: Possible Antenna Rotation

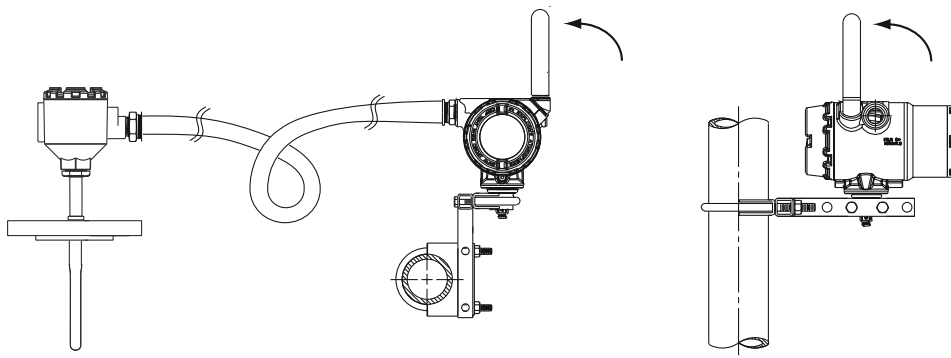

3.3.4 Install X-Well Technology

X-well Technology is only available in the 648 Wireless and 0085 Pipe Clamp Sensor factory assembled complete point solution.

X-well Technology will only work as specified with factory supplied and assembled pipe clamp sensor.

In general, pipe clamp sensor installation best practices shall be followed (see Rosemount 0085 Pipe Clamp Sensor [Reference Manual](#)) with Rosemount X-well Technology specific requirements noted below:

Procedure

1. Mount the transmitter directly on pipe clamp sensor.
2. Place transmitter head away from dynamic external temperature sources, such as a boiler.
3. Insulation ($\frac{1}{2}$ in. [13 mm] thick minimum) is required over the sensor clamp assembly and sensor extension up to transmitter head to prevent heat loss. Apply a minimum of 6 in. (152 mm) of insulation on each side of the pipe clamp sensor.

NOTICE

Take care to minimize air gaps between insulation and pipe.

See [Figure 3-8](#).

NOTICE

Do not apply insulation over transmitter head.

4. Although it will come factory configured as such, ensure that pipe clamp RTD sensor is assembled in 3-wire configuration.

Figure 3-8: Rosemount 648 Wireless with Rosemount X-well Technology Installation Drawing

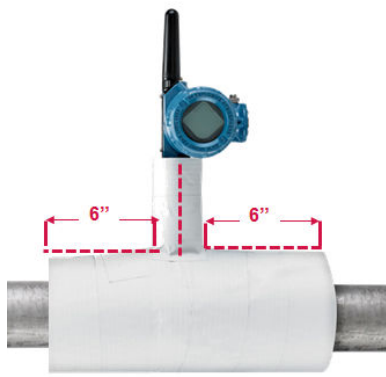

3.3.5 LCD display

Transmitters ordered with the optional LCD display will be shipped with the display installed. The LCD display can be rotated in 90 degree increments by squeezing the two tabs, pulling out, rotating and snapping back into place. If LCD display pins are inadvertently removed from the interface board, carefully reinsert the pins before snapping the LCD display back into place.

Procedure

1. Remove the LCD display cover.

⚠ WARNING

Do not remove the instrument covers in explosive environments when the circuit is live.

2. Put the 4-pin connector into the LCD display, rotate to the desired position and snap into place.
3. Replace the transmitter cover.

LCD display temperature limits:

- Operating: -4 to +175 °F (-20 to +80 °C)
- Storage: -40 to +185 °F (-40 to +85 °C)

Note

Only use Rosemount Wireless LCD Display part number: 00753-9004-0002.

Figure 3-9: Optional LCD Display

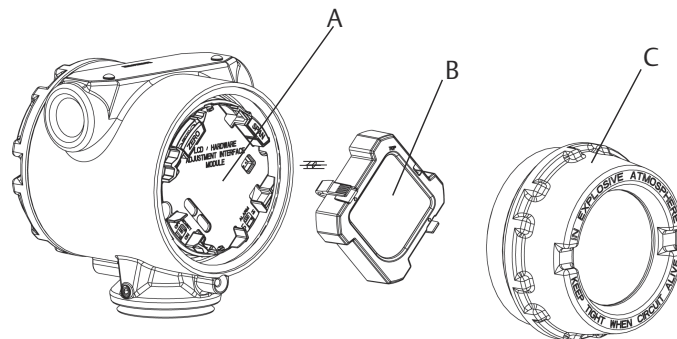

- A. LCD display pins
- B. LCD display
- C. LCD display cover

3.4 Ground the transmitter

The transmitter will operate with the housing either floating or grounded. However, the extra noise in floating systems affects many types of readout devices. If the signal appears noisy or erratic, grounding the transmitter at a single point may solve the problem.

⚠ WARNING

Ground the electronics enclosure in accordance with local and national installation codes.

This can be accomplished via the process connection, via the internal case grounding terminal, or via the external grounding terminal.

3.4.1 Thermocouple, mV, and RTD/Ohm inputs

Each process installation has different requirements for grounding. Use the grounding options recommended by the facility for the specific sensor type, or begin with grounding Option 1 (the most common).

Option 1

Procedure

1. Connect sensor wiring shield to the transmitter housing (only if the housing is grounded).
2. Ensure the transmitter housing is electrically isolated from the sensor wiring.

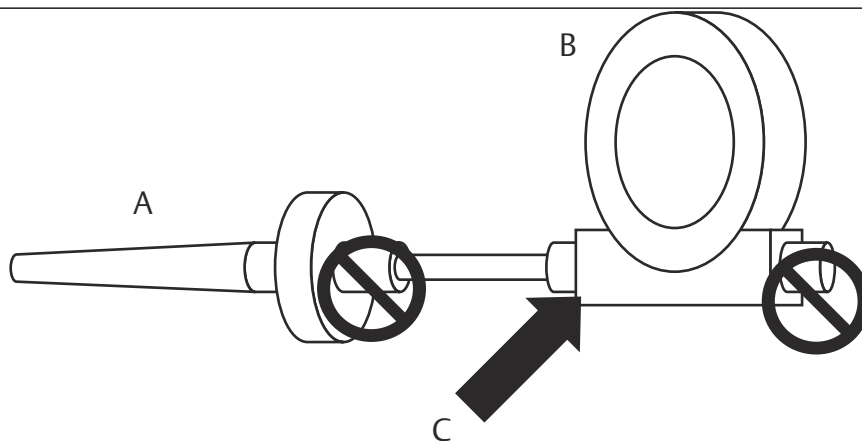

- A. Sensor wires
- B. Transmitter
- C. Shield ground point

Option 2

Procedure

1. Ground sensor wiring shield at the sensor.
2. Ensure the sensor wiring and shield is electrically isolated from the transmitter housing.

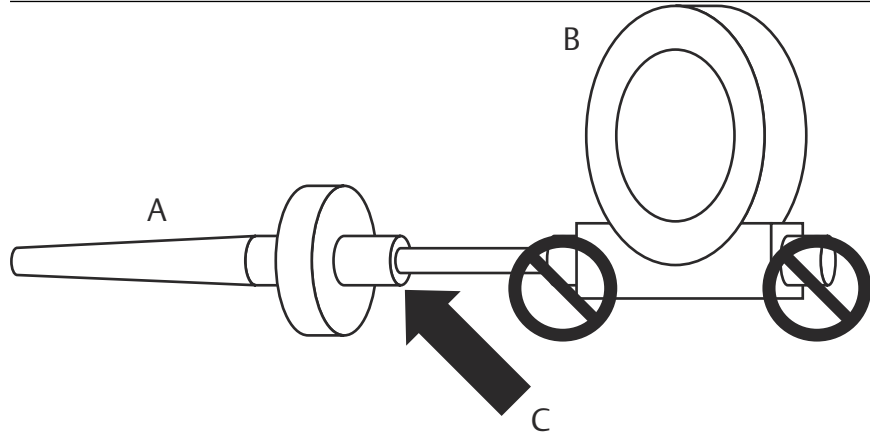

- A. Sensor wires
- B. Transmitter
- C. Shield ground point

NOTICE

Always use facility recommended wiring practices.

4 Commissioning

4.1 Overview

The information in this section contains techniques to properly commission the device. A [Rosemount 648 Wireless Temperature Transmitter Quick Start Guide](#) is shipped with every transmitter to describe basic installation and startup procedures.

4.2 Verify operation

The transmitter can be commissioned before or after installation. It may be useful to commission it on the bench, before installation, to ensure proper operation and to become familiar with its functionality. When applicable, make sure the instruments are installed in accordance with intrinsically safe or non-incendive field wiring practices. The device will be powered whenever the power module is installed. To avoid depleting the power module, make sure it is removed when the device is not in use.

Operation can be verified in four locations: at the device via the LCD display, using a Communication Device, the Wireless Gateway's integrated web interface, or using AMS Suite Wireless Communicator or AMS Device Manager.

4.2.1 LCD display

During normal operation, the LCD display will display the PV value at the wireless transmit rate up to as fast as one minute intervals. Refer to [LCD display screen messages](#) for error codes and other LCD display messages. Press the **Diagnostic** button to display the **Tag**, **Device ID**, **Network ID**, **Network Join Status** and **Device Status** screens. For **Device Status** screens, see [Start-up screen sequence](#).

Figure 4-1: Diagnostic Screen Sequence

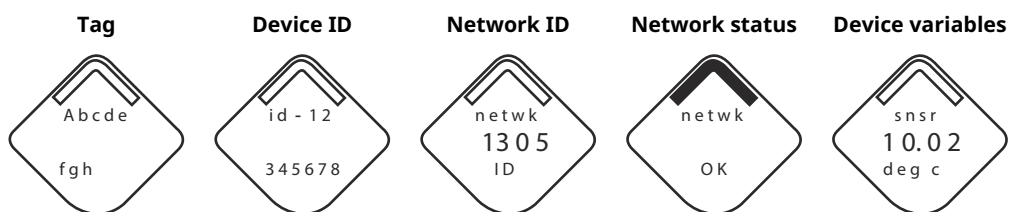
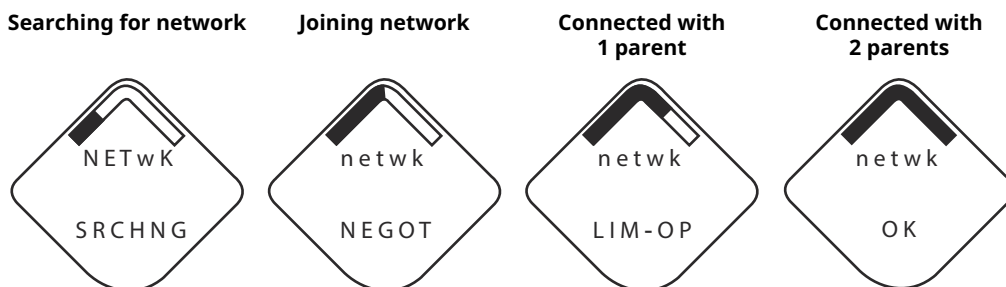

Figure 4-2: Network Status Screens



4.2.2 Communication Device

For HART Wireless transmitter communication via a Communication Device, a Rosemount 648 Wireless Device descriptor (DD) is required. Rosemount 648 Wireless Transmitter equipped with Rosemount X-well Technology requires DD revision 648 Dev. 4 Rev. 1 or higher to view Rosemount X-well functionality. To obtain the latest DD, visit [Software Downloads & Drivers](#).

The communication status may be verified in the wireless device using the following Fast Key sequence.

Function	Fast Key sequence	Menu items
Communication	3, 4	<ul style="list-style-type: none"> • Comm • Join Mode • Neighbor Count • Advertisement Count • Join Attempts

4.2.3 Wireless Gateway

If the Rosemount 648 Wireless was configured with the Network ID and Join Key and sufficient time for network polling has passed, the transmitter will be connected to the network. To verify device operation and connectivity using the Wireless Gateway's web based user interface, navigate to the **Devices** page. This page will also display the transmitter's **tag**, **PV**, **SV**, **TV**, **QV**, and **Last Update time**. Refer to Emerson Wireless Gateway [Manual Supplement](#) for terms, user fields, and parameters used in the Wireless Gateway web based user interface.

Note

The time to join the new device(s) to the network is dependent upon the number of devices being joined and the number of devices in the current network. For one device joining an existing network with multiple devices, it may take up to five minutes. It may take up to 60 minutes for multiple new devices to join the existing network.

Figure 4-3: Wireless Gateway Devices Page

The screenshot displays the 'Wireless Gateway' interface. At the top, there is a navigation bar with 'Home', 'Devices', and 'System Settings'. Below this, there are four summary cards: 'All Devices' with a count of 3, 'Live' with a count of 3, 'Unreachable' with a count of 0, and 'Power Module Low' with a count of 0. A table titled 'Devices' shows a list of three devices. The table has columns for Name, PV, SV, TV, QV, and Last Update. The first device is 248X-100584 with PV 0.37 DegC, SV NaN, TV 22.25 DegC, QV 3.64 V, and Last Update 09/23/15 14:57:23. The second device is 648X-201608 with PV 913.04 DegC, SV NaN, TV 23.5 DegC, QV 7.2 V, and Last Update 09/23/15 14:57:13. The third device is 848TX-302120 with PV 0.92 mV, SV 23.23 DegC, TV 23.23 DegC, QV 23.25 DegC, and Last Update 09/23/15 14:57:13. At the bottom, there is a footer with 'EMERSON', 'HOME', 'DEVICES', 'SYSTEM SETTINGS', 'ABOUT', 'HELP', 'Feedback', 'Terms Of Use', and '© 2015 Emerson Electric Co. All Rights Reserved. Consider It Solved.'

4.2.4 AMS Wireless Configurator

For HART Wireless transmitter communication via AMS Wireless Configurator, a Rosemount 648 Wireless Device descriptor (DD) is required. Rosemount 648 Wireless Transmitters equipped with Rosemount X-well technology requires DD revision 648 Dev. 4 Rev. 1 or higher to view Rosemount X-well functionality. To obtain the latest DD, visit the [Software Downloads & Drivers](#).

Figure 4-4: AMS Wireless Configurator Explorer Window

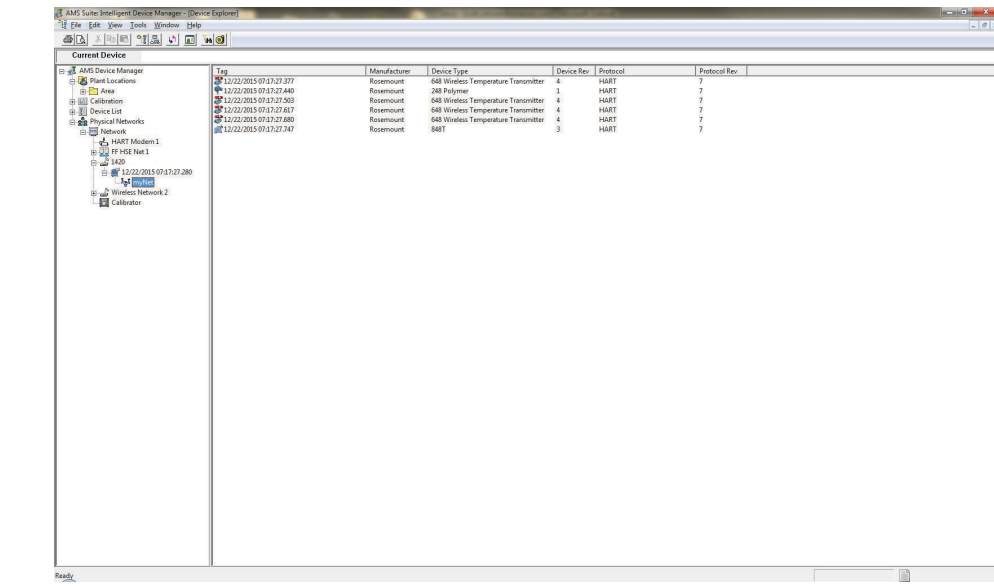





5 Operation and maintenance

5.1 LCD display screen messages

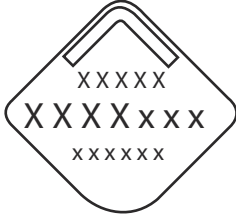
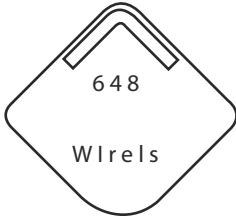
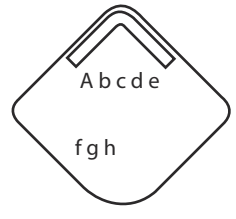
5.1.1 Start-up screen sequence

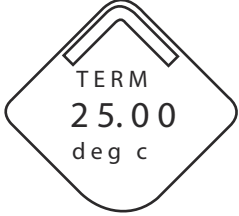

The following screens will display when the power module is first connected to the transmitter.

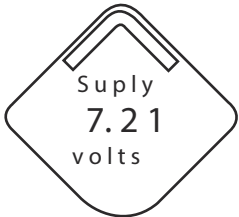
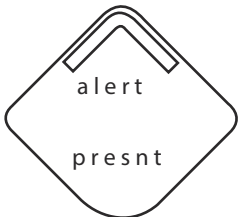
	<p>All Segments On: used to visually determine if there are any bad segments on the LCD display</p>
	<p>Device Identification: used to determine Device Type</p>
	<p>Device Information - Tag: user entered tag which is eight characters long - will not display if all characters are blank</p>
	<p>PV Screen: process temperature, ohms or mV value depending on how the device is configured</p>

 <p>TERM 25.00 deg c</p>	<p>SV Screen: terminal temperature value</p>
 <p>DEV 25.25 deg c</p>	<p>TV Screen: feature board temperature value</p>
 <p>Suply 7.21 volts</p>	<p>QV Screen: voltage reading at the power module terminals</p>
 <p>alert presnt</p>	<p>Alert Screen: at least one alert is present - this screen will not display if no alerts are present</p>

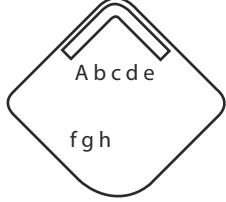
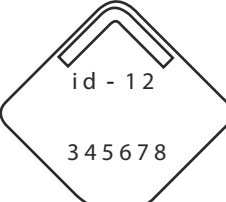

5.1.2 Diagnostic button screen sequence

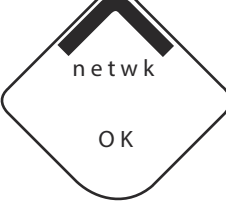
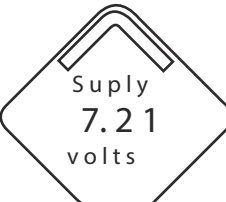
The following five screens will display when the device is operating properly and the **Diagnostic** Button has been pressed.

	<p>Device Information - Tag: user entered tag which is 8 characters long - will not display if all characters are blank</p>
	<p>Device Identification: used to determine Device ID</p>
	<p>Diagnostic Button Screen 3: assuming the device has the correct join key, this ID tells the user what network the device can connect with</p>
	<p>Diagnostic Button Screen 4.11: the device has joined a network and has been fully configured and has multiple parents</p>
	<p>Diagnostic Button Screen 5: voltage reading at the power module terminals</p>

5.1.3 Network diagnostic status screens

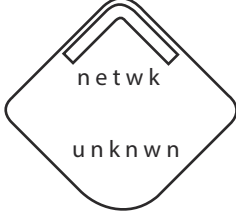
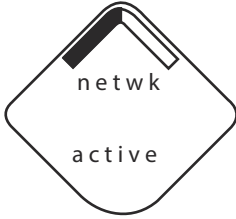
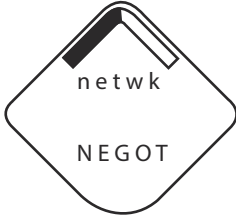

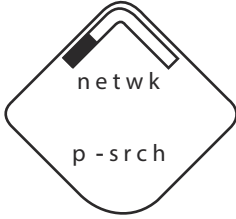
These screens display the network status of the device. Only one will be shown during the startup sequence or diagnostic sequence.

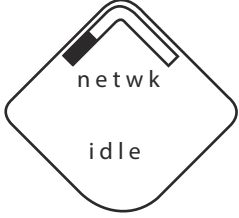
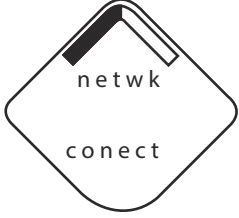
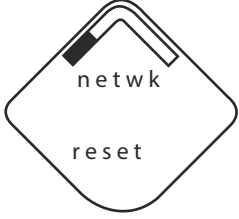
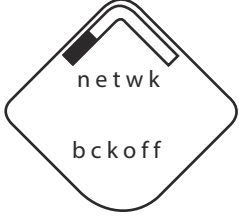
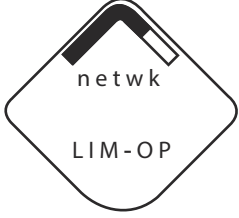
 <p>netwk unkwn</p>	<p>Diagnostic Button Screen 4.1: the device has yet to retrieve the information from the Smart Wireless Gateway and is still in the process of being activated</p>
 <p>netwk active</p>	<p>Diagnostic Button Screen 4.2: the device has received the ACTIVATE command from the Smart Wireless Gateway, but is in the process of being configured to the wireless network</p>
 <p>netwk NEGOT</p>	<p>Diagnostic Button Screen 4.3: the device has sent JOIN request and is waiting for the ACTIVATE command</p>
 <p>NETwK SRCHNG</p>	<p>Diagnostic Button Screen 4.4: the device is in active search</p>
 <p>netwk p-srch</p>	<p>Diagnostic Button Screen 4.5: the device is in passive search</p>

	<p>Diagnostic Button Screen 4.6: the device couldn't find the network and is in deep sleep mode to preserve power module life</p>
	<p>Diagnostic Button Screen 4.7: the device synchronized to a network</p>
	<p>Diagnostic Button Screen 4.8: the device will reset</p>
	<p>Diagnostic Button Screen 4.9: the device couldn't join because of dropped packets and will reset</p>
	<p>Diagnostic Button Screen 4.10: the device has joined a network and has been fully configured but has only one parent device</p>

5.1.4 Device diagnostic screens

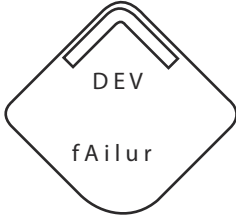
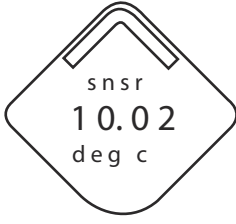
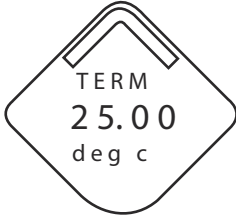
The following screens will show the device diagnostics depending on the state of the device.

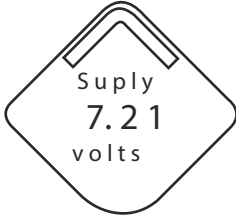
 A diamond-shaped icon with a stylized device symbol at the top. The text inside the diamond reads "DEV" at the top and "fAilur" at the bottom.	<p>Device Information - Status: there is a critical error which may prevent the device from operating correctly. Check additional status screens for more information.</p>
 A diamond-shaped icon with a stylized device symbol at the top. The text inside the diamond reads "snsr" at the top, "10.02" in the middle, and "deg c" at the bottom.	<p>PV Screen: process temperature, ohms or mV value depending on how the device is configured</p>
 A diamond-shaped icon with a stylized device symbol at the top. The text inside the diamond reads "TERM" at the top, "25.00" in the middle, and "deg c" at the bottom.	<p>SV Screen: terminal temperature value</p>
 A diamond-shaped icon with a stylized device symbol at the top. The text inside the diamond reads "DEV" at the top, "25.25" in the middle, and "deg c" at the bottom.	<p>TV Screen: feature board temperature value</p>
 A diamond-shaped icon with a stylized device symbol at the top. The text inside the diamond reads "Suply" at the top, "7.21" in the middle, and "volts" at the bottom.	<p>QV Screen: voltage reading at the power module terminals</p>

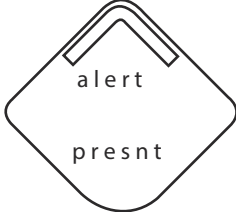
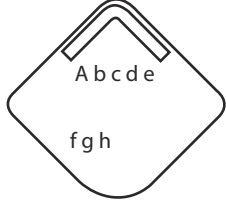
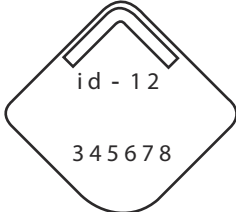
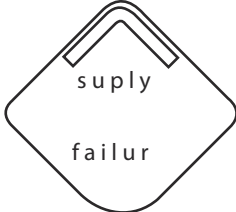
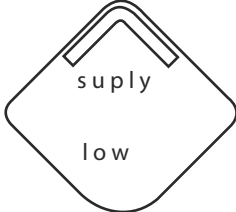
	<p>Alert Screen: at least one alert is present - this screen will not display if no alerts are present</p>
	<p>Diagnostic Button Screen 1 - Tag: user entered tag which is 8 characters long - will not display if all characters are blank</p>
	<p>Diagnostic Button Screen 2: the device's identifier that is used to make up the HART long address - the Smart Wireless Gateway may use this to help identify devices if no unique user tag is available</p>
	<p>Diagnostic Button Screen 7.1: the terminal voltage has dropped below level of operating limit. Replace the Power Module (Part Number: 00753-9220-0001)</p>
	<p>Diagnostic Button Screen 7.2: the terminal voltage is below the recommended operating range - if this is a self-powered device, the power module should be replaced - for line powered devices, the supply voltage should be increased</p>

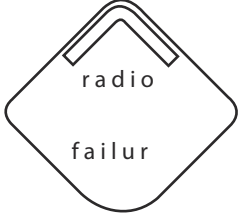
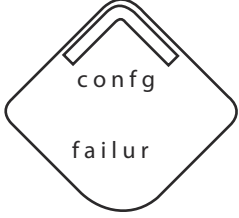
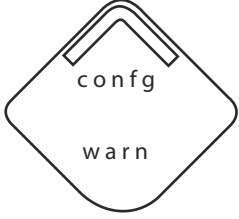
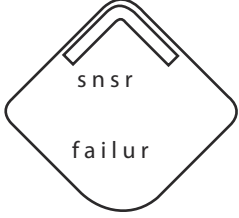
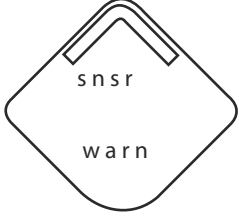
	<p>Diagnostic Button Screen 8: the device cannot retrieve information from the radio in the device - the device may still be operational and publishing HART data</p>
	<p>Diagnostic Button Screen 9.1: configuration of the transmitter is invalid such that critical operation of the device may be affected - check the extended configuration status to identify which configuration item(s) need to be corrected</p>
	<p>Diagnostic Button Screen 9.2: configuration of the transmitter is invalid such that non-critical operation of the device may be affected - check the extended configuration status to identify which configuration item(s) need to be corrected</p>
	<p>Diagnostic Button Screen 10.1: a sensor attached to the transmitter has failed, and valid readings from that sensor are no longer possible - check the sensor and sensor wiring connections - check additional status for more detailed information of the failure source</p>
	<p>Diagnostic Button Screen 10.2: a sensor attached to the transmitter is degraded, readings from that sensor may not be within accuracy specifications - check the process, and sensor wiring connections - check additional status for more detailed information of the warning source</p>

Note

Use the Rosemount Wireless LCD display part number: 00753-9004-0002.

5.2 Power module replacement

Expected black power module life is 10 years at reference conditions.⁽²⁾

The following must be considered before replacing the power module:

5.2.1 Replace the power module

Procedure

1. Remove the cover and module.
2. Replace the module (part number 701PBKKF) and cover.
3. Tighten to specification and verify operation.

5.2.2 Handling considerations

The black power module with the wireless unit contains two "C" size primary lithium-thionyl chloride battery (Black Power Module, model number 701PBKKF).

Each battery contains approximately 5.0 grams of lithium. Under normal conditions, the battery materials are self-contained and are not reactive as long as the batteries and the pack integrity are maintained.

NOTICE

Take care to prevent thermal, electrical, or mechanical damage.
Protect contacts to prevent premature discharge.

Black Power Module should be stored in a clean and dry area. For maximum Black Power Module life, storage temperature should not exceed 86 °F (30 °C).

NOTICE

Continuous exposure to ambient temperature limits of < -40 °F (-40° C) or > +185 °F (+85 °C) may reduce specified life by less than 20 percent.

NOTICE

The black power module may be damaged if dropped from heights in excess of 20 ft. (6.1 m).

Use caution when handling the black power module.

⚠ WARNING

Battery hazards remain when cells are discharged.

⁽²⁾ Reference conditions are +70 °F (21° C), transmit rate of once per minute, and routing data for three additional network devices.

5.2.3 Environmental considerations

NOTICE

As with any battery, consult local environmental rules and regulations for proper management of spent batteries. If no specific requirements exist, Emerson encourages recycling through a qualified recycler. For battery specific information, consult the Safety Data Sheet.

5.2.4 Shipping considerations

Emerson shipped the transmitter without the black power module installed.

NOTICE

Remove the black power module prior to shipping the transmitter.

6 Troubleshooting

6.1 Overview

The following sections provide summarized maintenance and troubleshooting suggestions for the most common operating problems. If you suspect malfunction despite the absence of any diagnostic messages on the Communication Device display, follow the procedures described here to verify transmitter hardware and process connections are in good working order. Always deal with the most likely checkpoints first.

6.2 Device status

6.2.1 Electronics failure

Description

An electronics error that could impact the device measurement reading has occurred.

Recommended actions

1. Reset the device.
2. Reconfirm all configuration items in the device.
3. If the condition persists, replace the electronics.

6.2.2 Terminal block failure

Description

A critical failure has occurred in the transmitter's terminal block.

Recommended actions

1. Reset the device.
2. Replace the terminal block.

6.2.3 Sensor failure

Description

The device has detected an open, short, or too much resistance for this sensor.

Recommended actions

1. Verify the sensor connection and wiring. Refer to the wiring diagrams found on the terminal compartment to ensure proper wiring.
2. Verify the integrity of the sensor and sensor lead wires. If the sensor is faulty, repair or replace the sensor.
3. Reconfirm sensor configuration.
4. Replace the sensor.
5. If problem persists, replace the electronics.

6.2.4 Radio failure

Description

The wireless radio has detected a failure or stopped communicating.

Recommended actions

1. Reset the device.
2. If the condition persists, replace the electronics.

6.2.5 Supply voltage failure

Description

The supply voltage is too low for the device to broadcast updates.

Recommended actions

Replace the power module.

6.2.6 Electronics warning

Description

The device has detected an electronics error that does not currently impact the device measurement reading.

Recommended actions

1. Reset the device.
2. Reconfirm all configuration items in the device.
3. If the condition persists, replace the electronics.

6.2.7 Sensor has exceeded limits

Description

The sensor has exceeded the maximum measurement range.

Recommended actions

1. Check process for possible saturation condition.
2. Verify the appropriate sensor was chosen for the application.
3. Reconfirm sensor configuration.
4. Reset the device.
5. Replace the sensor.

6.2.8 Electronics temperatures has exceeded limits

Description

The electronics temperature has exceeded the transmitter's maximum range.

Recommended actions

1. Verify environmental temperature is within the transmitter's range.

2. Remote mount the transmitter away from process and environmental conditions.
3. Reset the device.
4. If the condition persists, replace the electronics.

6.2.9 Terminal temperature has exceeded limits

Description

The terminal temperature has exceed the transmitter's maximum range.

Recommended actions

1. Verify environmental temperature is within the transmitter's range.
2. Remote mount the transmitter away from process and environmental conditions.
3. Reset the device.
4. If the condition persists, replace the electronics.

6.2.10 Supply voltage low

Description

The supply voltage is low and may soon affect broadcast updates.

Recommended actions

Replace the power module.

6.2.11 Database memory warning

Description

The device has failed to write to the database memory. Any data written during this time may have been lost.

Recommended actions

1. Reset the device.
2. Reconfirm all configuration items in the device.
3. If logging dynamic data not needed, this advisory can be safely ignored.
4. If the condition persists, replace the electronics.

6.2.12 Invalid Configuration

Description

The device has detected a configuration error based on a change to the device.

Recommended actions

1. Select details for more information.
2. Correct the parameter that has a configuration error.
3. Reset the device.
4. If the condition persists, replace the electronics.

6.2.13 Hi Hi alarm

Description

The primary variable has surpassed the user defined limit.

Recommended actions

1. Verify the process variable is within user specified limits.
2. Reconfirm the user defined alarm limit.
3. If not needed, disable this alert.

6.2.14 Hi alarm

Description

The primary variable has surpassed the user defined limit.

Recommended actions

1. Verify the process variable is within user specified limits.
2. Reconfirm the user defined alarm limit.
3. If not needed, disable this alert.

6.2.15 Lo alarm

Description

The primary variable has surpassed the user defined limit.

Recommended actions

1. Verify the process variable is within user specified limits.
2. Reconfirm the user defined alarm limit.
3. If not needed, disable this alert.

6.2.16 Lo Lo alarm

Description

The primary variable has surpassed the user defined limit

Recommended actions

1. Verify the process variable is within user specified limits.
2. Reconfirm the user defined alarm limit.
3. If not needed, disable this alert.

6.2.17 Button stuck

Description

A button on the Electronic Board is detected as stuck in the active position.

Recommended actions

1. Check the buttons for obstructions.

2. Reset the device.
3. If conditions persist, replace the electronics.

6.2.18 Simulation active

Description

The device is in simulation mode and may not be reporting actual information.

Recommended actions

1. Verify simulation is no longer required.
2. Disable **Simulation** mode in **Service Tools**.
3. Reset the device.

6.3 Transmitter output

6.3.1 High output temperature detected

Potential cause

Sensor input failure or connection

Recommended actions

1. Connect a Communication Device and enter the transmitter test mode to isolate a sensor failure.
2. Check for a sensor open or short circuit.
3. Check the process variable to see if it is out of range.

Potential cause

Electronics module

Recommended actions

1. Connect a Communication Device and enter the **transmitter status** mode to isolate module failure.
2. Connect a Communication Device and check the sensor limits to ensure calibration adjustments are within the sensor range.

6.3.2 Digital temperature output is erratic

Potential cause

Wiring

Recommended actions

Check sensor wiring integrity at all junctions to ensure proper connections.

Potential cause

Electronics module

Recommended actions

Connect a Communication Device and enter the **transmitter test** mode to isolate module failure.

6.3.3 Low output or no output

Potential cause

Sensor element

Recommended actions

1. Connect a Communication Device and enter the **transmitter test** mode to isolate a sensor failure.
2. Check the process variable to see if it is out of range.

6.4 LCD display

6.4.1 LCD display not operating

Potential cause

Electronic module

Recommended actions

Ensure the LCD display is enabled.

Potential cause

Connector

Recommended actions

Ensure the LCD display pins are not bent.

Potential cause

LCD display

Recommended actions

Ensure the LCD display is properly seated with the tabs snapped in place and fully engaged.

6.5 Wireless network

6.5.1 Device not joining the network

Recommended actions

1. Verify network ID and join key.
2. Verify network is in **active network advertise**.
3. Wait longer (30 minutes).
4. Check power module.
5. Verify device is within range of at least one other device.

6. Power cycle device to try again.
7. Verify device is configured to join. Ensure the **Join Mode** is configured to **Join on Powerup or Reset**.

6.5.2 Short battery life

Recommended actions

1. Check that **Power Always On** mode is off.
2. Verify device is not installed in extreme temperatures.
3. Verify device is not a network pinch point.
4. Check for excessive network rejoins due to poor connectivity.

6.5.3 Limited bandwidth error

Recommended actions

1. Reduce the update rate on transmitter.
2. Increase communication paths by adding more wireless points.
3. Check that device has been on line for at least an hour.
4. Check that device is not routing through a "limited" routing node.
5. Create a new network with an additional Wireless Gateway.

A Reference data

A.1 Ordering information, specifications, and drawings

To view current Rosemount 648 Wireless Temperature Transmitter ordering information, specifications, and drawings, follow these steps:

Procedure

1. Go to [Rosemount 648 Wireless Temperature Transmitter](#).
2. Scroll as needed to the green menu bar and click **Documents & Drawings**.
3. Click **Data Sheets & Bulletins**.
4. Select the appropriate Product Data Sheet.

A.2 Product certifications

To view current product certifications, follow these steps:

Procedure

1. Go to [Rosemount 648 Wireless Temperature Transmitter](#).
2. Scroll as needed to the green menu bar and click **Documents & Drawings**.
3. Click **Manuals & Guides**.
4. Select the appropriate Quick Start Guide.

B Mapping for Non device descriptor (DD) based integration with host systems

B.1 Alert message mapping

This outlines the most important alerts in the HART command **48 Additional Status** Field for the Rosemount 648 Wireless Temperature Transmitter. The information in this section can be used by DeltaV™ for alert monitoring, and in the Emerson 1410S Wireless Gateway for Additional Status mapping in Modbus®, OPC UA®, etc.

A complete list of additional status bits is available in the [Emerson Wireless 1410S Gateway and 781S Smart Antenna Reference Manual](#).

[Table B-1](#) and [Table B-2](#) show a list of the most important alert messages that may display in the AMS Wireless Configurator and Communication Device together with the location of the Alert in the HART command **48 Additional Status** field. For recommended actions refer to [Troubleshooting](#).

To view **Active Alerts**, from the **Home** screen, go to **Service Tools** → **Active Alerts**.

Table B-1: Failure Alerts (F:)

Message	Additional status ⁽¹⁾	Description
Electronics Failure	Byte 0 :: Bit 0 Byte 0 :: Bit 1 Byte 0 :: Bit 3 Byte 0 :: Bit 6 Byte 0 :: Bit 7 Byte 8 :: Bit 1 Byte 8 :: Bit 2 Byte 8 :: Bit 6	An electronics error that could impact the device measurement reading has occurred.
Terminal Block Failure	Byte 3 :: Bit 2 Byte 3 :: Bit 3 Byte 3 :: Bit 6	A critical failure has occurred in the transmitter's terminal block.
Sensor Failure	Byte 3 :: Bit 7	The device has detected an open, short, or too much resistance for this sensor.
Radio Failure	Byte 1 :: Bit 1 Byte 1 :: Bit 7	The wireless radio has detected a failure or stopped communicating
Supply Voltage Failure	Byte 1 :: Bit 4 Byte 5 :: Bit 2	The supply voltage is too low for the device to broadcast.
Electronics Warning	Byte 0 :: Bit 4 Byte 0 :: Bit 5	The device has detected an electronics error that does not currently impact the device measurement reading.
Sensor has Exceeded Limits	Byte 3 :: Bit 4 Byte 3 :: Bit 5	The sensor has exceeded the maximum measurement range.

Table B-1: Failure Alerts (F:) (continued)

Message	Additional status ⁽¹⁾	Description
Terminal Temperature has Exceeded Limits	Byte 1 :: Bit 2 Byte 1 :: Bit 3 Byte 8 :: Bit 5	The terminal temperature has exceeded the transmitter's maximum range.
Electronics Temperature has Exceeded Limits	Byte 3 :: Bit 0 Byte 3 :: Bit 1	The electronics temperature has exceeded the transmitter's maximum range.
Supply Voltage Low	Byte 1 :: Bit 6 Byte 8 :: Bit 4	The supply voltage is low and may soon affect broadcast updates.

(1) Location of the Alert in the HART command **48 Status** field.

Table B-2: Advisory Alerts (A:)

Message	Additional status ⁽¹⁾	Description
Database Memory Warning	Byte 0 :: Bit 2	The device has failed to write to the database memory. Any data written during this time may have been lost.
Invalid Configuration	Byte 2 :: Bit 6	The device has detected a configuration error based on a change to the device.
HI HI Alarm	Byte 5 :: Bit 4	The primary variable has surpassed the user defined limit.
HI Alarm	Byte 5 :: Bit 5	The primary variable has surpassed the user defined limit.
LO Alarm	Byte 5 :: Bit 6	The primary variable has surpassed the user defined limit.
LO LO Alarm	Byte 5 :: Bit 7	The primary variable has surpassed the user defined limit.
Button Stuck	Byte 1 :: Bit 5	A button on the Electronics Board is detected as stuck in the active position.
Simulation Active	Byte 8 :: Bit 0	The device is in simulation mode and may not be reporting actual information.

(1) Location of the Alert in the HART command **48 Status** field.

B.2 Mapping device variable index numbers

To integrate a device into the host system, it may be necessary to know what each device variable represents and what index number it has been assigned to. The variable index

number is an arbitrary number used to uniquely identify each variable supported in the field device.

[Device variable index](#) and [Variable mapping](#) display the device variable and variable mapping indexes for the transmitter.

Device variable index

0	Supply Voltage
1	Electronics Temperature
2	Process Temperature
3	Terminal Temperature (for CJC)
244	Percent of Range

Variable mapping

PV	2 - Process Temperature
SV	3 - Terminal Temperature
TV	1 - Electronics Temperature
QV	0 - Supply Voltage

For more information: [Emerson.com/global](https://emerson.com/global)

©2024 Emerson. All rights reserved.

Emerson Terms and Conditions of Sale are available upon request. The Emerson logo is a trademark and service mark of Emerson Electric Co. Rosemount is a mark of one of the Emerson family of companies. All other marks are the property of their respective owners.

ROSEMOUNT™

