

2000 and 2500 Series Emergency Pressure Relief Vents (ATEX Approved)

Table of Contents

Introduction.....	1
Specifications	2
Product Identification and Marking	2
Principle of Operation	4
Installation	5
Maintenance.....	6

WARNING

Failure to follow these instructions or to properly install and maintain this equipment could result in an explosion, fire and/or chemical contamination causing property damage and personal injury or death.

Enardo emergency pressure relief vent must be installed, operated and maintained in accordance with federal, state and local codes, rules and regulations, and Emerson Process Management Regulator Technologies Tulsa, LLC (Emerson) instructions .

Failure to correct trouble could result in a hazardous condition. Call a qualified service person to service the unit. Installation, operation and maintenance procedures performed by unqualified person may result in improper adjustment and unsafe operation. Either condition may result in equipment damage or personal injury. Only a qualified person shall install or service the emergency pressure relief vent.

Introduction

Scope of the Manual

This Instruction Manual provides instructions for installation and maintenance for the 2000 and 2500 Series emergency pressure relief vents (EPRVs).

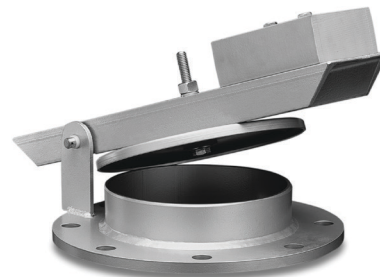

P1888

Figure 1. 2000 Series Emergency Pressure Relief Vent

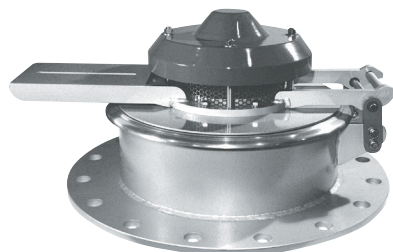

P1890

Figure 2. 2500 Series Emergency Pressure Relief Vent with Vacuum



Figure 3. 2000 Series with Smart Wireless Monitoring

Product Description

Emergency pressure relief vents are designed to provide an emergency pressure relief opening for storage tanks when exposed to overpressures that are not handled by standard tank vents.

2000 Series emergency pressure relief vent (EPRV) provides pressure relief only. 2500 Series emergency pressure relief vent with vacuum (EPRV-V) provides pressure and vacuum relief.

North America Only

2000 and 2500 Series

Specifications

The Specifications section lists the specifications for the 2000 and 2500 Series. Specification is stamped on the nameplate attached to the emergency relief vent. Refer to Product Identification and Marking section for the nameplate details.

<p>Connection Sizes Available See Table 1</p> <p>Pressure Ranges⁽¹⁾⁽²⁾</p> <p>2000 Series: 2.0 to 32.0 oz./sq. in. (0.5 oz./sq. in. increments) 3.5 to 55.0 in. w.c. (1.0 in. w.c. increments) 8.6 to 138 mbar (2.2 mbar increments)</p> <p>2500 Series: 4.0. to 16.0 oz./sq. in. (0.5 oz./sq. in. increments) 7.0 to 27.0 in. w.c. (0.5 in. w.c. increments) 17.4 to 67.2 mbar (2.2 mbar increments)</p> <p>Vacuum Pressure Ranges⁽¹⁾ (2500 Series) 0.5, 0.75, 1 and 2 oz./sq. in.</p>	<p>Construction Materials</p> <p>2000 Series <i>Base and Arm:</i> Carbon Steel, 304 Stainless steel and 316 Stainless steel <i>Disk and Seal Support:</i> Aluminum, 304 Stainless steel and 316 Stainless steel <i>Seal:</i> Buna-N, FEP Teflon® and Viton®</p> <p>2500 Series <i>Base, Arm and Hood:</i> Carbon steel, 304 Stainless steel and 316 Stainless steel <i>Disk and Seal Support:</i> Aluminum and 316 Stainless steel <i>Seal:</i> FEP Teflon®, Viton® and Buna-N <i>Vacuum Spring:</i> 302 Stainless steel <i>Vacuum Pallet and Vacuum Seat:</i> Polyphenylene Sulfide and 316 Stainless steel</p> <p>Certification EN IEC 60079-0:2018 EN IEC 60079-11:2012 EN ISO 80079-36:2016 EN ISO 80079-37:2016</p>
----------------------------------------------------------------------------------------------------------------------------------------------------------------------------------------------------------------------------------------------------------------------------------------------------------------------------------------------------------------------------------------------------------------------------------------------------------------------------------------------------------------------------------------------------------------------------------------------------------	------------------------------------------------------------------------------------------------------------------------------------------------------------------------------------------------------------------------------------------------------------------------------------------------------------------------------------------------------------------------------------------------------------------------------------------------------------------------------------------------------------------------------------------------------------------------------------------------------------------------------------------------------------------------------------------------------------------------------------------------------------------------------------------------------

1. The pressure limits in this Instruction Manual and any applicable standard or code limitation should not be exceeded.

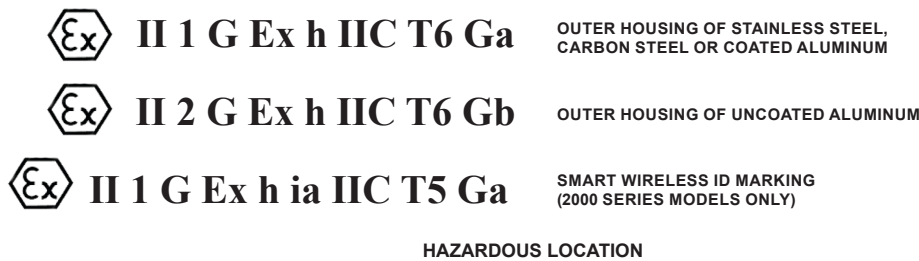

Figure 4. Product Identification and Marking

Table 1. Connection sizes and Model Number

SERIES	MODEL	CONNECTION SIZE	
		ANSI	API
2000 Series Emergency Pressure Relief - For Pressure Relief Only	2004	4 in.	----
	2008	8 in.	8 in.
	2012	12 in.	----
	2016	16 in.	----
	2018	18 in.	----
	2020	20 in.	20 in.
	2024	24 in.	24 in.
2500 Series Emergency Pressure Relief Vent with Vacuum - For Pressure and Vacuum Relief	2516	16 in.	----
	2520	20 in.	20 in.
	2524	24 in.	24 in.

Teflon® and Viton® are marks owned by E. I. du Pont de Nemours and Company.

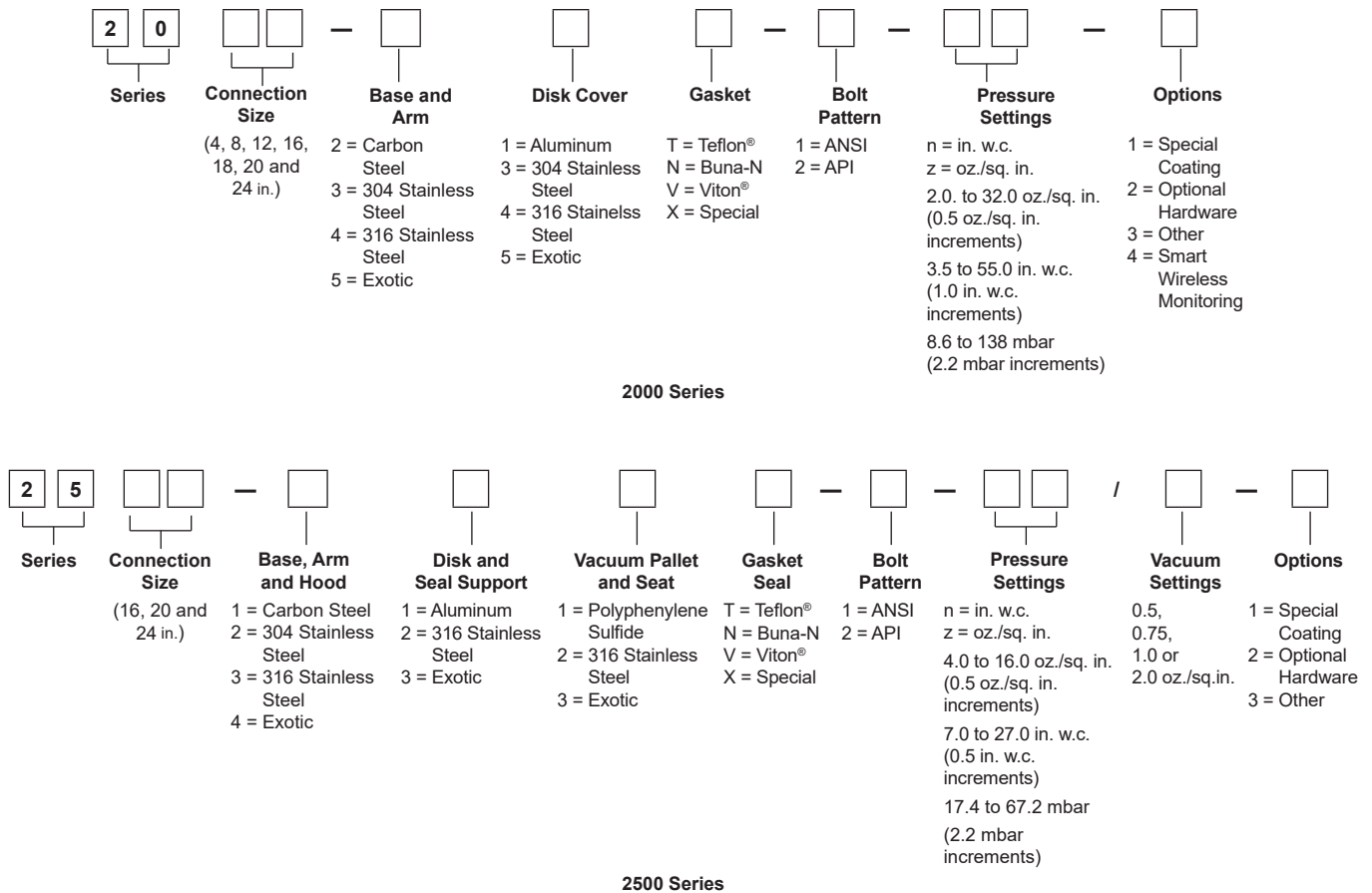

Figure 5. Emergency Pressure Relief Vent Model Number

Properly-sized 2000 and 2500 Series meet the API standard 2000 for emergency venting due to fire exposure. 2500 Series handles high capacity vacuum flow for emergency pump-out of product. These vents provide quick easy access for tank inspection and maintenance.

Remote Monitoring Option

The Smart Wireless monitoring option is available with the Enardo 2000 Series. It allows the detection of the Open or Closed position of the emergency vent from a remote site. Under normal conditions, the emergency vent should be Closed. An Open indication can alert personnel that there is a potential safety or emissions issue that should be further investigated.

Product Identification and Marking

Hazardous Locations

Enardo Emergency Pressure Relief Vents are available with outer housings of carbon steel, stainless steel or aluminum as indicated in Figure 4.

Nameplate

A nameplate is attached to the vent and contains the following information:

- **Model Number** – Ex. 2024-24T-1
- **Connection Flange Size** – 24 in.
- **Serial Number**
- **Tag Number** (Optional)
- **Notified Body Number** – Ex. 2460
- **Cat. No.** (Category Number)
 - Category 1 – Stainless steel, Carbon steel or Coated aluminum vents
 - Category 2 – uncoated aluminum vents
- **Date** – date of manufacture
- **Certificate** – Ex. PRESAFE 17 ATEX 10273X
- **Pressure Setting and Flow Rate**
 - **Setting** – Ex. Z4.0
 - **Flow Rate SCFH (Air)** – Ex. 00000
- **Vacuum Setting and Flow Rate (2500 Series only)**
 - **Setting** – Ex. Z0.5
 - **Flow Rate SCFH (Air)** – Ex. 00000

Teflon® and Viton® are marks owned by E. I. du Pont de Nemours and Company.

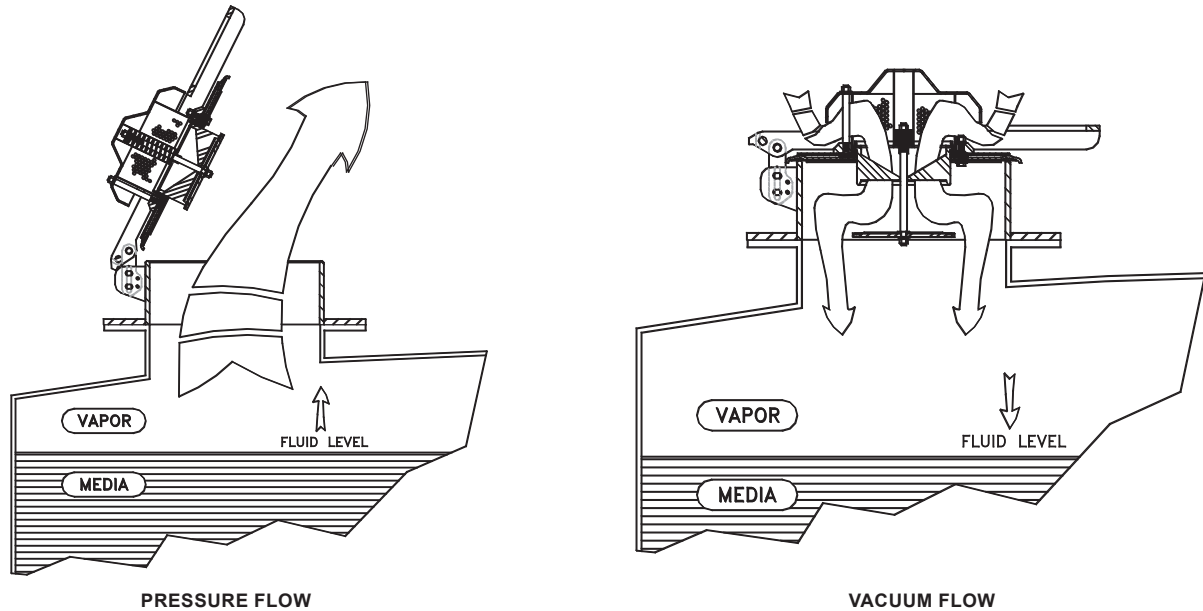

Figure 6. Pressure and Vacuum Flow

PPE Warning

WARNING

Wear protective gloves and clothing to prevent skin contact when handling lead weights. Wear eye protection. Avoid breathing dust/fumes/mist/vapors/spray. Do not eat, drink or smoke while using the product. Avoid release to the environment. Wash hands with soap and water after handling. Keep away from excessive heat and open flames.

WARNING

Make sure line is free of hazardous vapors before installing or servicing the valve.

Principle of Operation

Refer to Figure 6. The 2000 and 2500 Series maintain a tight seal until system pressure or vacuum exceeds the set pressure of the vent. To adjust the set pressure, a series of weights may be stacked onto the lid assembly. When overpressure occurs, the weighted lid assembly lifts, breaking the seal between the seat and seal portion of the lid assembly. This allows vapors to pass through the vent orifice and relieve pressure build up. The vent reseals upon relief and remains sealed.

It is important to note that relieving vapors near the set pressure in a continuous manner may cause the lid assembly to flutter or oscillate. This is a common occurrence in products of this type in the industry. Operating the vent with flutter or oscillation over time may cause premature vent damage or wear. Contact your local Sales Office for additional assistance.

Remote Monitoring Option

The Smart Wireless option for the 2000 Series consists of the EPRV, a proximity sensor, and a wireless transmitter. The built-in proximity sensor detects the open or closed position using a magnetic target located on the arm assembly on the hinged end. A signal is sent to the wireless transmitter, which can then be sent to a control room via any WirelessHART® Gateway. This wireless sensor networking technology is based on the Highly Addressable Remote Transducer (HART®) protocol. It is the most widely used wireless networking standard used today and, for this reason, the 2000 Series has been designed to integrate with it. As long as the wireless gateway is WirelessHART®, it will receive the Open or Closed signal from the device. The WirelessHART® gateway will then send the information to a control room which can make use of any number of software integration packages.

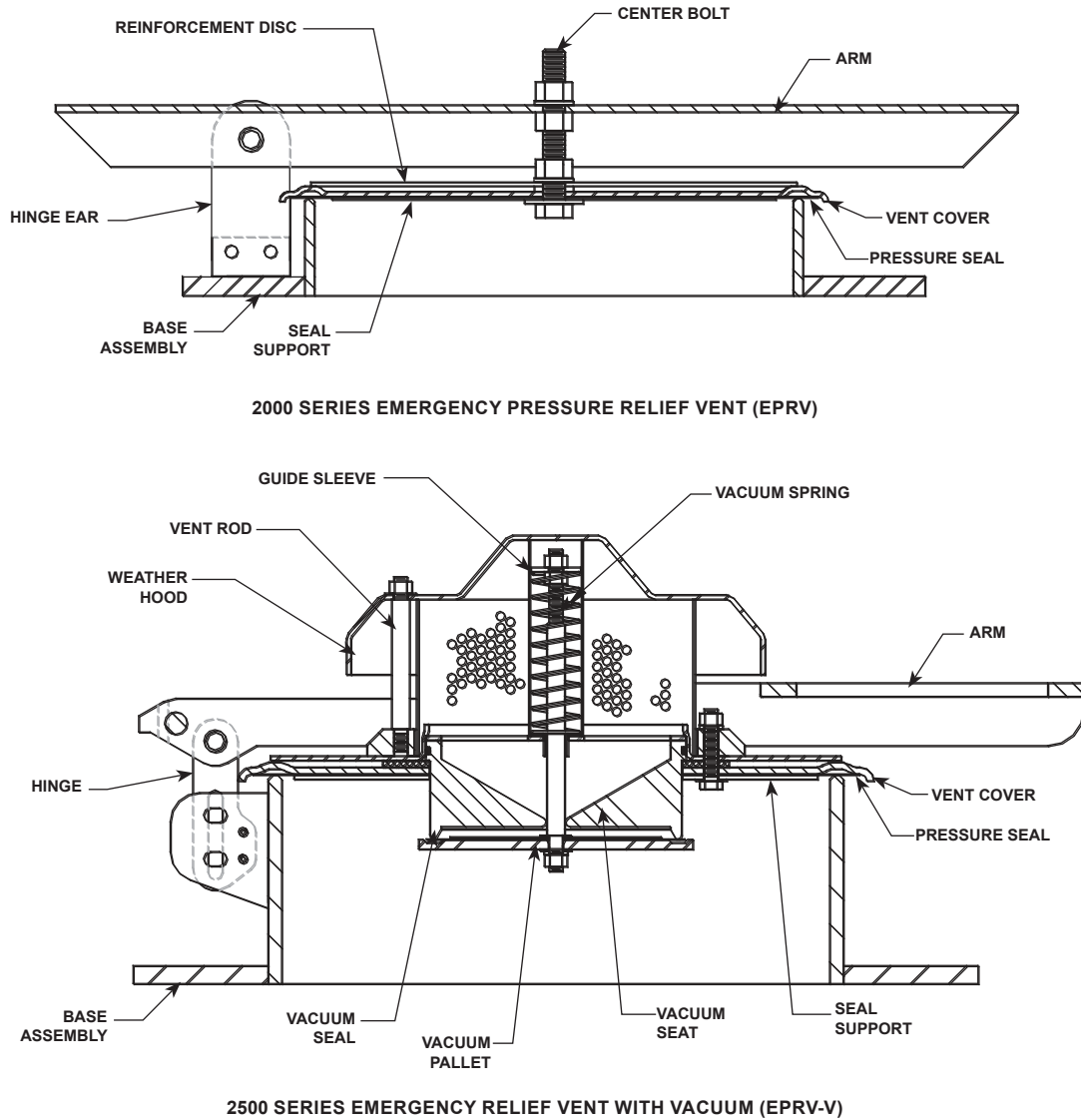

2000 SERIES EMERGENCY PRESSURE RELIEF VENT (EPRV)

2500 SERIES EMERGENCY RELIEF VENT WITH VACUUM (EPRV-V)

Figure 7. 2000 and 2500 Series Assembly Drawing

North America Only

Installation

WARNING

The EPRV Series is shipped with its lid held partially open. The lid assembly has attached weights and is heavy. Use caution when removing the shipping blocks and metal bands to avoid injury to fingers and hands.

Before installing the relief vent, remove the unit from its crate and discard any protective coverings. Follow the instruction below for the installation of the 2000 and 2500 Series.

Install the 2000 and 2500 Series on the flange bolt patterns that match with bolt pattern of the vent. The attachment flange base should be at level surface.

1. Carefully remove the 2000 and 2500 Series from its crate. The seal portion of the vents is delicate, protect this surface while handling the unit.
2. Place the appropriate gasket on the level attachment flange and center the vent into place.
3. Insert the appropriate number of bolts and make sure the vent is fastened securely. Installed bolts should be clear of the lid assembly when it is in the full open position.
4. Inspect the installed unit from items that would keep it from working properly. The sealing area should be free of any debris that would cause leakage. The arm of the vent should be able to fully open.

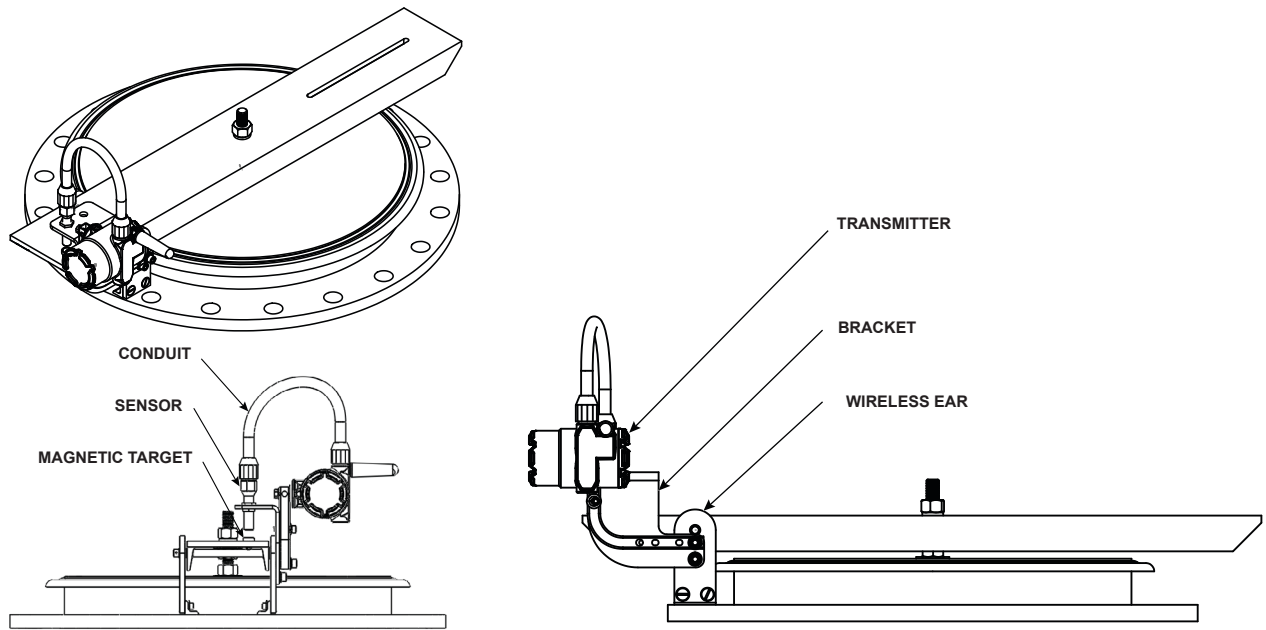

Figure 8. Enardo 2000 Smart Wireless Monitoring Option

Maintenance



WARNING

Always make sure that the tank is at atmospheric pressure before opening. pressure build-up inside the tank can cause a spray to be emitted from the vent if opened under pressure.

Follow the instruction below for the preventive maintenance of the 2000 and 2500 Series.

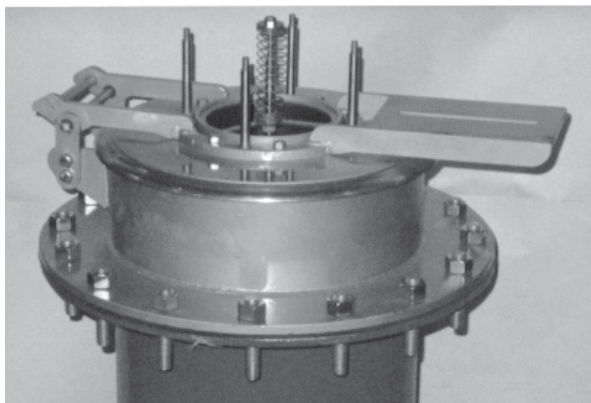

1. Loosen fasteners on top of the vent and remove the hood and the spring chamber.

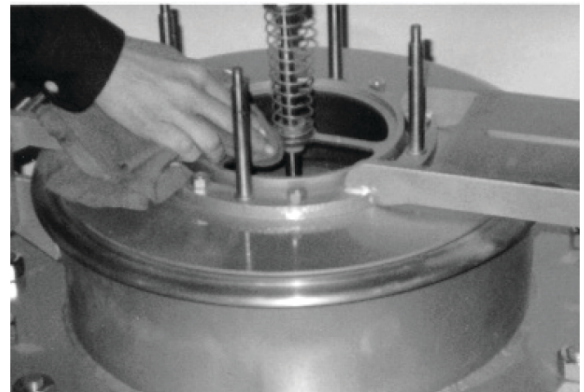

2. Inspect and clear away any debris or buildup that may cause the vent to become lodged or impede air flow through the unit. Do not adjust the height of the installed spring. Clean the internal components with a suitable solvent and non-abrasive cloth.

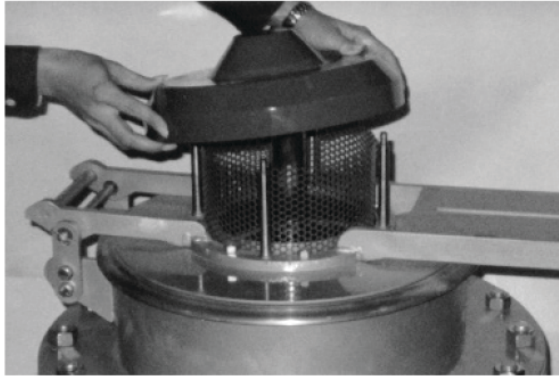

3. Replace the spring chamber and hood. Fasten them securely.

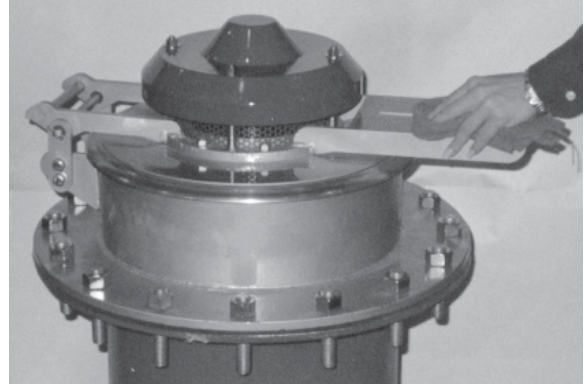

4. Clear away any debris or buildup on the unit surface that may cause the vent to become lodged, impede air flow or add weight to the lid assembly (added weight will adjust the pressure setting of the vent).

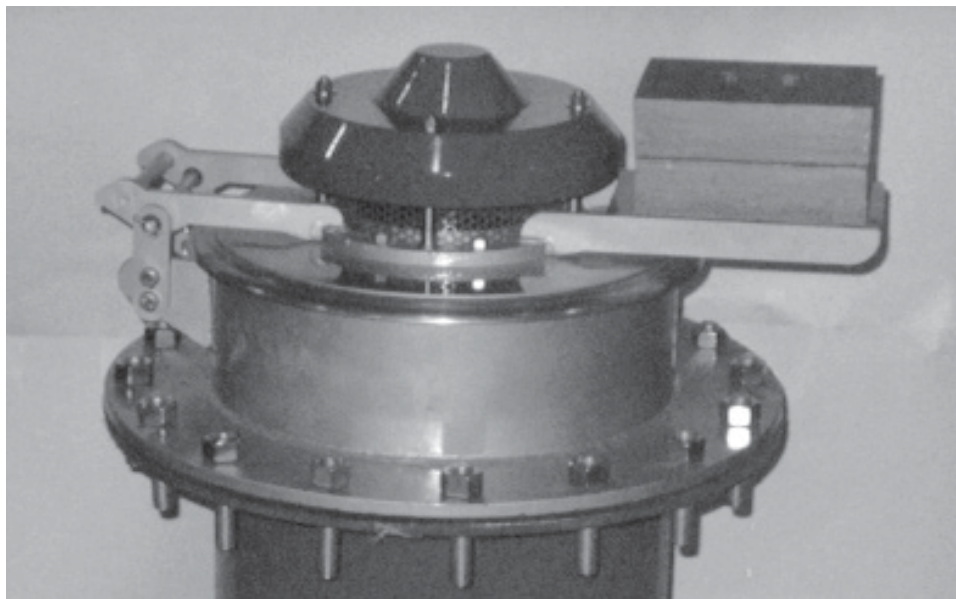

Figure 9. 2500 Series with an Elevated Pressure Setting

Remote Monitoring Maintenance

1. Maintain Smart Wireless Model 2000 EPRV's in the same way as all standard EPRV's.
2. Take certain precautions when cleaning the transmitter. The surface resistivity of the antenna assembly is greater than 1 GΩ. To avoid electrostatic charge build-up, it must not be rubbed or cleaned with solvents or dry cloth.

Pressure and Vacuum Setting Information

Both the 2000 and 2500 Series can reach various pressure settings in units of ounces or inches of water column. The minimum pressure setting that each vent can achieve

depends on the individual vent size and material. Minimum settings are reached when the unit is installed by itself. However, when weights are added to the arm of the unit, elevated pressures can be reached. These elevated settings are preset at the factory and should never be field adjusted.

Vacuum settings for the 2500 Series are set with a spring. For each setting that Enardo offers, there is a spring that is specifically designed to do the job. The standard settings available are 0.5, 0.75, 1 and 2 oz. Once again, these settings are preset at the factory and should never be field adjusted.

2000 and 2500 Series

Table 2. Torque Specifications - Raised Face Flange, Steel only

NOMINAL PIPE DIAMETER	# BOLTS	BOLT DIAMETER, IN.	TORQUE, FT-LBS.
4	8	0.63	43
8	8	0.75	109
10	12	0.88	101
12	12	0.88	135
16	16	1.00	159
18	16	1.13	244
20	20	1.13	214
24	24	1.25	253

Assumptions:
 Use of SAE grade 5 bolts or studs or stronger
 No lubricant
 Compressed mineral fiber material or similar

Notes:
 If lubricant is used on bolts, apply torque reduction factor listed in Lubricant Table.
 For best results hardened steel washers should be used on all cast flange bolted connections.

Table 3. Torque Specifications - Flat Face Flange, Steel or Aluminum

NOMINAL PIPE DIAMETER	# BOLTS	BOLT DIAMETER, IN.	TORQUE, FT-LBS.
4	8	0.63	32
8	8	0.75	68
10	12	0.88	69
12	12	0.88	98
16	16	1.00	125
18	16	1.13	142
20	20	1.13	135
24	24	1.25	156
8 API	16	0.50	20
20 API	16	0.63	75
24 API	20	0.63	75

Assumptions:
 Use of SAE grade 5 bolts or studs or stronger
 No lubricant
 Elastomer <70 Durometer Shore A

Notes:
 Flat faced flanges should never be mated to a raised face flange for installation.
 If lubricant is used on bolts, apply torque reduction factor listed in Lubricant Table.
 For best results hardened steel washers should be used on all cast flange bolted connections.

Table 4. Torque Reduction Factor per Lubricant

DESCRIPTION	COEFFICIENT OF FRICTION	MULTIPLY TORQUE VALUE IN TABLE BY
Machine Oil	f = 0.15	0.75
API SA2 Grease	f = 0.12	0.60
Nickel-based Lubricant	f = 0.11	0.55
Copper-based Lubricant	f = 0.10	0.50
Heavy-duty Lubricating Past	f = 0.06	0.30

✉ Webadmin.Regulators@emerson.com

Facebook.com/EmersonAutomationSolutions

🔍 Enardo.com

LinkedIn.com/company/emerson-automation-solutions

Twitter.com/emr_automation

Emerson Automation Solutions

Americas

McKinney, Texas 75070 USA
 T +1 800 558 5853
 +1 972 548 3574
 Tulsa, OK 74146 USA
 T +1 918 662 6161

Europe

Bologna 40013, Italy
 T +39 051 419 0611

Asia Pacific

Singapore 128461, Singapore
 T +65 6777 8211

Middle East and Africa

Dubai, United Arab Emirates
 T +971 4 811 8100

D103817X012 © 2015, 2021 Emerson Process Management Regulator Technologies, Inc. All rights reserved. 12/21.
 The Emerson logo is a trademark and service mark of Emerson Electric Co. All other marks are the property of their prospective owners. Enardo™ is a mark owned by Regulator Technologies Tulsa, LLC, a business of Emerson Automation Solutions.

The contents of this publication are presented for informational purposes only, and while every effort has been made to ensure their accuracy, they are not to be construed as warranties or guarantees, express or implied, regarding the products or services described herein or their use or applicability. All sales are governed by our terms and conditions, which are available upon request. We reserve the right to modify or improve the designs or specifications of such products at any time without notice.

Emerson Process Management Regulator Technologies Tulsa, LLC does not assume responsibility for the selection, use or maintenance of any product. Responsibility for proper selection, use and maintenance of any Emerson Process Management Regulator Technologies Tulsa, LLC product remains solely with the purchaser.

