

Type ACE95 and Type ACE95Sr Tank Blanketing Valves

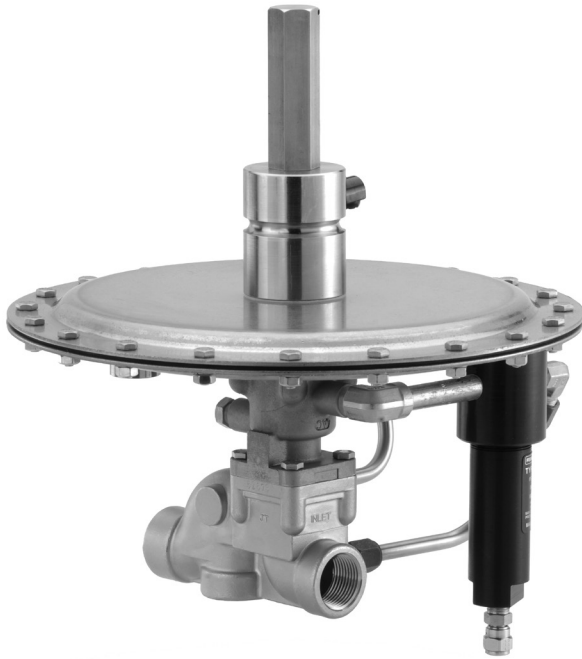

W9133

Figure 1. Type ACE95 Tank Blanketing Valve



W8155

Figure 2. Type ACE95Sr Tank Blanketing Valve

Introduction

Scope of the Manual

This instruction manual provides installation, startup and maintenance procedures for the ACE95 Series (Type ACE95 and Type ACE95Sr) tank blanketing valves. See Figures 1 and 2.

Product Description

The ACE95 Series tank blanketing valves are self-contained, balanced, pilot operated and used for accurate pressure control on gas blanketing systems. These valves help control emissions and provide protection against atmospheric contamination. The ACE95 Series valves maintain a positive pressure and thereby reduce the possibility of tank wall collapse during pump out operations, in addition to preventing liquid from vaporizing into the atmosphere.

ACE95 Series

Specifications

The Specifications section on this page provides specifications and ratings for ACE95 Series Tank Blanketing Valves. Factory specifications are stamped on a nameplate fastened to the upper actuator case of the valve.

Body Sizes and End Connection Styles

Type ACE95

Angled Body⁽¹⁾:

- 3/4 NPT
- 1 NPT
- NPS 1 / DN 25, CL150 RF
- NPS 1 / DN 25, CL300 RF
- NPS 1 / DN 25, PN 16/25/40 RF
- NPS 1 / DN 25 Sanitary Flange

In-line Body:

- 3/4 NPT
- 1 NPT
- NPS 1 / DN 25, CL150 RF
- NPS 1 / DN 25, CL300 RF
- NPS 1 / DN 25, PN 16/25/40 RF
- NPS 1 x 2 / DN 25 x 50, CL150 RF
- NPS 1 x 2 / DN 25 x 50, PN 16/25/40 RF
- NPS 1 / DN 25, Sanitary Flange

Type ACE95Sr

Angled Body⁽¹⁾:

- 2 NPT
- NPS 2 / DN 50, CL150 RF
- NPS 2 / DN 50, CL300 RF

Maximum Operating Inlet Pressure

200 psig / 13.8 bar

Maximum Outlet (casing) Pressure

20 psig / 1.4 bar

Maximum Operating Outlet Pressure

1.5 psig / 0.10 bar

Sour Gas Capability

Optional materials are available for applications handling sour gases. These constructions comply with the recommendations of NACE International Standards MR0175-2002, MR0103 and/or ANSI/NACE MR0175/ISO 15156.

Control Pressure Ranges

-5.0 in. w.c. to 1.5 psig / -12 mbar to 0.10 bar
See Table 1

Pressure Registration

External

Accuracy

Typically within 0.5 in. w.c. / 1 mbar when flowing
5 to 70 percent of advertised capacities.

Main Valve Flow Characteristic

Linear

Flow Coefficients for Relief Valve Sizing

Type ACE95

- C_v 1 use C_v 1.1
- C_v 2 use C_v 2.2
- C_v 4 use C_v 4.4
- C_v 7.5 use C_v 9.25
- C_v 10 use C_v 11

Type ACE95Sr

- C_v 20 use C_v 22
- C_v 45 use C_v 50
- C_v 60 use C_v 66

Material Temperature Capabilities⁽²⁾

Nitrile (NBR): -20 to 180°F / -29 to 82°C

Fluorocarbon (FKM): 0 to 212°F / -18 to 100°C

Ethylenepropylene (EPDM/FDA)⁽³⁾:

-20 to 212°F / -29 to 100°C

Perfluoroelastomer (FFKM):

-20 to 212°F / -29 to 100°C

Approximate Weights

With all accessories:

Type ACE95: 40 lbs / 18 kg

Type ACE95Sr: 60 lbs / 27 kg

1. Various Single Array Manifold (SAM) tank connections are also available. Contact your local Sales Office for more information.

2. Special low temperature constructions for process temperatures between -49 to 180°F / -45 to 82°C are available by request. The low temperature constructions passed Emerson laboratory testing for lockup and external leakage down to -49°F / -45°C.

3. FDA/USP Class VI approved/ADI-free elastomers (wetted parts only).

Table 1. Control Pressure Ranges

CONTROL PRESSURE RANGE		SPRING MATERIAL	SPRING FREE LENGTH		SPRING WIRE DIAMETER	
in. w.c.	mbar		in.	mm	in.	mm
-5 to -0.5	-12 to -1	Stainless steel	2.75 0.88 ⁽¹⁾	69.9 22.4 ⁽¹⁾	0.080 0.085 ⁽¹⁾	2.03 2.16 ⁽¹⁾
-1 to 1	-2 to 2	Stainless steel	2.75 1.60 ⁽¹⁾	69.9 40.6 ⁽¹⁾	0.080 0.065 ⁽¹⁾	2.03 1.65 ⁽¹⁾
0.5 to 5	1 to 12	Stainless steel	2.75	69.9	0.080	2.03
4 to 10	10 to 25	Stainless steel	2.00	50.8	0.112	2.84
8 to 15	20 to 37	Stainless steel	2.00	50.8	0.125	3.18
0.5 to 1.5 psig	0.03 to 0.10 bar	Stainless steel	2.75	69.9	0.225	5.72

1. The second spring is located under the diaphragm assembly.

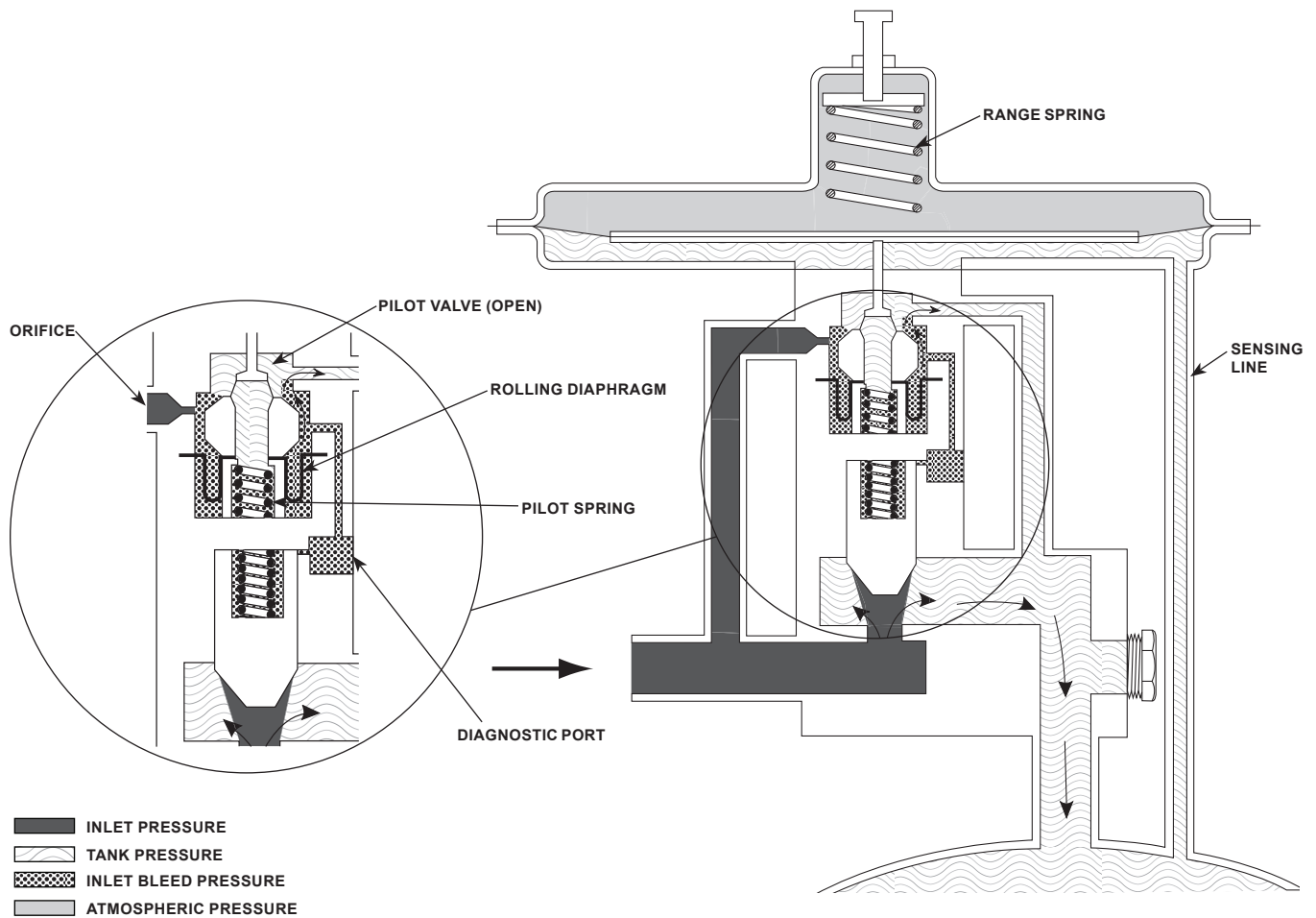

Figure 3. ACE95 Series Operational Schematic (Valve Open)

Principle of Operation

The ACE95 Series tank blanketing valves are pilot operated, activated by the diaphragm and control the vapor space pressure over a stored liquid. The unit is controlled by a very large diaphragm actuator. The oversized actuator offers high sensitivity to changes in tank pressure. When a storage tank cools and tank vapors condense, The ACE95 Series valves replace the condensing vapors with an inert gas to prevent internal tank pressure from decreasing. Positive tank pressure prevents outside air from contaminating the product and reduces the possibility of atmospheric pressure collapsing the tank. As demand is satisfied, the valve closes.

The ACE95 Series valves respond to slight decreases in internal tank pressure by opening and increasing the flow rate of inert gas into the tank. When the tank's liquid level has been lowered to the desired point and the vapor pressure setpoint is re-established, the valve closes.

Installation and Startup

WARNING

Personal injury, equipment damage or leakage due to escaping accumulated gas or bursting of pressure-containing parts may result if this gas blanketing system is overpressured or installed where service conditions could exceed the limits given in the Specifications section and on the appropriate nameplate or where conditions exceed any ratings of the adjacent piping or piping connections.

To avoid such injury or damage, provide pressure-relieving or pressure-limiting devices (as required by Title 49, Part 192, of the U.S. Code of Federal Regulations, by the National Fuel Gas Code Title 54 of the National Fire Codes of the National Fire Protection Agency or by other applicable codes) to prevent service conditions from exceeding those limits.

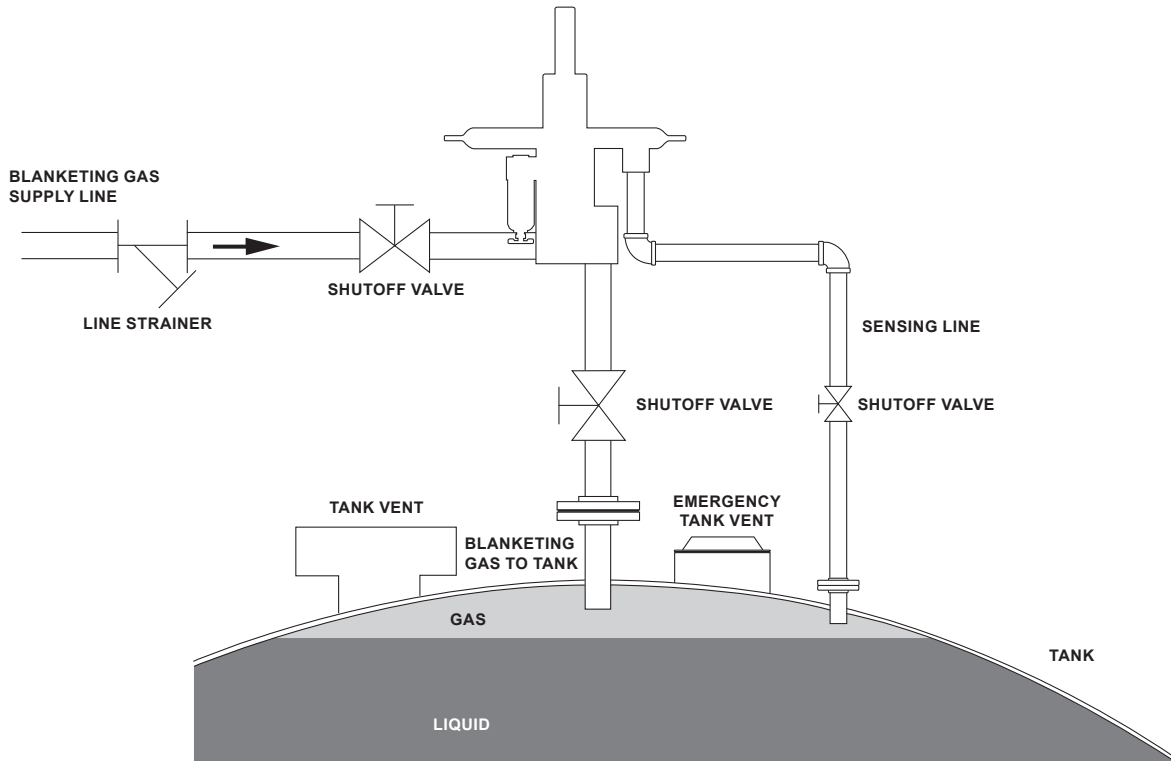

Figure 4. ACE95 Series Tank Blanketing Valve Installation

Additionally, physical damage to the tank blanketing system could result in personal injury and property damage due to escaping accumulated gas. To avoid such injury and damage, install the tank blanketing valve in a safe location.

This ACE95 Series valve was assembled and preset to the customer specified pressure and setpoint. The control pressure range of the valve is stamped on the nameplate fastened to the upper actuator case. The gas blanketing setpoint is the only adjustable feature on this unit.

1. Use qualified personnel when installing, operating and maintaining valves. Before installing, inspect the valve and tubing for any shipment damage or foreign material that may have collected. Make certain the body interior is clean and the pipelines are free of foreign material. Apply pipe compound only to the male pipe threads with a threaded body or use suitable line gaskets and good bolting practices with a flanged body.
2. Inspect the nameplate on the upper actuator case. It displays the model number, serial number, a blanketing gas supply pressure range and the maximum inlet pressure and set pressure. These must agree with the system that you are blanketing. The serial number will be needed in any communication with your local Sales Office.
3. Clean the gas blanketing supply lines of all dirt and foreign material before connecting them to the ACE95 Series tank blanketing valve.
4. The valve must be mounted so the actuator case is horizontal. The valve should be mounted above the tank. Three connections are required:
 - a) blanketing gas supply to valve,
 - b) valve outlet to tank and
 - c) sensing line to tank.

Piping Considerations



CAUTION

Undersized piping may inadequately deliver blanketing gas at the specified inlet pressure under full flow conditions. This may result in unacceptable performance under high demand conditions.

Unnecessarily long or restricted outlet piping may result in poor setpoint control.

Inlet Piping

The blanketing gas supply line should be equipped with a Number 100 mesh strainer to remove dirt and pipe scale. Inlet piping must be sized to adequately deliver blanketing gas at the specified inlet pressure under full flow conditions.

Outlet Piping

Type ACE95 or Type ACE95Sr valve outlet is piped into the tank vapor space. Outlet piping must be full size and self-draining to the tank. The valve should be situated above and as close as possible to the tank vapor space for best performance.

Sensing Line

The sensing line should be 1/2 in. / 13 mm tubing or pipe, must slope down toward the tank and should not contain low points (or traps) that could catch liquid. The sensing line must enter the tank above the liquid level at a point that senses the vapor space pressure and is free from turbulence associated with tank nozzles or vents.

Note

Best control is obtained when both connections to the tank are separate. If the tank has only one available nozzle, contact Emerson for alternate methods of installation. A single array manifold is available for such situations⁽¹⁾.

Gauges and Shutoff Valves

Inlet gas shutoff valves are desirable for servicing. If this ACE95 Series tank blanketing valve was not ordered with an inlet pressure gauge, it is advisable to install a gauge between the inlet shutoff valve and the blanketing valve.

Note

Safety considerations may dictate full port shutoff valves between the tank and blanketing valve and at the valve inlet.

Startup, Adjustment and Shutdown

Note

Tank vents and safety relief valves must be in place and operating.



Always open the outlet valve before the inlet valve. Operation in the reverse order could result in inlet pressure being applied to the actuator casing, potentially damaging it.

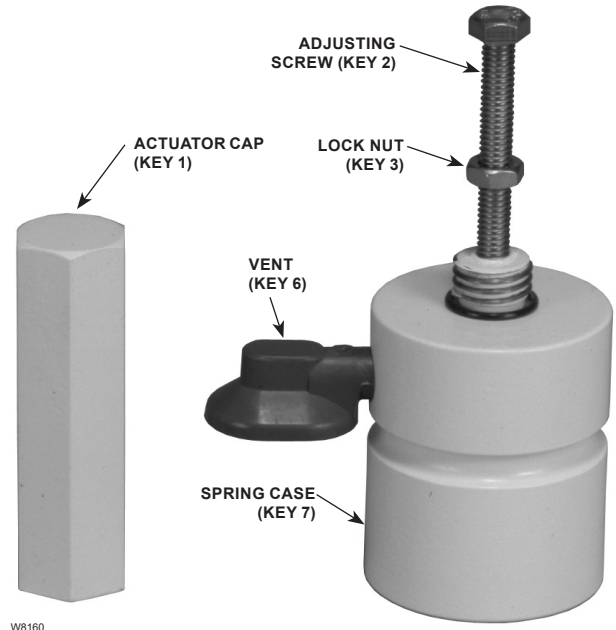

Figure 5. Spring Case, Adjusting Screw and Actuator Cap

Startup

1. Open shutoff valves between the blanketing valve and the tank (both sensing and outlet). See Figure 4.
2. Slowly open the supply line shutoff valve (to the blanketing valve) and leave it fully open.
3. Monitor the tank vapor space pressure.

Adjustment

The setpoint of this unit is factory set. If an adjustment is to be made, it should be done so in small increments while the unit is supplying gas to the tank. To change the setpoint:

1. Unscrew and remove the actuator cap (key 1) from the top of the spring case (key 7). See Figure 5.
2. Loosen the lock nut (key 3) and turn the adjusting screw (key 2) clockwise to raise the setpoint. (Turning the screw counter-clockwise lowers the setpoint.)
3. Observe the effects of the change.
4. When the adjustment is complete, tighten the lock nut (key 3) and replace the actuator cap (key 1).

Shutdown

Installation arrangements vary, but in any installation it is important to open and close valves slowly and to close the upstream shutoff valve first when shutting down the system.

1. Installation of single array manifold requires the blanketing gas supply pipe to extend into the vapor space a minimum of 6 in. / 152 mm beyond the tank roof.

Diagnostics

Note

If a diagnostics pressure gauge was not ordered with the unit, a pressure gauge must be installed in the diagnostic port to perform diagnostic analysis.

Diagnostics are an optional feature of the ACE95 Series Tank Blanketing valves that aid in evaluating valve operation. The diagnostic analysis relies on the relationship of pilot pressure and pressure in the main valve chambers (see Figure 3). The basic relationships are as follows:

In order to evaluate a valve, examine the valve nameplate to determine the C_v and inlet pressure range main valve spring. The inlet pressure gauge indicates actual pressure supplied to the valve.

Follow these steps and refer to the diagnostics tables on the following pages to evaluate a valve under actual operating conditions:

1. Select the Table (Tables 3 through 8) that corresponds to the C_v and inlet pressure range of your valve.
2. Determine the actual valve operating inlet pressure in the first column of the diagnostics table.

Table 2. Diagnostic Analysis Pressure Ranges

DIAGNOSTIC (PRESSURE CHAMBER)	STATUS
Equal to inlet supply pressure	Pilot and main valves are closed. Tank at or above set pressure.
Slightly below inlet supply pressure	Pilot valve supplies gas to tank. Tank pressure is just below set pressure.
Well below inlet supply pressure	Pilot and main valves are both supplying gas to the tank. Tank pressure is below setpoint.

3. In the second column of the table, determine the pressure of the pilot as it opens.
4. Determine the diagnostic pressure for the start to open pressure of the main valve in the third column.
5. The fourth column displays the diagnostic pressure for the full open pressure of the main valve.

There are four pressures involved in evaluating a valve: actual inlet pressure, pressure to start opening pilot valve, pressure to start opening main valve and pressure to fully open main valve.

Actual Inlet Pressure: The gas pressure supplied to the inlet of the valve. This is the maximum diagnostic pressure.

Pressure to Start Opening Pilot Valve: The diagnostic pressure drops to this value as the valve senses decreasing tank pressure. The main valve remains closed at this pressure.

Pressure to Start Opening Main Valve: The diagnostic pressure drops to this level as the tank pressure decreases and reaches the valve setpoint. The pilot is fully open at this pressure.

Pressure to Fully Open Main Valve: At this point, both the main valve and pilot valve are fully open and supplying gas to the tank.

Maintenance

Valve parts are subject to normal wear and must be inspected and replaced as necessary. The frequency of inspection and replacement of parts depends on the severity of service conditions and the requirements of local, state and federal regulations. Due to the care Emerson takes in meeting all manufacturing requirements, use only replacement parts manufactured or furnished by Emerson.

All O-rings, gaskets and seals should be lubricated with a good grade of general purpose lubricant and installed gently rather than forced into position. Suggested lubricant, sealant and adhesive are as follows:

Lubricant: Dow Corning® 111 or equivalent

Sealant: Loctite® PST #592, Polytetrafluoroethylene (PTFE) Tape or equivalent

Adhesive: Loctite® #222 or equivalent

Be certain that nameplates are updated to accurately indicate any field changes in equipment, materials, service conditions or pressure settings.

Monthly Maintenance

1. Visually inspect the unit to ensure tight connections, tight seals and safe operation.
2. Observe the blanketing pressure.
3. Inspect the inlet pressure for the proper pressure range (stamped on the valve nameplate).

Annual Maintenance

1. Visually inspect the unit to ensure tight connections, tight seals and safe operation.
2. Observe the blanketing pressure.
3. Inspect the inlet pressure for the proper pressure range (stamped on the valve nameplate).
4. Visually inspect valve for any external wear.
5. If there is evidence of leakage or unstable internal motion, a rebuild with seal replacement and relubrication may be in order.

Table 3. Type ACE95 Diagnostics Table: C_v 1 through 4, Inlet Pressure Range Spring 25 to 50 psig / 1.7 to 3.4 bar

ACTUAL INLET SUPPLY PRESSURE TO VALVE		DIAGNOSTIC PORT PRESSURE					
		When Pilot Starts to Open		When Main Valve Starts to Open		When Main Valve is Fully Open	
psig	bar	psig	bar	psig	bar	psig	bar
25	1.7	24	1.7	9	0.62	2	0.14
30	2.1	29	2.0	13	0.90	6	0.41
35	2.4	34	2.3	16	1.1	9	0.62
40	2.8	39	2.7	20	1.4	13	0.90
45	3.1	44	3.0	24	1.7	17	1.2
50	3.4	49	3.4	28	1.9	21	1.4

Table 4. Type ACE95 Diagnostics Table: C_v 1 through 4, Inlet Pressure Range Spring 51 to 120 psig / 3.5 to 8.3 bar

ACTUAL INLET SUPPLY PRESSURE TO VALVE		DIAGNOSTIC PORT PRESSURE					
		When Pilot Starts to Open		When Main Valve Starts to Open		When Main Valve is Fully Open	
psig	bar	psig	bar	psig	bar	psig	bar
51	3.5	50	3.4	29	2.0	5	0.35
60	4.1	59	4.1	36	2.5	12	0.83
70	4.8	69	4.8	43	3.0	19	1.3
80	5.5	79	5.4	51	3.5	27	1.9
90	6.2	89	6.1	59	4.1	34	2.3
100	6.9	99	6.8	66	4.6	42	2.9
110	7.6	109	7.5	74	5.1	50	3.4
120	8.3	119	8.2	81	5.6	57	3.9

Disassembly and Assembly

CAUTION

Before removing the valve from the line, ensure that it is isolated from the gas supply pressure and that all pressure has been released from the valve. (The drain on the inlet filter is convenient to bleed off gas.) All tank connections must be closed or sealed in accordance with your plant's operating and safety procedures. If installed, electrical connections to the explosion proof switch must be deactivated before opening the enclosure or disconnecting the wiring (in accordance with codes and safety practices).

It is recommended that all seals and diaphragms be replaced as a matter of good practice whenever a valve is disassembled and re-assembled. Parts kits are available through your local Sales Office.

If you are performing disassembly or assembly operations on a Type ACE95Sr valve, refer to the Parts List and see Figure 9. If you are working on a Type ACE95 valve, refer to the Parts List and see Figure 8.

Note

Have your model number, serial number, inlet pressure and set pressure range, C_v value and tank vent/relief setting available when ordering parts. Valve information is on the nameplate (on the upper actuator case).

Disassembly

WARNING

To avoid personal injury resulting from sudden release of pressure, isolate the valve from all pressure and cautiously release trapped pressure from the pilot or valve before attempting disassembly.

Spring Case Disassembly

1. Remove the actuator cap (key 1) and the spring load by unthreading the adjusting screw (key 2). See Figure 5.
2. Unthread the hex-head screws, lock washers and nuts (keys 32, 28 and 31) from the upper and lower actuator cases (keys 33 and 30). Lift the upper actuator case from the lower actuator case.
3. Remove the spring seat and range spring (keys 5 and 8).

ACE95 Series

Table 5. Type ACE95 Diagnostics Table: C_v 1 through 4, Inlet Pressure Range Spring 121 to 200 psig / 8.3 to 13.8 bar

ACTUAL INLET SUPPLY PRESSURE TO VALVE		DIAGNOSTIC PORT PRESSURE					
		When Pilot Starts to Open		When Main Valve Starts to Open		When Main Valve is Fully Open	
psig	bar	psig	bar	psig	bar	psig	bar
121	8.3	120	8.3	74	5.1	30	2.1
130	9.0	129	8.9	81	5.6	37	2.6
140	9.7	139	9.6	88	6.1	45	3.1
150	10.3	149	10.3	96	6.6	53	3.7
160	11.0	159	11.0	104	7.2	60	4.1
170	11.7	169	11.7	111	7.7	68	4.7
180	12.4	179	12.3	119	8.2	75	5.2
190	13.1	189	13.0	127	8.8	83	5.7
200	13.8	199	13.7	134	9.2	91	6.3

Table 6. Type ACE95 Diagnostics Table: C_v 7.5 and 10, Inlet Pressure Range Spring 25 to 50 psig / 1.7 to 3.4 bar

ACTUAL INLET SUPPLY PRESSURE TO VALVE		DIAGNOSTIC PORT PRESSURE					
		When Pilot Starts to Open		When Main Valve Starts to Open		When Main Valve is Fully Open	
psig	bar	psig	bar	psig	bar	psig	bar
25	1.7	24	1.7	11	0.76	0	0.0
30	2.1	29	2.0	14	0.97	3	0.21
35	2.4	34	2.3	17	1.2	6	0.41
40	2.8	39	2.7	21	1.4	9	0.62
45	3.1	44	3.0	24	1.7	13	0.90
50	3.4	49	3.4	27	1.9	16	1.1

Actuator/Diaphragm Disassembly

1. Disassemble the diaphragm by unthreading the diaphragm retaining nut (key 13) from the diaphragm bolt (key 15).
2. Remove the upper and lower diaphragm plates (keys 10 and 48) and the diaphragm (key 11). [The actuator gasket (key 12) sits on top of the diaphragm.] In cases where the pressure range is positive, the upper diaphragm plate is larger than the lower diaphragm plate.
3. Remove the internal bonnet screws and lock washers (keys 54 and 55) that attach the lower actuator case (key 30) to the bonnet. Remove the lower actuator case and the actuator O-ring (key 53, Type ACE95) or gasket (key 27 Type ACE95Sr).
4. Remove the cap screws and lock washers (keys 28 and 29, Type ACE95 or keys 50 and 51, Type ACE95Sr) that attach the bonnet (key 17) to the body (key 18).
5. Lift the bonnet (key 17) from the body (key 18).

Note

Slightly rotating the bonnet may help loosen the O-ring (key 19).

Main Valve Disassembly

1. Remove the main valve (key 25) along with the main valve spring (key 26), spring shim (key 34)⁽¹⁾ and spring guide (key 49, Type ACE95Sr only) from the bonnet (key 17).
2. Unthread the screw (key 20) from the main valve.
3. Remove the plug (key 22) from the main valve (key 25). See Figure 7.
4. Insert wooden dowel rod (or similar blunt tool) through the bottom of the bonnet bore to remove the cage (keys 35 and 40) sub-assembly.

Pilot/Cage Disassembly



Do not wrench or bend the stem of the poppet (key 42). Use soft-jawed pliers to hold the piston without damaging it.

1. The upper cage (key 40) will readily separate from the lower cage (key 35). See Figure 6.
2. Gently press the poppet stem (key 42) to remove the pilot from the upper cage (key 40).
3. Insert a small drill bit into the cross-drilled hole on the poppet (key 42) to turn and loosen. Unthread the poppet from the piston (key 37). Remove the rolling diaphragm (key 38).

1. Type ACE95 with 25 to 50 psig / 1.7 to 3.4 bar inlet spring and C_v 1 through 4 only.

Table 7. Type ACE95 Diagnostics Table: C_v 7.5 and 10, Inlet Pressure Range Spring 51 to 120 psig / 3.5 to 8.3 bar

ACTUAL INLET SUPPLY PRESSURE TO VALVE		DIAGNOSTIC PORT PRESSURE					
		When Pilot Starts to Open		When Main Valve Starts to Open		When Main Valve is Fully Open	
psig	bar	psig	bar	psig	bar	psig	bar
51	3.5	50	3.4	24	1.7	3	0.21
60	4.1	59	4.1	30	2.1	9	0.62
70	4.8	69	4.8	36	2.5	15	1.0
80	5.5	79	5.4	42	2.9	22	1.5
90	6.2	89	6.1	49	3.4	28	1.9
100	6.9	99	6.8	55	3.8	34	2.3
110	7.6	109	7.5	61	4.2	41	2.8
120	8.3	119	8.2	68	4.7	47	3.2

Table 8. Type ACE95 Diagnostics Table: C_v 7.5 and 10, Inlet Pressure Range Spring 121 to 200 psig / 8.3 to 13.8 bar

ACTUAL INLET SUPPLY PRESSURE TO VALVE		DIAGNOSTIC PORT PRESSURE					
		When Pilot Starts to Open		When Main Valve Starts to Open		When Main Valve is Fully Open	
psig	bar	psig	bar	psig	bar	psig	bar
121	8.3	120	8.3	63	4.3	31	2.1
130	9.0	129	8.9	69	4.8	37	2.6
140	9.7	139	9.6	75	5.2	43	3.0
150	10.3	149	10.3	82	5.7	49	3.4
160	11.0	159	11.0	88	6.1	56	3.9
170	11.7	169	11.7	94	6.5	62	4.3
180	12.4	179	12.3	101	7.0	68	4.7
190	13.1	189	13.0	107	7.4	75	5.2
200	13.8	199	13.7	113	7.8	81	5.6

Assembly

When assembling the Type ACE95 or Type ACE95Sr tank blanketing valve, clean all parts, inspect for unusual wear and lightly lubricate all O-rings and the groove that locates the rolling diaphragm bead. See Figures 8 and 9.

Bonnet Sub-Assembly

Prepare the bonnet (key 17) by installing two (2) internal O-rings (key 16).

Pilot/Cage Sub-Assembly

Refer to Figures 6, 8 and 9 when performing pilot/cage sub-assembly operations.

1. Apply Loctite® #222 or equivalent to the piston threads. Place the rolling diaphragm (key 38) over the threaded portion of the piston (key 37). Position the bead as shown in Figure 6.
2. Thread the poppet (key 42) onto the piston (key 37). Use soft-jawed pliers to restrain the piston so it is not damaged. Do not hold the poppet by the poppet stem. Insert a small drill bit into the cross-drilled hole on the poppet stem (key 42) to turn and tighten.
3. Slide the O-ring (key 39) onto the poppet (key 42).
4. Place the pilot sub-assembly into the upper cage (key 40).

5. Press the lower cage (key 35) and upper cage (key 40) together to ensure the groove in the lower cage engages the bead on the rolling diaphragm (key 38).

Note

Ensure that the rolling diaphragm bead is positioned so that it sits in the groove of the lower cage (see Figures 8 and 9). If it does not, the rolling diaphragm was installed upside-down in Cage Sub-Assembly step 2.

6. Remove the lower cage (key 35).
7. Lubricate the piston (key 37) and lower cage (key 35) groove.
8. Install the pilot spring (key 36) into the piston (key 37) and re-install the lower cage (key 35).
9. Hold the pilot sub-assembly together and insert it into the bonnet (key 17). Press firmly (the bonnet O-rings will offer resistance).
10. Press the poppet stem. It should freely move up and down. If it does not, repeat the procedure to this point to determine the cause.

ACE95 Series

Table 9. Type ACE95Sr Diagnostics Table: C_v 20 through 60, Inlet Pressure Range Spring 25 to 50 psig / 1.7 to 3.4 bar

ACTUAL INLET SUPPLY PRESSURE TO VALVE		DIAGNOSTIC PORT PRESSURE					
		When Pilot Starts to Open		When Main Valve Starts to Open		When Main Valve is Fully Open	
psig	bar	psig	bar	psig	bar	psig	bar
25	1.7	24	1.7	16	1.1	5	0.35
30	2.1	29	2.0	20	1.4	9	0.62
35	2.4	34	2.3	24	1.7	14	0.97
40	2.8	39	2.7	29	2.0	18	1.2
45	3.1	44	3.0	33	2.3	23	1.6
50	3.4	49	3.4	38	2.6	27	1.9

Table 10. Type ACE95Sr Diagnostics Table: C_v 20 through 60, Inlet Pressure Range Spring 51 to 120 psig / 3.5 to 8.3 bar

ACTUAL INLET SUPPLY PRESSURE TO VALVE		DIAGNOSTIC PORT PRESSURE					
		When Pilot Starts to Open		When Main Valve Starts to Open		When Main Valve is Fully Open	
psig	bar	psig	bar	psig	bar	psig	bar
51	3.5	50	3.4	39	2.7	11	0.76
60	4.1	59	4.1	48	3.3	19	1.3
70	4.8	69	4.8	57	3.9	28	1.9
80	5.5	79	5.4	66	4.6	37	2.6
90	6.2	89	6.1	75	5.2	46	3.2
100	6.9	99	6.8	84	5.8	55	3.8
110	7.6	109	7.5	93	6.4	64	4.4
120	8.3	119	8.2	102	7.0	73	5.0

Note

Use soft-jawed pliers to restrain the main valve (key 25) while applying Loctite® #222 or equivalent to the threads of the screw (key 20).

Main Valve Sub-Assembly

1. Prepare the main piston (key 25) by installing the plug and O-ring (keys 22 and 23) with the screw (key 20) and lock washer (key 21). Apply Loctite® #222 or equivalent to the screw threads.
2. Install the main valve spring (key 26), spring shim (key 34)⁽¹⁾ and spring guide valve [key 49, 25 to 50 psig / 1.7 to 3.4 bar / 51 to 120 psig / 3.5 to 8.3 bar, Type ACE95Sr only] into the piston (key 25).
3. Place the main valve sub-assembly [piston, spring and plug (keys 25, 26 and 22)] into the body (key 18).
4. Place an O-ring (key 19) into the body (key 18).

Body Sub-Assembly

1. Place the bonnet (key 17) onto the body (key 18) and main valve (key 25).
2. Press firmly to seat the bonnet O-ring joint. Attach the bonnet (key 17) to the body (key 18) with four cap screws and lock washers (keys 28 and 29, Type ACE95 or keys 50 and 51, Type ACE95Sr).
3. Place the actuator O-ring (key 53, Type ACE95) or gasket (key 27, Type ACE95Sr) and the lower actuator case (key 30) onto the bonnet (key 17).

4. Install lock washers (key 54) and hex-head screws (key 55).
5. Tighten all hex-head screws (key 29) uniformly.

Diaphragm Sub-Assembly

1. Place an O-ring (key 14) into the groove of the diaphragm bolt (key 15).
2. Build the diaphragm sub-assembly with the lower diaphragm plate (key 48), diaphragm (key 11) and upper diaphragm plate (key 10). Fasten the plates together with the diaphragm bolt (key 15) and the diaphragm retaining nut (key 13). The diaphragm retaining nut sits on the upper diaphragm plate. Apply Loctite® #222 or equivalent to the diaphragm bolt.

Note

Two different diaphragm plates are used when the pressure range is positive. In cases where the pressure range is positive, the upper diaphragm plate (key 10) is larger than the lower diaphragm plate (key 48).

3. If you are using a negative spring range, install the lower range spring (key 162) into the lower actuator case (key 30).
4. Place the diaphragm sub-assembly into the lower actuator case (key 30) with the diaphragm retaining nut (key 13) on top. Place the actuator gasket (key 12) on top of the diaphragm (key 11)

Loctite® is a mark owned by Henkel Corporation.

1. Type ACE95 with 25 to 50 psig / 1.7 to 3.4 bar inlet spring and C_v 1 through 4 only.

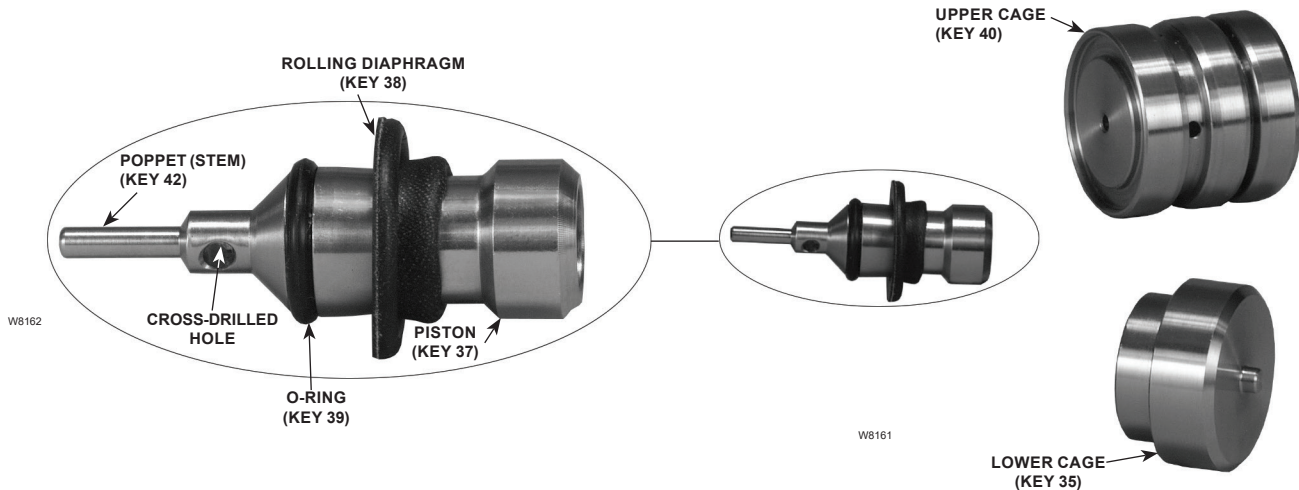

Figure 6. Cage Sub-Assembly

Table 11. Type ACE95Sr Diagnostics Table: C_v 20 through 60, Inlet Pressure Range Spring 121 to 200 psig / 8.3 to 13.8 bar

ACTUAL INLET SUPPLY PRESSURE TO VALVE		DIAGNOSTIC PORT PRESSURE					
		When Pilot Starts to Open		When Main Valve Starts to Open		When Main Valve is Fully Open	
psig	bar	psig	bar	psig	bar	psig	bar
121	8.3	120	8.3	103	7.1	60	4.1
130	9.0	129	8.9	111	7.7	68	4.7
140	9.7	139	9.6	120	8.3	77	5.3
150	10.3	149	10.3	129	8.9	86	5.9
160	11.0	159	11.0	138	9.5	95	6.6
170	11.7	169	11.7	147	10.1	104	7.2
180	12.4	179	12.3	156	10.8	113	7.8
190	13.1	189	13.0	165	11.4	122	8.4
200	13.8	199	13.7	174	12.0	134	9.2

and align the holes with those on the lower actuator case (key 30).

5. If it was removed, place the spring case gasket (key 9) between the spring case (key 7) and upper actuator case (key 33) before attaching the spring case to the upper actuator case. Attach the spring case to the upper actuator case with hex-head screws (key 32).
6. Place the range spring (key 8) and spring seat (key 5) onto the diaphragm sub-assembly over the diaphragm retaining nut (key 13).
7. Place the upper actuator case (key 33) over the range spring (key 8), spring seat (key 5) and the lower actuator case (key 30).
8. Build the actuator case by installing hex-head screws, lock washers and nuts (keys 32, 28 and 31) into the upper and lower actuator cases (keys 33 and 30). Use a washer (key 47) on steel cases.

9. Thread the range spring adjusting screw (key 2) in about halfway.
10. Tighten all nuts (key 31) uniformly.
11. Reinstall the valve according to the instructions in the Installation section of this manual.
12. Adjust the setpoint according to the instructions in the Adjustment section.
13. Replace the actuator cap (key 1).

Parts Ordering

Each ACE95 Series valve is assigned a serial number printed on the nameplate on the main valve actuator. Refer to this number when contacting your local Sales Office for assistance or when ordering replacement parts. When ordering a replacement part, be sure to reference the key number for each needed part and include the complete 11-character part number from the following parts list.

ACE95 Series

Parts List⁽¹⁾

Key	Description	Part Number
Parts Kits		
	Actuator Diaphragm and Gasket Kit (includes keys 9, 11 and 12) Types ACE95 and ACE95Sr	10C1273X012
	Rolling Diaphragm and Seal Kits (includes keys 4, 14, 16, 19, 23, 24, 27, 38, 39, 41) Type ACE95, C _v 1 through 4	
	Nitrile (NBR)	19B9098X012
	Ethylenepropylene (EPDM/FDA) ⁽²⁾	19B9098X032
	Fluorocarbon (FKM)	19B9098X022
	Perfluoroelastomer (FFKM)	19B9098X042
	Type ACE95, C _v 7.5 and 10	
	Nitrile (NBR)	19B9099X012
	Ethylenepropylene (EPDM/FDA) ⁽²⁾	19B9099X032
	Fluorocarbon (FKM)	19B9099X022
	Perfluoroelastomer (FFKM)	19B9099X042
	Type ACE95Sr	
	Nitrile (NBR)	19B6038X012
	Ethylenepropylene (EPDM/FDA) ⁽²⁾	19B6038X032
	Fluorocarbon (FKM)	19B6038X022
	Perfluoroelastomer (FFKM)	19B6038X042
1	Cap	
	Stainless steel	GC053301X02
	Steel	GC053301X32
2	Adjusting Screw	
	0.5 to 5 in. w.c. / 1 to 12 mbar	GC060216X12
	4 to 10 in. w.c. / 10 to 25 mbar	GC060216X12
	8 to 15 in. w.c. / 20 to 37 mbar	GC060216X12
	0.5 to 1.5 psi / 0.03 to 0.10 bar	GC060221X12
	-1.0 to 1.0 in. w.c. / -2 to 2 mbar	GC060216X12
	-5 to -0.5 in. w.c. (VAC) / -12 to -1 mbar	GC060216X12
3	Lock Nut	GC060313X02
4*	O-ring	
	Nitrile (NBR)	1F463606992
	Ethylenepropylene (EPDM/FDA) ⁽²⁾	1F4636X0082
	Fluorocarbon (FKM)	1N571406382
	Perfluoroelastomer (FFKM)	1F4636X0052
5	Spring Seat	GC050502X02
6	Vent (Type Y602-A12)	27A5516X012
7	Spring Case	
	Stainless steel	GC053101X02
	Steel	GC053101X32
8	Range Spring	
	0.5 to 5 in. w.c. / 1.2 to 12.4 mbar	GC220701X22
	4 to 10 in. w.c. / 10 to 25 mbar	GC220702X22
	8 to 15 in. w.c. / 20 to 37 mbar	GC220703X22
	0.5 to 1.5 psi / 0.03 to 0.10 bar	GC220708X22
	-1.0 to 1.0 in. w.c. / -2 to 2 mbar	GC220701X22
	-5 to -0.5 in. w.c. (VAC) / -12 to -1 mbar	GC220701X22
9*	Gasket (spring tower)	GC070428X02
10	Diaphragm Plate (upper)	GC260104X02
11	Diaphragm (main) - FEP ⁽²⁾	GC070234X72
12*	Gasket (actuator)	GC070427X02
13	Diaphragm Retaining Nut	GC053215X02
14*	O-ring	
	Nitrile (NBR)	GC070173X02
	Ethylenepropylene (EPDM/FDA) ⁽²⁾	GC070173X52
	Fluorocarbon (FKM)	GC070173X12
	Perfluoroelastomer (FFKM)	GC070173X62
15	Diaphragm Bolt	GC053210X02
16*	O-ring (2 required)	
	Nitrile (NBR)	1F115306992
	Ethylenepropylene (EPDM/FDA) ⁽²⁾	1F1153X0062
	Fluorocarbon (FKM)	1F1153X0022
	Perfluoroelastomer (FFKM)	1F1153X0032

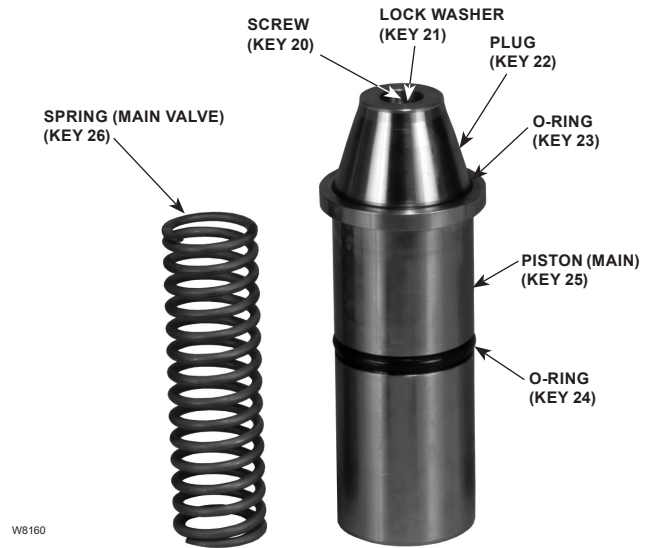

Figure 7. Typical Main Valve and Spring (Type ACE95Sr shown)

Key	Description	Part Number
17	Bonnet	
	C _v 1 through 4	GC050929X12
	C _v 7.5 and 10	GC050929X02
	C _v 20 through 60	GC050919X62
18	Body	
	C _v 1 through 4	
	3/4 NPT	GE02625X012
	1 NPT	GE02623X012
	C _v 7.5 and 10	
	1 NPT	GE02627X012
	C _v 20 through 60	
	2 NPT	GC050927X62
19*	O-ring	
	Type ACE95	
	Nitrile (NBR)	1C415706992
	Ethylenepropylene (EPDM/FDA) ⁽²⁾	1C4157X0092
	Fluorocarbon (FKM)	1C4157X0032
	Perfluoroelastomer (FFKM)	1C4157X0082
	Type ACE95Sr	
	Nitrile (NBR)	1F3581X0082
	Ethylenepropylene (EPDM/FDA) ⁽²⁾	1F3581X0102
	Fluorocarbon (FKM)	1F3581X0022
	Perfluoroelastomer (FFKM)	1F3581X0092
20	Round-Head Machine Screw	
	Type ACE95	
	NACE	1A3776X0012
	Type ACE95Sr	1A3776X0042
	NACE	GC060225X02
	NACE	GC060225X02
21	Lock Washer	
	Type ACE95	GC060903X02
	Type ACE95Sr	GC060906X02
22	Plug	
	Type ACE95	
	C _v 1	GC053206X02
	C _v 2	GC053205X02
	C _v 4	GC053204X02
	C _v 7.5	GC053213X02
	C _v 10	GC053212X02
	Type ACE95Sr	
	C _v 20	GC053220X02
	C _v 45	GC053221X02
	C _v 60	GC053218X02

* Recommended Spare Part

- Wetted stainless steel components meet the chemical and physical requirements of NACE MR0175-2002, NACE MR0103 and/or NACE MR0175/ISO 15156 unless otherwise specified.
- FDA/USP Class VI approved/ADI-free elastomers (wetted parts only).

ACE95 Series

Key	Description	Part Number	Key	Description	Part Number
23*	O-ring Type ACE95, C _v 1 through 4 Nitrile (NBR) Ethylenepropylene (EPDM/FDA) ⁽¹⁾ Fluorocarbon (FKM) Perfluoroelastomer (FFKM) Type ACE95, C _v 7.5 and 10 Nitrile (NBR) Ethylenepropylene (EPDM/FDA) ⁽¹⁾ Fluorocarbon (FKM) Perfluoroelastomer (FFKM) Type ACE95Sr C _v 20 through 60 Nitrile (NBR) Ethylenepropylene (EPDM/FDA) ⁽¹⁾ Fluorocarbon (FKM) Perfluoroelastomer (FFKM)	1D2888X0032 1D2888X0042 1D2888X0052 1D2888X0022 18A1088X022 18A1088X042 18A1088X052 18A1088X032 1C628006992 1C6280X0102 1C6280X0012 1C6280X0092	33	Actuator Case (upper) Stainless steel Steel	GC260102X02 GC260102X12
24*	O-ring Type ACE95 C _v 1 through 4 Nitrile (NBR) Ethylenepropylene (EPDM/FDA) ⁽¹⁾ Fluorocarbon (FKM) Perfluoroelastomer (FFKM) Type ACE95 C _v 7.5 and 10 Nitrile (NBR) Ethylenepropylene (EPDM/FDA) ⁽¹⁾ Fluorocarbon (FKM) Perfluoroelastomer (FFKM) Type ACE95Sr C _v 20 through 60 Nitrile (NBR) Ethylenepropylene (EPDM/FDA) ⁽¹⁾ Fluorocarbon (FKM) Perfluoroelastomer (FFKM)	1C782206992 1C7822X0122 1C7822X0132 1C7822X0112 1D2375X0062 1D2375X0082 1D237506382 1D2375X0072 1D785306992 1D7853X0032 1D7853X0042 1D7853X0012	34	Type ACE95, C _v 1 through 4 25 to 50 psig / 1.7 to 3.4 bar Spring Shim Lower Cage Spring (cage) Piston (pilot) 38* Rolling Diaphragm Nitrile (NBR) Ethylenepropylene (EPDM/FDA) ⁽¹⁾ Fluorocarbon (FKM) Perfluoroelastomer (FFKM) 39* O-ring Nitrile (NBR) Ethylenepropylene (EPDM/FDA) ⁽¹⁾ Fluorocarbon (FKM) Perfluoroelastomer (FFKM)	GC053209X02 GC053002X02 GC220707X22 GC053202X02 GC071101X02 GC071101X22 GC071101X12 GC071101X32 1D2888X0032 1D2888X0042 1D2888X0052 1D2888X0022 GC053001X02 10A0042X052 10A0042X072 10A0042X012 10A0042X062 GC053201X02 10C1269X022 10C1269X012 GC260113X02 GC260113X12
25	Piston (main valve) Type ACE95: C _v 1 through 4 Type ACE95: C _v 7.5 and 10 Type ACE95Sr: C _v 20 through 60	GC053203X02 GC053211X02 GC053219X02	40	Cage (upper)	GC053001X02
26	Spring (main valve) Type ACE95 C _v 1 through 4, 25 to 50 psig / 1.7 to 3.4 bar C _v 1 through 4, 51 to 120 psig / 3.5 to 8.3 bar C _v 1 through 4, 121 to 200 psig / 8.3 to 13.8 bar C _v 7.5 and 10, 25 to 50 psig / 1.7 to 3.4 bar C _v 7.5 and 10, 51 to 120 psig / 3.5 to 8.3 bar C _v 7.5 and 10, 121 to 200 psig / 8.3 to 13.8 bar Type ACE95Sr C _v 20 through 60, 25 to 50 psig / 1.7 to 3.4 bar C _v 20 through 60, 51 to 120 psig / 3.5 to 8.3 bar C _v 20 through 60, 121 to 200 psig / 8.3 to 13.8 bar	GC220704X22 GC220705X22 GC220706X22 GC220705X22 GC220706X22 GC220709X22 GC220714X22 GC220712X22 GC220713X22 GC070429X32	41* O-ring Nitrile (NBR) Ethylenepropylene (EPDM/FDA) ⁽¹⁾ Fluorocarbon (FKM) Perfluoroelastomer (FFKM) 42 Pilot (poppet) 43 Pilot Filter (optional, not shown) Aluminum Stainless steel 48 Diaphragm Plate (lower) Positive Spring Range [3 in. / 76 mm - diameter] NACE Negative Spring Range [9 in. / 229 mm - diameter] NACE 49 Spring Guide (Type ACE95Sr only) 25 to 50 psig / 1.7 to 3.4 bar 51 to 120 psig / 3.5 to 8.3 bar 50 Hex Head Cap Screw (4 required) 51 Lock Washer (4 required) 53* O-ring (Type ACE95 Only) Nitrile (NBR) Ethylenepropylene (EPDM/FDA) ⁽¹⁾ Fluorocarbon (FKM) Perfluoroelastomer (FFKM) 54 Washer (4 required) Standard NACE 55 Hex Head Machine Screw (4 required) Standard NACE 138 Hex-Head Pipe Plug (Type ACE95 Only) NPS 3/4 body NPS 1 / DN 25 body 139 Hex-Head Pipe Plug 162 Lower Range Spring [negative pressure range only, used with upper spring (key 8)] -1.0 to 1.0 in. w.c. / -2 to 2 mbar -5 to -0.5 in. w.c. (VAC) / -12 to -1 mbar 168 Sealant 169 Lubricant	10A0042X072 10A0042X012 10A0042X062 GC053201X02 10C1269X022 10C1269X012 GC260113X02 GC260113X12 GC260104X02 GC260104X12 GC050505X22 GC060224X12 GC060905X02 1H991206992 1R3971X0012 1R397106382 1R3971X0022 GC060906X02 NE2012510A1 1A3917X0062 1A3917X0282 1A771535072 1A7947X0022 1A767535072 GC220717X22 GC220710X22 ----- -----	
27*	Gasket (bonnet/actuator) (Type ACE95Sr Only)	GC070429X32	43	Pilot Filter (optional, not shown)	10C1269X022 10C1269X012
28	Lock Washer Type ACE95 (24 required) Type ACE95Sr Actuator Flange (20 required)	GC060906X02 GC060906X02	44	Diaphragm Plate (lower)	GC260113X02 GC260113X12
29	Hex-Head Machine Screw Type ACE95 (4 required)	1A3917X0062	45	Diaphragm Plate (lower)	GC260113X02 GC260113X12
30	Actuator Case (lower) Stainless steel Stainless steel NACE Steel	GC260105X02 GC260105X12 GC260105X32	46	Diaphragm Plate (lower)	GC260113X02 GC260113X12
31	Hex Nut (20 required)	1A3457K0012	47	Diaphragm Plate (lower)	GC260113X02 GC260113X12
32	Hex-Head Machine Screw (24 required)	GC060220X02	48	Diaphragm Plate (lower)	GC260113X02 GC260113X12

* Recommended Spare Part

1. FDA/USP Class VI approved/ADI-free elastomers (wetted parts only).

ACE95 Series

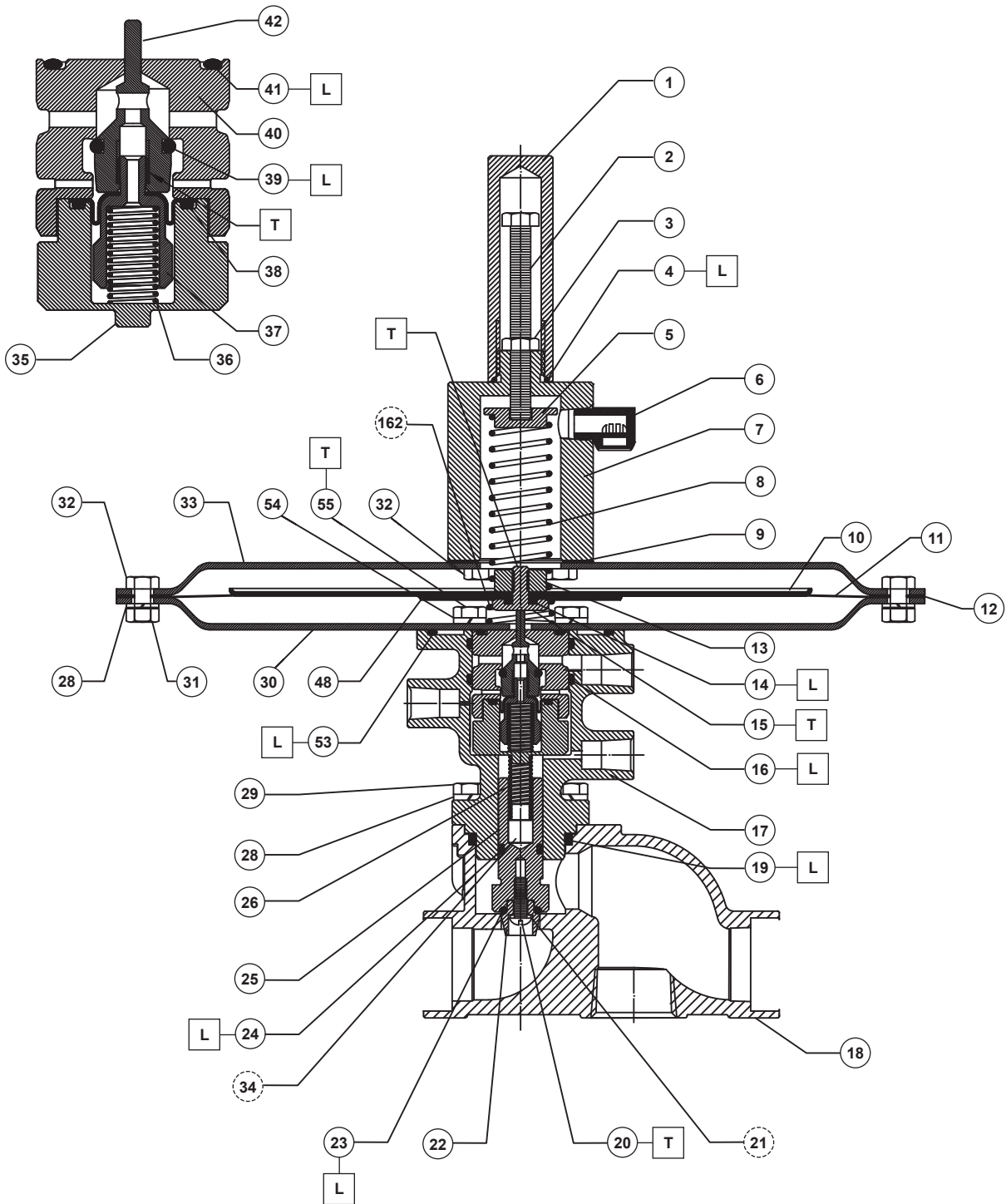

GE03297_AB

- NOT REQUIRED IN ALL ASSEMBLIES
- APPLY LUBRICANT OR THREAD LOCKER⁽¹⁾
- L = LUBRICANT
- T = THREAD LOCKER

1. Lubricant or thread locker must be selected such that they meet the temperature requirements.

Figure 8. Type ACE95 Tank Blanketing Valve

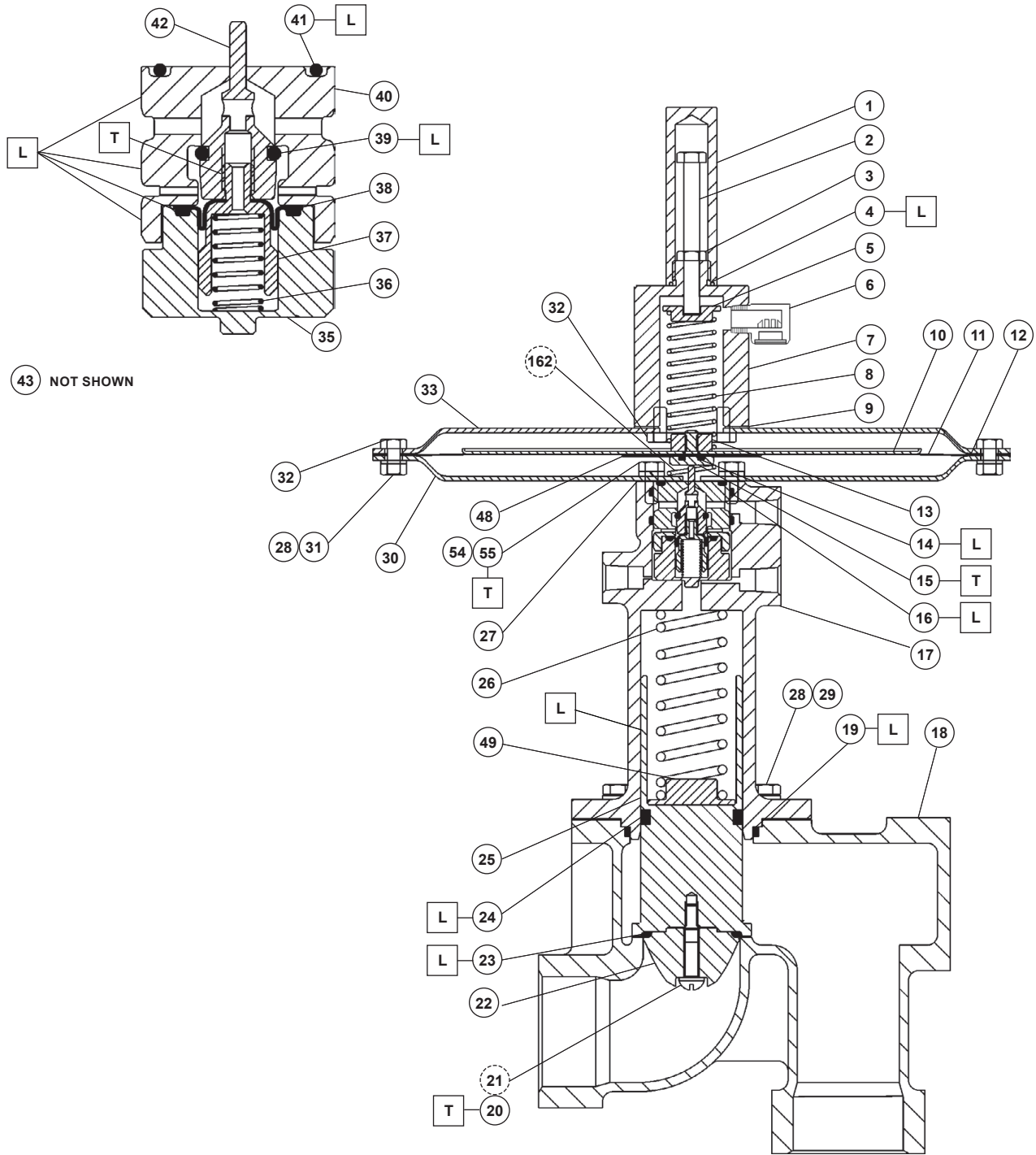

GC950801_CA

- NOT REQUIRED IN ALL ASSEMBLIES
- APPLY LUBRICANT OR THREAD LOCKER⁽¹⁾
- L = LUBRICANT
- T = THREAD LOCKER

1. Lubricant or thread locker must be selected such that they meet the temperature requirements.

Figure 9. Type ACE95Sr Tank Blanketing Valve

ACE95 Series

✉ Webadmin.Regulators@emerson.com

🔍 Fisher.com

📘 Facebook.com/EmersonAutomationSolutions

🌐 LinkedIn.com/company/emerson-automation-solutions

🐦 Twitter.com/emr_automation

Emerson Automation Solutions

Americas

McKinney, Texas 75070 USA
T +1 800 558 5853
+1 972 548 3574

Europe

Bologna 40013, Italy
T +39 051 419 0611

Asia Pacific

Singapore 128461, Singapore
T +65 6777 8211

Middle East and Africa

Dubai, United Arab Emirates
T +971 4 811 8100

D102775X012 © 2001, 2022 Emerson Process Management Regulator Technologies, Inc. All rights reserved. 11/22.

The Emerson logo is a trademark and service mark of Emerson Electric Co. All other marks are the property of their prospective owners. Fisher™ is a mark owned by Fisher Controls International LLC, a business of Emerson Automation Solutions.

The contents of this publication are presented for informational purposes only, and while every effort has been made to ensure their accuracy, they are not to be construed as warranties or guarantees, express or implied, regarding the products or services described herein or their use or applicability. All sales are governed by our terms and conditions, which are available upon request. We reserve the right to modify or improve the designs or specifications of such products at any time without notice.

Emerson Process Management Regulator Technologies, Inc. does not assume responsibility for the selection, use or maintenance of any product. Responsibility for proper selection, use and maintenance of any Emerson Process Management Regulator Technologies, Inc. product remains solely with the purchaser.

