

February 2019

Types C471, C477 and C486 Internal Valves



WARNING

Failure to follow these instructions or to properly install and maintain this equipment could result in an explosion and/or fire causing property damage and personal injury or death.

Fisher™ equipment must be installed, operated and maintained in accordance with federal, state and local codes and Emerson Process Management Regulator Technologies, Inc. (Emerson) instructions. The installation in most states must also comply with NFPA No. 58 and ANSI Standard K61.1.

Only personnel trained in the proper procedures, codes, standards and regulations of the LP-Gas industry should install and service this equipment.

The internal valve must be closed except during product transfer. A line break downstream of a pump may not actuate the excess flow valve. If any break occurs in the system or if the excess flow valve closes, the system should be shut down immediately.

Introduction

Scope of the Manual

This manual covers instructions for the Types C471, C477 and C486 internal valves.

Description

The valves are typically used on the inlets and outlets of bobtail and transport trucks and on large stationary storage tanks. They can also be installed in-line. Designed for propane, butane or Anhydrous Ammonia (NH₃) at ambient temperatures, the valves

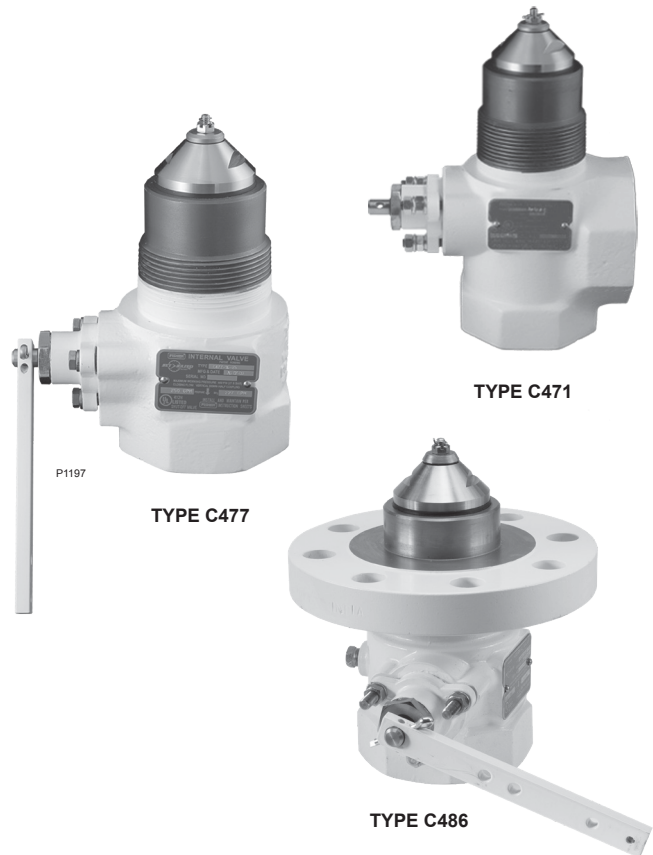

Figure 1. C471, C477 and C486 Series Internal Valves

can be used on other compressed gases, but the user should check with the factory to make sure the valves are suitable for the particular service.

DOT Internal Self-Closing Stop Valve Requirement—U.S. Department of Transportation (DOT) regulations 49CFR§178.337-8(a)(4) **require each liquid or vapor discharge outlet on cargo tanks (except for cargo tanks used to transport chlorine, carbon dioxide, refrigerated liquid and certain cargo tanks certified prior to January 1, 1995) to be fitted with an internal self-closing stop valve. Fisher “C” Series internal valves comply with the internal self-closing stop valve requirement under the DOT regulations.**

Types C471, C477 and C486

Specifications

The Specifications section on the following page shows specifications for Types C471, C477 and C486 internal valves.

Body Size and End Connection Styles

Types C471 and C477

Inlet: 2 or 3 in. MNPT / DN 50 or 80

Outlet: 2 or 3 in. FNPT / DN 50 or 80

Type C486

Inlet: 3 in. CL300 RF Flange / DN 80

Outlet: 3 in. FNPT / DN 80

Number of Outlets

Type C471: 2 (side and straight through)

Types C477 and C486: 1 (straight through)

Excess Flow Springs

Type C470 Half Coupling and Type C486 Flows:

2 in. / DN 50 Sizes: 105, 150 and 250 GPM /
397, 567 and 946 L/min

3 in. / DN 80 Sizes: 160, 265, 375 and 460 GPM /
605, 1003, 1419 and 1741 L/min

Type C470 Full Coupling Flows:

2 in. / DN 50 Sizes: 60, 80 and 130 GPM /
227, 302 and 492 L/min

3 in. / DN 80 Sizes: 120, 230, 320 and 380 GPM /
454, 870, 1211 and 1438 L/min

Maximum Allowable Inlet Pressure⁽¹⁾

400 psig / 27.6 bar WOG

Temperature Capabilities⁽¹⁾⁽²⁾

-20 to 150°F / -29 to 66°C

Approximate Weights

2 In. / DN 50 Sizes:

Type C471: 11 lbs / 5.0 kg

Type C477: 9 lbs / 4.1 kg

3 In. / DN 80 Sizes:

Type C471: 21 lbs / 10 kg

Type C477: 16 lbs / 7.3 kg

Type C486: 20 lbs / 9.1 kg

Construction Materials

Ductile Iron: Body (Types C471 and C477)

Stainless steel: Stem Assembly, Excess Flow Spring, Spring Seat, Closing Spring, Disc Holder, Disc Retainer, Screw, O-ring Seat, O-ring Retainer, Cotter Pin, Spring, Shaft, Screen, Travel Stop, Screen Cap, Bolt, Gasket and Lock Washer

Steel: Body (Type C486), Cap Screw and Operating Lever

Plated steel: Nut, Washer, Bonnet Nut, Guide Bracket and Cap Screw

Polyurethane (PU): Rod Wiper

Polytetrafluoroethylene (PTFE): Bushing, Packing Adaptor and Packing Ring

Nitrile (NBR) (Standard Construction): Main Disc, Bleed Disc and O-ring

Other Disc Material Available from Factory: Polytetrafluoroethylene (PTFE), Fluorocarbon (FKM), Neoprene (CR), Ethylene-Propylene (EPDM) and Kalrez®

1. The pressure/temperature limits in this Instruction Manual and any applicable standard or code limitation should not be exceeded.

2. Product has passed Fisher™ testing for leakage down to -40°F / -40°C.

Principle of Operation

Refer to the schematic drawing, Figure 2. In view #1, the valve is held closed by both tank pressure and the valve's closing spring. There is no leakage past the resilient seats in the poppet to the valve outlet.

The valve is opened by moving the operating lever to approximately mid-point in its 70° travel (view #2). This allows the cam to place the rapid equalization portion of the valve stem in the pilot opening, permitting a larger amount of product to bleed downstream than if the operating lever were moved to the full open position.

When tank and downstream pressure are nearly equal after a few seconds, the excess flow spring pushes open the main poppet (view #3) and the operating lever can be moved to the full open position.

If tank pressure is greater than the valve's outlet pressure, the main poppet will remain in the closed position. If valve outlet piping is closed off by other valves, however, product bleeding through the pilot will increase until it nearly equals tank pressure and the main poppet opens.

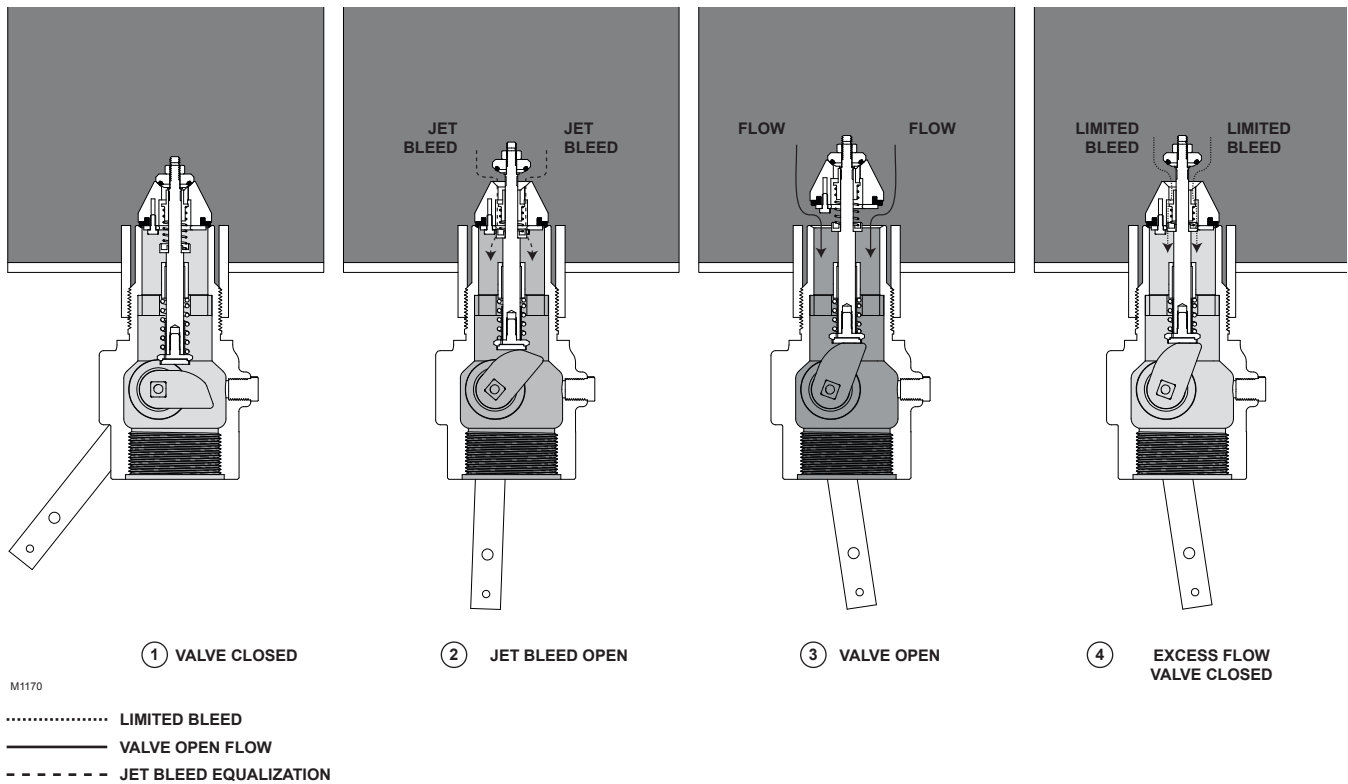

Figure 2. Operational Schematic

Note

The main poppet will not open if valve outlet piping is not closed off so that the outlet pressure can approach tank pressure.

Once the main poppet opens, a flow greater than the valve's excess flow spring rating or a sufficient surge in flow forces the main poppet closed against the excess flow spring (view #4). The pilot valve allows a small amount of product to bleed, but much less than view #2 where the rapid equalization portion of the stem is placed in the pilot opening. When the operating lever is moved to the closed position, the valve closes completely and seals tightly (view #1).

Installation

Mounting and Piping

The internal valves can be installed in either a half or full coupling. Excess flow spring closing flow rates vary in half and full couplings, refer to the Specification section.

CAUTION

Excess flow valve closing flow rates are not the same for half and full couplings. Verify the coupling for the desired excess flow rate.

Do not install the valve in any piping tending to restrict the valve inlet because this may prevent the excess flow valve from closing.

Do not install the valve with such extreme torque that the coupling can cut threads into the valve. This could cause valve distortion and affect the internal working parts.

Do not use PTFE tape as it may cause thread galling to occur.

Types C471, C477 and C486

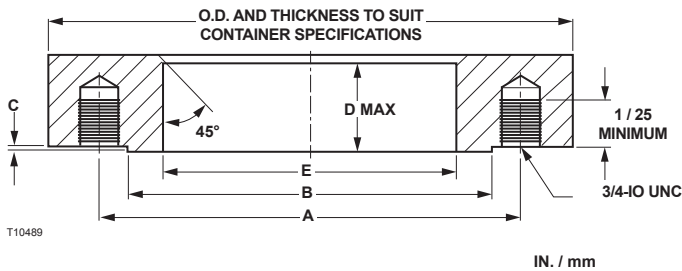

Figure 3. Tank Flange Dimensions

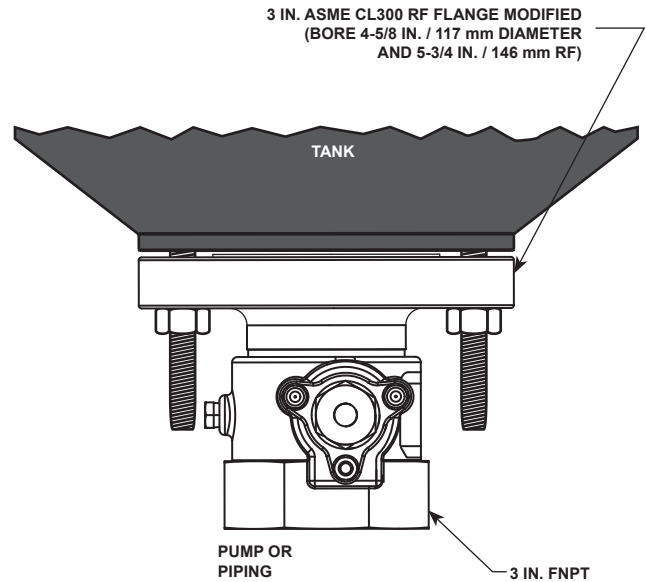

Figure 4. Valve Installation Schematic

Table 1. Tank Connections

MODIFIED CL300 ASME RF FLANGE	DIMENSION, IN. / mm							MATING FLANGE O.D., IN. / mm
	A			B RF	C RF	D	E (Modified) ⁽¹⁾	
	DBC	No.	Size					
3 in. / DN 80	6.62	8	0.75	5.75 / 146	0.06 / 1.5	1.50 / 38	4.62 / 117	8.25 / 210

1. Can be increased up to 4.81 in. / 122 mm for 3 in. valve, if valve and gasket are centered with modified flange opening.

For NPT connections, use an appropriate pipe compound, on the male threads of the internal valve and pipeline. Pull the valve into the coupling hand tight and then wrench tighten it for approximately two additional turns. Larger size valves may require an additional amount of torque to obtain a leak-free connection.

Keep piping from the valve outlet to the pump full size and as short as possible with a minimum number of bends. Reduction in pipe size to suit smaller pump inlets should be made as close to the pump as possible using forged reducers (swage nipples) or venturi tapers rather than bushings. This assures minimum flow resistance and efficient pump operation.

The valves have a break off section below the inlet pipe thread which is intended to permit the lower valve body to shear off in an accident, leaving the valve seat in the tank. **The break off section is designed for container installations and will probably not provide shear protection if the valve is installed in a pipeline.**

A hydrostatic relief valve does not need to be installed adjacent to the valve since the internal valve relieves excessive line pressure into the tank.

Type C486 Flange Installation

Lightly coat both sides of a spiral-wound, or other suitable, flange gasket with silicone grease or equivalent. An NPS 3 / DN 80, CL300 ASME RF flange with a modified bore (see Figure 3) must be installed in the tank. Special stud bolts, furnished with the valve, are assembled into this flange. The internal valve and flange gasket can then be installed as shown in Figure 4 with good flange bolting practices.

Selectively Filling Manifolded Tanks

Fisher™ internal valves provide positive shutoff only in one direction, from out of the tank to downstream of the valve. The internal valves are designed to allow gas to flow into a tank when the downstream line pressure exceeds tank pressure. If you want to selectively fill one or more of the other tanks in a tank manifold system, you must place a positive shutoff valve downstream of the internal valve, otherwise, all tanks will be filled at the same time and at about the same rate.

Actuators

The remote operating control system for the valve is extremely important and it must be installed to conform with the applicable codes. DOT MC331, for example, most generally applies for trucks.

Fisher offers both cable controls and pneumatic actuator systems to operate the C470 and C486 Series internal valves. It may also be possible to use cable controls from other manufacturers or to fabricate a linkage mechanism.

Any control system requires thermal protection (fuse links) at the valve, at the remote control point and, if necessary, near the hose connections. The Instruction Manuals for Emerson actuator systems show how to install the fuse links.

Installation instructions on Fisher Types P650, P163A and P164A cable controls, are in Document D450012T012. Pneumatic actuator installation is covered in Document D450162T012. Type P340 latch/remote release instructions are on Document D450123T012.

The operating linkage must allow the operating lever to move from the fully closed position to within 2° of the fully open position. The linkage should not apply strong force to the lever past the fully open position or the valve could be damaged.

Warranty Note

The use of non-Fisher actuators will void internal valve warranty and may result in leakage of the gland packing caused by premature wear. In addition to premature wear, the use of non-Fisher actuators may result in lower than expected flow rates and possible leakage across the valve seats.



CAUTION

The internal valve's closing spring is not designed to overcome drag in the control linkage in order to close the valve. Depending upon the control system used, an external spring (such as Fisher drawing number 1K4434) or positive closing linkage may be needed. Be sure the control system is installed to prevent binding that could cause the valve to stick in the open position.

Excess Flow Operation

The internal valve contains an excess flow function or "integral excess flow valve", that will close when the flow exceeds the flow rating established by Fisher. Fisher integral excess flow valve installed on a bobtail truck or transport can provide protection against the discharge of hazardous materials during an unloading operation of a bobtail truck or transport in the event that a pump or piping attached directly to the internal valve is sheared off before the first valve, pump or fitting downstream of the internal valve, provided that the cargo tank pressure produces a flow rate greater than the valve's excess flow rating.

Likewise, if the internal valve is installed on a stationary tank or in the related downstream piping system, the integral excess flow valve can provide protection against an unintentional release of hazardous materials in the event that a pump or piping attached directly to the internal valve is sheared off before the first valve, pump or fitting downstream of the internal valve, provided that the flow of product through the internal valve reaches the rated flow specified by Fisher.



EXPLOSION HAZARD

Restrictions incorporated in the discharge system of a bobtail truck or transport or of a stationary tank (due to pumps, pipe and hose length and dimensions, branching, elbows, reductions in pipe diameter or a number of other in-line valves or fittings), low operating pressure as a result of ambient temperature or a partially closed valve downstream from the integral excess flow valve, can restrict the rate of flow through the internal valve below the level necessary to actuate the integral excess flow valve. Therefore, **DO NOT USE** the excess flow function of the internal valve for the purpose of providing protection against the discharge of hazardous materials in the event of a rupture of hose or piping at a point in the discharge system downstream from the first valve, pump or fitting downstream of the internal valve.

The internal valve is designed with an internal bleed feature for equalization of pressure. After the integral excess flow valve closes, the leakage through the bleed must be controlled or a hazard can be created. For this reason the operator must be familiar with the closure controls for the internal valve and must close the internal valve immediately after the integral excess flow valve closes.

Failure to follow this warning could result in serious personal injury or property damage from a fire or explosion.

DOT Passive Shutdown Equipment Requirement— DOT regulations 49CFR§173.315(n)(2) require certain cargo tanks transporting propane, anhydrous ammonia and other liquefied compressed gases to be equipped with passive emergency discharge control equipment that will automatically shutoff the flow of product without human intervention within 20 seconds of an unintentional release caused by complete separation of a delivery hose. The design for each passive shutdown system must be certified by a Design Certifying Engineer (DCE) and all components of the discharge system that are integral to the design must be included in the DCE certification. The DCE certification must consider any specifications of the original component manufacturer.

In the case of downstream ruptures in hose or piping, a variety of operating conditions routinely encountered during an unloading operation restrict the rate of flow through the integral excess flow valve and make such a valve unsuitable to serve as the means of passive shutdown required under 49CFR§173.315(n)(2). Such variables include restrictions incorporated in the discharge system (due to pumps, pipe and hose length and dimensions, branching, elbows, reductions in pipe diameter or a number of other in-line valves or fittings), low operating pressure as a result of ambient temperature or a partially closed valve downstream from the excess flow valve. Due to the variety of conditions, in the case of a hose separation, that can restrict the rate of flow below the level necessary to activate the excess flow valve, the integral excess flow function of Fisher™ “C” Series internal valves or “F” Series excess flow valves cannot be used to satisfy the passive shutdown equipment requirement under/in 49CFR§173.315(n)(2). Also, a Design Certifying Engineer cannot include the integral excess flow valve of a Fisher “C” Series internal valve or “F” Series excess flow valve as a component of the discharge system in any DCE certification under 49CFR§173.315(n)(2).



EXPLOSION HAZARD

DO NOT USE the excess flow function incorporated into Fisher “C” Series internal valves or “F” Series excess flow valves to satisfy the passive shutdown equipment requirement in 49CFR§173.315(n)(2). **DO NOT** include the excess flow function incorporated into Fisher “C” Series internal valves or “F” Series excess flow valves in a DCE certification under 49CFR§173.315(n)(2). The cargo tank manufacturer must install some other equipment that satisfies the requirement for passive shutdown capability under 49CFR§173.315(n)(2).

Failure to follow this warning could result in serious personal injury or property damage from a fire or explosion in the event of an unintentional release of product during an unloading operation.

Operation

Since the C470 and C486 Series will not open unless the downstream pressure can build-up to equal the inlet pressure, an operating sequence that assures equalization is important.

Follow these points:

1. C470 and C486 Series on bobtails and transports should never be open when the truck is in motion. If the control system is not interlocked to prevent this, the operator is responsible to see that the valves are closed.
2. Always open the internal valve before opening any other valves in the line or starting the pump.
3. Move the lever to the half-open position (Operational Schematic, view #2) to equalize pressure. When the main poppet clicks open, move the operating lever fully open.
4. Open other line valves slowly to avoid sudden surges which could slug the excess flow valve shut.
5. If the excess flow valve does close, stop the pump and close the nearest downstream valve. Move the internal valve's operating lever back to the rapid equalizing position and wait for the valve to click open. Then move the operating lever fully open and slowly open the downstream valve.
6. All valves should be completely open when pumping. (Throttling type valves could prevent the excess flow valve from closing when required.)
7. The operator must always be aware of where the remote closure controls are located and know how to operate the controls if an emergency requires valve closure. When pumping is finished, make a habit of closing the internal valve from the remote closure point, thus checking to see that the control actually is capable of closing the valve.
8. The valve should be open when backfilling through the valve to fill the tank.

Troubleshooting

Internal Valve Will Not Open—This could be due to leakage downstream, engaging the pump too soon or from excessive wear in the internal valve. If excessive volume is in the downstream system, a longer time is required to equalize the pressures (tank and downstream) before the pump can be engaged. To determine if the valve pilot seat is opening, install a gauge downstream of the valve, operate the valve actuator; if pressure does not build up to the tank pressure, the valve pilot seat is not open. This test should be done with pump off. If the pilot is not opening, it may be plugged with dirt or some internal part may be broken. If by operating the lever manually it can be rotated past the fully open position, there is something wrong internally and the valve must be disassembled.

Premature Valve Closure—This can be caused from engaging the pump too soon, by an underrated excess flow valve spring or by an improperly connected internal valve operating lever which does not fully open the valve. The trouble could also be from a valve that has its inlet port obstructed or from sudden line surges. In order to check the valve opening travel, operate the lever manually to the full travel, wait until valve opens, then engage the pump. If the excess flow closes, the points mentioned above should be investigated.

Internal Valve Will Not Close—The stub shaft could be binding or the stem could be bent in the valve. Before disassembling the valve, check the actuator mechanism to see that it operates freely by disconnecting it from the valve lever and cycling it several times. Also, operate the valve lever manually. If it sticks in the open position, the packing and bushings should be replaced. This should free the operating mechanism if the valve has not been damaged internally. Refer to the "Maintenance" section.

Low Flow Capacity—This could be caused by too small an internal valve, too small or long downstream piping, plugged screens, some other restriction in the downstream system or by the bypass valve sticking in the open position. The bypass valve could also be set too low and be opening prematurely.

Types C471, C477 and C486

Maintenance

CAUTION

Do not use these internal valves if they leak, fail to work properly or have been damaged or have missing parts. Prompt repairs should be made by a properly trained service person. Continued use without repair can create a hazardous or injurious situation.

A simple preventative maintenance program for the valve and its controls will eliminate a lot of potential problems.

Fisher™ recommends these steps be conducted once a month. Also refer to the Department of Transportation (DOT) CFR 49 Sections 180.416 and 180 Appendix A and B which specify monthly maintenance and inspections tests for cargo tank service internal valves and their actuation controls.

1. Inspect the operating lever to see that it operates freely and that there is no leakage around the retainer nut. If there is sticking or leakage, replace the packing and bushings. Refer to Replacing Packing.
2. Check for tight closure of the seat discs. Any detected leakage, which is normally caused by disc wear or dirt, scale or debris embedded in the disc, requires that the internal valve be removed from service and repaired. Repair most often requires the replacement of valve discs. To check for leakage:
 - a. Close the internal valve and exhaust downstream pressure. Close the first valve downstream from the internal valve and note any pressure buildup, using a pressure gauge, between the closed valve and the internal valve. If piping is cold allow it to warm to ambient temperature.
 - b. Refer to CFR 49 Section 180 Appendix B for Meter Creep Test Methods.
3. All operating controls should be inspected and cleaned and oiled. The controls should be checked to see that they fully open—but not over-travel—the internal valve operating lever and operate freely to close the valve.



Figure 5. Use Tool Provided or Spring Seat (key 4) and Stem Assembly (key 2) to Align Disc Retainer (key 8)

4. Standard construction internal valves must be removed if the container is to be steam cleaned. Heat can damage the valve's seats and seals.
5. Standard construction internal valves are not designed for water service. Immediately after a container is hydrostatically tested, remove all water and allow the container to thoroughly dry out.

Disassembly

WARNING

Tank pressure must be released before removing the valve from the container. Failure to do so could result in personal injury.

Numbers in parenthesis refer to key numbers in Figures 5 to 9.

Types C471, C477 and C486

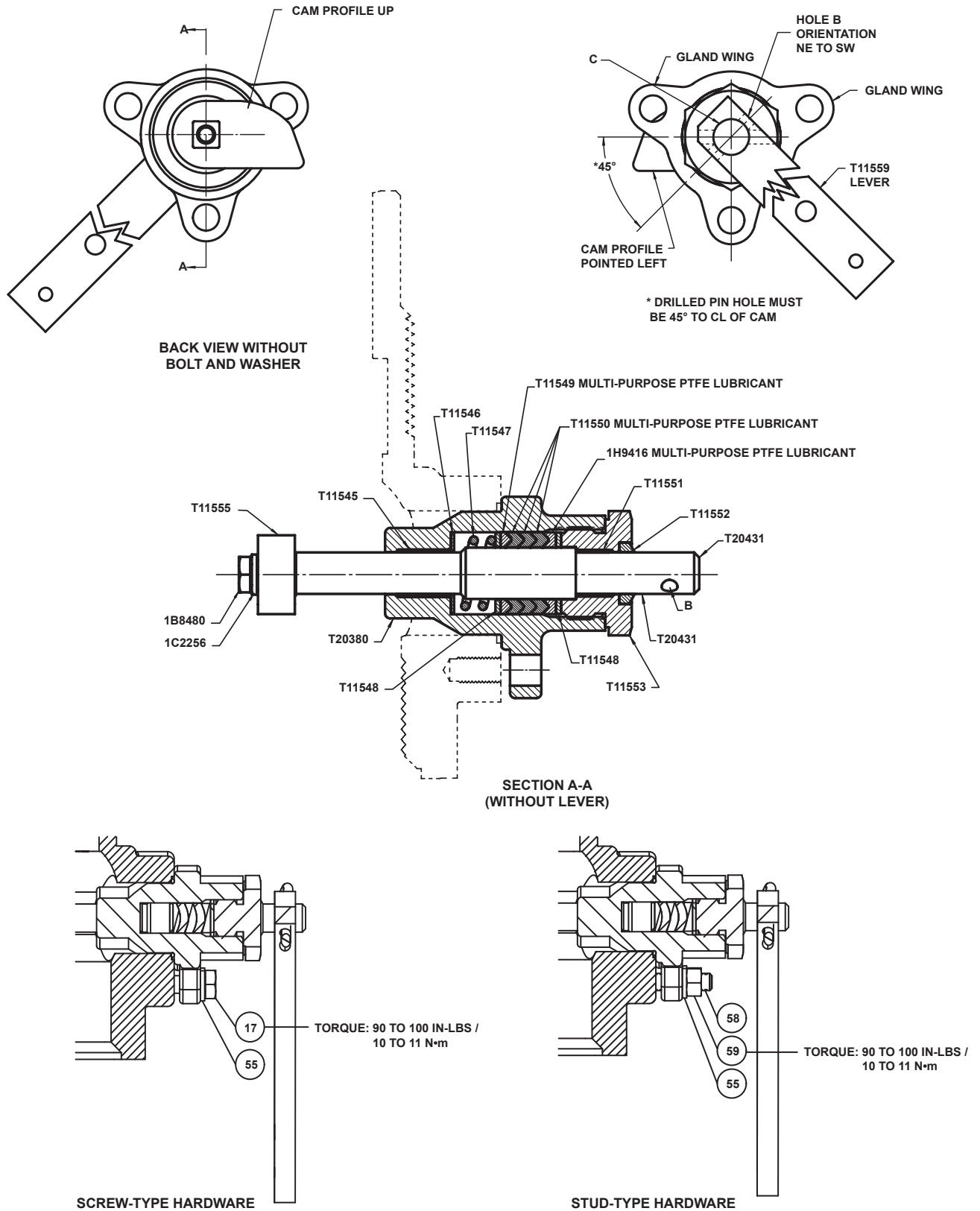

Figure 6. Stub Shaft Orientation

Types C471, C477 and C486

To Replace Packing or Install Gland Hardware



WARNING

Downstream pressure must be released before removing the screws holding the gland assembly to the internal valve body. Failure to do so could result in personal injury.

1. The packing (keys 15F, G and H) can be replaced with product in the tank by closing the operating lever (key 18) and blowing down the downstream pressure in the system.
2. If using Screw-Type hardware, remove the three cap screws (key 17) holding the bonnet assembly to the body. If using the current Stud-Type hardware, remove the nuts (key 59) and washers (key 55) holding the bonnet assembly to the body.

Note

If working on a valve equipped with a pneumatic actuator, please refer to the corresponding actuator Instruction Manual for proper removal procedures.

3. Rotate the entire bonnet assembly slightly to remove it from the body.
4. Unscrew the cap screw (key 15R) from the stub shaft (key 15J) and remove the operating lever by taking out the cotter pin (key 19).
5. Unscrew the retaining nut (key 15M) from the bonnet. Pushing on the stub shaft (key 15J) will expose the bonnet parts including the packing.
6. Besides the packing, the liner bushings (keys 15B and 15K) should be replaced. Lubricate the packings with Multi-purpose PTFE lubricant.
7. Reassemble in reverse order. Replace cap screw (key 15R) using 30 to 35 in-lbs / 3.4 to 4.0 N•m torque.
8. Before replacing the gland assembly, replace the O-ring (key 16) with the proper material matching the main seals. The standard Types C471 and C477 material is Nitrile (NBR).
9. Orient Cam and stub shaft (See Figure 6)

Before reassembling the gland assembly into the body, make sure the operating lever can move freely

with the new parts installed. Then, correctly orient the cam to the stub shaft. Incorrect orientation will result in either:

- a. Not being able to open the internal valve or
- b. Only being able to partially open the internal valve which will cause the valve's excess flow feature to close prematurely

Refer to Figure 6. Looking at the end of the stub shaft (C) that the lever or actuator attaches to:

- a. The cam profile on the opposite end of the shaft should be up and the cam pointing to the left.
 - b. The hole (B) through the stub shaft that the lever/ actuator attaches to should be oriented in a NE to SW position with N being at the top.
 - c. The 2 gland wings should be at the top as shown in Figure 6.
 - d. The lever should be oriented as shown and the cotter pin run through hole (B).
10. Once proper orientation of the cam is confirmed:
 - a. Reinstall the washers (key 55) and nuts (key 59) and torque to 90 to 100 in-lbs / 10 to 11 N•m. Reinstall actuator or latch if applicable.
 - b. If reusing the cap screws, reinstall the actuator or latch if applicable before installing the cap screws and washers. Torque to 90 to 100 in-lbs / 10 to 11 N•m.
 - c. If installing new studs, install the long studs (key 57) in the top-most hole locations and the short stud (key 58) in the bottom-most location. Secure the gland to the body with the first set of washers (key 12) and nuts. Reinstall actuator or latch if applicable or cover two long studs with protective cap (key 60) if available.

To Replace Seat Discs

1. Remove the valve from the tank.
2. Remove the cotter pin (key 14, Figure 7) and unscrew the hex nut (key 13).
3. Remove both disc holders (keys 6 and 12) from the stem (key 2).
4. Unscrew the screws (keys 9 and 4 for 2 in. / DN 50, 6 for 3 in. / DN 80) holding the disc retainer (key 8) to replace the main seat disc.
5. Examine both seat discs (keys 7 and 11) and replace if necessary.
6. If the excess flow spring (key 3) is changed, replace the nameplate or stamp the body with the new type number.

Types C471, C477 and C486

7. Always replace the sealing washer (key 23), with a new sealing washer and follow recommended torque values for hex nut, (key 13).
8. a. Reassemble in reverse order. Tighten the screws (key 9) using 20 in-lbs / 2.2 N•m torque to install the disc retainer (key 8) properly.



CAUTION

Failure to properly center the disc retainer to the disc holder may result in improper function of the valve.

Important

During replacement of the seat disc, use P/N GE45079X012 provided to center the disc retainer to the disc holder (See Figure 5). Line up holes and insert screws. Keep the alignment tool inserted until all of the screws are tightened to specification.

Alternately, the stem assembly (key 2) and spring seat (key 4) may be used as shown in Figure 5 to perform this alignment. After assembly, check to make sure there is no interference of the spring seat and disc retainer when the valve is in the excess flow position.

- b. Apply Medium-Strength Threadlocker on the stem threads before installing the hex nut (key 13).

Parts Ordering

Important

Use only genuine Fisher™ replacement parts. Components that are not supplied by Emerson should not, under any circumstances, be used in any Fisher valve, because they will void your warranty, might adversely affect the performance of the valve and could give rise to personal injury and property damage.

When corresponding about this equipment, always reference the equipment type number found on the nameplate.

When ordering replacement parts, reference the complete 11-character part number for each needed part.

Parts List

Types C471, C477 and C486 Internal Valves

Key	Description	Part Number
	Repair Kit	
	2 in. NPT / DN 50	RC47016T012
	3 in. NPT / DN 80	RC47024T012
1	Body	
	Type C471, Ductile Iron	
	2 in. / DN 50	T40195T0012
	3 in. / DN 80	T80119T0012
	Type C477, Ductile Iron	
	2 in. / DN 50	T40132T0012
	3 in. / DN 80	T80089T0012
	Type C486	
	3 in. / DN 80 Flange by FNPT	ERAA00979A0
2	Stem Assembly	
	†2 in. / DN 50, Steel/Stainless steel	GE41520T012
	*3 in. / DN 80, Steel	GE41522T012
2A	Stem	
	2 in. / DN 50, Steel/Stainless steel	GE35309T012
	3 in. / DN 80, Steel	GE35311T012
2B	Follower Assembly, Steel/Stainless steel	T1188000A2
2C	Groove Pin, Steel/Stainless steel	IJ1560T0012
3	Excess Flow Spring, Stainless steel	
	2 in. / DN 50	
	105 GPM / 397 L/min, Green	GE42498X012
	150 GPM / 567 L/min, Yellow	T1153537022
	250 GPM / 946 L/min, Pink	T1200537022
	3 in. / DN 80	
	160 GPM / 605 L/min, Blue	GE42499X012
	265 GPM / 1003 L/min, Black	GE42500X012
	375 GPM / 1419 L/min, Yellow	GE42851X012
	460 GPM / 1741 L/min, Red	GE42501X012
4	Spring Seat, Stainless steel	
	2 in. / DN 50	GE35317T012
	3 in. / DN 80	GE35318T012
5	Closing Spring, Stainless steel	T1153737022
6	Disc Holder, Stainless steel	
	2 in. / DN 50	GE35315T012
	3 in. / DN 80	GE35316T012

† Recommended spare part for 2 in. / DN 50 body size.

* Recommended spare part for 3 in. / DN 80 body size.

Kalrez® is a mark owned by E.I. du Pont de Nemours and Co.

Types C471, C477 and C486

Key	Description	Part Number	Key	Description	Part Number
7	Main Disc †2 in. / DN 50 Nitrile (NBR) PTFE Fluorocarbon (FKM) Neoprene (CR) Kalrez® Ethylene Propylene (EPDM) *3 in. / DN 80 Neoprene (CR) Nitrile (NBR) PTFE Fluorocarbon (FKM) Kalrez® Ethylene Propylene (EPDM)	T1154003202 T1214006242 T12533T0012 T12879T0012 T12877T0012 T13474T0012 T12914T0012 T1177403032 T1217306242 T12535T0012 T12921T0012 T13476T0012	15J	Stub Shaft 2 in. / DN 50, Stainless steel 3 in. / DN 80, Stainless steel	T2037835072 T2043135072
8	Disc Retainer 2 in. / DN 50, Steel/Stainless steel 3 in. / DN 80, Steel	GE35313T012 GE35314T012	15K†*	Liner Bushing, PTFE	T1155106992
9	Screw 2 in. / DN 50, Steel/Stainless steel (4 required) 3 in. / DN 80, Steel (6 required)	13B3513X022 13B3513X022	15L†*	Rod Wiper, Polyurethane (PU)	T1155206992
10	Bleed Disc seat, Steel/Stainless steel	ERAA00325A0	15M	Bonnet Nut, Steel	T1155324102
11†*	Bleed Disc Nitrile (NBR) PTFE Fluorocarbon (FKM) Kalrez® Neoprene (CR) Ethylene Propylene (EPDM)	ERAA00328A0 ERAA00328A1 ERAA00328A2 ERAA00328A3 ERAA00328A4 ERAA02202A0	15P	Cam Steel Stainless steel	T1155521992 T1220535072
12	Bleed Disc Retainer, Stainless steel	ERAA00324A0	15R	Cap Screw Steel Stainless steel	1B848024052 T12206T0022
13†*	Hex Nut, Plated steel	GE04678T012	15S	Washer Steel Stainless steel	1C225628982 T1220736152
14†*	Cotter Pin, Stainless steel	T1241338992	16†*	O-ring Nitrile (NBR) PTFE Fluorocarbon (FKM) Kalrez® Neoprene (CR) Ethylene Propylene (EPDM)	T1155706562 T1214206522 T12577T0012 T1214206522 T1214206522 T13477T0012
15	Gland Assembly, Nitrile (NBR) 2 in. / DN 50 3 in. / DN 80	T20377000B2 T20430000B2	17	Cap screw, Steel (3 required)	T12499T0012
15A	Gland Steel Stainless steel	T2038022012 T2052033092	18	Operating Lever, Steel	T1155919312
15B†*	Liner Bushing, PTFE	T1154506992	19†*	Cotter pin, Carbon-plated Steel (not shown)	1H837128982
15C†*	Washer Steel Stainless steel	T1154625072 T1220236152	20	Nameplate (not shown)	-----
15D	Spring, Stainless steel	T1154737022	21	Drive Screw, Stainless steel (2 required) (not shown)	1A368228982
15E†*	Washer (2 required) Steel Stainless steel	T1154825072 T1220336152	22	Pipe plug, Zinc (not shown)	T13718T0012
15F†*	Male Packing Adaptor, PTFE	T1154901012	23†*	Washer Steel Stainless steel	T1188228982 T11882T0012
15G†*	Packing, PTFE (3 required)	T1155001012	30	Fusible Link (not shown)	1J157443992
15H†*	Female Packing Adaptor, PTFE	1H941601012	33	Travel stop, Stainless steel	T1240838072
			35†*	Bushing, PTFE	T1221306992
			36	Guide, Iron Type C471 2 in. / DN 50 3 in. / DN 80 Type C477 2 in. / DN 50 3 in. / DN 80	T12918T0012 T12511T0012 T12918T0022 T12511T0012
			55	Lock washer, Stainless steel (3 required)	1C2257K0012
			57	Stud, Long (2 required)	ERAA02623A0
			58	Stud, Short	ERAA02652A0
			59	Nut	1A309338992
			60	Thread Cap (2 required) (not shown)	ERAA02691A0

† Recommended spare part for 2 in. / DN 50 body size.
* Recommended spare part for 3 in. / DN 80 body size.
Kalrez® is a mark owned by E.I. du Pont de Nemours and Co.

Types C471, C477 and C486

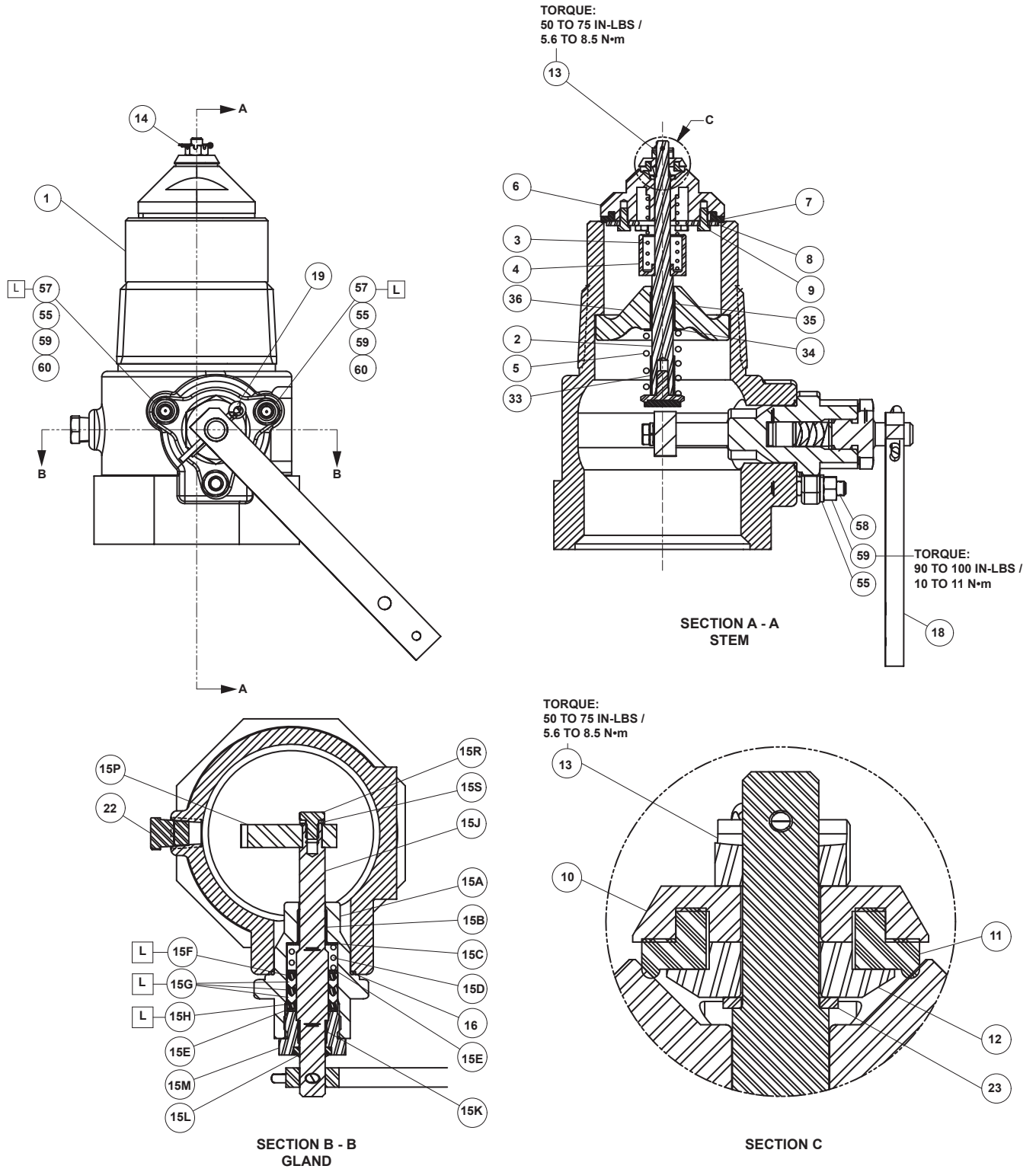

□ APPLY LUBRICANT⁽¹⁾
L = MULTI-PURPOSE PTFE LUBRICANT

1. Lubricants must be selected such that they meet the temperature requirements.

Figure 7. Type C477 Assemblies

Types C471, C477 and C486

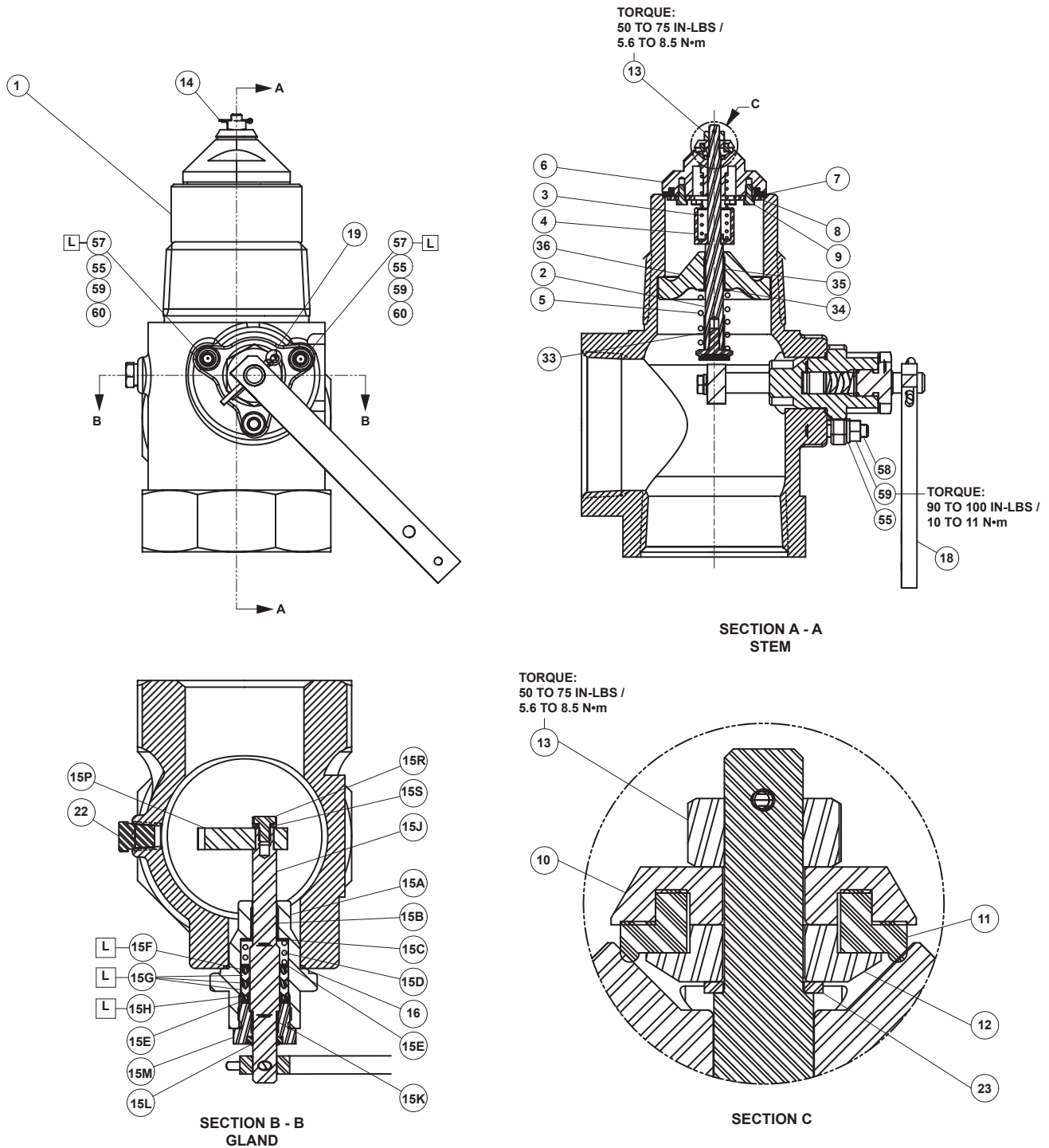

PARTS NOT SHOWN: 20 AND 21

APPLY LUBRICANT⁽¹⁾
L = MULTI-PURPOSE PTFE LUBRICANT

1. Lubricants must be selected such that they meet the temperature requirements.

Figure 8. Type C471 Assemblies

Types C471, C477 and C486

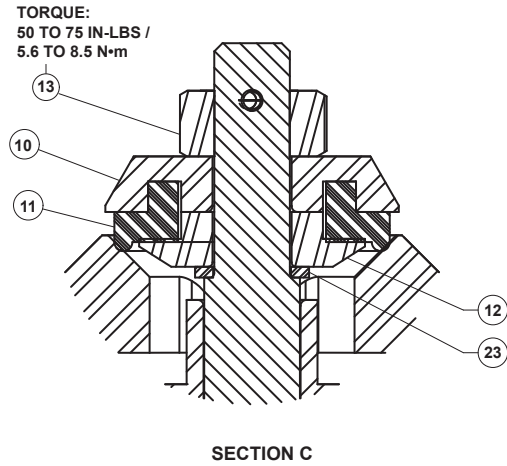
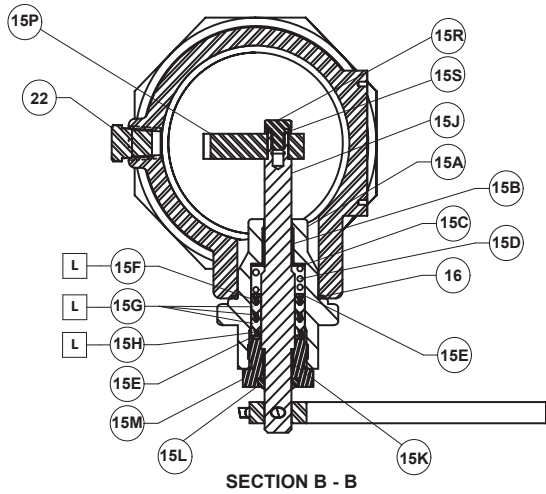
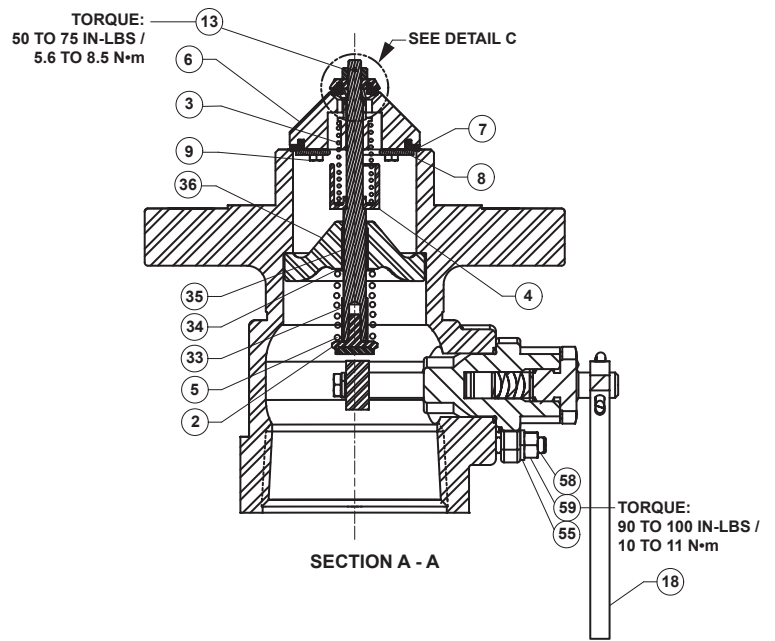
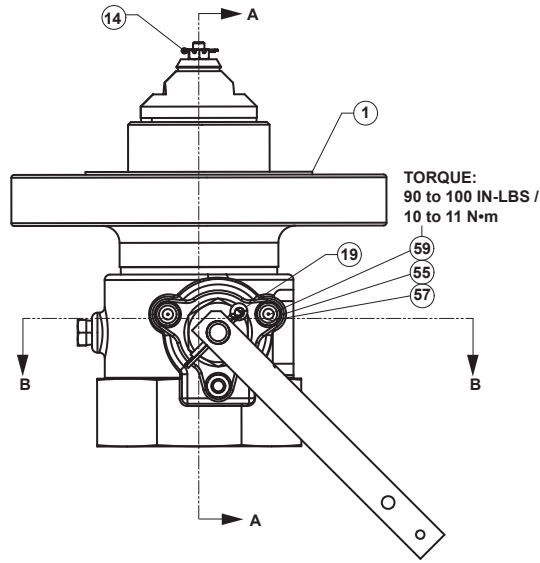

PARTS NOT SHOWN: 20 AND 21

APPLY LUBRICANT⁽¹⁾

L = MULTI-PURPOSE PTFE LUBRICANT

1. Lubricants must be selected such that they meet the temperature requirements.

Figure 9. Type C486 Assemblies

Types C471, C477 and C486

 Webadmin.Regulators@emerson.com

 Fisher.com

 Facebook.com/EmersonAutomationSolutions

 LinkedIn.com/company/emerson-automation-solutions

 Twitter.com/emr_automation

Emerson Automation Solutions

Americas

McKinney, Texas 75070 USA
T +1 800 558 5853
+1 972 548 3574

Europe

Bologna 40013, Italy
T +39 051 419 0611

Asia Pacific

Singapore 128461, Singapore
T +65 6777 8211

Middle East and Africa

Dubai, United Arab Emirates
T +971 4 811 8100

D450229T012 © 2002, 2019 Emerson Process Management Regulator Technologies, Inc. All rights reserved. 02/19.

The Emerson logo is a trademark and service mark of Emerson Electric Co. All other marks are the property of their prospective owners. Fisher™ is a mark owned by Fisher Controls International LLC, a business of Emerson Automation Solutions.

The contents of this publication are presented for information purposes only, and while effort has been made to ensure their accuracy, they are not to be construed as warranties or guarantees, express or implied, regarding the products or services described herein or their use or applicability. All sales are governed by our terms and conditions, which are available on request. We reserve the right to modify or improve the designs or specifications of our products at any time without notice.

Emerson Process Management Regulator Technologies, Inc does not assume responsibility for the selection, use or maintenance of any product. Responsibility for proper selection, use and maintenance of any Emerson Process Management Regulator Technologies, Inc. product remains solely with the purchaser.

