

April 2009

Type M570 Filler Hose Adaptor

WARNING

Failure to follow these instructions or to properly install and maintain this equipment could result in an explosion and/or fire causing property damage and personal injury or death.

Fisher® equipment must be installed, operated, and maintained in accordance with federal, state, and local codes, and manufacturer's instructions. The installation in most states, must comply with NFPA 58 standards.

Only personnel trained in the proper procedures, codes, standards, and regulations of the LP-Gas industry should install and service this equipment.



Figure 1. Type M570 Hose Adaptor

Operation

WARNING

Failure to properly engage the ACME threads on either end of the Type M570 can result in leakage or an accidental disconnect which could result in liquid propane escaping to the atmosphere. Proper engagement of a Type M570 ACME thread joint should be in excess of 1 full turn.

Do not use the Type M570 if the black spacer is damaged or missing on the male ACME end of the coupling. Such unauthorized use will result in an improper ACME thread engagement between the Type M570 and the tank filler valve.

Introduction

Scope of the Manual

This manual provides operating, maintenance, and parts information on Type M570 filler hose adaptor.

Description

The Type M570 is a 1-3/4-inch male ACME by 1-3/4-inch female ACME adaptor with a built-in back check valve for use with the Fisher Type N480 hose end valve or hose end valves made by other manufacturers. Maximum inlet pressure is 400 psi (27,6 bar).



Type M570

Type M570 attaches to the outlet of a hose end valve. The adaptor permits removal of the hose end valve from filler valves that fail to close.

In normal operation, the trapped volume of LP-Gas liquid will quickly bleed off (30 seconds or less) once the Type M570 connection to the filler valve has been loosened. The Type M570 and attached hose end valve can then be removed.

CAUTION

Bleeding of trapped LP-Gas can freeze burn unprotected skin.

If the vapor/liquid bleed continues, retighten the Type M570 to the filler valve, and quickly open and close the hose end valve or tap the sides of the hose end valve to seat the check in the filler valve. If the bleed persists when the Type M570 filler valve connection is loosened, again retighten the adaptor.

Loosen the hose end valve slightly from the Type M570, again tighten the Type M570 to the filler valve, and wait for any bleed to stop (not over 30 seconds). The adaptor should be left on the filler valve only until the filler valve can be repaired or replaced. Do not leave a back check adaptor like the Type M570 permanently on a filler valve.

If pressure does not bleed off between the hose end valve and the Type M570, there is still a problem. Do not attempt to disconnect until the problem is corrected and the filler valve and/or Type M570 seat tightly. Again try quickly opening and closing the hose end valve or tapping the sides of the valves to seat the checks.

The Type M570 has the following restrictions:

1. Use Type M570 on a tank only until the tank can be emptied and repair or replacement of the filler valve can be made.
2. Do not stack Type M570s on a filler valve.
3. The Type M570 is the only filler hose adaptor that should be used with Fisher® Type N480 hose end valves. Any other style of adaptor will permit the accidental opening of the Type N480.

Maintenance

CAUTION

Do not use a Type M570 that leaks, fails to work properly, or that has damage or missing parts. Prompt repairs should be made by a properly trained service person because a malfunctioning Type M570 can create a hazard, such as an explosion, fire, freeze burns, asphyxiation, or the uncontrolled release of propane gas.

If the Type M570 cannot be properly repaired, it should be replaced immediately.

Both the upper rubber gasket (key 5, Figure 2) and lower gasket seat (key 13) are subject to wear and/or damage. These surfaces should be kept free of obstructions, gouges, and large nicks. Such conditions can cause leakage out of the Type M570 filler valve connection, the hose end valve Type M570 connection, or possibly leakage out of the Type N480 coupler.

Leakage at the Type M570 and hose end valve joint or at the top of the ribbed swivel on the hose end valve may result from excessive wear in the hose end valve. Excessive wear in the hose end valve will not let the hose end valve ACME seating surface contact the rubber gasket in the Type M570 before the ACME end of the ribbed swivel contact the spacer on the Type M570.

To replace the upper gasket (key 5), simply slip it into the gasket retainer (key 2). Replace this gasket only with the part number shown.

CAUTION

Do not use any other gasket because it could cause the Type M570 to leak or jam.

The gasket seat (key 13) can be replaced by extending the inner body (key 2), holding it with a pair of pliers, and unscrewing the gasket seat with a hex wrench. Apply Loctite No. 242 to the male threads of the gasket seat and screw it into the inner body using 10 to 20 foot-pounds (14 to 27 N•m) torque.

To replace the gasket (key 5), unthread the old gasket off the male ACME thread and screw on the new spacer.

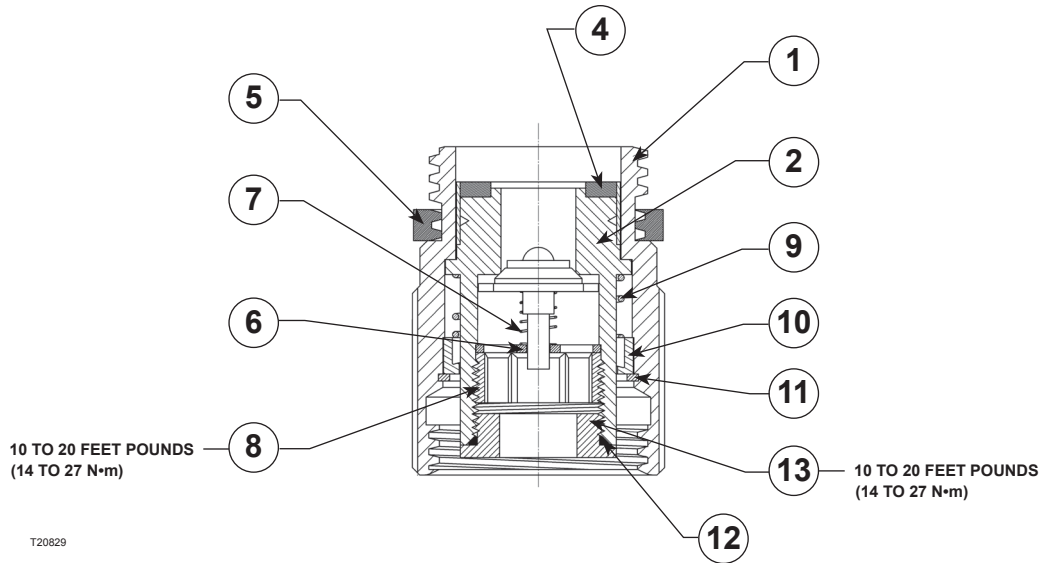

Figure 2. Type M570 Hose Adaptor Assembly

Parts List

Key	Description	Part Number	Key	Description	Part Number
1	Adaptor Body, Brass	T20826T0012	8	Spring Retainer Nut, Brass	T20754T0012
2	Body/Gasket Retainer Assembly	T20827T0012	9	Spring, 302 Stainless steel	T13287T0012
3	Stem/Disk Assembly, Brass/Nitrile (NBR)	T13097T0012	10	Spring Seat, Brass	T13288T0012
4	Washer, Nitrile (NBR)	T13103T0012	11	Retaining Ring, Stainless steel	T13286T0012
5	Gasket, Nylon (PA)	T13098T0012	12	O-ring, Nitrile (NBR)	T1224006562
6	Spring Retainer, 18-8 Stainless steel	T13106T0012	13	Gasket Seat, 416 Stainless steel	T20825T0012
7	Back Check Spring, 302 Stainless steel	T13100T0012			

Type M570

LP-Gas Equipment

Emerson Process Management Regulator Technologies, Inc.

USA - Headquarters
McKinney, Texas 75070 USA
Tel: 1-800-558-5853
Outside U.S. 1-972-548-3574

For further information visit www.emersonprocess.com/regulators/lp

The Emerson logo is a trademark and service mark of Emerson Electric Co. All other marks are the property of their prospective owners. Fisher is a mark owned by Fisher Controls, Inc., a business of Emerson Process Management.

The contents of this publication are presented for informational purposes only, and while every effort has been made to ensure their accuracy, they are not to be construed as warranties or guarantees, express or implied, regarding the products or services described herein or their use or applicability. We reserve the right to modify or improve the designs or specifications of such products at any time without notice.

Emerson Process Management does not assume responsibility for the selection, use or maintenance of any product. Responsibility for proper selection, use and maintenance of any Emerson Process Management product remains solely with the purchaser.