

July 2014

Type P539 Pneumatic Actuator with Type P539A Hardware Retrofit Kit

WARNING

Failure to follow these instructions or to properly install and maintain this equipment could result in an explosion and/or fire causing property damage and personal injury or death.

Fisher® equipment must be installed, operated and maintained in accordance with federal, state and local codes and Emerson Process Management Regulator Technologies, Inc. instructions. The installation in most states must also comply with NFPA No. 58, ANSI K61.1 and DOT standards.

Only personnel trained in the proper procedures, codes, standards and regulations of the LP-Gas or Anhydrous Ammonia (NH₃) industries should install and service this equipment.

Introduction

This product kit manual provides instructions for easy upgrade of Type P539 pneumatic actuator to a Type P539A actuator with minimum parts and the re-use of air chamber and clevis from the Type P539.

CAUTION

Only qualified service person should attempt to repair these valves.

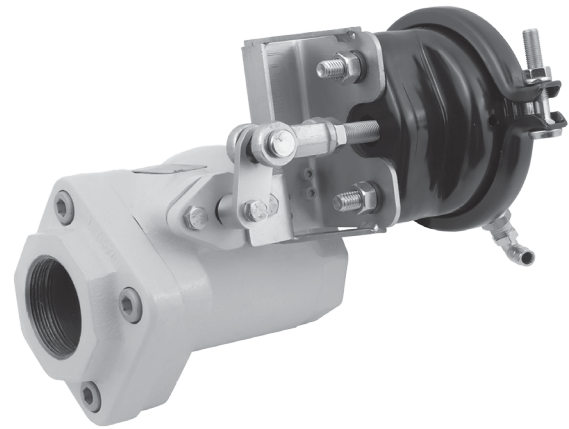

P1187

Figure 1. Type P539A Installed on N550/N551 Series (ESV)

WARNING

To prevent personnel injury and or property, before starting any type of repair, close off the upstream valves and remove all gas pressure from both the outlet and inlet sides of the N550/N551 Series Emergency Shut-off Valve (ESV).

Type P539 Removal

Refer to Figure 4. The following repair steps can be completed with the N550/N551 Series (ESV) installed in the line:

1. Follow Warning above and depressurize the inlet and outlet side of the Emergency Shut-off Valve (ESV).
2. Ensure there is no pressure on the pressure supply line to the actuator.

Type P539A

Specifications

The Specification section below shows specifications for the Type P539A Pneumatic Actuator.

Pressure Source Air or Nitrogen	Temperature Capabilities⁽²⁾ -40 to 150°F / -40 to 66°C
System Pressure Limits⁽¹⁾ Minimum: 20 psig / 1.4 bar Maximum: 30 psig / 2.1 bar ⁽²⁾ Recommended: 20 to 25 psig / 1.4 to 1.7 bar	Return Mechanism Internal spring, no air
	Melt Point, Fuse Link 212°F / 100°C

1. The pressure/temperature limits in this Instruction Manual and any applicable standard or code limitation should not be exceeded.
2. Pressures in excess of 30 psig / 2.1 bar shorten the service life of the N550/N551 Series valve.
Note: Maximum pressure rating for the brake chamber is 125 psig / 8.6 bar.

3. Remove cotter pin (key 8D) and clevis pin (key 8C) from the clevis (key 8B) eye.
4. Remove the bolt (key 7) from the ESV input shaft.
5. Remove the lever (key 5) and the spacer (not shown).
6. Remove the mounting cap screws (key 15) and the spacer (not shown) which attach the Type P539 mounting bracket to the N550/N551 Series.
7. Remove both gland bolts of N550/N551 Series ESV (Figure 2) in order to remove the Type P539 assembly from the valve.

Once the gland bolts are removed, the retainer plate, see Figure 2, of N550/N551 Series ESV will rotate 1/2 turn counter clockwise. It is VERY IMPORTANT that the retainer plate be turned 1/2 turn clockwise prior to re-installing the gland bolts and installing the new Type P539A hardware kit.

Installing Type P539A Replacement Hardware Kit

Refer to Figure 4.

1. Remove the Brake Chamber Assembly (key 8) from the Mounting Bracket (key 1) by removing the two nuts/lockwashers (key 7). Keep the nuts and lockwashers.
2. Using the nuts and lockwashers, assemble the Brake Chamber assembly to the new bracket (key 1).
3. Mount the actuator bracket onto the ESV's rear gland bolt (Figure 2) and in the same direction as shown in Figure 4. Rotate the retainer plate 1/2 turn clockwise before reinstalling the rear gland bolt. Refer to Figure 2. Tighten the gland bolts (Figure 2) evenly with a minimum torque of 8 ft-pounds / 11 N•m.

DO NOT OVER TIGHEN THE GLAND BOLT as overtightening the gland can cause the ESV shaft to bind.

4. Install the cap screws (key 15) through hole in the bracket and attach to the N550/N551 Series body.

Assembly to Type N550-10/N551-10

To install the Type P539A to the Type N550-10/N551-10, NPS 1-1/4 / DN 32 size, you must utilize the adaptor plate which was used to attach the latch block. Remove the adaptor plate and attach to the actuator mounting bracket as shown in Figure 3. Then mount the assembly to the N550/N551 Series body.

5. Put the lever on the ESV shaft and then reinstall the bolt (key 7) and the lockwasher (key 7).
6. Connect the actuating pressure line tubing to the air port (key 10), quick connect fitting.

Note

The clevis (key 8B) is factory installed such that the clevis eye is at 3 in. / 76 mm from the face of the brake chamber for optimal installation on N550/N551 Series. Some additional adjustments may need to be made to get complete valve closure.

After installing the Type P539A Retrofit Kit, operate the actuator with pressure to see that it smoothly opens and closes the N550/N551 Series without sticking or jamming. Check to make sure the N550/N551 Series shuts tightly.

If the actuator does not close the ESV pressure tight after assembling the Type P539A Actuator then, adjust the clevis' position by loosening the clevis nut (key 8E) and adjust the clevis' (key 8B) position to fit the lever (key 5) on the ESV shaft, then tighten the clevis nut to hold the clevis at this position.

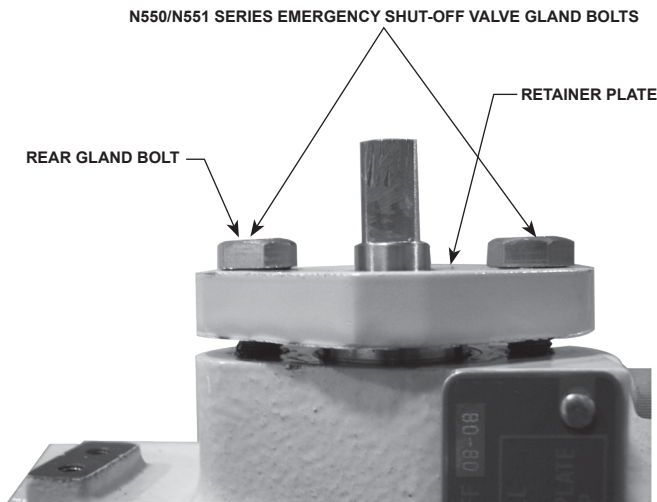

Figure 2. Tighten Gland Bolts Evenly to Keep Retainer Plate Parallel to the Valve Body

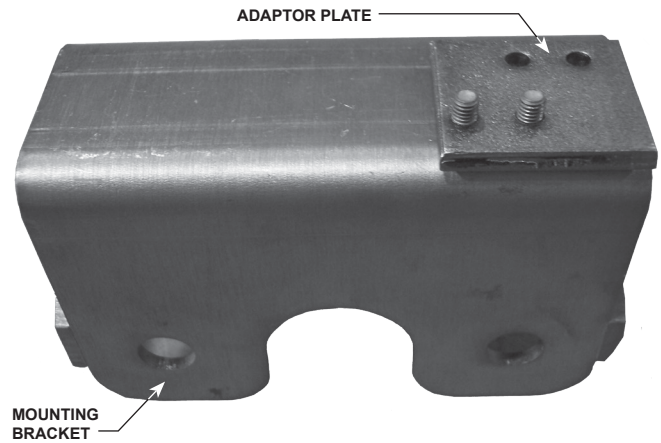

Figure 3. NPS 1-1/4 Bracket Adaptor

Three-Way Valve Operation for Type P5394A Actuator

If not already installed, a small three-way control valve (sold separately, part number T1139599012) for pneumatic ESV installations can be used as primary control (used to open or close the ESV) or an auxiliary remote release (close only).

Placing the valve's button in the upward position permits pressure to the actuator; pushing the button down exhausts pressure to close all valves connected to the system.

Maintenance

WARNING

Only qualified service person should attempt to repair these valves. Before starting any type of repair, close off the upstream valve and remove all pressure from both the inlet and outlet of the N550/N551 Series Emergency Shut-off Valve (ESV).

Because the actuator has a diaphragm seal and no rod bearing, internal lubrication is not required. Periodic lubrication of the operating lever/clevis pivot is recommended.

At least once a month inspect and check the following things:

1. Make that the actuator fully opens and closes the ESV without sticking. Keep actuator's rod free of any build-up of mud and corrosive or other foreign materials. Such build-up could prevent the actuator from closing which could jam the internal valve in the open position. Do not permit this condition to occur.
2. Make sure that the lever and clevis are working smoothly. The latch parts and lever are easily accessible for replacement or repair by removing the securing bolts (key 7).
3. Check for packing and joint leakage on the N550/N551 Series valve.

Type P539A

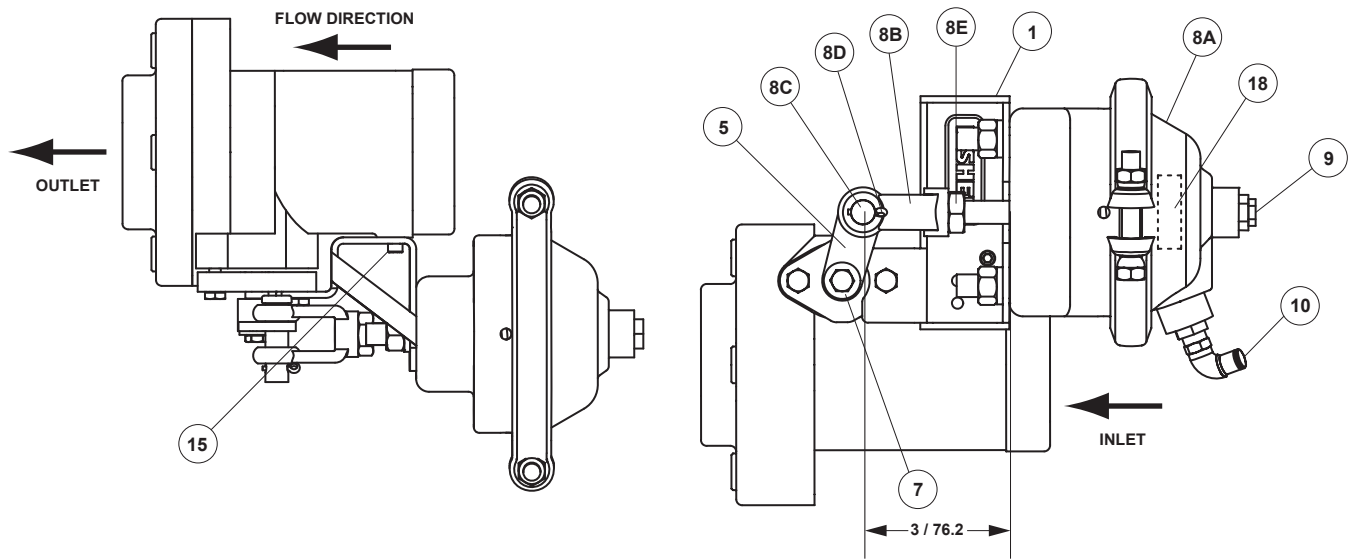

In. / mm

Figure 4. Type P539A Pneumatic Actuator Assembly

Parts List

Type P539A

Key	Description	Part Number	Key	Description	Part Number
1	Mounting Bracket	GE40106T012	8C	Clevis Pin	GE33511X012
5	Lever	GE38552T012	8D	Cotter Pin	GE33526X012
7	Lockwasher	V120006X012	8E	Hex Nut	T12086X0022
8	Brake Chamber Assembly	GE40920X012	9	Fuse Plug	T1033699982
8A	Brake Chamber	GE40919X012	10	Push-in Fitting	GE33586X012
8B	Clevis	GE33509X012	15	Hex Head Cap Screw (4 required)	1D617032992

LP-Gas Equipment

Emerson Process Management Regulator Technologies, Inc.

USA - Headquarters
McKinney, Texas 75070 USA
Tel: +1 800 558 5853
Outside U.S. +1 972 548 3574

For further information visit www.fisherregulators.com

The Emerson logo is a trademark and service mark of Emerson Electric Co. All other marks are the property of their prospective owners. Fisher is a mark owned by Fisher Controls International LLC, a business of Emerson Process Management.

The contents of this publication are presented for informational purposes only, and while every effort has been made to ensure their accuracy, they are not to be construed as warranties or guarantees, express or implied, regarding the products or services described herein or their use or applicability. We reserve the right to modify or improve the designs or specifications of such products at any time without notice.

Emerson Process Management Regulator Technologies, Inc. does not assume responsibility for the selection, use or maintenance of any product. Responsibility for proper selection, use and maintenance of any Emerson Process Management Regulator Technologies, Inc. product remains solely with the purchaser.