

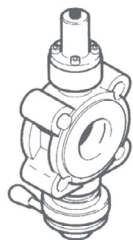

## NEOTECHA SAPRO SAMPLING DEVICES

### MAINTENANCE AND REPAIR INSTRUCTIONS

Before installation these instructions must be fully read and understood



Wafer body bayonet adaptor



Wafer body bottle adaptor

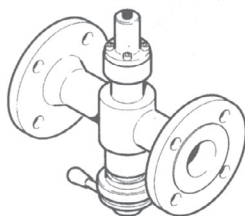

Flanged body bayonet adaptor

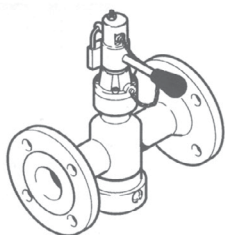

Flanged body bottle adaptor



Sapro piston syringe

### 1 SAPRO SAMPLING DEVICES

Thank you for purchasing Neotecha sampling equipment. These products incorporate the latest in design and mated technology and require little maintenance when applied and cared for correctly.

Before undertaking any maintenance work on Neotecha Sapro sampling devices the following instructions should be read and understood thoroughly. Any questions about these instructions should be directed to Neotecha or any authorized distributor.

### 2 OPERATION

Details of the installation and operating procedures will be found in a separate publication: Maintenance and Installation Instructions VCIOM-01977 and VCIOM-01978.

### 3 SAFETY

Prior to any disassembly, ensure that the unit has been thoroughly cleaned. In every case, protective equipment such as gloves, eye protection etc., should be used when operating, cleaning or maintaining the system. Attention must be given to any national or company regulations regarding dangerous media. Environmental protection regulations may vary according to the country or industry involved and must be strictly observed.

# NEOTECHA SAPRO SAMPLING DEVICES

## MAINTENANCE AND REPAIR INSTRUCTIONS

### 4 ROUTINE INSPECTION

Sapro sampling valves and syringes are precision engineered devices and need to be kept clean and well maintained to ensure perfect operation. The Sapro units should be inspected periodically to ensure that seals are not leaking, as follows:

#### a. Valve seat

Excessive moisture on the head of the safety plug may indicate a leaking valve seat. (Refer to replacement instruction further on).

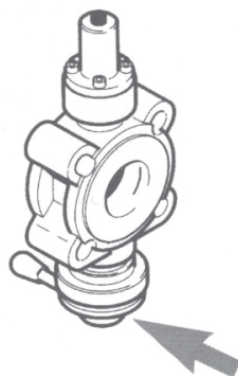

#### b. Spindle seal

Remove the yellow screwed plastic plug at the leak detection port on the Sapro valve body. Excessive moisture at this point may indicate a leaking spindle seal. (Refer to replacement instructions further on).

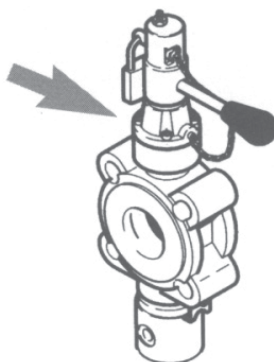

#### c. Syringe nozzle seal

When a sample has been drawn into the syringe, examine the nozzle seal area and the O-ring and piston seals on the cylinder. Any leakage indicates the need to replace the relevant seals. (Refer to replacement instruction further on).

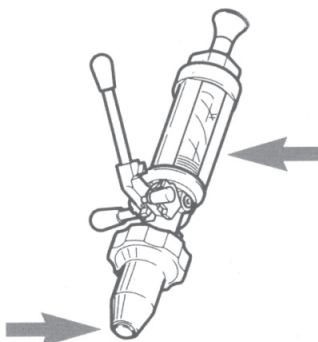

### 5 CLEANING THE SYRINGE

After each use of the Sapro syringe, the unit should be cleaned by thoroughly rinsing with an appropriate cleaning fluid as follows:

1. Press the operating lever (8) against the cylinder cage (9) and lock into position by moving with the locking lever (6) from position B and to position C.
2. Immerse the tip of the nozzle into a jar containing the cleaning fluid.
3. Pull and push the piston rod repeatedly until the syringe cylinder is clean.

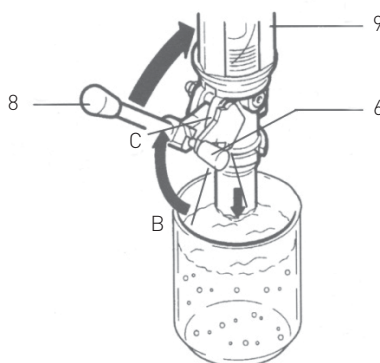

Cleaning the syringe

Figure 1

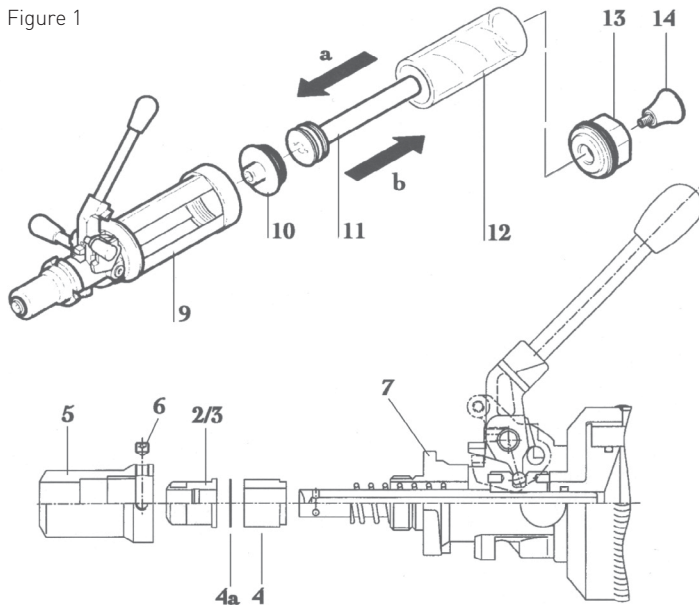

Figure 2

**6 SAPRO SYRINGE: MAINTENANCE**

**6.1 Syringe disassembly**

Disassembly of the syringe unit for cleaning, sterilization or replacement of components, is undertaken as follows (see Fig. 1).

1. Unscrew the cage end cap (13) and remove the cylinder assembly (10, 11, 12, 13 and 14) from the syringe cage (9).
2. Unscrew the grip (14) and remove the cage end cap (13).
3. Push the piston assembly (11) out of the cylinder (12) in the direction of arrow (a), thus pushing off the cylinder base (10) from the cylinder. The direction of removal is important to prevent damage to the piston seals.
4. Clean all disassembled parts and replace as necessary.

**CAUTION**

*Reassemble the syringe by reversing the above procedure, ensuring that the piston is inserted into the cylinder in the direction of arrow (b).*

**6.2 Replacement of syringe nozzle seal**

If the nozzle seal is leaking, it should be replaced by implementing the following procedure.

**6.3 Seal removal (see Fig. 2)**

1. With the syringe cap removed, loosen the two set screws (6).
2. Unscrew the nozzle (5) from the syringe head (7).
3. Ensure that the spacer (4) and washer (4a) are removed from the nozzle.
4. Place the nozzle on a firm surface. Place tool No. 1 on top of the nozzle and tap with a mallet until the nozzle seal assembly (2 and 3) falls out of the nozzle (see Fig. 3).

**6.4 Seal replacement**

1. Place the nozzle (5) in tool No. 4, as shown (see Fig. 4).
2. Apply a little silicone oil to the replacement nozzle seal assembly (2 and 3) and insert it into the nozzle cavity.
3. Insert tool No. 3 into the nozzle and place tool No. 2 over tool No. 3, as shown.
4. Tap tool No. 2 with a mallet until the nozzle seal assembly is correctly located within the nozzle.
5. Replace the spacer (4) and washer (4a) over the syringe spindle as shown in Fig. 2.
6. Replace the nozzle assembly over the syringe spindle and screw into position.
7. Secure the nozzle by tightening set screws (6).

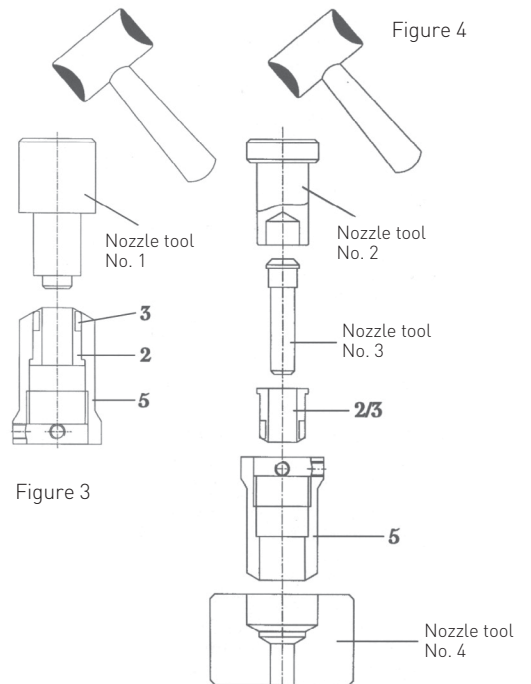

**7 VALVE SEAT REPLACEMENT**

**A. Bottle adaptor models**

- 1 *Wafer body design (see Fig. 5 and Fig. 6)*  
 You will need: repair kit - SV-Set 1 and tool kit - SV-W2.
  - 1.1 Take the Sapro valve from the pipe line.
  - 1.2 Loosen the socket head screw (1d) and remove the safety claw (1c).
  - 1.3 Unscrew and remove bottle adaptor (5a).
  - 1.4 Loosen the set screw (1a).
  - 1.5 Using the 2-pin wrench (provided in tool kit SV-W2), unscrew the retaining ring (5), to reveal the valve seat assembly O-ring (3a), soft seal (3) and valve seat (4).
  - 1.6 Clean the bottle adaptor, valve seat and retaining ring.
  - 1.7 Replace the O-ring (3a) and seat seal (3) with new parts from the repair kit SV-Set 1.

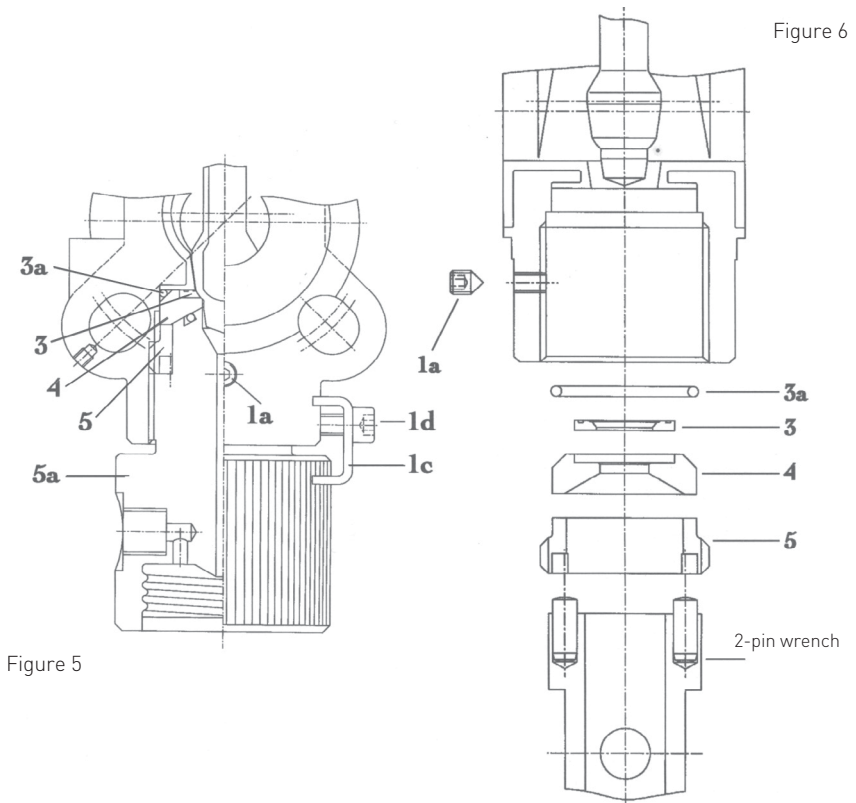

Figure 5

Figure 6

- 2 *Flanged body design (see Fig. 7 and Fig. 8)*  
 You will need: repair kit - SV-Set 1 and tool kit - SV-W2.
  - 2.1 Take the Sapro valve from the pipeline.
  - 2.2 Loosen the three set screws (5a) and withdraw the bottle adaptor assembly.
  - 2.3 Remove the four socket head screws (1a) and withdraw the retaining flange (5) to reveal the valve seat assembly O-ring (3a), soft seal (3) and valve seat holder (4).
  - 2.4 Clean the bottle adaptor, retaining flange and valve seat.
  - 2.5 Replace the O-rings (3a, 5d) and seat seal (3) with new parts from the seal kit SV-Set 1.
  - 2.6 Reassemble by reversing the above procedure.

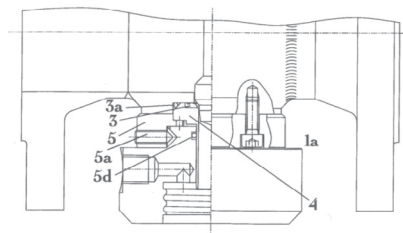

Figure 7

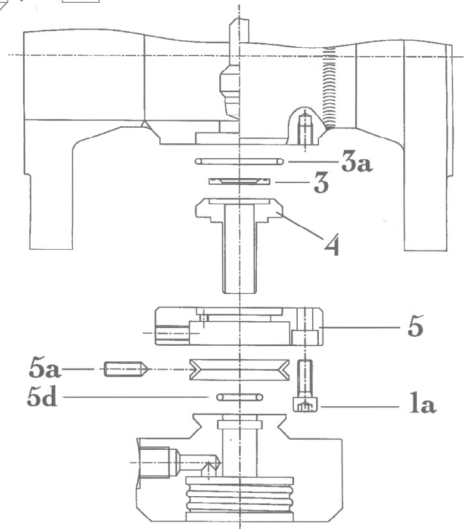

Figure 8

# NEOTECHA SAPRO SAMPLING DEVICES

## MAINTENANCE AND REPAIR INSTRUCTIONS

### B. Bayonet adaptor models

- 3 *Wafer body design (See Fig. 9 and Fig. 10)*  
 You will need: repair kit - SV-Set 1 and tool kit - SV-W1.
- 3.1 Take the Sapro from the pipeline.
  - 3.2 Loosen the set screws (1a) and unscrew the bayonet adaptor assembly (5) to reveal the valve seat assembly O-ring (3a), seat seal (3) and valve seat (4).
  - 3.3 Clean the bayonet adaptor assembly, valve body recess and valve seat.
  - 3.4 Replace the O-ring (3a) and seat seal (3) with new parts from the seal kit SV-Set 1.
  - 3.5 Reassemble by reversing the above procedure.

- 4 *Flanged body design (see Fig. 11 and Fig. 12)*  
 You will need: repair kit - SV-Set 1 and tool kit - SV-W1.
- 4.1 Take the Sapro from the pipeline.
  - 4.2 Remove the four socket head screws (1a) and withdraw the bayonet adaptor assembly (5) to reveal the valve seat assembly O-ring (3a), seat seal (3) and valve seat (4).
  - 4.3 Clean the bayonet adaptor assembly, valve body recess and valve seat.
  - 4.4 Replace the O-ring (3a) and seat seal (3) with new parts from the seal kit SV-Set 1.
  - 4.5 Reassemble by reversing the above procedure.

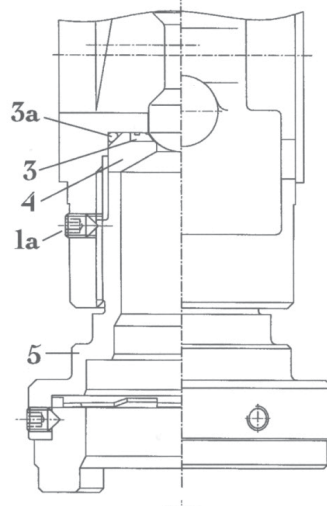

Figure 9

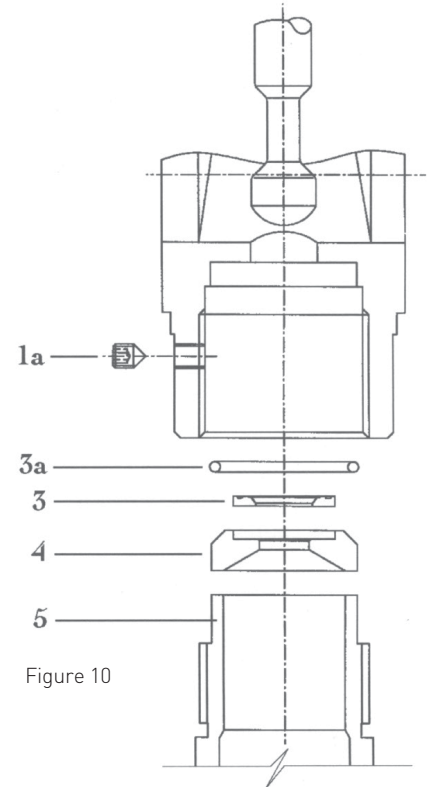

Figure 10

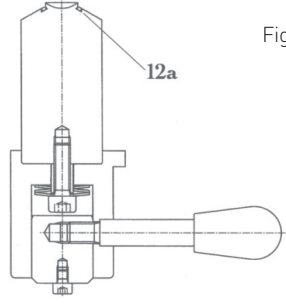

Figure 11

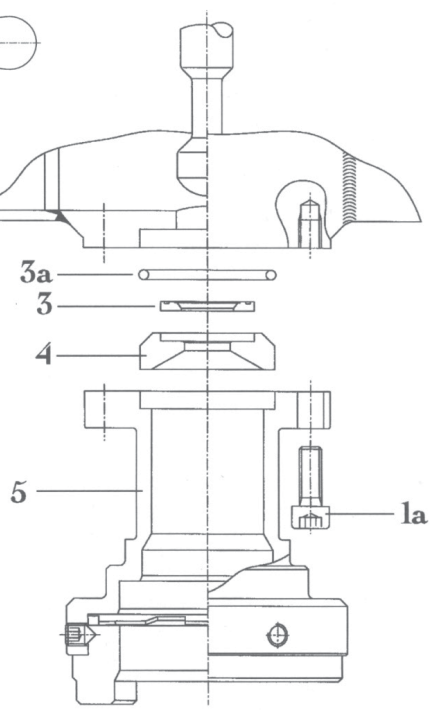
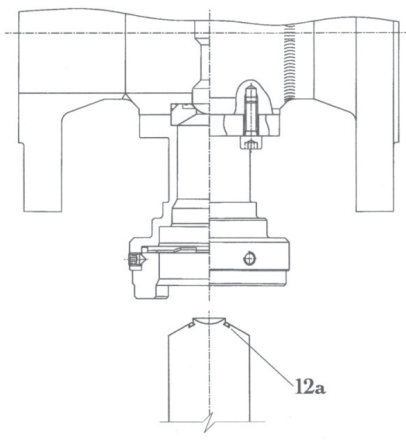

Figure 12

# NEOTECHA SAPRO SAMPLING DEVICES

## MAINTENANCE AND REPAIR INSTRUCTIONS

### 8 SPINDLE SEAL REPLACEMENT

#### A. Bonnet disassembly

If excessive moisture is found on examination of the leak detection port (see earlier) this may be due to wear of the spindle seal. Replacement of spindle seals should be undertaken by implementing the following procedure.

1. Identify the model number of the Sapro valve under consideration. The model number of a Sapro valve is given on a metal tag attached to the exterior of the valve bonnet.
2. Referring to Tables 1 and 3, identify the appropriate repair kit and tool kit required for the subject Sapro valve.
3. Remove the Sapro valve from the pipeline.

#### NOTES

For bottle adaptor units with handlever only (see Fig. 13)

- a. Unscrew the handlever (10a).
- b. Slide off the protective (10b).
- c. Remove adjustment screw (9a) and lock nut (9b).

#### CAUTION

The bonnet (9) is under spring tension. Follow these instructions carefully.

4. Remove two opposing socket head screws (8) replacing them with the two threaded rods from the spring tension device from tool kit SV-W3.
5. Place the two-hole plates over the threaded rods followed by the washers and secure with wing nuts as shown in Fig. 13.1/14.1.
6. Remove the remaining two socket head screws.
7. Gradually loosen the wing nuts until the spring tension in the bonnet is completely relieved and then remove the threaded rods.
8. Remove bonnet (9) and gasket (8a) from the valve body.
9. On bayonet adaptor models only: remove and replace the X-ring seal (9a) (see Fig. 14).
10. Remove the spring (11c) from the spindle.
11. Clamp the end of the spindle assembly in a soft jawed vice and pull the body away from the spindle assembly.
12. Separate all parts of the spindle assembly as shown in Fig. 15 and identify replacement components from the appropriate repair kit.

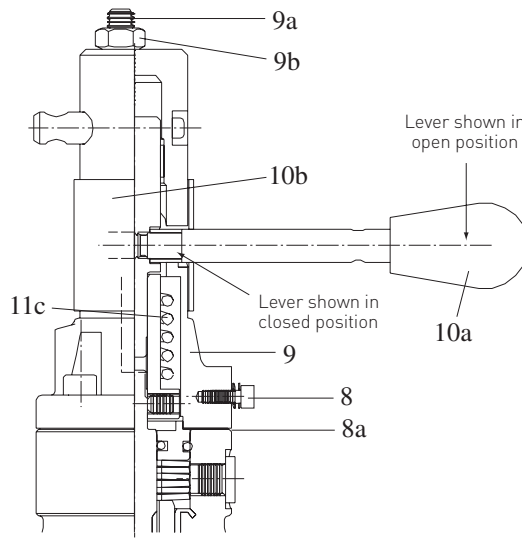

Figure 13

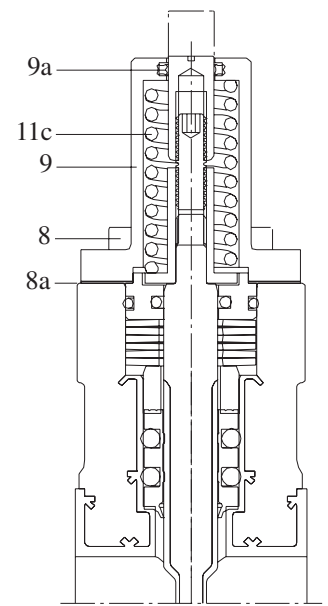

Figure 14

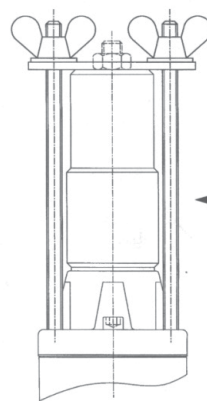

Figure 13.1

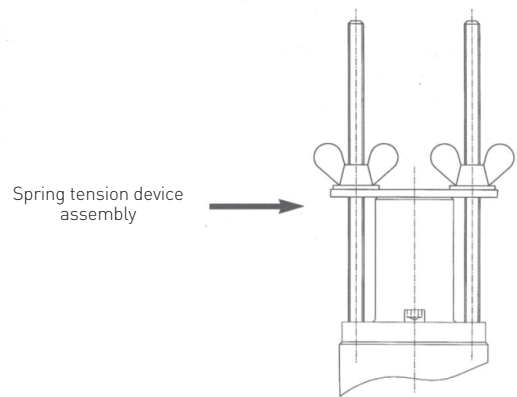

Figure 14.1

# NEOTECHA SAPRO SAMPLING DEVICES

## MAINTENANCE AND REPAIR INSTRUCTIONS

### B. Seal assembly

**NOTE**

It is recommended that all soft seal components be replaced at the same time.

- Referring to Tables 1 and 3, identify the repair kit, spindle seal type and tool kit required for the subject Sapro valve.
- Secure Sapro valve body upright in a vice. Take care not to damage PFA sealing faces.
- Apply a little silicone oil to all the commencing assembly.
- Refer to the assembly instructions below for the relevant spindle seal type A or B (see Table 1).

#### 1 Spindle seal assembly types A and B

- 1.1 Introduce valve spindle (2) into the Sapro body until it rests on the valve seat.
- 1.2 Position the spindle seal (6) over the spindle and push down using the spindle seal drive tool included in tool kit SV-W3. Gently tap the drive tool with a mallet until the spindle seal locates at the bottom of the cavity.
- 1.3 Position the other spindle assembly components, in order, on the spindle, as indicated in Fig. 15 A and B, replacing the parts contained in the appropriate repair kit.
- 1.4 Proceed with bonnet assembly as described in the next section.

Figure 15  
Sapro valve spindle seal types

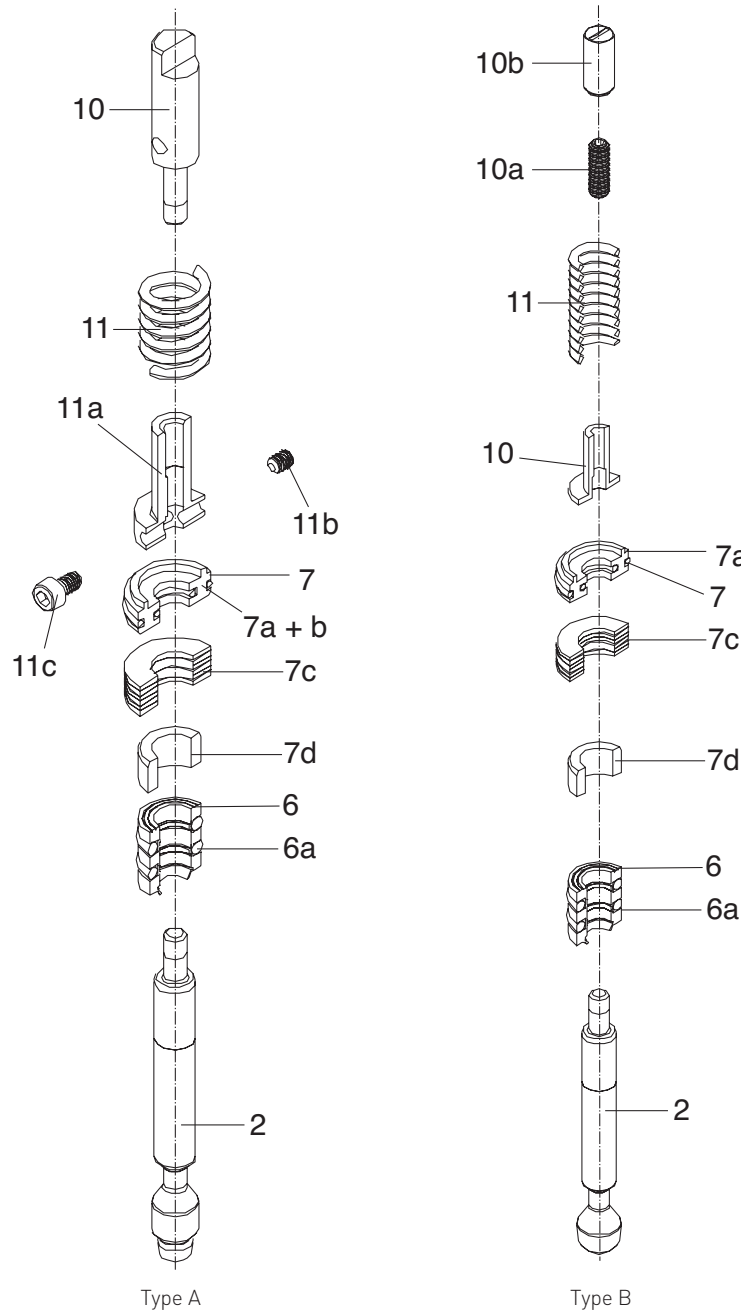



# NEOTECHA SAPRO SAMPLING DEVICES

## MAINTENANCE AND REPAIR INSTRUCTIONS

### C. Bonnet re-assembly

1 *Bayonet adaptor units only (spindle seal type B) [see Fig. 16]*

- 1.1 Position gasket (8a) on valve body.
- 1.2 Screw spring support (10) onto the spindle until finger tight, then back off by a quarter turn.
- 1.3 Position the coil spring (11) over the spring support.
- 1.4 Position the bonnet onto the valve body over the coil spring and screw the two threaded rods, from the spring tension device in tool kit SV-W3, into opposing holes in the valve body.
- 1.5 Place the two-hole plate over the threaded rods, followed by the washers and tighten the bonnet onto the valve by means of the wing nuts.
- 1.6 Screw two socket head screws (8) into the two remaining bonnet/body holes and tighten.
- 1.7 Remove the spring tension device and replace with two socket head screws (8). Tighten all four screws to ensure full compression of the coil spring.
- 1.8 Screw the position indicator (10b) lightly onto the cap head screw (10a) through the top of the bonnet, ensuring that it is finally flush with the bonnet.

2 *Bottle adaptor units only (spindle seal type A) [see Fig. 17 and Fig. 18]*

- 2.1 Position the gasket (8a) on the valve body.
- 2.2 Screw the spring support (11a) onto the spindle until contact is made with the lantern ring (7a).

- 2.3 Screw the tie rod (10) into the spring support until hand tight; then turn the tie rod counter clockwise until the hole in the tie rod is aligned with the next hole in the spring support.
- 2.4 Position the locating screw (11c) in the spring support hole which is aligned with the non-countersunk side of the tie rod hole [see Fig. 19].
- 2.5 Fix the spring support to the spindle by means of the securing screw (11b) in the hole opposite the locating screw.
- 2.6 Rotate the spindle assembly until the securing screw is aligned with the leak detection port in the valve body. (This port has a yellow plastic blanking plug).
- 2.7 Place the coil spring (11) over the spring support (11a).
- 2.8 Position the bonnet over the coil spring ensuring that the locating screw (11c) aligns with the key way in the bonnet.
- 2.9 Applying hand pressure on the bonnet to compress the coil spring, secure the bonnet to the valve body using the cap head screws (8).
- 2.10 Slide protective sleeve (10b) over bonnet.
- 2.11 Locate the roller sleeve (10c) onto the handle lever and screw the handle lever (10a/b) into the tie rod (through the bonnet).

- 2.12 When lateral play is satisfactory, remove the handle lever and roller sleeve (10a/b/c).
- 2.13 Slide the protective sleeve (10b) into position over the bonnet.
- 2.14 Re-fit the roller sleeve to the handle lever and the handle lever to the tie rod (through the bonnet).
- 2.15 Position the locking pin (9e) through the bonnet. Try to operate the handle lever counter clockwise and check that the spindle does not move off the valve seat.
- 2.16 Screw the set screw (9a) with hexagon nut (9b) into the bonnet.

#### NOTE

Ensure that the handle lever has a lateral play of minimum 7 mm and maximum 20 mm (refer to Fig. 17). If lateral play requires adjustment:

- a. Remove handle lever and bonnet, as previously described.
- b. Loosen the securing screw (11b) to free the spring support from the spindle.
- c. Rotate the spring support a quarter turn counter clockwise and re-tighten securing screw.
- d. Rotate spindle assembly until the securing screw is again aligned with the leak detection port.
- e. Repeat assembly from instruction [2.7].

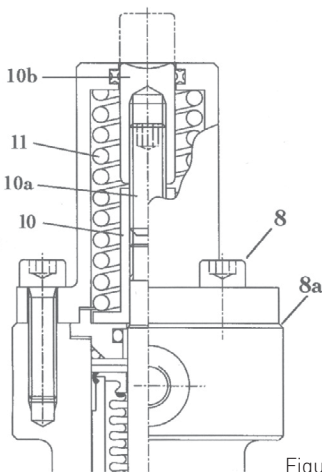

Figure 16

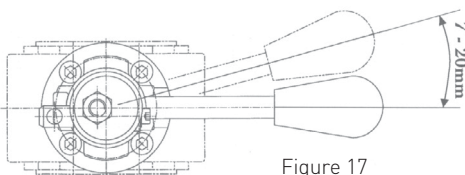

Figure 17

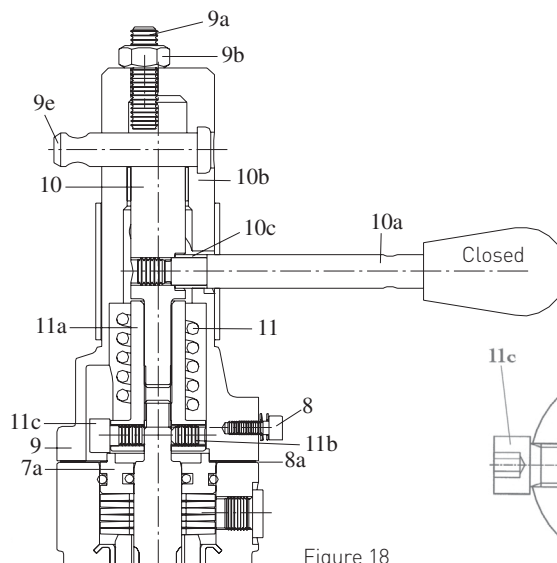

Figure 18

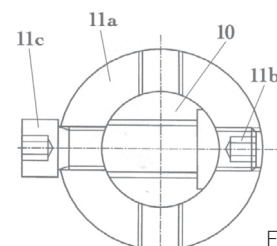

Figure 19



# NEOTECHA SAPRO SAMPLING DEVICES

## MAINTENANCE AND REPAIR INSTRUCTIONS

### Stroke adjustment

The degree of opening of the sampling valve can be adjusted to the users requirements.

1. Loosen the lock nut (9b) and back off the set screw (9a).
2. Remove the locking pin.
3. Operate the handlever to open the valve to the required extent.
4. With the handlever held in this position, screw down the set screw (9a) as far as possible and release the handlever.
5. Tighten the hexagon nut (9b) to lock the position of the set screw.
6. Replace the locking pin (9e).

**TABLE 1 - REPAIR KITS FOR SAPRO VALVE SEATS AND SPINDLE SEALS**

Ref. nr.	Description	Sapro model nr.	Spindle seal type	Kit contents	
				Part	Nr.
SV-SET1	Repair kit seat seal on all Sapro sampling valves	All	N/A	Soft seal	3
				O-ring	3a
				Set screw	1a
SV-SET9	Repair kit bottle adaptor seal	All valves with bottle adaptor		O-ring	5b
SV-SET10	Repair kit soft parts TFM stem lip seal Size range DN 25 (NPS 1) to DN 100 (NPS 4)	SV.....S..	TFM stem seal	Sealing sleeve	6
				O-ring set	6a
				PTFE/FKM seal ring	7a
				Gasket	8a
				O-ring	7b
SV-SET11	Repair kit soft parts TFM stem lip seal and Belleville set Size range DN 25 (NPS 1) to DN 100 (NPS 4)	SV.....S..	TFM stem seal	Sealing sleeve	6
				O-ring set	6a
				PTFE/FKM seal ring	7a
				Gasket	8a
				O-ring	7b
				Belleville set	7c
				Spacer	7d
				Compression sleeve	7
SV-SET12	Repair kit spindle seal Size range DN 25 (NPS 1) to DN 100 (NPS 4)	SV.....A..	Welded bellow seal	Guide ring	7a
				O-ring	7b
				O-ring	7c
				Gasket	8a

**TABLE 2 - REPAIR KITS FOR SAPRO PISTON SYRINGES**

Ref. nr.	Description	Syringe size	Contents	
			Part	Nr.
SK-SET1	Maintenance of nozzle seal on Sapro piston syringe	All	Sealing sleeve	2
			Pressure ring	3
SK-SET2	Maintenance of soft seals on Sapro piston syringes	20 ml	X-ring	17
			O-ring	18
			O-ring	24a
SK-SET3	Maintenance of soft seals on Sapro piston syringes	50 ml and 100 ml	X-ring	17
			O-ring	18
			O-ring	24a
SK-SET4	Maintenance of soft seals on Sapro piston syringes	250 ml	X-ring	17
			O-ring	18
			O-ring	24a
SK-SET5	Replacement of piston head on Sapro piston syringes	20 ml	Piston head	21a
SK-SET6	Replacement of piston head on Sapro piston syringes	50 ml and 100 ml	Piston head	21a
SK-SET7	Replacement of piston head on Sapro piston syringes	250 ml	Piston head	21a

# NEOTECHA SAPRO SAMPLING DEVICES

## MAINTENANCE AND REPAIR INSTRUCTIONS

**TABLE 3 - TOOL KITS FOR SAPRO VALVES AND PISTON SYRINGES**

Ref. nr.	Description	Contents
SV-SETW1	Replacement of seat seal on all flanged Sapro valves and on wafer type Sapro's with bayonet adaptor	Metric hex key 3 mm Metric hex key 5 mm
SV-SETW2	Replacement of seat seal on wafer type Sapro valves with bottle adaptor	Metric hex key 3 mm 2-pin wrench
SV-SETW3	Replacement of spindle seals on all Sapro valves	Metric hex key 3 mm Metric hex key 4 mm Metric hex key 5 mm Spindle seal drive tool Spring tension device - 2 hole plate - 2x threaded rods - 2 wing nuts - 2 washers
SK-SETW1	Replacement of nozzle seal on all Sapro piston syringes	Metric hex key 3 mm Metric hex key 4 mm Nozzle tool nr. 1 Nozzle tool nr. 2 Nozzle tool nr. 3 Nozzle tool nr. 4

VCIOM-01984-EN © 2021 Emerson Electric Co. All rights reserved 04/21. Neotecha is a mark owned by one of the companies in the Emerson Automation Solutions business unit of Emerson Electric Co. The Emerson logo is a trademark and service mark of Emerson Electric Co. All other marks are the property of their prospective owners.

The contents of this publication are presented for informational purposes only, and while every effort has been made to ensure their accuracy, they are not to be construed as warranties or guarantees, express or implied, regarding the products or services described herein or their use or applicability. All sales are governed by our terms and conditions, which are available upon request. We reserve the right to modify or improve the designs or specifications of such products at any time without notice.

Emerson Electric Co. does not assume responsibility for the selection, use or maintenance of any product. Responsibility for proper selection, use and maintenance of any Emerson Electric Co. product remains solely with the purchaser.

[Emerson.com/FinalControl](http://Emerson.com/FinalControl)