

Protects loading and unloading systems for propane, butane and other pressurized fluids



FISHER™ Emergency Shutoff Valves for Railcars

Product advantages

- Flows greater than railcar excess flow valve capacity
- Available with and without excess flow
- Decades of safe and reliable service in the railcar industry
- NFPA 58 Compliant
- Fast Factory Certified Service

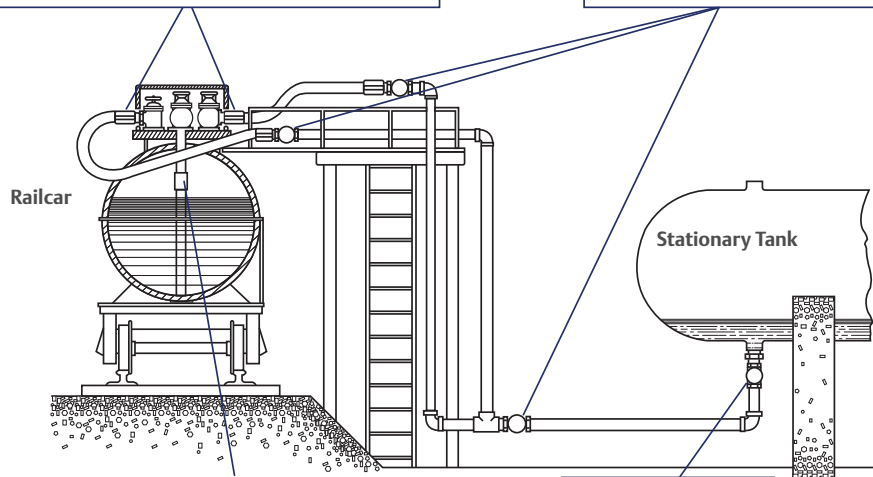
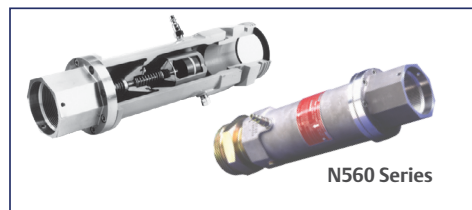

UL® is a mark owned by Underwriters Laboratories.

Emerson Automation Solutions

Americas
T +1 800 558 5853
T +1 972 548 3574

Europe
T +39 051 419 0611

Asia Pacific
T +65 6777 8211

Middle East / Africa
T +971 4811 8100

D450346T012 © 2014, 2020 Emerson Process Management Regulator Technologies, Inc. All rights reserved. 09/20.
The Emerson logo is a trademark and service mark of Emerson Electric Co. All other marks are the property of their prospective owners.
Fisher™ is a mark owned by Fisher Controls International LLC, a business of Emerson Automation Solutions.



EMERSON. CONSIDER IT SOLVED.™