

**Product Data Sheet**

SD 0300-2E05

September 2011

# Damcos® BRCF

Hydraulic single-acting balanced rotary actuator 90°  
(quarter-turn) fail-safe

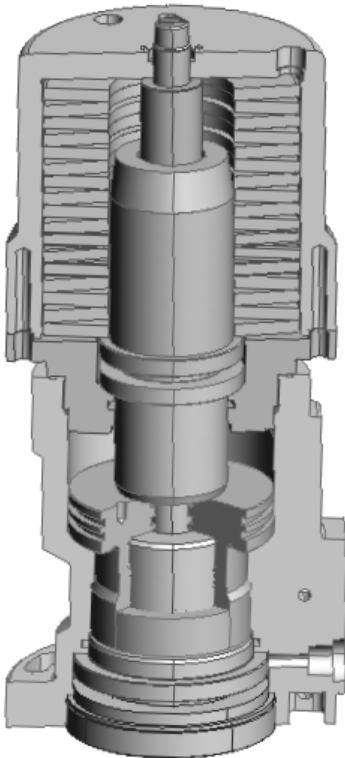

**Damcos®**



**EMERSON™**  
Process Management

# Damcos® BRCF

## The BRCF actuator for fail-safe operation of quarter-turn valves

- Unique and simple design with cross-over valve.
- Spring action by means of dished springs.
- Easy adaption to all well-known quarter-turn valves.
- Reliable and rugged, with more than 30 years service records on basic design.
- Compact with high-torque output.
- Also for operation in rough environment.
- Unlimited mounting positions and with built-in adjustments for end stops of rotary movement.
- Balanced rotary principle eliminates side forces and bending of valve shaft.

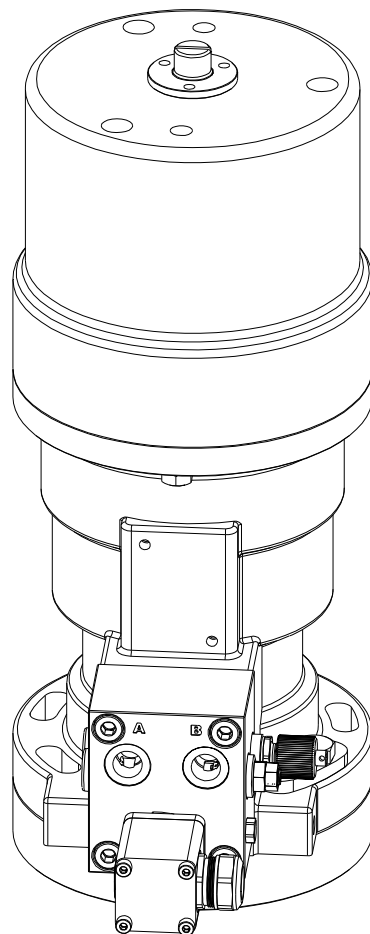

*Actuator mounted with control block and EI-indicator.*

## Product Data Sheet

SD 0300-2E05

September 2011

Damcos® BRCF

---

## Standard optionals

- EI on/off or continuous indication IP 68
- Connection block with f. ex. filter
- Single pilot operated non-return valve
- Release valve
- Throttle valve
- Quick connection for emergency operation with portable hand pump
- Built-on emergency operation hand pump
- Epoxy coating

### On request spec. features as:

- Flushing valve built into the connection block making it possible to flush the system without disconnection of pipes.
- Safety equipment as mechanical locking device of actuator in closed position.

## Control equipment

The BRCF actuators are designed for pipe connection to the G 1/4 actuator port.  
For further information please see separate data

sheets for the whole range of blocks and other actuator mounted control components. (Interface for Cetop 3 valves).

## Classification

Meets requirements from the major classification and approval authorities like:  
Det norske Veritas  
Lloyd's Register of Shipping  
American Bureau of Shipping

- RINA
- Russian Register of Shipping
- Bureau Veritas
- Germanischer Lloyd
- U.S. Coast Guard

## Manufacture

The BRCF actuators are manufactured in accordance with the guidelines for quality system stated in the ISO standard.  
After assembly each actuator is flushed

according to ISO 4406 21/19/16 standard and plugged.  
Flushing according to ISO 4406 18/16/13 standard can be performed on request.

## Damcos® BRCF

## Technical specification

Temperature range:	-20°C to +80°C, seals NBR (other temp. ranges on request)
Housing:	GGG 40
Piston:	GGG 40
Output shaft:	SS 2142
Dished springs:	50 CrV4
Indicator shaft:	AISI 316
Intermediate flange:	St 52-3
Adapter:	SS 2142
Coating:	Primer: Min. 40 micron, type Hempel EE 13140 Top coat: min. 25 micron alkyd, red no. 51320

## Operating restrictions

Please observe specific rules and demands from the classification societies and authorities concerning operating pressure and temperature range.

(Example - ABS: Max. operating pressure = 20% of burst pressure.)  
For extreme cycle speeds, loads and lifetime expectations please consult manufacturer.

The Emerson logo is a trademark and service mark of Emerson Electric Co. Damcos and the Damcos logotype are registered trademarks of Damcos A/S. All rights reserved. The contents of this publication are presented for information purposes only, and while effort has been made to ensure their accuracy, they are not to be construed as warranties or guarantees, expressed or implied, regarding the products or services described herein or their use or applicability. All sales are governed by our terms and conditions, which are available upon request. We reserve the right to modify or improve the designs and specifications of our products at any time without notice. Damcos A/S accepts no responsibility for any errors that may appear in this publication.

**This product is developed and managed by:**  
**Emerson Process Management**

Damcos A/S  
Aaderupvej 41  
DK-4700 Naestved  
T +45 5578 7200  
F +45 5578 7272

**For global contacts:**  
**[www.EmersonProcess.com/mtm](http://www.EmersonProcess.com/mtm)**