

# VPI

## Valve Position Indicator



## General Description

Basically the valve position indicator is a precision gear motor with a display indicating the flow of a certain oil volume through the unit. The gear wheels rotate according to flow and flow direction of the fluid. A built-in mini gear box with a gear ratio chosen to suit the actuator displacement in question transfers the gear motor movement to the indicator shaft. There is no mechanical connection between the gear motor and the indicator shaft.

The rotary movement of the hydraulic gear wheels is transferred to the indicator shaft by a magnetic clutch. This eliminates possible external leakages. An indicator arrow moves within a scale angle which is adjustable between 75° and 200°. A small indicator disc (flow indication) mounted firmly on the indicator shaft serves as leakage indicator.

## Versions

The VPI indicator is available in five versions:

- VPI-V: Visual indication
- VPI-E: Visual + electrical open/closed indication (switches)
- VPI-C: Visual + electrical analog (potentiometer) indication
- VPI-CE: Double electrical function C+E
- VPI-EE: Double electrical function E+E

Special versions may be mounted in Ex area and are equipped with cable.

Material	
Housing	ALMgSi 1.0 Anodized or Ms58, CuZn39Pb3
Screws	A4-70 and 12.9 or A4-80
Seals	NBR ~ Acrylonitrile Butadiene
Sight glass	PMMA
Weight	Approx. 1.2 kg ~ 2.7 lb
Top part/indicator	PPS, POM

Technical Specification	
Max. working pressure	135 bar ~ 1958 lbf/in <sup>2</sup>
Test pressure	225 bar ~ 2973 lbf/in <sup>2</sup>
Burst pressure	> 525 bar ~ 7615 lbf/in <sup>2</sup>
Temperature range	-20°C to 80°C ~ -4°F to 176°F
Viscosity range	15-200cSt
Filtration requirement	25 µm nominal
Hydraulic medium	Acid-free hydraulic oil
Max. flow	100 cm <sup>3</sup> /sec ~ 6 l/min
Min. flow	3 cm <sup>3</sup> /sec ~ 0.2 l/min
Connection face	DIN 24 340 Cetop-3 / VPI connection
IP class	Determined by connector (not included)

# Operating Restrictions

Flushing of control lines must never take place through the VPI.

## Main Dimensions

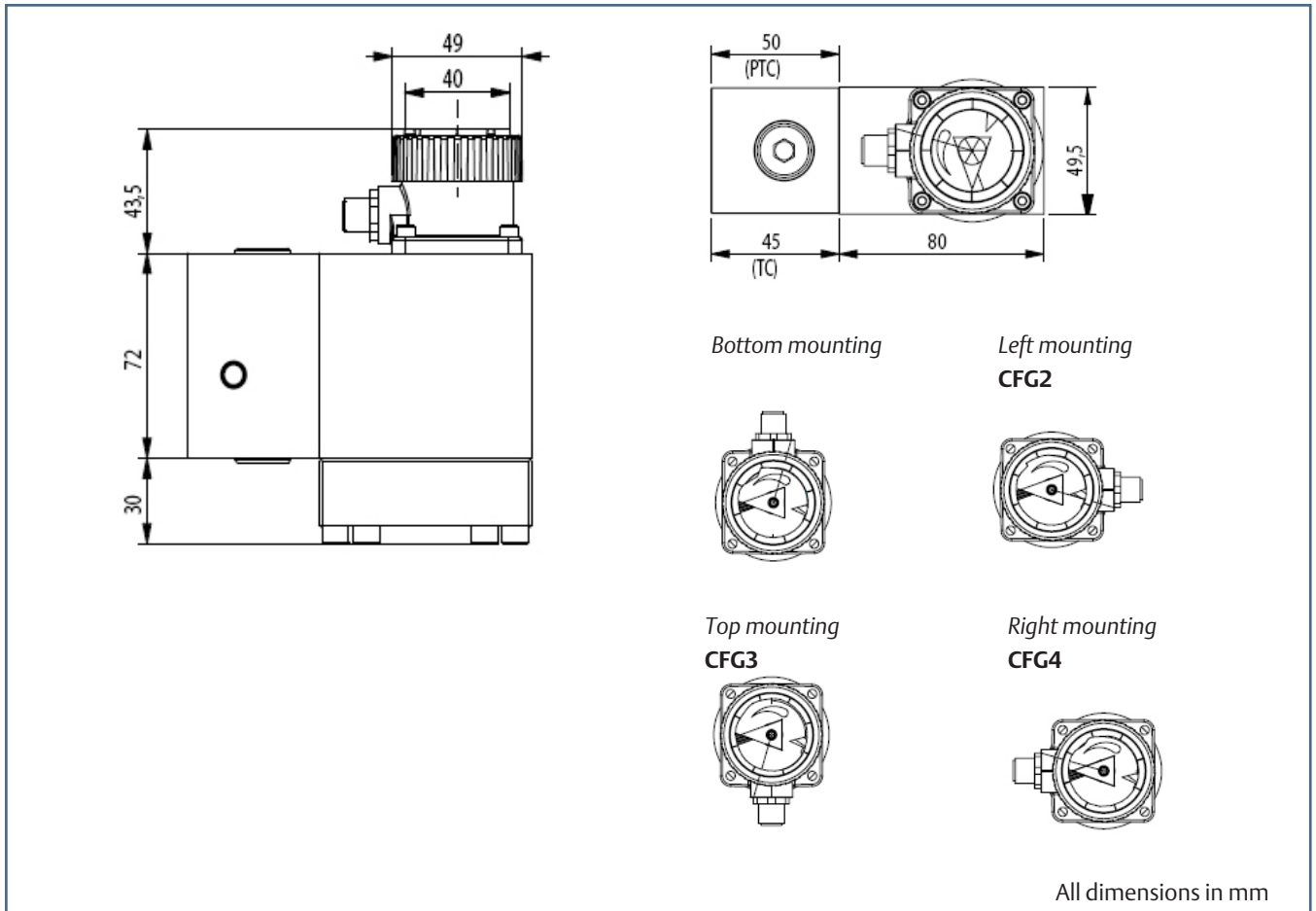

# Main Layout and Hydraulic Symbol

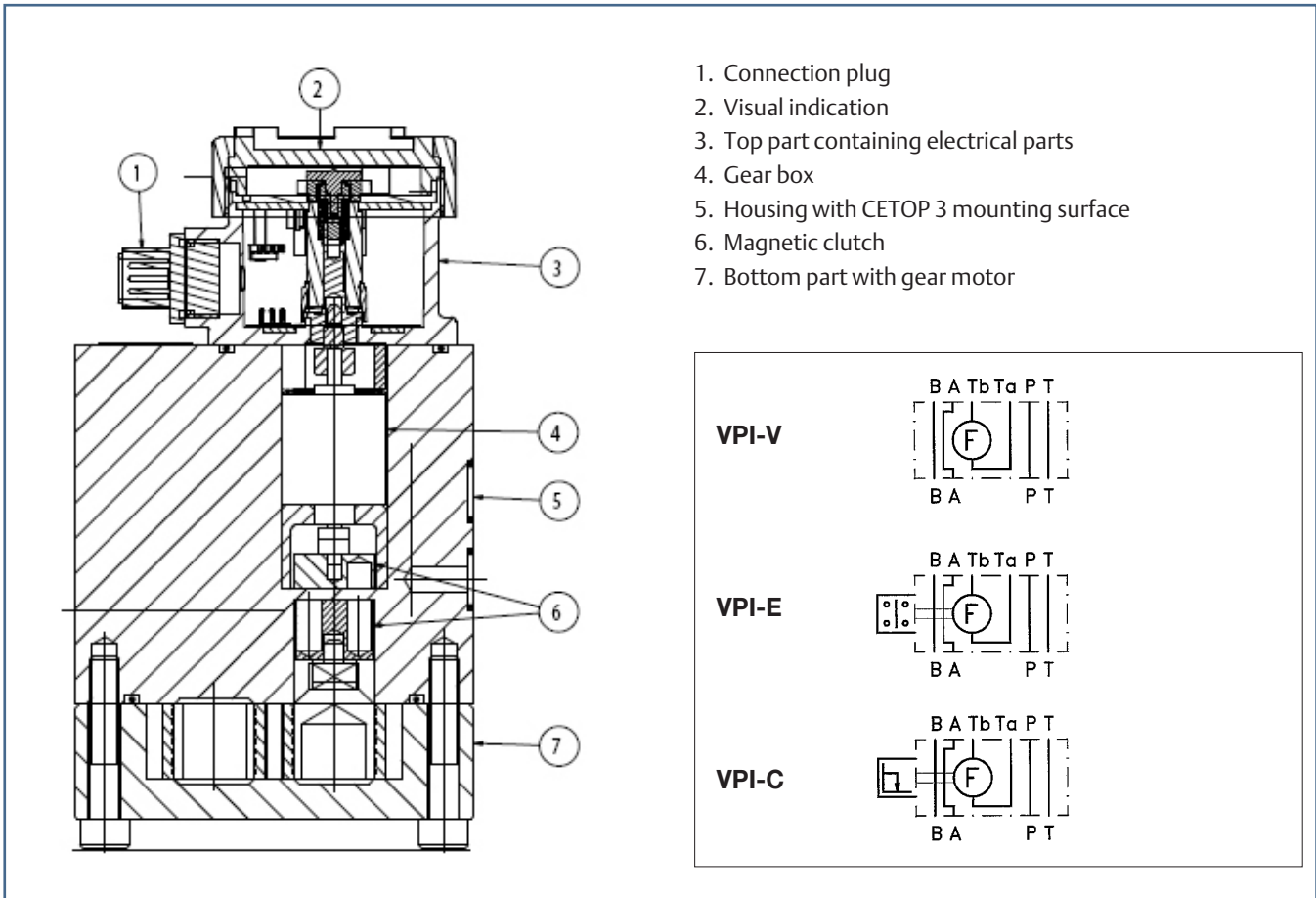

## Choice of Gear Box

Measuring range				Gear
cm <sup>3</sup>		in <sup>3</sup>		
From	Up to	From	Up to	Ratio 1
15	25	0.9	1.5	0015
25	40	1.5	2.4	0025
40	70	2.4	4.3	0040
70	100	4.3	6.1	0060
100	170	6.1	10.4	0100
170	260	10.4	15.9	0150
260	430	15.9	26.2	0250
430	700	26.2	42.7	0405
700	1250	42.7	76.3	0720
1250	2200	76.3	134.2	1280
2200	3500	134.2	213.2	2000
3500	5600	213.5	341.6	3125
5600	11000	341.6	671.0	6103

Measuring range for VPI-PTC:

- Actuator displacement

Measuring range for VPI-TC:

- Actuator displacement + compression of oil (1-1.5% of pipe volume)

Pipe size	Pipe volume each 10 metres		Compression volume each 10 metres		
	mm	cm <sup>3</sup>	in <sup>3</sup>	cm <sup>3</sup>	in <sup>3</sup>
Ø6		282.7	17.6	4.24	0.26
Ø7		384.8	23.5	5.77	0.35
Ø8		506.6	30.9	7.54	0.46
Ø9		636.0	38.8	9.54	0.58
Ø10		785.0	47.9	11.78	0.72

## Typical Application and VPI Combinations on Manifold

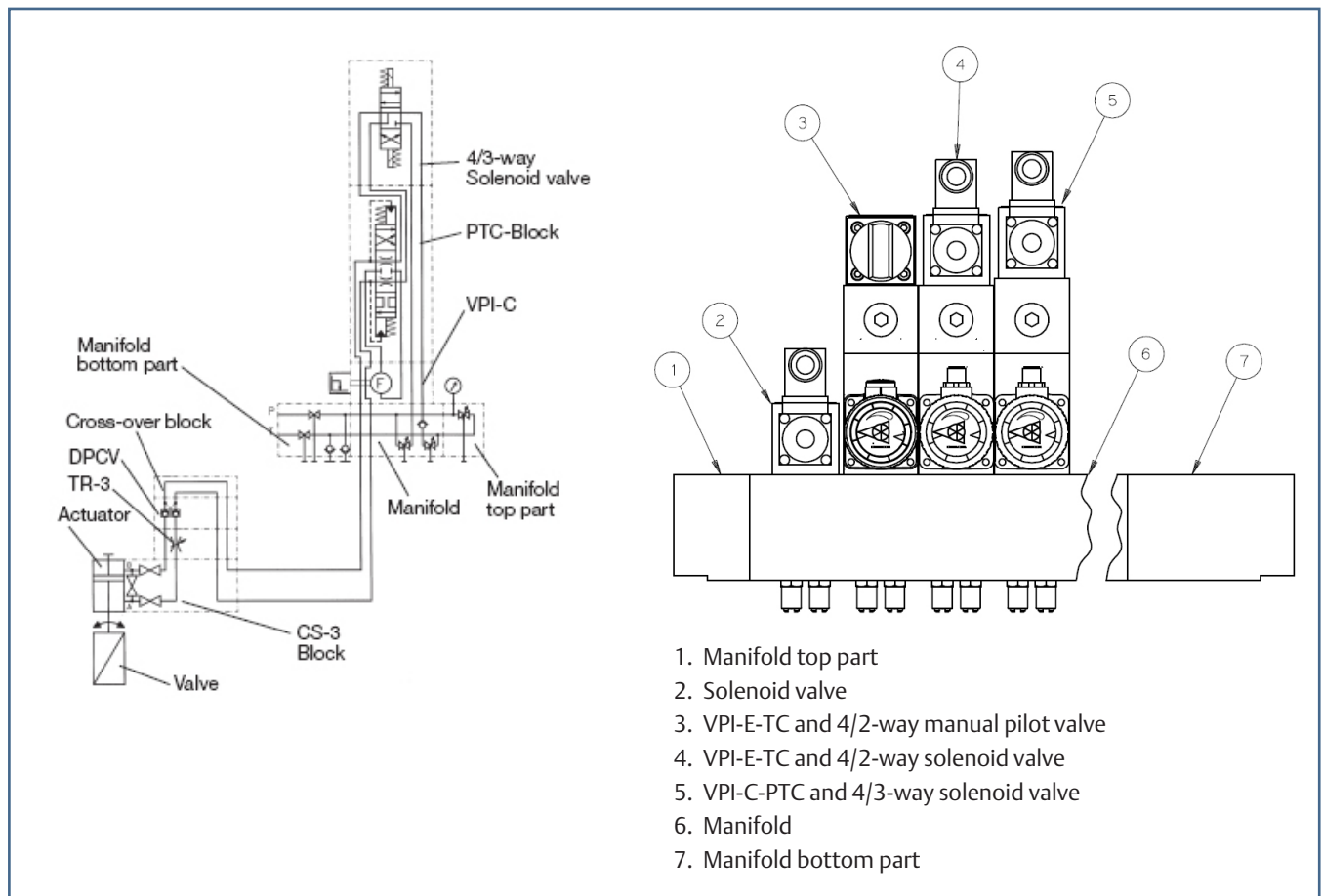

### VPI-V

This indicator is only used for visual indication of the valve position. It is normally used with TC-block and 4/2 way manual pilot valve. VPI-V can be used with PTC-block and 4/3 way valve.

### VPI-E

This indicator is used for visual and electric (ON/OFF) indication of the end positions of the valve (open/closed). The VPI-E is normally used with TC-block, but VPI-E can also be used with PTC-block. VPI-E is available with »normally open« switches, but can as a variant be supplied with »normally closed« switches.

### VPI-C

VPI-C can be used with PTC-block and 4/3 way valve, when the intermediate positions of the valve is required. VPI-C can also be used with TC-block and 4/2 way valve.

# VPI-C

## Signal Processing

For transforming the potentiometer signal into a standard 4 - 20 mA signal we recommend the PR.

- Isolation Amplifier 4114.
- Input configured to POTM.

Note that the VPI-C should always be used as a voltage-divider, with negligible current in the wiper.

## Terminal Layout

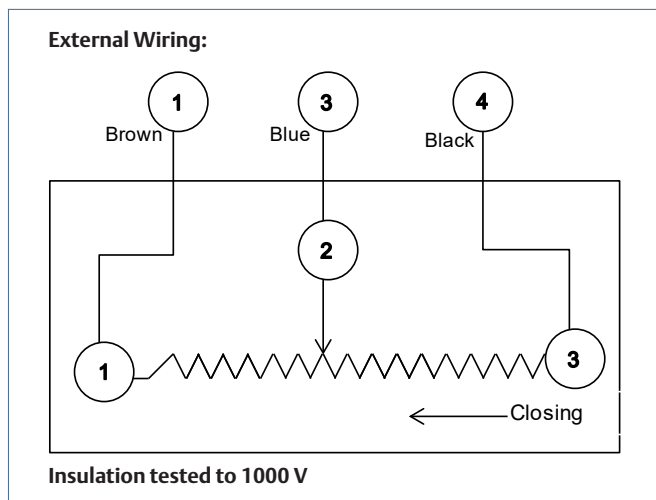

## Hook-up

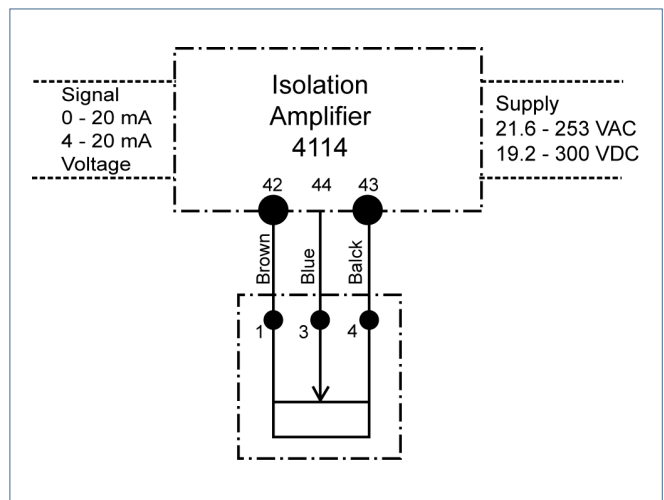

User Data	
Max. continuous load	0.2 W (VA)
Max. peak load	1 W (VA)
The normal approx. output range	15% in closed position and between 42% and 85% in open position.
The open position signal	is dependent on the choice of gear box size.
Standard Resistance Values	2 K $\Omega$
Total Resistance Tolerance	+/- 20%
Independent Linearity Tolerance	+ 5%
Resolution	Essentially infinite
Output smoothness	< 0.1%
Insulation Resistance	> 1.000 M $\Omega$ at 500 VDC
Dielectric Strength	1 min. at 500 VDC
Resistance Temp. Coefficient	+ 400 ppm / $^{\circ}$ C
Environmental Performances	
Operating Temp. Range	-25 $^{\circ}$ C to +85 $^{\circ}$ C
Vibration	10Hz to 2,000Hz 15G. Total resist. value var. < +2%

# VPI-E

## Terminal Layout

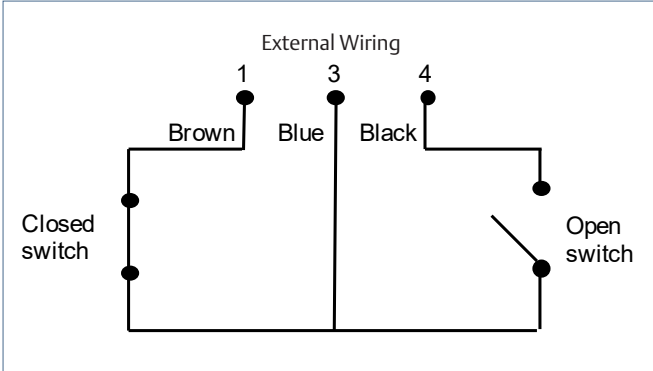

Switches shown in closed valve position. Max. cont. load 2.5 W. Insulation tested to 1000 V.

## Hook-up

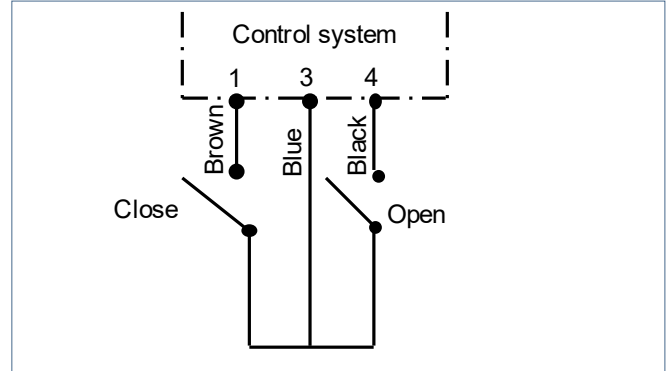

Computer, I.S. control or direct connected lamps or relays.

# DVPI-EE

## Hook-up

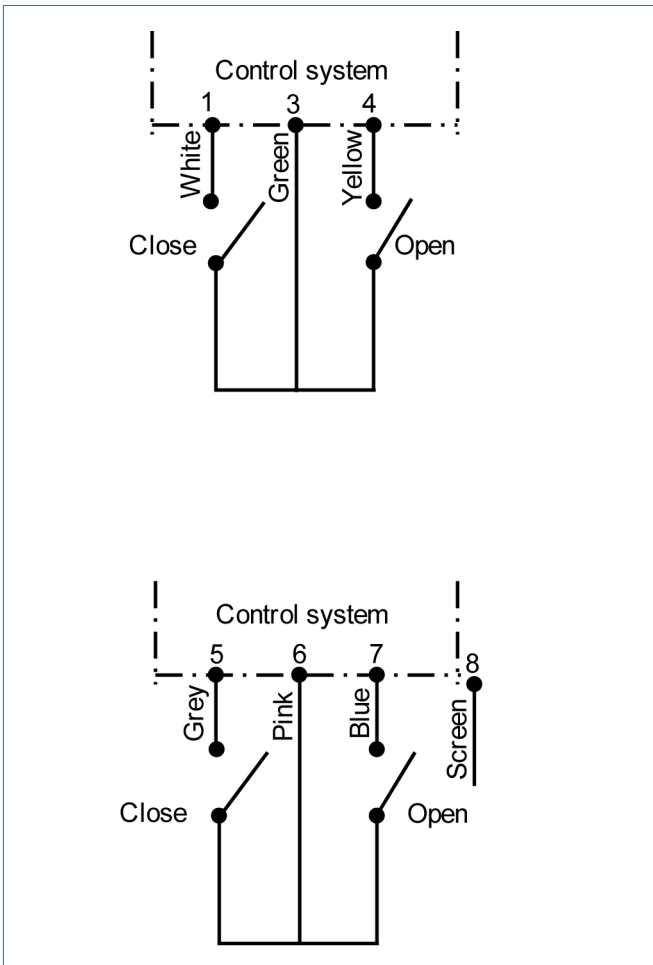

# DVPI-CE

## Hook-up

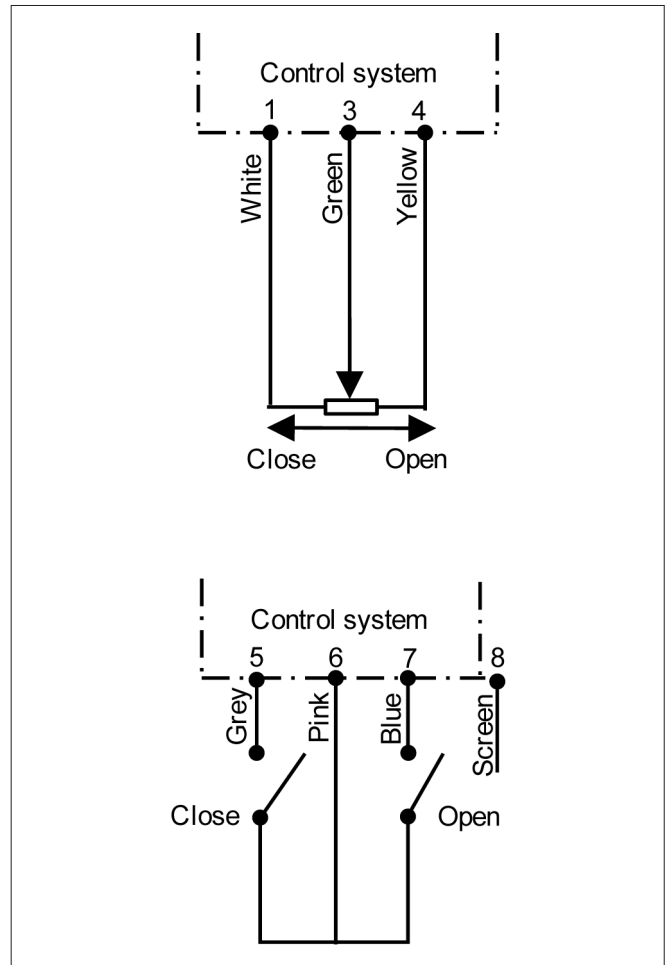

## Application

The VPI is designed to indicate the position of hydraulically actuated valves and the indicator arrow in the display will move from fully open to fully closed or vice versa when a volume equal to the actuator displacement passes through the unit.

Observe the min. and max. flows when dimensioning a hydraulic system including VPI indicators. Also observe the various factors influencing the accuracy and reliability of this in-direct position indication method.

Manufacturer's data of micro switches	
Contact material	Gold alloy X-point
Operating force	1.5 N
Electrical rating	100 mA / 60 VAC
Life expectancy	10 <sup>6</sup>
Max. temp	85°C

## Connection Plug Data

Standard cables are with hotmelt mounted plugs. Plugs delivered with VPI for spareparts accept  $\varnothing 4$  to  $\varnothing 8$  mm cable up to 1.5 mm<sup>2</sup>.

---

### About Emerson's Marine Solutions

Emerson is a world-leading provider of marine solutions with engineering excellence, decades of industry experience and global presence supporting any ship anywhere. All marine systems and solutions are designed especially for the harsh marine environments, engineered and manufactured in-house by our skilled teams of marine engineers. Emerson is well-known in the industry and has more than 50 years' experience with a large installed base and covers well-known marine brands such as Rosemount, Micro Motion and Damcos. Supporting marine customers from a global network of sales and service hubs along the maritime highway.

To learn more about Emerson's marine solutions, visit [Emerson.com/marine](https://www.emerson.com/marine)

To contact Emerson's marine experts, visit [Emerson.com/marinecontacts](https://www.emerson.com/marinecontacts)

The Emerson logo is trademark and service mark of Emerson Electric Co.  
The Rosemount, MicroMotion and Damcos logotypes are registered trademarks of one of the Emerson family of companies. All other marks are the property of their respective owners.

©2021 Emerson. All rights reserved.

