

DeltaV™ Virtualization Hardware

for Hyperconverged Infrastructure



The DeltaV™ Virtualization Hardware is fully tested and supported for virtual DeltaV solutions.

- Fully tested and supported hardware for DeltaV™ Virtualization with Hyperconverged Infrastructure (HCI)
- Configurations for both off-line and on-line control systems
- Easy, scalable, cost-effective with optimized performance
- Easy HCI cluster setup installation; ready to plug and play
- Software defined storage networks for high availability and automatic disaster recovery
- Supports single, dual, and quad monitors

Introduction

Emerson is committed to providing the same level of performance and reliability for DeltaV™ Virtualization environments that we provide in our traditional physical computer architecture. To ensure reliability and performance, we have rigorously tested virtual DeltaV systems with specific hardware components and configurations designed for real-time process control applications. With the new DeltaV Virtualization Hardware for Hyperconverged Infrastructure you can rest assured that your control system is fully tested and supported to meet your process control needs.

DeltaV Virtualization is available for both on-line and off-line applications. For off-line applications, we have software and hardware configurations ideal for development, testing, and training applications. For on-line applications, the new hyper converged infrastructure platform hardware offers built-in high availability and disaster recovery for servers and thin client networks. Regardless of the application, DeltaV Virtualization Hardware provides the platform you need to deliver the performance required.

Benefits

Fully tested and supported hardware for DeltaV

Virtualization: This ensures your virtual DeltaV system meets the rigorous requirements for process control applications. No surprises with third-party drivers, compatibility problems, or application performance.

Configurations for both offline and online control systems:

From standalone host servers to high availability blade servers with software defined storage, DeltaV Virtualization Hardware has it covered.

Easy, scalable, cost-effective with optimized performance:

DeltaV’s new integrated hardware platform for Hyperconverged Infrastructure, built on Dell’s PowerEdge R740xd XL, is designed for IT simplicity and delivers powerful performance. Out-of-box these servers with software defined storage are built for purpose, automation centered HCI solution for use with DeltaV Virtual Studio for Hyperconverged Infrastructure. Virtualization is even easier than ever.

Easy HCI cluster setup installation; ready to plug and play:

DeltaV Virtual Studio for Hyperconverged Infrastructure automates the setup of your HCI cluster. The DeltaV HCI host servers ship with the appropriate DeltaV control network cards preinstalled. Simply assign host networks using DeltaV Virtual Studio and you’re ready to connect to the DeltaV control network, Plant local area network (LAN), or client network.

Software defined storage networks for high availability:

Software defined storage in the Dell R740xd XL, provides fault

tolerant disk storage and supports automatic failover of virtual machines between DeltaV HCI host computers. Reliability and high availability is a must have for on-line virtualization solutions.

Supports single, dual, and quad monitors: DeltaV thin clients are available for single, dual and quad monitor operations using true multi-monitor communications.

Product Description

DeltaV virtualization requires specific hardware not found in traditional DeltaV systems. Consolidating multiple DeltaV workstations onto a common host means that hosts must have more computing capacity than traditional control system servers, specifically more CPU processing capacity and RAM memory. Client devices (for example thin clients) are required to provide a physical interface to the virtual DeltaV workstations.

Virtual environments improve productivity in development/training environments and with HCI you can take advantage of high availability options for on-line production environments. The hardware described in this document addresses these new requirements for DeltaV virtualization solutions.

DeltaV Virtualization host servers are available as part of an integrated HCI solution using the Dell PowerEdge R740xd XL.

An example of a DeltaV system for on-line virtualization with high availability is shown below.

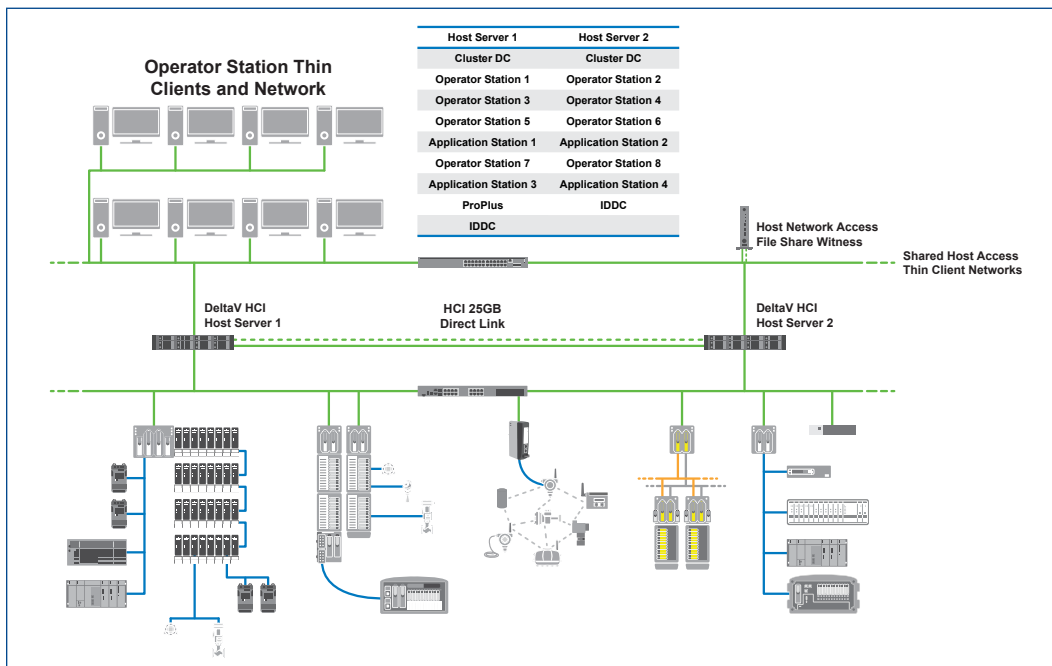

Resource Planning Guidelines

Virtual machines (VM) require host computer resources and are typically limited by available host processors (CPU) or random access memory (RAM). Table 1 provides guidelines on how many virtual machines to assign to host computers based on the VM loading and RAM requirements. VM Units (VMU) are used to estimate relative CPU loading and host limits.

These guidelines apply to the standard host server hardware as specified in this document.

Table 1 – Host VM Resource Planning

Host VM Resource Planning		
VM Class	VMUs	RAM (MB)
Workstation OS (e.g., Windows 10) <ul style="list-style-type: none"> DeltaV v14.3 and later DeltaV v13.3.1 and earlier 	1	8,192
	1	4,096
Server OS (e.g., Windows Server 2016) <ul style="list-style-type: none"> DeltaV v14.3 and later DeltaV v13.3.1 and earlier 	2	16,384
	2	8,192
Virtual Controllers (S, M, SZ)	0.5	256
Virtual PK Controller	0.8	1,024
Virtual Ethernet IO Card	0.8	256
Virtual CHARMS IO Card	0.5	64
Virtual CSLS and LSNB ¹	0.8	64
Supported Maximum VMU Limits for Host Servers ²		
On-line Host Server (R740xd XL) (Normal Operation)	24	
On-line Host Server (Temporary Failover Operation)	48	
Off-line Host Server (R650)	22	

Note 1 - For additional SIS VM limits, see product data sheet for DeltaV SIS with Electronic Marshalling – Virtual Simulation.

Note 2 - Total number of VMs should not exceed available CPU threads (=CPU cores x 2) - 1).

Integrated Virtualization Hardware

Designed specifically for virtualization, the integrated HCI hardware platform is a Dell PowerEdge R740xd XL built for purpose HCI servers configured for software defined storage and tested for use with DeltaV Virtual Studio for Hyperconverged Infrastructure.

The custom built R740xd XL for HCI is a highly reliable platform with redundant components for network storage, communications, power, and cooling. Managed repairs

can be performed with little or no virtual machine downtime, with automatic disaster recovery enabled during the repair process.

Integrated Hyperconverged Infrastructure Platform

1. Dell PowerEdge R740xd XL with 28 TB Storage Capacity (SE2751V1). Two of these custom built DeltaV HCI hosts are required for configuring the DeltaV HCI environment with software defined storage using Microsoft Storage Spaces Direct (S2D). A pair of DeltaV HCI hosts provide **26 TB of fully redundant** disk storage with twelve 2.4 TB drives. This size will support approximately 48 DeltaV virtual workstations.

Servers

1. Host Servers for Development, Test, and Training Systems (SE2753V1). These servers are Dell R650 series servers that include Windows Server 2022 standard operating systems so they can be run as a standalone server, without a separate management workstation. They include dual twelve-core CPUs with 192GB RAM. These servers come in rack-mounted form factor. This host server includes six 2.4 TB RAID 10 storage drive array to provide redundant storage protection for your VMs.

This server is ideal as a standalone host and can be used for offline applications using DeltaV Virtual Studio, or for off-line applications using VMware ESXi.

2. DeltaV Virtualization Domain Controller and Management Server (SE2752V1). This server can optionally be used to manage the host servers in the HCI cluster configuration. It may be used with DeltaV HCI host servers as an external domain controller and host management server. It can also be used to manage DeltaV VMs using DeltaV Virtual Studio. This server is a Dell R450 server with Windows Server 2022 standard operating system. This domain controller is separate from the DeltaV network and is not used to manage a DeltaV domain.

File Share Witness

File Share Witness Box. A file share witness in a Failover Cluster is used as a vote in a cluster quorum. The recommended File Share witness PC will reside on the Host Access Network. The redundant Host Access Network will coexist securely on the Thin Client Network switches using secure Virtual Local Access Network (VLANs).

The Host Access Network may be used to access the DeltaV HCI hosts, and the file share witness may run an instance of the DeltaV Virtual Studio in addition to other instances on the Domain Controller and DeltaV HCI Hosts. The File Share Witness can be a light weight Windows PC (i.e. WIN10 or Server OS) with redundant networks and must be a member of the DVS cluster domain. The health of witness machine is monitored as part of the overall DVS diagnostics.

Connectivity Kits

Connectivity kits for DeltaV HCI hosts connections **Direct Attach Cable Kit – DAC (SE2754-D)** is a pair of direct attach cable, 10m long with built in SFP connectors at each end of the cable. This kit is intended to be used to connect DeltaV HCI hosts and HCI switches when they are installed in the same location i.e., server rack or server room.

Short Range Transceiver Module Kit – Multimode (SE2754-MM) is a kit of four multimode 25GbE SFP28 Short Range (SR) transceiver modules. This kit is intended for use to connect DeltaV HCI hosts and HCI switches when they are located within a maximum distance of 100m of each other (for e.g., separate server cabinets in the same or different buildings).

Note – The fiber patch cable between the SFPs modules is not included in the kit.

Long Range Transceiver Module Kit – Single Mode (SE2754-SM) is a kit of four single mode 25GbE SFP28 Long Range (LR) transceiver modules. This kit is intended for use to connect DeltaV HCI hosts and HCI switches when they are located within a maximum distance of 10km of each other.

Note – The fiber cable between the SFPs modules is not included in the kit.

Thin Clients

Thin Client for Single, Dual, and Quad Monitors with Redundant Network (SE2549V5 /SE2550V1).

The thin client for DeltaV virtualization is available with Windows 10 IoT Enterprise operating system. It has been selected to meet the needs of on-line process control, including support for redundant thin client networks, with single, dual or quad monitors.

DeltaV virtualization also supports a hardened, rugged thin client for industrial or process environments with Pepperl+Fuchs (P+F) Industrial Box Thin Client (BTC12 and BTC14). The BTC14 supports up to four monitors, dual networks, and is DeltaV Virtual Studio “Ready” with preinstalled software. Contact P+F or your local Emerson office for more information.

Switches

DeltaV Switches for Thin Client, Host Access and HCI Storage Networks

High Bandwidth 25GbE Network Switches (SE6050V1)

are used when the HCI platform is scaled-up to more than 2 DeltaV HCI hosts. These switches are used to ensure performance and integrity of mission critical communication on the 4 HCI networks between the DeltaV HCI hosts. These are Dell S5212- ON 25GbE managed switches and are configured using the Switch Configuration Tool available with DeltaV Virtual Studio for Hyperconverged Infrastructure.

High Performance 1GbE Network Switches are used to ensure performance and integrity of mission critical communications between thin clients, HCI host servers, and the File Share Witness box. Starting with DVS v4.3, DeltaV Virtualization will support the option of using VLANs on non-core DeltaV networks – Host Access, Thin Client, Plant LAN. To take advantage of this new functionality, it is required to use the Hirschmann switches listed below.

(SE6049V1/SE6049V2): These are HIRSCHMANN Greyhound GRS105 managed switches with Layer 2 feature sets. DVS v4.3 & up will include a switch configuration guide for the setup and configuration of these switches with VLANs to support the shared Host Access and Thin Client Networks.

Unmanaged switches are appropriate for less critical operations such as development or training systems. The recommended and supported unmanaged switches for DeltaV virtualization are Netgear Prosafe switches, available in 24-, 16-, and 8-port configurations (JGS524, JGS516, GS116, GS108). These switches are intended for 1GbE communications for thin client, host access networks only. They are not supported for DeltaV primary and secondary ACN networks.

Note – The VLAN configuration for shared Host Access and Thin Client Networks is not supported on the unmanaged switches.

DeltaV Smart Switches are also available for the DeltaV virtualization 1GbE thin client network. DeltaV Smart Switches are managed by the DeltaV system with easy plug-and-play installation and minimal configuration. The smart switches also provide auto port lockdown for advanced network security. *See DeltaV Smart Switches product data sheet for additional information.*

Note – The VLAN configuration for shared Host Access and Thin Client Networks is not supported on the unmanaged switches.

SE2751V1 – Integrated Hyper Converged Infrastructure Platform General Specifications [based on Dell PowerEdge R740xd XL]

- Optimized chassis to consolidate compute, storage, and networking
- Chassis available in 2U rack-mountable form factor
- Sixteen dedicated 1GbE Ethernet ports through four 4-port NIC cards in PCI slots
- Two Intel E810-XXV Dual Port 10/25GbE SFP28
- One Dual Port 10GbE & Dual Port 1GbE
- Drives: Four 960-GB SSD SATA Mix Use 2.5in cache-drives
Twelve 2.4TB SAS 2.5in hard drives
- Two CPUs – Intel Xeon Gold 6248R 3.0GHz GHz 24 cores
- Memory: 512GB; Four Intel 128GB Optane Persistent Memory
- Server delivered with Windows Server 2022 Datacenter Edition operating system software
- Redundant, hot-swappable 1100W power supplies (1+1)
- No RAID
- iDRAC port for easy management of all resources (server nodes, storage, networking, and power)
- Efficient cooling with six performance fans
- Local power cord option
- USB Mouse and Keyboard included
- Rack configuration dimensions: 29" (73.0cm) D x 17.1" (43.4cm) W x 3.4" (8.6cm) H
- Rack configuration weight: 73 lbs. (33.1 kg), maximum configuration
- ReadyRails Sliding Rails with Cable Management Arm included in the box
- Five-year extended warranty with next business day parts replacement (For same day 4-hour parts replacement, contact your Dell representative)



For more information about R740xd XL chassis, see the PowerEdge R740xd Technical Guide on Dell.com.

*Notes – On-line Production systems using the DeltaV HCI Host Server (R740xd XL) require 2 of the above servers configured in an HCI Cluster to ensure system availability during upgrades or managed repairs and provide disaster recovery capabilities

Specifications Common to all Host Servers and Storage Units

It is the responsibility of the user to ensure their environment is compatible with G1. Due to compliance to RoHS requirements newer computers may not survive in the same environment as older models. If there is any chance of sulfur in the environment computers must be protected in environmental enclosures or relocated to a sulfur free environment.

Temperature: Operating 10° to 35°C (50° to 95°F), Storage -40° to 65°C (-40° to 149°F)

Relative Humidity: 20% to 80% (non-condensing)

Altitude: Operating -15.2 to 3048 m (-50 to 10,000 ft.), Storage -15.2 to 10,668 m (-50 to 35,000 ft.)

All computers must be installed in a dust-free, contaminant-free environment. These computers are not suitable for mounting in industrial environments unless they are mounted in enclosures that provide the necessary dust-free and contaminant-free environment. Environment must meet Class G1 level for airborne contaminants per the ISA standard ISA-71.04-1985, Environmental Conditions for Process Measurement and Control Systems: Airborne Contaminants.

Servers intended for embedded applications. 'Embedded application' means a software application that permanently resides in an industrial or consumer device, typically stored in a non-volatile memory such as read-only memory or flash memory. Server intended for use as appliances. 'Server appliance' means a server that is not intended to execute user-supplied software, delivers services through one of more networks, is typically managed through a web or command line interface and is bundled with a pre-installed OS and application software that is used to perform a dedicated function or set of tightly coupled functions.

SE2753V1 – Host Server for Development, Test, and Training Systems, Rack-mount General Specifications [based on Dell R650 server]

- 1U Rack-mountable chassis with sliding ready rails and cable management arm
- Eight Ethernet ports (Two Quad Port 1GbE PCIe ports)
- Two CPUs – Intel Xeon Gold 5317 3.0 GHz twelve cores
- Memory: 192GB
- Drives: Six 2.4TB SAS hard-drives in a RAID 10 Array, for 6 TB redundant disk storage
- Four USB ports – two back panel and two on front panel
- Hot-swappable drive backplane
- Redundant, hot-pluggable 1400W power supplies
- Local power cord option
- USB Mouse and Keyboard included
- Five-year extended warranty
- Server is delivered with Windows Server 2022 Standard Edition
- Five server CAL licenses included
- Compatible with DeltaV Virtual Studio v4.3

For DeltaV Virtual Studio v3.3.x & lower use Dell I R740 server (SE2715V07)



SE2752V1 – DeltaV Virtualization Domain Controller and Management Server [based on Dell R450]

- 1U Rack-mountable chassis with sliding ready rails and cable management arm
- Single CPU – Intel Xeon Silver 4309Y 2.8GHz, 8 cores, Turbo
- 16GB Memory
- Eight Ethernet ports (Two Quad Port 1GbE PCIe)
- Five USB ports - two back panel, two front panel, and one internal
- Cabled hard drive backplane
- Redundant, hot-pluggable 350W power supplies
- Two 960GB cabled SATA hard-drives in a RAID 1 Array for 960GB redundant disk storage
- RAID Controller included for improved performance
- Server is delivered with Windows Server 2022 Standard Edition
- Five server CAL licenses included
- DVD ROM drive
- USB mouse (two button w/ scroll)
- Local USB country keyboard
- Local power cord option
- Five-year extended warranty
- Compatible with DeltaV Virtual Studio v4.3.

For DeltaV Virtual Studio v3.3.x, use Dell R440 server (SE2713V03)



SE6050V1 – DeltaV Network Switch for HCI Networks General Specifications [Dell S5212F-ON]

- 25 Gigabit Ethernet, energy efficient switch
- 1U (half-width) Rack-mountable chassis with ReadyRails; 2x outer and 2x inner rail, 2 or 4 post racks
- Twelve 25GbE SFP28 ports
- Supports HCI networks
- Supports Connectivity kits - SE2754-D, SE2754-MM, SE2754-SM
- Dual internal redundant power supplies for high availability
- Five-year extended warranty
- Includes Qty. 8 of Dell Networking, Cable, SFP28 to SFP28, 25GbE Direct Attach Cable, 3 Meter

Note: For more detailed specifications, visit www.dell.com

Environmental

- Temperature Range: 32°F to 113°F (0°C to 45°C)
- Operating Relative Humidity: 5 - 90%
- Power Consumption: 304W Max



SE6049V1 – DeltaV Network Switch for Host Access and Thin Client Networks General Specifications [Hirschmann Greyhound GRS105-24TX/6SFP]

- One Gigabit Ethernet, energy efficient switch
- 1U Rack-mountable chassis
- 24 1Gb Ethernet ports (24x10/100/1000 Mbit TX)
- 6 SFP ports (6xGE/2.5GE SFP slots)
- Supports redundant shared host access and thin client networks
(Note – Switch configuration guide available with DVS v4.3)
- Dual internal redundant power supplies for high availability
- Local power cord options:
 - SE6049V1-P1 – U.S.A.
 - SE6049V1-P2 – European
 - SE6049V1-P3 – U.K.
 - SE6049V1-P4 – AU
- Compatible with SFP transceivers: VE6050T01, VE6050T02, VE6050T03, VE6050T07, VE6050T011
- Two year warranty



Note: For more detailed specifications, visit www.belden.com

Environmental

- Temperature Range: 14°F to 140°F (-10°C to +60°C)
- Operating Relative Humidity: 5-90%
- Power Consumption: 238W Max

SE6049V2 – DeltaV Network Switch for Host Access and Thin Client Networks General Specifications [Hirschmann Greyhound GRS105-16TX/14SFP]

- One Gigabit Ethernet, energy efficient switch
- 1U Rack-mountable chassis
- 16 1GbE Ethernet ports (16x10/100/1000 Mbit TX)
- 14 SFP ports (6x GE/2.5GE SFP slots + 8x GE SFP slots)
- Supports redundant shared host access and thin client networks
(Note – Switch configuration guide available with DVS v4.3)
- Dual internal redundant power supplies for high availability
- Local power cord options:
 - SE6049V2-P1 – U.S.A.
 - SE6049V2-P2 – European
 - SE6049V2-P3 – U.K.
 - SE6049V2-P4 – AU
- Compatible with SFP transceivers: VE6050T01, VE6050T02, VE6050T03, VE6050T07, VE6050T011
- Two year warranty



Note: For more detailed specifications, visit www.belden.com

Environmental

- Temperature Range: 14°F to 140°F (-10°C to +60°C)
- Operating Relative Humidity: 5-90%
- Power Consumption: 238W Max

SE2754 – Connectivity Kits for DeltaV HCI Hosts

SE2754-D – Direct Attach Cable Kit – DAC

- Dell Networking, Cable, SFP28 to SFP28, 25GbE, Active Optical (Optics Included), 10 Meter
- A kit contains 2 units of DAC



SE2754-MM – Short Range Transceiver Module Kit – Multimode

- Dell Networking, Transceiver, 25GbE SFP28 SR, MMF, Duplex LC
- A kit contains 4 SFPs. Optical Cable not included



SE2754-SM – Long Range Transceiver Module Kit – Single Mode

- Dell Networking, Transceiver, 25GbE SFP28 LR, SMF, Duplex LC
- A kit contains 4 SFPs. Optical Cable not included



SE2549V6 – DeltaV Thin Client for Single, Dual and Quad Monitors with Redundant Network [based on Amulet Hotkey DX1600]

- Thin clients used for DeltaV virtualization have been selected to meet the needs of on-line process control, including support for single, dual, and quad monitors, and support for redundant thin client networks
- AMD Ryzen V1605B (3.6GHz)
- Single, Dual, and Quad Monitor Support
- Memory: 8GB RAM
- Storage: 64GB eMMC
- 4 USB ports - 2x USB 3.1 Type-A
- 2x USB 3.1 Type-C
- 4x Display ports
 - Supports quad 4k monitor configuration
 - 4k resolution supported with DeltaV Live
- Windows 10 IoT Enterprise (Windows 10 IoT Enterprise 2016 LTSB) operating system for thin clients
- Dimensions: 230mm x 130mm x 42mm
- 12V DC inlet, proprietary locking connector
- Three-year warranty with ProSupport
- Pre-installed image with DeltaV Remote Desktop Client and recommended OS configuration
- Keyboard and mouse not included
- No internal speaker, external speakers required



Recovery media available for download on Guardian.

Please refer to Amulet Hotkey product data sheets for environmental and power consumption specifications.

SE2550V1 – DeltaV Thin Client for Single, Dual and Quad Monitors* with Redundant Network [based on Lenovo ThinkCentre M70q]

- Thin clients used for DeltaV virtualization have been selected to meet the needs of on-line process control, including support for single, dual, and quad monitors, and support for redundant thin client networks
- AMD Ryzen V1605B (3.6GHz)
- Single, Dual, and Quad Monitor* Support
- Memory: 8GB RAM
- Storage: 256GB SSD
- 6 USB ports – 4 x USB 3.1 Type-A
1x USB 3.1 Type-C
- 2 x Display ports
- Supports 4k monitor configuration
- 4k resolution supported with DeltaV Live
- Windows 10 IoT Enterprise (Windows 10 Enterprise 2021 LTSC) operating system for thin clients
- Dimensions: 179mm x 182mm x 36.5mm
- Local power cord option
- Three-year warranty
- Pre-installed image with DeltaV Remote Desktop Client and recommended OS configuration
- Built-in internal speakers
- Keyboard and Mouse not included

Recovery media available for download on Guardian.

*Note - For quad monitor display support, MST capable monitors are required e.g., ThinkVision P24q-30 Monitor available for purchase from Lenovo.

You can also use SE2819 - Dell 24" MST monitor

Please refer to Lenovo product data sheets for environmental and power consumption specifications.



Other Supported Thin Clients for DeltaV Virtualization

- Pepperl+Fuchs Industrial Box Thin Client BTC12 and BTC14
- Windows 10 IoT OS with P+F VisuNet RM Shell 5 or RM Shell 6 firmware installed and DeltaV Virtual Studio “ready”
- Supports up to four monitors with dual NIC cards for redundant thin client networks

For more information, lookup BTC12 and BTC14 on www.pepperl-fuchs.com

VE6055 – DeltaV USB to IP Converter General Specifications [SEH utnserver Pro]

- USB to IP Converter device for Windows OS
- Provides virtual machine access to DeltaV System ID USB access key (dongle) or other DeltaV access keys (for example Batch Analytics) through Ethernet connection
- Two USB 3.0 ports available
- Dimensions: 120 D x 84 W x 30 H (mm)
- Local power cord options:
 - VE6055P1 – U.S.A.
 - VE6055P2 – European
 - VE6055P3 – U.K.
 - VE6055P4 – JP



VE6055-R – DeltaV USB to IP Converter – Rack Mount General Specifications [SEH DongleServer Pro]

- USB to IP Converter device for Windows OS
- Provides virtual machine access to DeltaV System ID USB access key (dongle) or other DeltaV access keys (example Batch Analytics) through Ethernet connection
- Eight USB ports available
 - 4X USB 3.0 SuperSpeed ports
 - 4X USB 2.0 Hi-Speed ports
- Dimensions: 15 D x 155 W x 45 H (mm)
- Rack mount kit for 19" server racks
- Local power cord options:
 - VE6055P1-R – U.S.A.
 - VE6055P2-R – European
 - VE6055P3-R – U.K.
 - VE6055P4-R – JP



Other Supported Switches for Host Management and Thin Client Networks

Note: The VLAN configuration for shared Host Access and Thin Client Networks is not supported on these switches.

Managed Gigabit Switch

- HIRSCHMANN MACH104-20TX-FR, 24-port Gigabit Ethernet Managed Switch with redundant power
 - 24-port 10/100/1000 BASE-TX (RJ-45), Gigabit Ethernet managed rack-mountable switch
- HIRSCHMANN RS40, 9-port Gigabit Ethernet Managed Switch, DIN Rail Mounted, Fanless
 - 9 Gigabit ports: 5 x Twisted Pair ports RJ45 and 4 x Twisted Pair ports RJ45/SFP combo ports
 - Fiber uplink ports are available in multimode and/or single mode by using Gigabit or Fast Ethernet SFP transceivers

Unmanaged Gigabit Switches

- NETGEAR ProSafe Gigabit Switches
 - JGS524 – 24-port 10/100/1000BASE-T (RJ-45) Gigabit Ethernet unmanaged desktop or rack-mountable switch
 - JGS516 – 16-port 10/100/1000BASE-T (RJ-45) Gigabit Ethernet unmanaged desktop or rack-mountable switch
 - GS116 – 16-port 10/100/1000 Gigabit Ethernet unmanaged desktop switch
 - GS108 – eight-port 10/100/1000 Gigabit Ethernet unmanaged desktop switch

©2023, Emerson. All rights reserved.

The Emerson logo is a trademark and service mark of Emerson Electric Co. The DeltaV logo is a mark of one of the Emerson family of companies. All other marks are the property of their respective owners.

The contents of this publication are presented for informational purposes only, and while diligent efforts were made to ensure their accuracy, they are not to be construed as warranties or guarantees, express or implied, regarding the products or services described herein or their use or applicability. All sales are governed by our terms and conditions, which are available on request. We reserve the right to modify or improve the designs or specifications of our products at any time without notice.

Contact Us

www.emerson.com/contactus