

Spring return actuator with High Flow Plate

Increase the cycle speed of spring return actuators

Description:

The High Flow Plate is a simple means to increase the cycle speed (and reduce the cycle time) on single acting (spring return) pneumatic actuators.

Cycle speed:

In general pneumatic rack & pinion actuators are equipped with large internal air porting that allows adequate cycling under normal circumstances.

On the other hand, the 1/4" solenoid valves or pneumatic fitting materials, limit the maximum speed potential of the actuator due to the orifice diameter. Under normal operation conditions, the achieved cycle speed is sufficient.

If faster cycle times are required (<0.5 or <1 seconds) 1/4" solenoid valves or pneumatic fitting material can become a problem. These components will, in this case, function as a throttle, reducing the potential maximum air flow and as such the maximum cycle speed.

The High Flow Plate solves this problem. High Flow plates can be supplied with 1/2" air connections to allow the fitting of larger solenoid valves and pneumatic fitting material.

Construction:

The High Flow Plate is a aluminum plate which can be mounted directly to solenoid interface on actuators which are designed according VDI/VDE 3845 (NAMUR). The plate is supplied with fasteners and seals.

The customer side of the plate is equipped with 1/2" or 3/4" NPT or BSP air connections for piped solenoid control.

Specifications:

Materials:

- 1 Block: Aluminium alloy, black anodized (10-15µm)
- 2 Fasteners: Stainless steel
- 3 O-ring seals: NBR Rubber

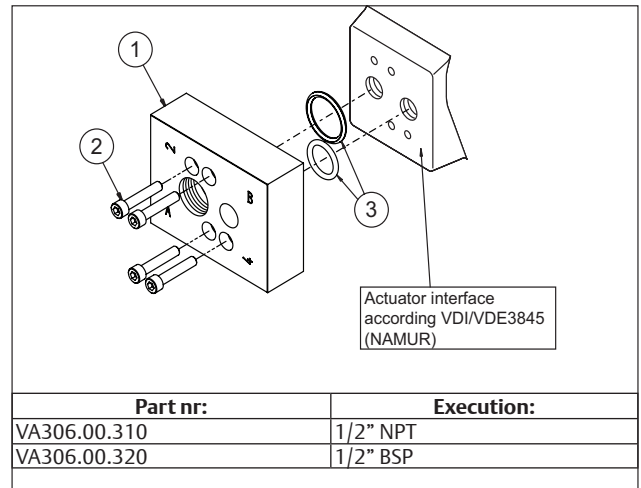

Note:

- 1 The High Flow Plate on its own does not make the cycle time of an actuator quicker. Take care that there is sufficient air supply capacity at actuator:
 - Air supply capacity must be larger than the Cv or Kv value of the control solenoid valve.
 - Use tubing with sufficient large diameter.
 - Make tubing from the main air supply to the actuator as short as possible.
- 2 For the largest size actuators enlarging the port to the central air chamber to 1/2" can be considered to achieve the required cycle speed.
- 3 Consider the use of Quick Exhaust valves in combination with these High Flow Plates.
- 4 In general the actuators life cycle is reduced when cycling very fast.
 - For valves that cycle not that often, the total life cycle will still be sufficient.
 - For applications with increased cycle speed, that do cycle often, external limit stops (bottom stop plate) are recommended, especially on the larger size actuators.

Please consult your nearest HYTORK representative for more detailed information.

Product Data sheet

D190 Rev 0 Page 2 of 2
October 2017

Hytork XL

Dimensions:

Dimension	1/2"	
in:	mm	Inch
A	63.5	2.50
B	82	3.23
C	25.4	1.00
D	32	1.26
E	25	0.98
F	16	0.63
G	29	1.14
H	12	0.47
J	27	1.06
K	1.27	0.05
L	1/2"BSP	1/2"NPT
M	1/4"BSP	1/4"NPT

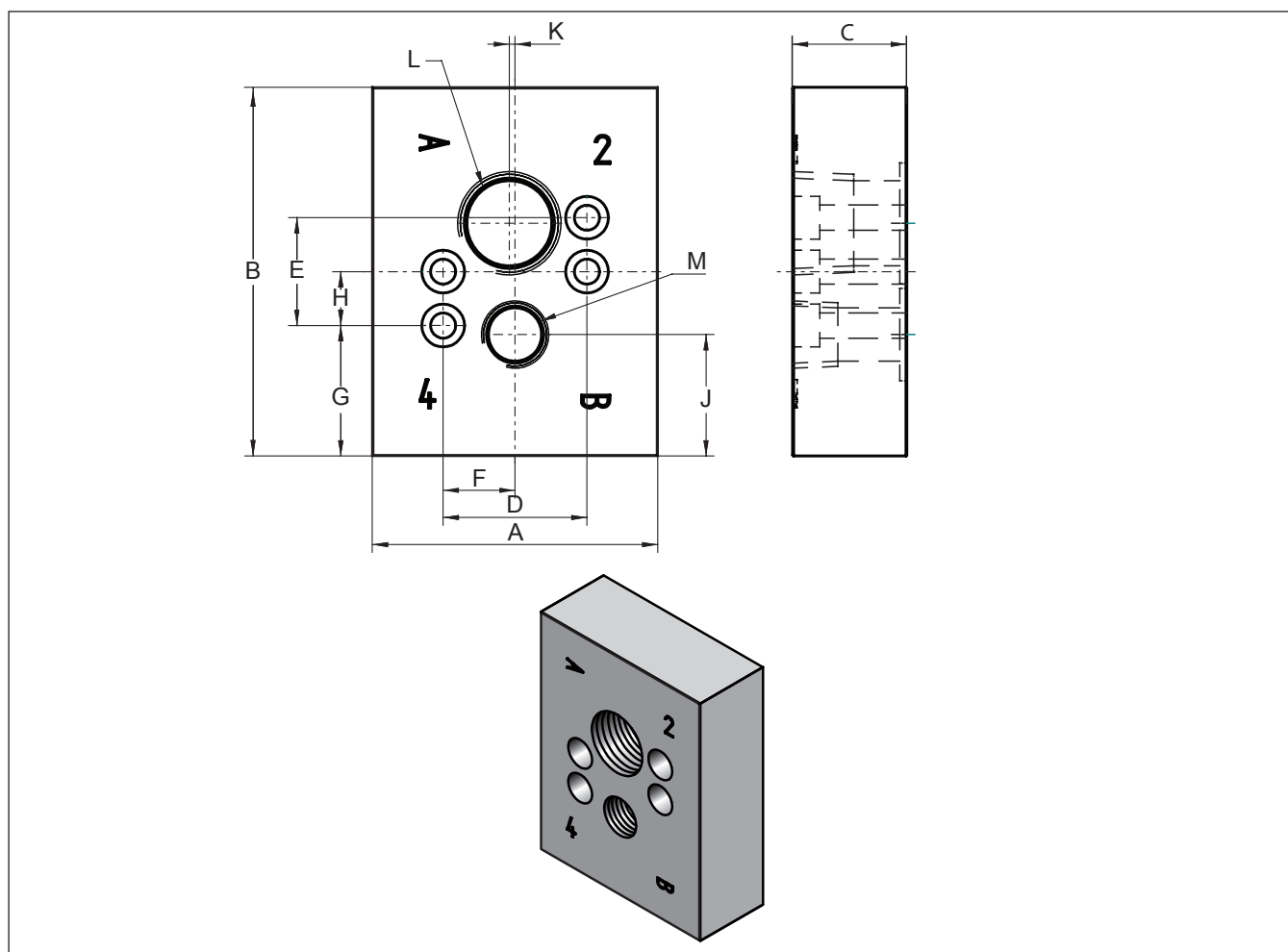

HYTORK™

EMERSON™

Copyright © Emerson. The information in this document is subject to change without notice. Updated data sheets can be obtained from our website www.emerson.com/eim or from your Emerson Automation Solutions - Actuation Technologies Center:
America's: +1 281 477 4100 Europe: +36 22 53 0950 Asia/Pacific: +65 67 77 8211