

Micro Motion™ 5700 Transmitters



Repeatable, reliable, accurate measurements

- Faster processing speed delivers the best response even in the most challenging applications such as meter proving, filling & dosing, and batching
- Smart Meter Verification™ provides you with the confidence you need in your meter performance
- Zero verification confirms the calibration and indicates when it's time to re-zero the meter
- Approved for custody transfer and certified for SIL2 and SIL3, which provides measurement confidence and reliability

A window into your process

- Easy access to detailed measurement history gives you valuable insight into your process for better troubleshooting and optimization
- Real-time indication of multi-phase flow events allow for greater process control
- High-accuracy density measurement reduces or eliminates waste in your process while the embedded historian records upsets and process deviations

Productivity solutions with 5700 transmitters

- Designed to minimize the time and expertise needed to install and operate the flow meter
- Configurable I/O version, provides up to five fully configurable input/output channels that can be easily upgraded with changing needs
- Ethernet version includes multiple protocols on dual channels, plus a configurable I/O channel
- PROFIBUS®-PA version includes PROFIBUS-PA output, a fixed mA Output channel, and a configurable Frequency/Discrete Output channel
- FOUNDATION™ Fieldbus version includes IEC-61158-2 FOUNDATION Fieldbus output, a fixed mA Output channel, and a configurable Frequency/Discrete Output channel
- Intrinsically safe output version, includes up to four configurable intrinsically safe output channels that can easily be upgraded with changing needs
- Offline configuration and auditing through new file shuttling capability
- Wi-Fi display option enables point-to-point wireless communication in order to configure and characterize the meter, download historical files, and run Smart Meter Verification for troubleshooting purposes.

Note

Available for a 5700 with configurable inputs and outputs only.

- Marine Bunkering Software option
The MID-certified bunker application enables the 5700 to work as a central unit for an MID-approved bunker system. This application captures two phase flow during a bunker measurement and handles multiple inputs and outputs from pressure, temperature, liquid detectors, and ticket printers.

Micro Motion 5700 transmitters

The 5700 transmitters deliver the best measurement technology and offer unparalleled support – ensuring total measurement confidence, valuable process insight and greater operational efficiency. These transmitters provide the scalability, compatibility and performance that your application demands.

Simplified installation and commissioning

An intuitive interface, spacious side-access wiring compartment and convenient mounting brackets.



Smart Meter Verification: advanced diagnostics for your entire system

Our online tool verifies that your meter performs as well as the day it was installed, giving you assurance in less than 90 seconds.



Measurement history for easier troubleshooting and optimization

Detailed history files deliver key time-stamped information about your process from configuration changes and alerts to process events and statistics.

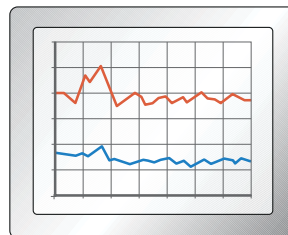

Unmatched system connectivity and services interfaces

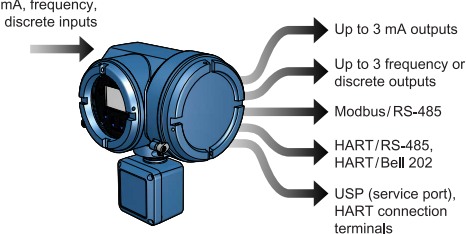
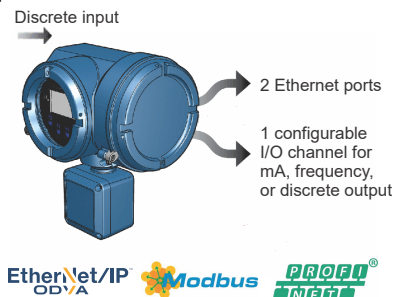
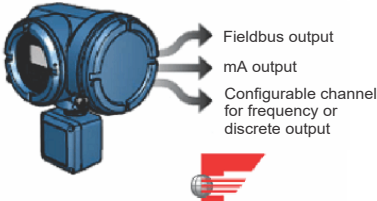
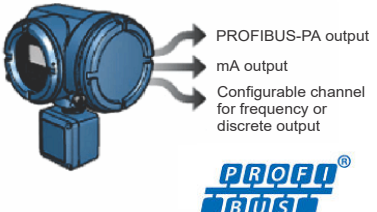
<p>Configurable I/O version</p>	<p>Up to five fully configurable I/O channels with multiple mA, Discrete and Frequency Outputs, and several powerful service interfaces.</p> 
<p>Ethernet version</p>	<p>Two Ethernet outputs with EtherNet/IP®, Modbus® TCP, or PROFINET® — plus one configurable output.</p> 
<p>FOUNDATION Fieldbus version</p>	<p>FOUNDATION Fieldbus output, mA Output, and a configurable channel for Frequency or Discrete Output.</p> 
<p>PROFIBUS-PA version</p>	<p>PROFIBUS-PA output, mA Output, and a configurable channel for Frequency or Discrete Output.</p> 

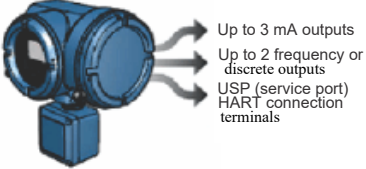
Intrinsically safe outputs version	<p>Up to four fully configurable output channels with up to three mA, and two Discrete and Frequency Outputs.</p> 
------------------------------------	--

Access information when you need it with asset tags

Newly shipped devices include a unique QR code asset tag that enables you to access serialized information directly from the device. With this capability, you can:

- Access device drawings, diagrams, technical documentation, and troubleshooting information in your MyEmerson account
- Improve mean time to repair and maintain efficiency
- Ensure confidence that you have located the correct device
- Eliminate the time-consuming process of locating and transcribing nameplates to view asset information

5700 enhancements

Internal memory

The 5700 transmitter provides a backup of:

- Manually-saved transmitter configurations
- Meter verification baseline and history
- Data log
- Licensing key

Note

If you need to replace your transmitter, move your old memory to the new transmitter without losing any data or licensing information.

Software licensing

Software licensing makes it possible to:

- Purchase permanent features and add them later
- Trial features, such as concentration measurement, for 60 days before buying
- Order up to 5 input/output channels through the license

Large graphical display

- Supports multiple languages
- Supports full configuration capabilities directly from the display
- Provides understandable alert codes

Two-phase flow detection

Two-phase flow detection provides clear, concise information about fluid conditions, including notification about the following fluid regimes:

- Single phase
- Moderate two-phase flow
- Severe two-phase flow

Physical design

- Conduit and terminal compartments are accessible from the sides
- Modular board stack design
- Spacious wiring compartments
- Remote mounting bracket
- A Universal Service Port (USP) connects and transfers data using standard, easily available equipment

Troubleshooting tools

The 5700 transmitter stores data in non volatile memory with Real Time Clock, including:

- Audit trail
- Alert log
- Long term data historian: 5-minute Min, Max, Avg, Std Dev (10 years)
- Short term data historian: 1-second data (30 days)

Note

The 5700 transmitter contains descriptive alerts describing the issue and recommended steps for resolution.

- Follows NE 107 Standard

Wi-Fi display option (5700 with configurable inputs and outputs only)

Wi-Fi display option enables point-to-point wireless communication in order to configure and characterize the meter, download historical files, and run Smart Meter Verification for troubleshooting purposes.

The maximum Wi-Fi connection distance is 115 ft (35 m) from the front display and 50 ft (15 m) from the sides and back of the transmitter housing.

Spectrum approvals for Wi-Fi

US and Canada (FCC and ISED)
Europe (ETSI)

Table 1: Uses following RF module: Trade Name -- Silicon Labs

Options	Type			
Model Number	M15SB			
FCC ID	XF6-M15SB			
Frequency Range	2402 ~ 2480 MHz			
	Zigbee: 2405 MHz ~ 2480 MHz			
Operate Freq. Band	Frequency Range (MHz)	Modulation	Channel Bandwidth	Data Rate 400 GI (ns)
IEEE 802.11b	2412 ~ 2462	DSSS	20 MHz	Up to 11 Mbps
IEEE 802.11g	2412 ~ 2462	OFDM	20 MHz	Up to 54 Mbps
IEEE 802.11n 2.4 GHz 20MHz	2412 ~ 2462	OFDM	20 MHz	Up to 72.2 Mbps
IEEE 802.11n 2.4 GHz 40 MHz	2412 ~ 2462	OFDM	40 MHz	Up to 150 Mbps
Antenna Information	Model	Type	Connector	Max. Gain (dBi)
	RSIA15	PCB Trace Antenna	Internal	0.99
	WS.01.B.305151	Heavy Duty Screw Mount Antenna	SMA Reverse	4.1

Table 2: Max. EIRP

Power setting 1_Antenna Type: PCB Trace Antenna	Power setting 1_Antenna Type: PCB Trace Antenna
IEEE 802.11b	19.98 dBm
IEEE 802.11g	19.57 dBm
IEEE 802.11n 2.4 GHz 20 MHz	19.71 dBm
IEEE 802.11n 2.4 GHz 40 MHz	19.71 dBm

Modulations

There are 3 types of modulation schemes: DSSS, OFDM, OFDM (256 QAM). Specify all as modulation type changes based on mode of operation.

Block Diagram

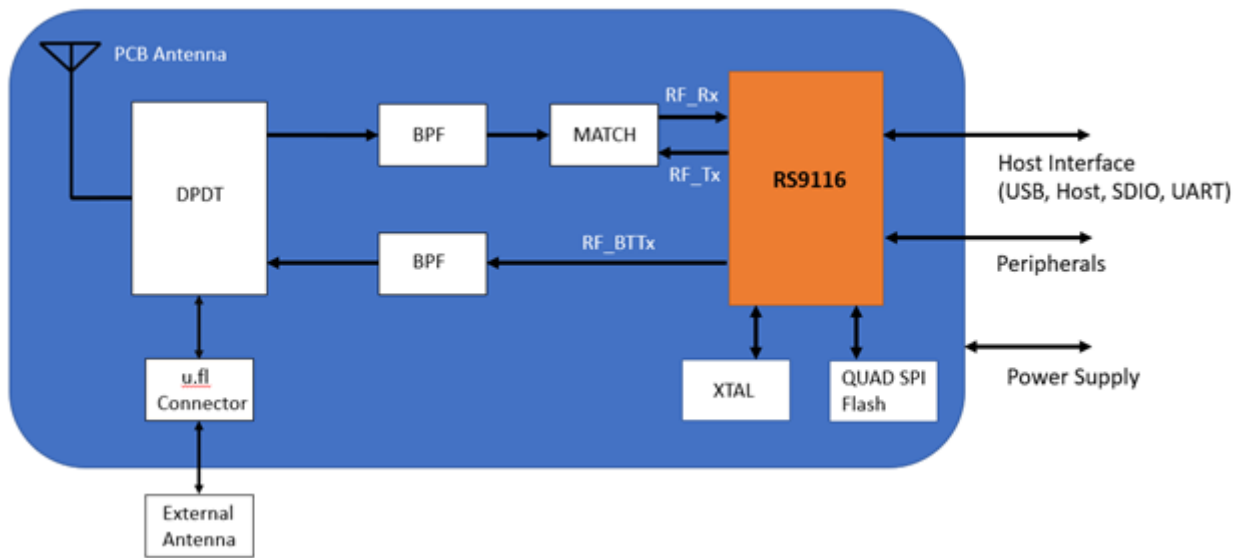

Applications

Applications are custom designed programs and software that offer additional functionality and performance to transmitters. These applications are available through options in the transmitter model code. For details, see the [Ordering information](#) section.

Smart Meter Verification

Provides a quick, complete assessment of a Micro Motion Coriolis Meter, determining whether the meter has been affected by erosion, corrosion, or other influences affecting meter calibration. No secondary references are required to perform this operation, and the meter can continue normal process measurement while the test is in progress.

Smart Meter Verification Professional on the 5700 transmitter also offers non-uniform coating detection, installation verification, detection of optimal flow range, and two-phase flow detection. A 90-day trial version is included with all transmitters with enhanced core processors. After the 90-day trial, a basic version of Smart Meter Verification will provide simple pass/fail results, and simple diagnostics that run without interrupting your processes.

Discrete batch control

- Simple batch control based on totalizer values
- Frequency Output configured as Discrete Output for transmitters with analog or intrinsically safe outputs
- Automatic overshoot compensation
- Single and dual stage batching available on the configurable I/O and intrinsically safe versions when ordered with the Batching Software (BS) package option
- Optional constant batch mode provides a simplified batch screen flow, and stays in this mode until a password is entered to exit mode, in addition to standard batch
- Batch ticket printing available if Channel E is enabled (supports Terminal Window, Generic, Epson TM88v, Epson TMU-295 and Digitec 6610A printers)
- Batch ticket printing available with Ethernet (supports Epson TM88VI)

Note

Discrete batch control is not available with 5700 FOUNDATION Fieldbus or PROFIBUS-PA.

Petroleum measurement and API correction option

- Accepts inputs from temperature and pressure devices
- Calculates values as per May, 2004 API MPMS Chapter 11.1 Tables A, B, C, D, and Chapter 11.2.4 Table E.
 - Relative density (specific gravity and API gravity) at reference temperature from observed density and temperature
 - Volume corrected to reference temperature and pressure
- Calculates flow-weighted average temperature and flow-weighted average observed density (specific gravity and API gravity)

Concentration measurement

Provides concentration measurement based on either industry-specific or liquid-specific units and relationships. Standard measurement options include:

- Industry-specific:
 - °Brix
 - °Plato
 - °Balling
 - °Baumé at SG60/60
 - Specific gravity

- Liquid-specific:
 - %HFCS
 - Concentration derived from reference density
 - Concentration derived from specific gravity

Note

Additionally, the application can be customized for site-specific concentration measurement (such as %HNO₃, %NaOH).

Advanced Phase Measurement

- Accurately measures liquid or gas flow in limited multiple-phase conditions
 - Immediate and continuous access to production or process data
 - Real time reporting of Gas Void Fraction (GVF)
- Facilitates reliable measurement at a fraction of the cost of true multi-phase meters
 - Historian automatically captures all production data
 - Little to no maintenance or calibration
- Combines with Net Oil Computer (NOC) or concentration measurement to measure two liquids in the presence of gas
 - Provides single-well and multi-well real-time Net Oil and Net Water measurements
 - Improves concentration measurement in processes with intermittent entrained gas

Piecewise Linearization (PWL) for enhanced gas applications

- Provides gas calibration enhancement capability for industry-leading gas measurement performance
- Designed specifically for midstream natural gas fiscal metering applications

Note

Piecewise Linearization is not available with 5700 FOUNDATION Fieldbus.

Third-party gas calibration services are not included.

Related information

[Ordering information](#)

Electrical connections

Electrical isolation

For all 5700 versions, each I/O channel is isolated +/-50VDC from all other outputs and earth ground.

Configurable I/O version

Connection	Description
Input/Output	Up to 5 pairs of wiring terminals for transmitter I/O and communications
Power	<ul style="list-style-type: none"> ■ One pair of wiring terminals accepts AC or DC power ■ One internal ground lug for power-supply ground wiring
Sensor	<ul style="list-style-type: none"> ■ 4-wire remote mount – 4 terminals for connection to 4-wire sensor ■ 9-wire remote mount – 9 terminals for connection to 9-wire sensor
Service port (HART®)	Two clips for temporary connection to the service port
Universal Service Port (USP)	A USP connected to commercially-available USB equipment and cables
Wi-Fi display option	<p>Wi-Fi display option enables point-to-point wireless communication in order to configure and characterize the meter, download historical files, and run Smart Meter Verification for troubleshooting purposes.</p> <p>The maximum Wi-Fi connection distance is 115 ft (35 m) from the front display and 50 ft (15 m) from the sides and back of the transmitter housing.</p>

Ethernet version

Connection	Description
Ethernet ports	Two Ethernet ports for EtherNet/IP, Modbus TCP, PROFINET, and web server connections
Input/Output	One configurable channel for mA Output, Frequency Output, Discrete Output, or Discrete Input
Power	<ul style="list-style-type: none"> ■ One pair of wiring terminals accepts AC or DC power ■ One internal ground lug for power-supply ground wiring
Sensor	<ul style="list-style-type: none"> ■ 4-wire remote mount – 4 terminals for connection to 4-wire sensor ■ 9-wire remote mount – 9 terminals for connection to 9-wire sensor
Universal Service Port (USP)	A USP connected to commercially-available USB equipment and cables
Embedded web server	<ul style="list-style-type: none"> ■ Connects to embedded web server via Ethernet connection for on-board configuration or data transfer ■ Supports secure web server connection with default Self-Signed Certificate and optional support for Certificate Authority

FOUNDATION Fieldbus version or PROFIBUS-PA version

Connection	Description
Input/Output	<ul style="list-style-type: none"> ■ One channel for mA Output ■ One configurable channel for Frequency Output or Discrete Output These outputs are available as intrinsically safe, or non-intrinsically safe, based on the output option selected. For PROFIBUS-PA, the outputs are intrinsically safe if powered with an intrinsically safe power supply.
Power	<ul style="list-style-type: none"> ■ One pair of wiring terminals accepts AC or DC power ■ One internal ground lug for power-supply ground wiring
Sensor	<ul style="list-style-type: none"> ■ 4-wire remote mount – 4 terminals for connection to 4-wire sensor ■ 9-wire remote mount – 9 terminals for connection to 9-wire sensor
Universal Service Port (USP)	A USP connected to commercially-available USB equipment and cables
FOUNDATION Fieldbus	Two clips for a temporary connection to the service port
PROFIBUS-PA	Two terminals for connection

Intrinsically safe outputs version

Connection	Description
Output	Up to 4 pairs of wiring terminals for transmitter outputs and communications
Power	<ul style="list-style-type: none"> ■ One pair of wiring terminals accepts AC or DC power ■ One internal ground lug for power-supply ground wiring
Sensor	<ul style="list-style-type: none"> ■ 4-wire remote mount – 4 terminals for connection to 4-wire sensor ■ 9-wire remote mount – 9 terminals for connection to 9-wire sensor
Service port (HART)	Two clips for temporary connection to the service port
Universal Service Port (USP)	A USP connected to commercially-available USB equipment and cables

Note

- Each screw terminal connection accepts one or two solid conductors, 24 AWG (0.205 mm²) to 12 AWG (3.31 mm²) or one or two stranded conductors, 22 AWG (0.326 mm²) to 14 AWG (2.08 mm²). Each plug type connector accepts one stranded or solid conductor, 24 AWG (0.205 mm²) to 12 AWG (3.31 mm²).
- For integral mount transmitters (mounting code I), the connection between the transmitter and the sensor is not normally accessed.

Input/output signal detail

Configurable I/O channels (output board code A)

Signal	Channel A		Channel B		Channel C		Channel D		Channel E	
Wiring terminals	1	2	3	4	5	6	7	8	9	10
mA inputs and outputs	mA output 1 (HART®)		mA output 2		mA output 3		mA input		RS-485	
Frequency outputs	N/A		Frequency output 2 ⁽¹⁾		Frequency output 1		Frequency output 2 ⁽¹⁾		N/A	
Discrete outputs	N/A		Discrete output 1		Discrete output 2		Discrete output 3		N/A	
Discrete inputs	N/A		N/A		Discrete input 1		Discrete input 2		N/A	
Frequency inputs	N/A		N/A		N/A		Frequency input		N/A	

(1) Frequency output 2 can be mapped to Channel B or D. For multiple frequency outputs, use Frequency 1 on Channel C and Frequency 2 on either Channel B or D.

Ethernet channels (output board code C)

Signal	Channel A	Channel B	Channel C
Channel options	EtherNet/IP The same protocol must be ordered on both Channel A and B. ProLink™ III and the Integrated Web server can always be connected to either Channel A or B.	EtherNet/IP	mA output
	Modbus TCP	Modbus TCP	Frequency output
	PROFINET	PROFINET	Discrete output
	N/A	N/A	Discrete input

FOUNDATION Fieldbus channels (output board code E with Channel A assignment F for intrinsically safe H1 outputs)

Signal	Channel A		x		Channel B		Channel C		x	
Wiring terminal	1	2	3	4	5	6	7	8	9	10
Channel options	FOUNDATION Fieldbus (FISCO "ia" or FISCO "ic")		x		IS mA output		IS Frequency output		x	
							IS Discrete output			

FOUNDATION Fieldbus channels (output board code N with H1 outputs)

Signal	Channel A		x		Channel B		Channel C		x	
Wiring terminal	1	2	3	4	5	6	7	8	9	10
Channel options	FOUNDATION Fieldbus (FISCO "ia" or FISCO "ic")		x		IS mA output		IS Frequency output		x	
							IS Discrete output			

PROFIBUS-PA (output board E with Channel A assignment G)

Signal	Channel A		x		Channel B		Channel C		x	
Wiring terminal	1	2	3	4	5	6	7	8	9	10
Channel options ⁽¹⁾	PROFIBUS-PA		x		IS mA output		IS Frequency output		x	
							IS Discrete output			

(1) The outputs for Channels B and C are intrinsically safe if powered with an intrinsically safe power supply.

Intrinsically safe output channels

Signal	Channel A		Channel B		Channel C		Channel D	
Wiring terminals	1	2	3	4	5	6	7	8
mA outputs	mA output (1) (HART)		mA output (2)		mA output (3)		N/A	
Frequency outputs	N/A		N/A		Frequency output (1)		Frequency output (2)	
Discrete outputs	N/A		N/A		Discrete output (1)		Discrete output (2)	

Channel A specifications

Configurable I/O (output board code A)

Specification	mA output
Downscale fault	Configurable from 1.0 – 3.6 mA, default value = 2.0 mA
External voltage (passive power)	Maximum: 30VDC Maximum loop resistance: 1080 ohm @ 30VDC
Internal voltage (active power)	Nominal: 24VDC
Linearity	0.015 % span, span = 16mA
Scalable range	4-20 mA
Upscale fault	Configurable from 21.0 – 23.0 mA, default value = 22.0 mA

Note

mA Output is linear with process from 3.8 to 20.5 mA, per NAMUR NE 43 (February 2003).

Ethernet (output board code C)

Specifications:

- 10BASE-T
- 100BASE-TX

FOUNDATION Fieldbus (output board code E with Channel A assignment F)

Specifications:

- FOUNDATION Fieldbus H1 output
- Wiring is intrinsically safe with intrinsically safe power supply
- Transmitter fieldbus circuit is passive, and draws power from the fieldbus segment — current draw is 13 mA
- Manchester encoded digital signal conforms to IEC 61158-2

FOUNDATION Fieldbus (output board code N)

Specifications:

- FOUNDATION Fieldbus H1 output
- FOUNDATION Fieldbus wiring is non-incendive
- Transmitter fieldbus circuit is passive, and draws power from the fieldbus segment — current draw is 13 mA
- Manchester encoded digital signal conforms to IEC 61158-2

PROFIBUS-PA (output board code E with Channel A assignment G)

- PROFIBUS-PA output
- Wiring is intrinsically safe with intrinsically safe power supply
- Transmitter fieldbus circuit is passive, and draws power from the fieldbus segment — current draw is 13 mA
- Manchester encoded digital signal conforms to IEC 61158-2

Intrinsically safe (output board code D)

Specification	mA output
Downscale fault	Configurable from 3.2 – 3.6 mA, default value = 3.2 mA
Entity parameters	$U_i = 30V$ $I_i = 484mA$ $P_i = 2.05W$ $C_i = 150pF$ $L_i = OuH$
External voltage (passive power)	Minimum: 8VDC Maximum: 30VDC Maximum loop resistance: 917 ohm @ 30VDC
Linearity	0.020 % span, span = 16 mA
Scalable range	4-20mA
Upscale fault	Configurable from 21.0 – 23.0 mA, default value = 22.0mA

Channel B specifications

Configurable I/O (output board code A)

Specification	mA output	Frequency output (2)	Discrete output (1)
Internal voltage (active power)	Nominal: 24VDC Maximum loop resistance: 820 ohm	Nominal: 24VDC Sourcing: 22 mA	Nominal: 24VDC Sourcing: 7 mA sourcing
External voltage (passive power)	Maximum: 30VDC Maximum loop resistance: 1080 ohm @ 30VDC	Maximum: 30VDC Maximum sinking: 500 mA	Maximum: 30VDC Maximum sinking: 500 mA
Scalable range	4-20mA	0.01 Hz – 10 kHz	N/A
Downscale fault	Configurable from 1.0 – 3.6 mA, default value = 2.0 mA	0Hz	N/A
Upscale fault	Configurable from 21.0 – 23.0 mA, default value = 22.0 mA	Configurable from 10 Hz to 14.5 kHz, default value = 14.5 kHz	N/A
Linearity	0.015 % span, span = 16mA	Output is linear with flow rate to 12.5 kHz	N/A
Resolution	N/A	± 1 pulse	N/A

Ethernet (output board code C)

Specifications:

- 10BASE-T
- 100BASE-TX

FOUNDATION Fieldbus (output board code E with Channel A assignment F) or PROFIBUS-PA (output board code E with Channel A assignment G)

Specification	mA output
External voltage (passive power)	Minimum: 10VDC Maximum: 30VDC Maximum loop resistance: 869 ohms @ 30V
Scalable range	4-20 mA
Downscale fault	Configurable from 1.0 – 3.6 mA, default value = 2.0 mA
Upscale fault	Configurable from 21.0 – 23.0 mA, default value = 22.0 mA
Linearity	0.015 % span, span = 16 mA
Entity parameters	U _i = 30V I _i = 484mA P _i = 2.05W C _i = 0.27nF L _i = 5uH

FOUNDATION Fieldbus output board code N

Specification	mA output
External voltage (passive power)	Minimum: 10VDC Maximum: 30VDC Maximum loop resistance: 869 ohms @ 30V
Scalable range	4-20 mA
Downscale fault	Configurable from 1.0 – 3.6 mA, default value = 2.0 mA
Upscale fault	Configurable from 21.0 – 23.0 mA, default value = 22.0 mA
Linearity	0.015 % span, span = 16 mA

Note

mA Output is linear with process from 3.8 to 20.5 mA, per NAMUR NE-43 (February 2003).

Intrinsically safe (output board code D)

Specification	mA output
External voltage (passive power)	Minimum: 8VDC Maximum: 30VDC Maximum loop resistance: 917 ohm @ 30VDC
Scalable range	4-20mA
Downscale fault	Configurable from 3.2 – 3.6 mA, default value = 3.2 mA
Upscale fault	Configurable from 21.0 – 23.0 mA, default value = 22.0 mA
Linearity	0.020 % span, span = 16mA

Channel C specifications**Configurable I/O (output board code A) and Ethernet (output board code C)**

Specification	mA output	Frequency output ⁽¹⁾	Discrete output ⁽²⁾	Discrete input
Internal voltage (active power)	Nominal: 24VDC Maximum loop resistance: 820 ohm	Nominal: 24VDC Sourcing: 22 mA	Nominal: 24VDC Sourcing: 7 mA	Nominal: 24VDC Sourcing: 7 mA
External voltage (passive power)	Maximum: 30VDC Maximum loop resistance: 1080 ohm @ 30VDC	Maximum: 30VDC Maximum sinking: 500 mA	Maximum: 30VDC Maximum sinking: 500 mA	Maximum: 30VDC
Scalable range	4-20 mA	0.01 Hz – 10 kHz	N/A	N/A
Downscale fault	Configurable from 1.0 – 3.6 mA, default value = 2.0 mA	0Hz	N/A	N/A
Upscale fault	Configurable from 21.0 – 23.0 mA, default value = 22.0 mA	Configurable from 10 Hz to 14.5 kHz, default value = 14.5 kHz	N/A	N/A
Resolution	N/A	± 1 pulse	N/A	N/A

Specification	mA output	Frequency output ⁽¹⁾	Discrete output ⁽²⁾	Discrete input
Linearity	0.015 % span, span = 16 mA	Output is linear with flow rate to 12.5 kHz	N/A	N/A
Maximum positive threshold	N/A	N/A	N/A	3VDC
Minimum negative threshold	N/A	N/A	N/A	0.6VDC

- (1) Load resistor (500 Ω resistance recommended for 24V supply.) Use the following equations for other load resistance values: $R_{max} = [(V_{supply} - 6V) / 0.003] - R_{barrier}$ (maximum value of load resistor allowed) $R_{min} = 0$ ohms
(2) $Current = (V_{supply} - 0.8V) / (1690 \text{ ohms} + barrier \text{ internal resistance in ohms} + load \text{ resistor in ohms})$

Note

mA Output is linear with process from 3.8 to 20.5 mA, per NAMUR NE-43 (February 2003).

FOUNDATION Fieldbus (output board code E with Channel A assignment F) or PROFIBUS-PA (output board code E with Channel A assignment G)

Specification	Frequency output ⁽¹⁾	Discrete output ⁽²⁾
External voltage (passive power)	Maximum: 30VDC Minimum: 8VDC	Maximum: 30VDC Minimum: 8VDC
Scalable range	0.01 Hz - 10 kHz	N/A
Downscale fault	0Hz	N/A
Upscale fault	Configurable from 10 Hz to 14.5 kHz, default value = 14.5 kHz	N/A
Resolution	± 1 pulse	N/A
Entity parameters	$U_i = 30V$ $I_i = 484mA$ $P_i = 2.05W$ $C_i = 11.27nF$ $L_i = 5uH$	N/A

- (1) Load resistor (500 Ω resistance recommended for 24V supply.) Use the following equations for other load resistance values: $R_{max} = [(V_{supply} - 6V) / 0.003] - R_{barrier}$ (maximum value of load resistor allowed) $R_{min} = 0$ ohms
(2) $Current = (V_{supply} - 0.8V) / (1690 \text{ ohms} + barrier \text{ internal resistance in ohms} + load \text{ resistor in ohms})$

FOUNDATION Fieldbus (output code N)

Specification	Frequency output ⁽¹⁾	Discrete output ⁽²⁾
External voltage (passive power)	Maximum: 30VDC Minimum: 8VDC ⁽³⁾	Maximum: 30VDC Minimum: 8VDC ⁽⁴⁾
Scalable range	0.01 Hz - 10 kHz	N/A
Downscale fault	0Hz	N/A
Upscale fault	Configurable from 10 Hz to 14.5 kHz, default value = 14.5 kHz	N/A
Resolution	± 1 pulse	N/A

- (1) Load resistor (500 Ω resistance recommended for 24V supply.) Use the following equations for other load resistance values: $R_{max} = [(V_{supply} - 6V) / 0.003] - R_{barrier}$ (maximum value of load resistor allowed) $R_{min} = 0$ ohms
(2) $Current = (V_{supply} - 0.8V) / (1690 \text{ ohms} + barrier \text{ internal resistance in ohms} + load \text{ resistor in ohms})$
(3) Load resistor (500 Ω resistance recommended for 24V supply.) Use the following equations for other load resistance values: $R_{max} = [(V_{supply} - 6V) / 0.003]$ (maximum value of load resistor allowed) $R_{min} = 250$ ohms (minimum value of load resistance required)
(4) $Current = (V_{supply} - 0.8V) / (1690 \text{ ohms} + load \text{ resistor in ohms})$

Intrinsically safe (output board code D)

Specification	mA output	Frequency output ⁽¹⁾	Discrete output
External voltage (passive power)	Maximum: 30VDC Maximum: 30VDC Maximum loop resistance: 917 ohm @ 30VDC	Maximum: 30VDC	Maximum: 30VDC
Scalable range	4-20 mA	0.01 Hz – 10 kHz	N/A
Downscale fault	Configurable from 3.2 – 3.6 mA, default value = 3.2 mA	0Hz	N/A
Upscale fault	Configurable from 21.0 – 23.0 mA, default value = 22.0 mA	Configurable from 10 Hz to 14.5 kHz, default value = 14.5 kHz	N/A
Accuracy	N/A	± 1 pulse	N/A
Linearity	0.015 % span, span = 16mA	Output is linear with flow rate to 12.5 kHz	N/A

(1) Load resistor (500 Ω resistance recommended for 24V supply.)

Note

mA Output is linear with process from 3.8 to 20.5 mA, per NAMUR NE-43 (February 2003).

Channel D specifications

Channel D specifications do not apply to Ethernet, FOUNDATION Fieldbus, or PROFIBUS-PA configurations.

Configurable I/O (output board code A)

Specification	Frequency output (2)	mA input	Discrete output (3)	Discrete input (2)	Frequency input
Internal voltage (active power)	Nominal: 24VDC 2.21 kilo ohm pull-up resistor	Nominal: 24VDC	Nominal: 24VDC 2.21 kilo ohm pull-up resistor	Nominal: 24VDC 2.21 kilo ohm pull-up resistor	Nominal: 24VDC 2.21 kilo ohm pull-up resistor
External voltage (passive power)	Maximum: 30VDC Maximum sinking: 500mA	Maximum: 30VDC	Maximum: 30VDC Maximum sinking: 500 mA	Maximum: 30VDC	Maximum: 30VDC
Scalable range	0.01 Hz – 10 kHz	4 - 20 mA Fault indication if mA Input drops below 3.8 mA or goes above 20.5 mA	N/A	N/A	N/A
Downscale fault	0Hz	N/A	N/A	N/A	N/A
Upscale fault	Configurable from 10 Hz to 14.5 kHz, default value = 14.5 kHz	N/A	N/A	N/A	N/A
Accuracy	+/- 1 pulse	N/A	N/A	N/A	N/A
Input resistance	N/A	100 ohm	N/A	N/A	N/A

Specification	Frequency output (2)	mA input	Discrete output (3)	Discrete input (2)	Frequency input
Max frequency	N/A	N/A	N/A	100 Hz	3500 Hz
Maximum positive threshold	N/A	N/A	N/A	3VDC	3VDC
Minimum negative threshold	N/A	N/A	N/A	0.6VDC	0.6VDC

Intrinsically safe (output board code D)

Specification	Frequency output (2)	Discrete output (2)
External voltage (passive power)	Maximum: 30VDC	Maximum: 30VDC
Scalable range	0.01 Hz - 10 kHz	N/A
Downscale fault	0Hz	N/A
Upscale fault	Configurable from 10 Hz to 14.5 kHz, default value = 14.5 kHz	N/A
Accuracy	± 1 pulse	N/A

Channel E specifications

Channel E is not available for Ethernet, FOUNDATION fieldbus, Intrinsically safe, or PROFIBUS-PA configurations.

Output option	Specification
Configurable I/O (output board code A)	RS-485 Modbus

Sensor input mounting codes

Mounting codes	Description
I (integral mount)	Integrally mounted to sensor, no external input connection
C (9-wire remote mount)	One 9-wire sensor signal input connection, intrinsically safe
R (4-wire remote mount)	One 4-wire sensor signal input connection, intrinsically safe

Digital communications

Protocols	Outputs and descriptions
Modbus/USP	<ul style="list-style-type: none"> ■ One service port that can be used for a temporary connection only ■ Connects to a PC via USB as if the transmitter had a built-in USB/RS-485 converter ■ Supports all Modbus data rates ■ Requires a USB A/male-to-A/male cable <ul style="list-style-type: none"> — A 4 ft (1.22 m) cable is supplied with each meter
Modbus/RS-485,HART/RS-485	<ul style="list-style-type: none"> ■ Available on Channel E, if purchased ■ One RS-485 output can be used for direct connection to HART or Modbus host systems ■ Accepts data rates between 1200 baud and 38.4 kilobaud ■ 115.2 kilobaud is also available as a special order item ■ Uses the latest HART 7 standard
HART/Bell 202	<ul style="list-style-type: none"> ■ Available on Channel A, if purchased ■ HART Bell 202 signal is superimposed on the primary milliamp output, and is available for host system interface ■ Requires 250 to 600 ohms load resistance ■ Uses the latest HART 7 standard
FOUNDATION Fieldbus	<ul style="list-style-type: none"> ■ Available on Channel A ■ Models/output codes: <ul style="list-style-type: none"> — 5700 with output code E is FISCO “ia” certified in Zone 1 / Div 1 and is FISCO “ic” certified in Zone 2 / Div 2 (formerly known as FNICO) — 5700 with output code N ■ Transmitters are registered with the Fieldbus Foundation, and conform to the FOUNDATION Fieldbus H1 protocol specification. ■ FISCO: <ul style="list-style-type: none"> — Field device in compliance with EN 60079-11:2012 and IEC 60076-11:2011 — $U_i = 33\text{ V}$, $I_i = 380\text{ mA}$, $P_i = 5.32\text{ W}$, $C_i = 0.27\text{ nF}$, $L_i = 5\text{ }\mu\text{H}$

Protocols	Outputs and descriptions
EtherNet/IP/Ethernet	<ul style="list-style-type: none"> ■ Available on Channel A and Channel B ■ Supports Auto Negotiate with data rates of 10 MB and 100 MB and half and full duplex ■ Supports Auto Detect of Ethernet Crossover cables ■ Supports Dynamic Host Configuration Protocol (DHCP) ■ Supports Device Level Ring (DLR) ■ Supports Address Conflict Detection (ACD) ■ Supports Quality of Service (QoS) ■ Supports file object for EDS download ■ Conforms to ODVA EtherNet/IP Specification CT 12 ■ Conforms to the 10BASE-T and 100BASE-TX Ethernet standards ■ Supports secure web server connection with default Self-Signed Certificate and optional support for Certificate Authority
Modbus TCP/Ethernet	<ul style="list-style-type: none"> ■ Available on Channel A and Channel B ■ Supports Auto Negotiate with data rates of 10 MB and 100 MB and half and full duplex ■ Supports Auto Detect of Ethernet Crossover cables ■ Supports Dynamic Host Configuration Protocol (DHCP) ■ Uses v1.1b of the Modbus TCP standard ■ Conforms to the 10BASE-T and 100BASE-TX Ethernet standards ■ Supports secure web server connection with default Self-Signed Certificate and optional support for Certificate Authority
PROFINET/Ethernet	<ul style="list-style-type: none"> ■ Available on Channel A and Channel B ■ Supports Auto Negotiate with data rates of 10 MB and 100 MB and half and full duplex ■ Supports Auto Detect of Ethernet Crossover cables ■ Conforms to Conformance Class A v2.31 standard ■ Conforms to the 10BASE-T and 100BASE-TX Ethernet standards ■ Supports secure web server connection with default Self-Signed Certificate and optional support for Certificate Authority
PROFIBUS-PA	<ul style="list-style-type: none"> ■ Available on Channel A ■ Transmitters are registered with the Profibus Organization, and fulfill the requirements of the PROFIBUS-PA Profile 3.02 for Process Control Devices. ■ Compatible with all PROFIBUS-PA host systems ■ FISCO: <ul style="list-style-type: none"> — Field device in compliance with EN 60079-11:2012 and IEC 60076-11:2011 — $U_i = 33\text{ V}$, $I_i = 380\text{ mA}$, $P_i = 5.32\text{ W}$, $C_i = 0.27\text{ nF}$, $L_i = 5\text{ }\mu\text{H}$

The 5700 with FOUNDATION Fieldbus support

Fieldbus software functionality

The 5700 FOUNDATION Fieldbus software is designed to permit remote testing and configuration of the transmitter using the DeltaV™ Fieldbus Configuration Tool, or other FOUNDATION Fieldbus compliant hosts. The Coriolis sensor signal is channeled through the flowmeter to the control room and the FOUNDATION Fieldbus configuration device.

Function block overview

Function block type	Quantity	Execution time (milliseconds)
Analog Input (AI)	4	14
Analog Output (AO)	2	14
Discrete Input (DI)	1	13
Discrete Output (DO)	1	12
Integration (INT)	2	12
Proportional, Integral, Derivative (PID)	1	13

Transducer blocks

Transducer blocks hold data from the Coriolis sensor, including process variables, configuration, calibration, and diagnostics.

The 5700 transmitter with FOUNDATION Fieldbus provides up to 7 transducer blocks:

- Measurement - For process and diagnostic variables and configuration of process parameters.
- Device - For device, display, channels configuration and device alert information
- Device Totals and Inventories - For configuration of device totals and inventories
- Meter Verification - For Smart Meter Verification
- API referral - For petroleum measurement calculations using API MPMS Chapter 11.1
- Concentration Measurement - For complex density and concentration calculations (e.g., %HFCS, SG60/60)
- APM - For Advance Phase Measurement and NOC calculations

Resource block

The resource block contains physical device information, including available memory, manufacturer identification, type of device, and features.

Analog Input function blocks

The Analog Input (AI) function block processes the measurement from the Coriolis sensor and makes it available to other function blocks. It also allows filtering, alarm handling, and engineering unit changes. Each of the 4 5700 AI blocks can be assigned to one of 27 available variables. There are 4 permanent Analog Input function blocks.

Analog Output function blocks

The AO function block assigns an output value to a field device through a specified channel. The block supports mode control, signal status calculation, and simulation. The AO block can report pressure from an external pressure source, temperature from an external temperature source, or watercut from an external device. There are 2 permanent analog output function blocks.

Discrete Input function block

One permanent Discrete Input (DI) function block can be assigned to any of the Discrete Input variable channels in the transducer block. The DI block channels are: forward/reverse indication, zero in progress, fault condition indication, and meter verification failure.

Discrete Output function block

One permanent Discrete Output (DO) function block can be assigned to any of the Discrete Output variable channels in the transducer block. The DO block channels are: Start Sensor Zero, Increment CM Curve, Start Meter Verification in Continuous Measurement Mode, Reset All Process Totals, Start/Stop All Totals, Reset Config Totals 1-7.

Proportional integral derivative function block

One permanent Proportional Integral Derivative (PID) function block combines all the necessary logic to perform proportional/integral/derivative control. The block supports mode control, signal scaling and limiting, feed forward control, override tracking, alarm limit detection, and signal status propagation.

Integrator function block

Two permanent Integrator (INT) function blocks provides functionality for the transmitter totalizers. Any of 7 internal totals or any of 7 internal inventories can be selected and reset.

Diagnostics and service

5700 transmitters automatically perform continuous self diagnostics. Using the Device transducer block, the user can perform on-line testing of the transmitter and sensor. Diagnostics are event driven and do not require polling for access.

PlantWeb™ Field Diagnostic is supported. The diagnostic information is based on NAMUR NE 107 standard.

The 5700 with PROFIBUS-PA support

The 5700 PROFIBUS-PA software is in compliance with the PROFIBUS PA Profile for Process Control Devices version 3.02. The transmitter software supports Coriolis Flow profile with 3-AI + 1-TOT profile (PA Profile 139742) in a profile-specific configuration, while in the manufacturer-specific profile (0E8B), the transmitter supports 4-AI + 4-TOT + 2-AO + 1-DI + 1-DO function blocks.

- The transmitter supports condensed status for function block implementation
- The device has adaptation mode for ident selection to simplify device configuration with host
- The transmitter has hardware as well as software addressing capability
- All Totalizer Function Blocks could output and control device internal totals or inventories for more accurate measurement
- Device diagnostics information is based on NAMUR NE 107

Power supply

- Complies with Low Voltage Directive 2014/35/EU per IEC 61010-1 Ed. 3.0 2010-06; Over voltage Category II, Pollution Degree 2
- For European installations, install a switch or circuit breaker that is suitably located and easily reached. Mark the switch or circuit breaker as the disconnecting device for the transmitter, in compliance with the Low Voltage Directive 2014/35/EU.

Type	Value
AC power	<ul style="list-style-type: none"> 85 to 240 VAC, 50/60 Hz 6 watts typical, 11 watts maximum
DC power	<ul style="list-style-type: none"> 18 to 100 VDC 6 watts typical, 11 watts maximum Size the length and diameter of power conductors to provide 18VDC minimum at the power terminals at a load current of 0.7A
Fuse	1.5A Slow Blow (UL 248-14)

Environmental limits

Ambient temperature limits

Type	Temperature
Operating	-40 °F (-40.0 °C) to 149 °F (65.0 °C)
Storage	-40 °F (-40.0 °C) to 185 °F (85.0 °C)

Note

The display can lose visibility below -22 °F (-30.0 °C).

Vibration limits

Meets IEC 60068-2-6, endurance sweep, 5 to 2000 Hz up to 1.0 g.

Humidity limits

The humidity limits are 5 to 95% relative humidity, non-condensing at 140 °F (60.0 °C).

Environmental effects

EMI effects

Complies with:

- EMC directive 2014/30/EU
- NAMUR NE-21 (09.05.2012)

Ambient temperature effect

Ambient temperature effect on mA Outputs shall not exceed:

Configurable I/O version	±0.0025% of span per degree C
Ethernet version	±0.0025% of span per degree C
FOUNDATION Fieldbus or PROFIBUS-PA version	±0.005% of span per degree C
Intrinsically safe outputs version	±0.005% of span per degree C

Hazardous area classifications

CSA and CSA-US

- Ambient temperature is limited to -40 °F (-40.0 °C) to 149 °F (65.0 °C) for CSA compliance. Temperature code T4 is for Division 2 installations and T6 is for Division 1 installations.
- Class I, Div. 1, Groups C and D. Class II, Div. 1, Groups E, F, and G explosion proof (when installed with approved conduit seals). Otherwise, Class I, Div. 2, Groups A, B, C, and D.
- Provides nonincendive sensor outputs for use in Class I, Div. 2, Groups A, B, C, and D; or intrinsically safe sensor outputs for use in Class I, Div. 1, Groups C and D or Class II, Div. 1, Groups E, F, and G.

Code	Description
AA	Class I, Div. 1, Groups C and D. Class I, Div. 2, groups A,B,C,D Class II, Div. 1, Groups E, F, and G explosion proof (when installed with approved conduit seals).
2A	Class I, Div. 2, Groups A, B, C, and D.

IECEX

Ambient temperature range is -40 °F (-40.0 °C) to 149 °F (65.0 °C) for IECEx compliance.

Configurable I/O — ordering code A

Note

For EA and 3A approval codes, the marking will change when installed with Smart Wireless 775 THUM.

Classification	Approval code	Approval	
Flameproof	IA	Standard or Wi-Fi IIB display	Ex db [ib] IIB+H ₂ T6 Gb
		No display, standard IIC, or Wi-Fi IIC display	Ex db [ib] IIC T6 Gb
		Dust marking	Ex tb [ib] IIIC T75 °C Db IP66/IP67
Flameproof/Increased safety	EA	Standard or Wi-Fi IIB display	Ex db eb [ib] IIB+ H ₂ T6 Gb
		No display, standard IIC, or Wi-Fi IIC display	Ex db eb [ib] IIC T6 Gb
		Dust marking	Ex tb [ib] IIIC T75 °C Db IP66/IP67

Classification	Approval code	Approval	
Non sparking with an integral transmitter on the sensor	3A	Standard or Wi-Fi IIB display	Ex nA nC IIB+H ₂ T4 Gc
		No display, standard IIC, or Wi-Fi IIC	Ex nA nC IIC T4 Gc
		Dust marking	Ex tc IIIC T75 °C Dc IP66/IP67
Non sparking with a remote transmitter on the sensor	3A	Standard or Wi-Fi IIB display	Ex nA nC [ib Gb] IIB+H ₂ T4 Gc
		No display, standard IIC, or Wi-Fi IIC	Ex nA nC [ib Gb] IIC T4 Gc
		Dust marking	Ex tc [ib Db] IIIC T75 °C Dc IP66/IP67

Ethernet — ordering code C

Classification	Approval code	Approval	
Flameproof	IA	Standard display	Ex db [ib] IIB+H ₂ T6 Gb
		No display or IIC display	Ex db [ib] IIC T6 Gb
		Dust marking	Ex tb [ib] IIIC T75 °C Db IP66/IP67
Non sparking with an integral transmitter on the sensor	3A	Standard display	Ex nA nC IIB+H ₂ T4 Gc
		No display or IIC display	Ex nA nC IIC T4 Gc
		Dust marking	Ex tc IIIC T75 °C Dc IP66/IP67
Non sparking with a remote transmitter on the sensor	3A	Standard display	Ex nA nC [ib Gb] IIB+H ₂ T4 Gc
		No display or IIC display	Ex nA nC [ibGb] IIC T4 Gc
		Dust marking	Ex tc [ib Db] IIIC T75 °C Dc IP66/IP67

FOUNDATION Fieldbus — ordering code N

Classification	Approval code	Approval	
Flameproof	IA	Standard display	Ex db [ib] IIB+H ₂ T6 Gb
		No display or IIC display	Ex db [ib] IIC T6 Gb
		Dust marking	Ex tb [ib] IIIC T75 °C Db IP66/IP67
Flameproof/Increased safety	EA	Standard display	Ex db eb [ib] IIB+ H ₂ T6 Gb
		No display or IIC display	Ex db eb [ib] IICT6 Gb
		Dust marking	Ex tb [ib] IIIC T75 °C Db IP66/IP67
Non sparking with an integral transmitter on the sensor	3A	Standard display	Ex nA IIB+H ₂ T4 Gc
		No display or IIC display	Ex nA IIC T4 Gc
		Dust marking	Ex tc IIIC T75 °C Dc IP66/IP67
Non sparking with a remote transmitter on the sensor	3A	Standard display	Ex nA [ib Gb] IIB + H ₂ T4 Gc
		No display or IIC display	Ex nA [ib Gb] IIC T4 Gc
		Dust marking	Ex tc [ib Db] IIIC T75 °C Dc IP66/IP67

FOUNDATION Fieldbus FISCO or PROFIBUS-PA — ordering code E

FISCO covers Ex ia, ib, and ic.

Classification	Approval code	Approval	
Flameproof	IA	Standard display	Ex db [ia Ga] [ib] IIB+H ₂ T6 Gb
		No display or IIC display	Ex db [ia Ga][ib] IIC T6 Gb
		Dust marking	Ex tb [ia Da] [ib] IIIC T75 °C Db IP66/IP67
Flameproof/Increased safety	EA	Standard display	Ex db eb [ia Ga][ib] IIB+H ₂ T6 Gb
		No display or IIC display	Ex db eb [ia Ga] [ib] IIC T6 Gb
		Dust marking	Ex tb [ia Da] [ib] IIIC T75 °C Db IP66/IP67
Non sparking with an integral transmitter on the sensor	3A	Standard display	Ex nA [ic] IIB+H ₂ T4 Gc
		No display or IIC display	Ex nA [ic] IIC T4 Gc
		Dust marking	Ex tc IIIC T75 °C Dc IP66/IP67
Non sparking with a remote transmitter on the sensor	3A	Standard display	Ex nA [ic] [ib Gb] IIB+H ₂ T4 Gc
		No display or IIC display	Ex nA [ic] [ib Gb] IIC T4 Gc
		Dust marking	Ex tc [ib Db] IIIC T75 °C Dc IP66/IP67

Intrinsically safe outputs — ordering code D**Note**

For EA and 3A approval codes, the marking will change when installed with Smart Wireless 775 THUM.

Classification	Approval code	Approval	
Flameproof	IA	Standard display	Ex db [ib] [ia] IIB+H ₂ T6 Gb
		No display or IIC display	Ex db [ib] [ia] IIC T6 Gb
		Dust marking	Ex tb [ib] [ia] IIIC T75 °C Db IP66/IP67
Flameproof/Increased safety	EA	Standard display	Ex db eb [ib] [ia] IIB+ H ₂ T6 Gb
		No display or IIC display	Ex db eb [ib] [ia] IIC T6 Gb
		Dust marking	Ex tb [ib] [ia] IIIC T75 °C Db IP66/IP67

IECEx mounting options for all models

Code	Description
IA (all mounting options)	Used in IECEx EPL Gb/Db Zone 1/21 with flameproof (Ex db) terminal compartment with [ib] output for sensors installed in Zone 1/21
EA (all mounting options except stainless steel option)	Used in IECEx EPL Gb/Db Zone 1/21 with increased safety (Ex eb) terminal compartment and flame proof (Ex db) electronic compartment with [ib] output for sensors installed in Zone 1/21
3A (mounting option I) ⁽¹⁾	Used in IECEx EPL Gc/Dc Zone 2/22, non sparking
3A (mounting option R and C) ⁽¹⁾	Used in IECEx EPL Gc/Dc Zone 2/22, non sparking with [ib Gb/Db] output for sensors installed in Zone 1/21

⁽¹⁾ Not available for a 5700 configuration with intrinsically safe outputs

ATEX

Ambient temperature range is -40 °F (-40.0 °C) to 149 °F (65.0 °C) for ATEX compliance.

Configurable I/O — ordering code A



Note

For ZA and VA approval codes, the marking will change when installed with Smart Wireless 775 THUM.





Classification	Approval code	Approval
Flameproof	FA	Standard or Wi-Fi IIB display CE ²⁴⁰⁰ Ex II 2 G/D Ex db [ib] IIB+H ₂ T6 Gb
		No display, standard IIC, or Wi-Fi IIC display Ex db [ib] IIC T6 Gb
		Dust marking Ex tb [ib] IIIC T75 °C Db IP66/IP67
Flameproof/Increased safety	ZA	Standard or Wi-Fi IIB display CE ²⁴⁰⁰ Ex II 2 G/D Ex db eb [ib] IIB+H ₂ T6 Gb
		No display, standard IIC, or Wi-Fi IIC display Ex db eb [ib] IIC T6 Gb
		Dust marking Ex tb [ib] IIIC T75 °C Db IP66/IP67
Non sparking with an integral transmitter on the sensor	VA	Standard or Wi-Fi IIB display CE ^{Ex} II 3 G/D Ex nA nC IIB+H ₂ T4 Gc
		No display, standard IIC, or Wi-Fi IIC display Ex nA nC IIC T4 Gc
		Dust marking Ex tc IIIC T75 °C Dc IP66/IP67
Non sparking with a remote transmitter on the sensor	VA	Standard or Wi-Fi IIB display CE ^{Ex} II 3(2) G/D Ex nA nC [ib Gb] IIB+H ₂ T4 Gc
		No display, standard IIC, or Wi-Fi IIC display Ex nA nC [ib Gb] IIC T4 Gc
		Dust marking Ex tc [ib Db] IIIC T75 °C Dc IP66/IP67

Ethernet — ordering code C

Classification	Approval code	Approval
Flameproof	FA	Standard display CE ²⁴⁰⁰ Ex II 2 G/D Ex db [ib] IIB+H ₂ T6 Gb
		No display or IIC display Ex db [ib] IIC T6 Gb
		Dust marking Ex tb [ib] IIIC T75 °C Db IP66/IP67

Classification	Approval code	Approval	
Non sparking with an integral transmitter on the sensor	VA	Standard display	CE  Ex nA nC IIB+H ₂ T4 Gc
		No display or IIC display	Ex nA nC IIC T4 Gc
		Dust marking	Ex tc IIIC T75 °C Dc IP66/IP67
Non sparking with a remote transmitter on the sensor	VA	Standard display	CE  Ex nA nC [ib Gb] IIB+H ₂ T4 Gc
		No display or IIC display	Ex nA nC [ib Gb] IIC T4 Gc
		Dust marking	Ex tc [ib Db] IIIC T75 °C Dc IP66/IP67

FOUNDATION Fieldbus — ordering code N

Classification	Approval code	Approval	
Flameproof	FA	Standard display	CE ²⁴⁶⁰  II 2G/D Ex db [ib] IIB+H ₂ T6 Gb
		No display or IIC display	Ex db [ib] IIC T6 Gb
		Dust marking	Ex tb [ib] IIIC T75 °C Db IP66/IP67
Flameproof/Increased safety	ZA	Standard display	CE ²⁴⁶⁰  II 2 G/D Ex db eb [ib] IIB+H ₂ T6 Gb
		No display or IIC display	Ex db eb [ib] IIC T6 Gb
		Dust marking	Ex tb [ib] IIIC T75 °C Db IP66/IP67
Non sparking with an integral transmitter on the sensor	VA	Standard display	CE  Ex nA IIB+H ₂ T4 Gc
		No display or IIC display	Ex nA IIC T4 Gc
		Dust marking	Ex tc IIIC T75 °C Dc IP66/IP67
Non sparking with a remote transmitter on the sensor	VA	Standard display	CE  Ex nA [ib Gb] IIB+H ₂ T4 Gc
		No display or IIC display	Ex nA [ib Gb] IIC T4 Gc
		Dust marking	Ex tc [ib Db] IIIC T75 °C Dc IP66/ IP67

FOUNDATION Fieldbus FISCO or PROFIBUS-PA — ordering code E

FISCO covers Ex ia, ib, and ic.

Classification	Approval code	Approval	
Flameproof	FA	Standard display	CE ²⁴⁰⁰ Ex II (1) 2 G/D Ex db [ia Ga] [ib] IIB+H ₂ T6 Gb
		No display or IIC display	Ex db [ia Ga] [ib] IIC T6 Gb
		Dust marking	Ex tb [ia Da] [ib] IIIC T75 °C Db IP66/IP67
Flameproof/Increased safety	ZA	Standard display	CE ²⁴⁰⁰ Ex II (1) 2 G/D Ex db eb [ia Ga] [ib] IIB+H ₂ T6 Gb
		No display or IIC display	Ex db eb [ia Ga] [ib] IIC T6 Gb
		Dust marking	Ex tb [ia Da] [ib] IIIC T75 °C Db IP66/IP67
Non sparking with an integral transmitter on the sensor	VA	Standard display	CE ^{Ex} Ex nA [ic] IIB+H ₂ T4 Gc
		No display or IIC display	Ex nA [ic] IIC T4 Gc
		Dust marking	Ex tc IIIC T75 °C Dc IP66/IP67
Non sparking with a remote transmitter on the sensor	VA	Standard display	CE ^{Ex} Ex nA [ic] [ib Gb] IIB+H ₂ T4 Gc
		No display or IIC display	Ex nA [ic] [ib Gb] IIC T4 Gc
		Dust marking	Ex tc [ib Db] IIIC T75 °C Dc IP66/ IP67

Intrinsically safe outputs — ordering code D

Note

For ZA approval codes, the marking will change when installed with Smart Wireless 775 THUM.

Classification	Approval code	Approval	
Flameproof	FA	Standard display	CE ²⁴⁰⁰ Ex II 2 G/D Ex db [ib] [ia] IIB+H ₂ T6 Gb
		No display or IIC display	Ex db [ib] [ia] IIC T6 Gb
		Dust marking	Ex tb [ib] [ia] IIIC T75 °C Db IP66/ IP67
Flameproof/Increased safety	ZA	Standard display	CE ²⁴⁰⁰ Ex II 2 G/D Ex db eb [ib] [ia] IIB+H ₂ T6 Gb
		No display or IIC display	Ex db eb [ib] [ia] IIC T6 Gb
		Dust marking	Ex tb [ib] [ia] IIIC T75 °C Db IP66/ IP67

ATEX mounting codes for all models

Code	Description
FA (all mounting options)	Used in ATEX II 2 G/D Zone 1/21 with flameproof (Ex db) terminal compartment with [ib] output for sensors installed in Zone 1/21.
ZA (all mounting options except stainless steel option)	Used in ATEX II 2 G/D Zone 1/21 with increased safety (Ex eb) terminal compartment and flame proof (Ex db) electronic compartment with [ib] output for sensors installed in Zone 1/21
VA (mounting option I) ⁽¹⁾	Used in ATEX II 3 G/D Zone 2/22 with non-sparking.
VA (mounting option R and C) ⁽¹⁾	Used in ATEX II (2) 3 G/D Zone 2/22, non-sparking with [ib Gb/Db]output for sensors installed in Zone 1/21.

(1) Not available for a 5700 configuration with intrinsically safe outputs.

Environmental compliance

	<p>The battery in the 5700 transmitter cannot be serviced or replaced by users. In compliance with RoHS (Restriction of Hazardous Substances) and WEEE (Waste Electrical and Electronic Equipment), Micro Motion provides a service for battery replacement and disposal.</p> <p>The 5700 transmitter complies with RoHS Directive 2011/65/EU.</p>
Ingress protection	<p>5700 transmitters contain the following ingress protection for specific transmitters:</p> <ul style="list-style-type: none"> ■ All 5700 transmitters have NEMA 4X protection. ■ 5700I transmitters have IP66/IP67 protection. ■ 5700 remote mount transmitters have IP66/IP67/IP69(K)⁽¹⁾ protection.

(1) The protection is IP69K when using standard NEN-ISO 20653:2013 and IP69 when using standard IEC/EN 60529.

Physical specifications

For transmitters integrally mounted to a sensor, you may need to add the weight of the transmitter to the sensor. Refer to the Sensor Product Data Sheet.

Materials of construction

Where 4-wire cable is required, use Micro Motion 4-wire cable, depending on the specific model number ordered, 10 ft (3 m) of shielded PVC cable (4-wire or 9-wire) will be included (see ordering information for details). For longer cable lengths, contact Customer Support.

Specification	Value
Housing	<ul style="list-style-type: none"> ■ Polyurethane-painted cast aluminum ■ 316 stainless steel
Weight	<ul style="list-style-type: none"> ■ Painted aluminum, 4-wire and 9-wire remote: 16 lb (7.3 kg) ■ Painted aluminum integral: 11 lb (5 kg) ■ Stainless steel remote version without bracket: 34 lb (15.4 kg) ■ Stainless steel remote version with bracket: 41 lb (18.6 kg)
Terminal compartments	<ul style="list-style-type: none"> ■ Output terminals are physically separated from the power and service-port terminals
Cable gland entrances	<ul style="list-style-type: none"> ■ 4-wire remote: M20 x 1.5 female or 1/2 in - 14 NPT conduit entries are available ■ 9-wire remote: 3/4 in - 14 NPT female conduit port for sensor cable. For power and I/O, M20 x 1.5 female, or 1/2 in - 14 NPT conduit entries are available.
Optional M12 connections (Ethernet version only)	<ul style="list-style-type: none"> ■ Pre-installed M12 quick connections available as an option ■ Option of (2) pre-installed for Ethernet connections and an option for additional (2) connections for power and configurable output ■ Suitable for Class 1, Division 2 approval only
Mounting	<ul style="list-style-type: none"> ■ Integral or remote mounting options (stainless steel is available only for remote installations) ■ May be remotely connected to any 4-wire or 9-wire Micro Motion sensor ■ Remote mount aluminum housing version includes a 304L stainless steel mounting bracket and hardware for installing the transmitter on the mounting bracket ■ Remote mount stainless steel housing version includes a 316L stainless steel mounting bracket and hardware for installing the transmitter on the mounting bracket ■ For remote 4-wire or 9-wire mounts, the transmitter can be rotated 360 degrees with respect to customer wall or pipe in 90-degree increments ■ For integral mount, the transmitter can be rotated with respect to the sensor in 45-degree increments

Specification	Value		
Maximum cable lengths between sensor and transmitter ⁽¹⁾	Cable type	Wire gauge	Maximum length
	Micro Motion 9-wire	Not applicable	1,000 ft (305 m) ⁽²⁾
	Micro Motion 4-wire	Not applicable	1,000 ft (305 m)
	User-supplied 4-wire	VDC 22 AWG (0.326 mm ²)	300 ft (91 m)
		VDC 20 AWG (0.518 mm ²)	500 ft (152 m)
VDC 18 AWG (0.823 mm ²)		1,000 ft (305 m)	
	RS-485 22 AWG (0.326 mm ²) or larger	1,000 ft (305 m)	
Standard interface/display	<ul style="list-style-type: none"> ■ Graphical backlit display with 4-button optical controls and flow meter-status LED ■ Depending on purchase option, transmitter housing cover has either a non-glass lens or tempered glass lens option ■ To facilitate various mounting orientations, the display can be rotated on transmitter, 360 degrees, in 90-degree increments ■ Display supports English, German, French, Spanish, Portuguese, Russian, Chinese, and Japanese 		
Display functions	<ul style="list-style-type: none"> ■ Complete operation and configuration through the display, no service tool required ■ View process variables ■ Start, stop, and reset totalizers ■ View and acknowledge alarms ■ View the Smart Meter Verification initiation and results from the display without interrupting process measurement ■ Set the flow meter to zero, simulate outputs, change measurement units, configure outputs, and set RS-485 communications options ■ View a three-color LED status light on display panel that indicates flow meter conditions at a glance 		
Wi-Fi display option (5700 with configurable inputs and outputs only)	<ul style="list-style-type: none"> ■ Wi-Fi display option enables point-to-point wireless communication in order to configure and characterize the meter, download historical files, and run Smart Meter Verification for troubleshooting purposes. ■ Wireless communication is available for PCs with ProLink III version 4.6 or greater. ProLink III is available for iOS/Android tablets for use with the Wi-Fi display option. ■ The maximum Wi-Fi connection distance is 115 ft (35 m) from the front display and 50 ft (15 m) from the sides and back of the transmitter housing. 		

(1) For the cable sizing formula, see the appropriate Micro Motion 5700 installation manual.

(2) For Smart Meter Verification, the limit is 60 ft (18 m).

Dimensions

Remote mount aluminum transmitter

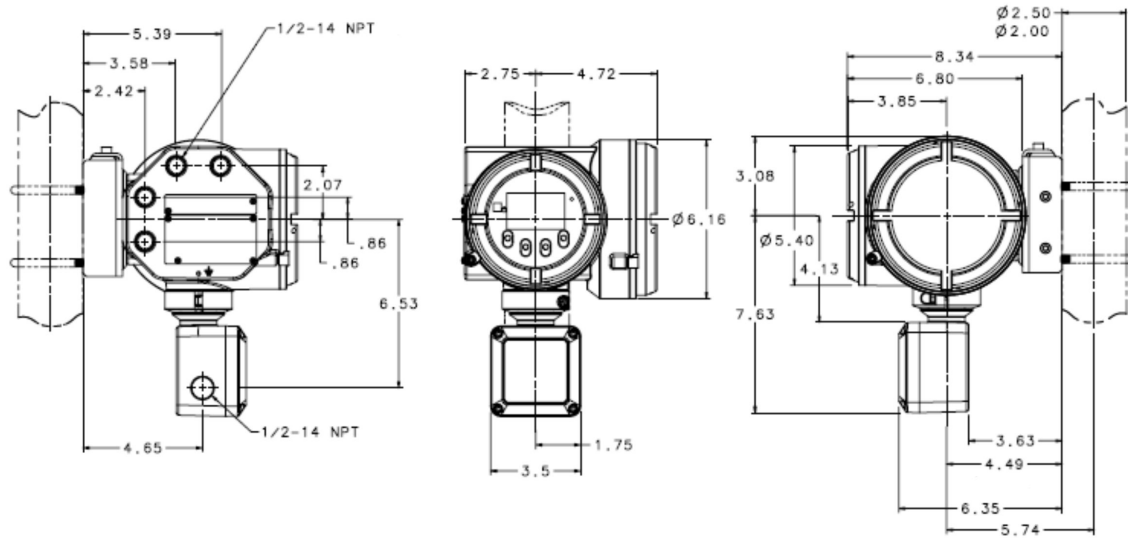

Remote mount stainless steel transmitter

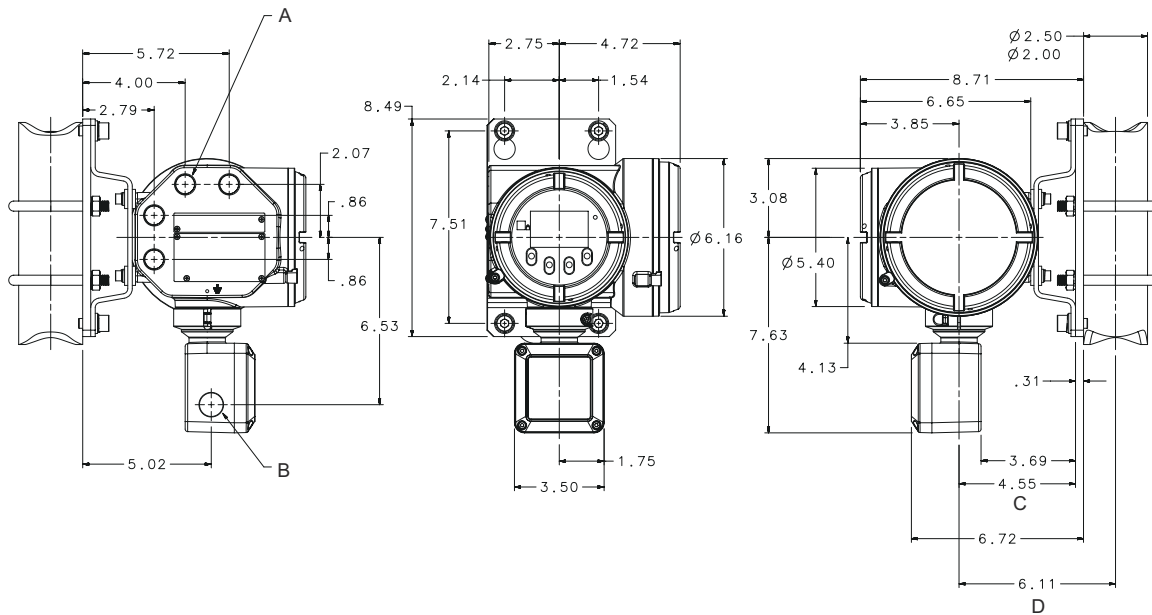

- A. 4 x 1/2 in - 14 NPT or M20 x 1.5 female
- B. 3/4 in - 14 NPT female
- C. Wall mount
- D. Pole mount

Integral mount aluminum transmitter

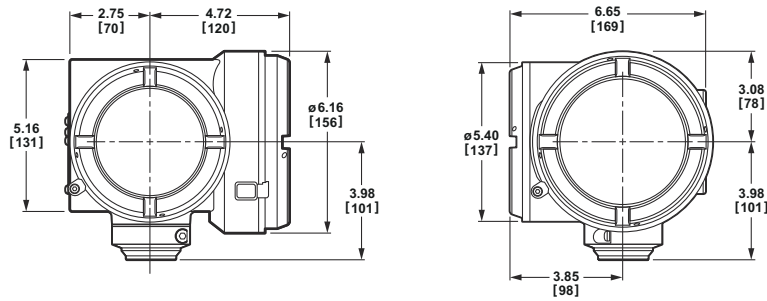

Ordering information

Model

Model	Product description
5700	Micro Motion Coriolis field mount transmitter

Mounting options

Code	Description
I	Integral mount transmitter (polyurethane-painted aluminum housing)
R	4-wire remote mount transmitter (polyurethane-painted aluminum housing), bracket for wall or pipe mounting, and hardware for 2 in (51 mm) pipe mount, includes 10 ft (3 m) 4-wire shielded PVC cable
C	9-wire remote transmitter with integrated core processor (polyurethane-painted aluminum housing), bracket for wall or pipe mounting, and hardware for 2 in (51 mm) pipe mount, includes 10 ft (3 m) 9-wire CFEPS cable
M ⁽¹⁾	4-wire remote mount transmitter (stainless steel housing), bracket for wall or pipe mounting and hardware for 2 in (51 mm) pipe mount
P ⁽¹⁾	9-wire remote mount transmitter with integrated core processor (stainless steel housing), bracket for wall or pipe mounting, and hardware for 2 in (51 mm) pipe includes 10 ft (3 m) CFEPS cable

(1) Not available with approval codes ZA, EA, KA, or R1

Power options

Code	Description
1	18 to 100 VDC or 85 to 240 VAC; self switching

Display options

Available with all approval codes

Code	Description
2	Backlit graphic display for CSA, UL, and IIB + H2 ATEX, and IECEx ratings
3	No display
U ⁽¹⁾	Backlit graphic display for CSA, UL, and IIB + H2 ATEX and IECEx ratings with Wi-Fi

(1) Available with configurable I/O version only.

Available with FA, ZA, IA, EA, R1 and R2 approval codes

Code	Description
5	Backlit graphic display for IIC ATEX, IECEx, and NEPSI rating
V ⁽¹⁾	Backlit graphic display for IIC ATEX, IECEx, and NEPSI rating with Wi-Fi

(1) Available with configurable I/O version only.

Available with MA approval code

Code	Description
7	Non-glass backlit graphic display
W ⁽¹⁾	Non-glass backlit graphic display with Wi-Fi

(1) Available with configurable I/O version only.

Output board options

Code	Description
A	Configurable outputs
C ⁽¹⁾⁽²⁾	Ethernet outputs, select EtherNet/IP, Modbus TCP, or PROFINET in channel assignment section
E ⁽¹⁾	Intrinsically safe FOUNDATION Fieldbus H1 or PROFIBUS-PA outputs – select FOUNDATION Fieldbus or PROFIBUS-PA in Output channel assignments .
N ⁽¹⁾	Non-intrinsically safe FOUNDATION Fieldbus H1 outputs
D ⁽³⁾	Intrinsically safe outputs

(1) Not available with Certificate Option SI.

(2) Not available with approval options ZA, EA, or R1.

(3) Not available with approval options VA, 3A, or R3.

Conduit connection options

Code	Description
B	1/2 in NPT — no gland
C ⁽¹⁾	1/2 in NPT with brass/nickel cable gland
D ⁽¹⁾	1/2 in NPT with stainless steel cable gland

Code	Description
E	M20 — no gland
F ⁽¹⁾	M20 with brass/nickel cable gland
G ⁽¹⁾	M20 with stainless steel cable gland

(1) Not approved in Class 1 Division 1 installations.

Approval options

Code	Description
MA	Micro Motion Standard (no approval)
AA	CSA (US and Canada): Class I, Division 1, Groups C and D
ZA	ATEX: II 2G, Ex db eb, Zone 1 and II 2D Ex tb, Zone 21
FA	ATEX: II 2G, Ex d, Zone 1 and II 2D Ex tb, Zone 21
IA	IECEX: EPL Gb, Ex d, Zone 1 and EPL Db Ex tb, Zone 21
EA	IECEX: EPL Gb, Ex db eb, Zone 1 and EPL Db Ex tb, Zone 21
2A	CSA (US and Canada): Class I, Division 2, Groups A, B, C, D; sensor connections will be intrinsically safe without additional barrier
VA ⁽¹⁾⁽²⁾	ATEX: II 3G, Ex nA nC, Zone 2 and II 3D Ex tc Zone 22
3A ⁽¹⁾	IECEX: EPL Gc, Ex nA nC, Zone 2 and EPL Dc, Ex tc, Zone 22
R1	EAC: Ex de, Zone 1
R2	EAC: Ex d, Zone 1
R3	EAC: nA nC, Zone 2

(1) Sensor connections will be intrinsically safe without additional barrier.

(2) The 5700 stainless steel transmitter is flameproof (Exd) only. Applicable for approval codes ZA, EA, and R1.

Transmitter option 1

Code	Description
Z	Standard product

Transmitter option 2

Code	Description
Z	Standard product

Factory options

Code	Description
Z	Standard product
X	ETO product

Output channel assignments

Channel A

Channel A: Available with output board code A

Code	Description
Z	Channel Off
A	Channel On; mA Output with HART

Channel A: Available with output board code C

Code	Description
C	EtherNet/IP output 1
D	Modbus TCP output 1
H	PROFINET output 1

Channel A: Available with output board code E

Code	Description
F ⁽¹⁾	Intrinsically safe FOUNDATION Fieldbus H1 outputs (fixed)
G ⁽²⁾⁽³⁾	PROFIBUS-PA output (fixed)

(1) Not available with additional feature codes NT, OG, OL, MW, BS, SI, MA, PWL.

(2) Only available with approval codes MA, AA, ZA, FA, IA, EA, 2A, VA, 3A.

(3) Not available with additional feature codes NT, OG, OL, MW, BS, SI.

Channel A: Available with output board code N

Code	Description
F ⁽¹⁾	Non-intrinsically safe FOUNDATION Fieldbus H1 outputs

(1) Not available with additional feature codes NT, OG, OL, MW, BS, SI, MA, PWL.

Channel A: Available with output board code D

Code	Description
Z	Channel Off
B	Channel On; Intrinsically safe mA Output with HART™

Channel B

Channel B: Available with output board code A

Code	Description
Z	Channel Off
A	Channel On; Configurable to mA Output, Frequency Output, and Discrete Output

Channel B: Available with output board code C

Your selection must match Channel A.

Code	Description
C	EtherNet/IP output 1
D	Modbus TCP output 1
H	PROFINET output 1

Channel B: Available with output board codes E and N

Code	Description
E	Channel On; mA Output

Channel B: Available with output board code D

Code	Description
Z	Channel Off
B	Channel On; Intrinsically safe mA Output

Channel C

Channel C: Available with output board code A

Code	Description
Z	Channel Off
A	Channel On; Configurable to mA Output, Frequency Output, Discrete Output, and Discrete Input

Channel C: Available with output board code C

Code	Description
C	Configurable to mA Output, Frequency Output, Discrete Output, and Discrete Input

Channel C: Available with output board codes E and N

Code	Description
E	Channel On; Configurable to Frequency Output, and Discrete Output

Channel C: Available with output board code D

Code	Description
Z	Channel Off
B	Channel On; Intrinsically safe mA Output

Channel D**Channel D: Available with output board code A**

Code	Description
Z	Channel Off
A	Channel On; Configurable to mA Input, Frequency Input, Frequency Output, Discrete Output, and Discrete Input

Channel D: Available with output board code C

Code	Description
Z	Channel Off

Channel D: Available with output board codes E and N

Code	Description
Z	Channel Off

Channel D: Available with output hardware board code D

Code	Description
Z	Channel Off
B	Channel On; Intrinsically safe, configurable to mA Output, Frequency Output, Discrete Output

Channel E**Channel E: Available with output board code A**

Code	Description
Z	Channel Off
A	On; RS-485 Modbus, RS-485 HART™, and printing support

Channel E: Available with output board codes C, E, N, and D

Code	Description
Z	Channel Off

Additional features

All of the following additional features are optional.

Instrument Tagging

Code	Description
TG	Instrument Tagging — customer information required (maximum 24 characters)

Smart Meter Verification

Code	Description
MV ⁽¹⁾	Smart Meter Verification

(1) Available with all mounting options, but mounting C is limited to 60 ft (18.29 m) of 9-wire cable and only available when purchased with new 9-wire sensor.

Weights & Measures approval

Requires output board code A (or C for option NT only) and display code 2, 5, or 7. Select only one of the following codes.

Code	Description
NT ⁽¹⁾	Weights & Measures custody transfer approval — NTEP
OG ⁽¹⁾	Weights & Measures custody transfer approval — MID && OIML for gas
OL ⁽¹⁾	Weights & Measures custody transfer approval — MID && OIML for liquid

(1) Not available with PL, PG, PO, MA, MW, or SI.

Enhanced measurement

Select only one of the following codes.

Code	Description
PS ⁽¹⁾	API referral software
CM ⁽¹⁾	Concentration measurement software
PW ⁽¹⁾⁽²⁾⁽³⁾	Piecewise Linearization for Gas software

(1) Not available with PL, PG, PO, MA, MW, or SI.

(2) Not available with hardware board E with Channel A, output option F, or hardware boards N or D.

(3) Not available with add on option PL.

Additional software options

Code	Description
BS ⁽¹⁾	Batching software package

(1) Not available with output hardware board E with Channel A output option, or hardware board N. Not available with certification option SI.

Advanced Phase Measurement

Select any of the following feature codes.

Code	Description
PG ⁽¹⁾⁽²⁾⁽³⁾	Advanced Phase Measurement gas with liquid
PL ⁽¹⁾⁽²⁾	Advanced Phase Measurement liquid with gas

(1) Not available with add on options NT, OL, OG, or SI.

(2) Not available with add on option PS.

(3) Not available with add on option CM.

Net Oil Computer software

Select only one of the following codes.

Code	Description
MA ⁽¹⁾⁽²⁾	Manual Advanced Phase Measurement configuration
MW ⁽²⁾⁽³⁾	Net Oil Computer software — multiple wells
PO ⁽⁴⁾	Net Oil Computer software — single well Micro Motion highly recommends the PL option in conjunction with PO.
Additional certification requires either:	
<ul style="list-style-type: none"> ■ Hardware output board option A with output Channel A and Channel D assignment of "A" ■ Hardware output board option D with output Channel A assignment of "B" 	
SI	Safety certification of 4-20 mA Outputs per IEC 61508

(1) Not available with hardware board E with Channel A output option F, or hardware boards N or D.

(2) Not available with add on options NT, OG, OL, PL, PS, or SI.

(3) Available only with output hardware board option A.

(4) Not available with add on options CM, NT, OG, OL, PS, or SI.

Smart Wireless 775 THUM

Smart Wireless 775 THUM requires output code A or B option for Channel A.

Code	Description
NI	Smart Wireless 775 THUM Ready — 775 ordered separately and not assembled to the 5700

Ethernet connectors

Requires output hardware board code C. Select only one of the following codes.

Code	Description
CA ⁽¹⁾	(2) M12 connectors for Ethernet ports
CB ⁽¹⁾	(2) M12 connectors for Ethernet ports and (1) for Channel C and (1) for power

(1) Available only with approval codes MA and 2A.

Marine Bunkering Software

Code	Description
BK ⁽¹⁾⁽²⁾	Marine Bunkering Software

(1) Available only with configurable inputs and outputs version, output board option A.

(2) Not available with Add on Options PL, PG, PO, MA, MW, PW, PS, CM, BS, SI, W7, NT, or OG.

For more information: www.emerson.com

©2023 Micro Motion, Inc. All rights reserved.

The Emerson logo is a trademark and service mark of Emerson Electric Co. Micro Motion, ELITE, ProLink, MVD and MVD Direct Connect marks are marks of one of the Emerson Automation Solutions family of companies. All other marks are property of their respective owners.