

Rosemount™ 326L Level Transmitter

Guided Wave Radar



The Rosemount 326L Level Transmitter is designed to provide accurate and repeatable continuous level measurements in the food and beverage industry.

Emerson is here to optimize your food and beverage operations

The Rosemount 326L Level Transmitter ensures your process level is always in specification

- Measuring Range: up to 78.7 in. (2000 m)
- Process Temperature: Up to 302°F (150°C)
- Wetted Materials: 316L SST Polished to Ra < 32 μ-in. (0.8 μ-m), EPDM, PEEK
- Ingress Protection: IP69K
- Communication protocol: 4-20 mA, IO-Link, Switch



Emerson offers a broad portfolio of products to solve your toughest challenges

From simple measurements to critical applications, Emerson’s extensive portfolio of solutions has you covered. Our reliable, easy-to-use, and innovative products will help you to maximize production, maintain quality control and product consistency, minimize product losses, and assure the safety of your products.

Emerson offers a full service organization to give you the support you need



From simple repairs to complex projects, Emerson supports you with training and instrument services that improve the maintenance, reliability and performance of your products and, ultimately, your process equipment and production quality. We have a full organization of experienced and certified personnel. With both factory and regional service centers, we offer unmatched local support.

Contents

Emerson is here to optimize your food and beverage operations.....	2
Ordering information.....	3
Accessories.....	3
Specifications.....	5
Product certifications.....	9
Dimensional drawings.....	10

Ordering information

Table 1: 326L Level Transmitter ordering information

The Standard offering represents the most common options. The starred options (★) should be selected for best delivery. The Expanded offering is subject to additional delivery lead time.

Model		
326L	Level transmitter	★
Process connection type		
G10	G1" Thread	★
Housing material		
A	Stainless Steel	★

Optional options (include with the selected model number)

Material traceability certificate		
Q8	Material Traceability per EN 10204 3.1B	

Note

Optional options will not be included in the model string printed on the transmitter. For product reorder, make sure to include any desired optional options in the model string.

Accessories

These accessories are available for the Rosemount 326L Transmitter.

Hygienic process connection adaptaters

Type	Description	Part Number
1-1.5 in. Tri-clamp	316L SST, EPDM o-ring, 232 psi (16 bar) max pressure, 16 μ-in (0.4 μ-m) surface finish, 3-A, FDA	FB-1001
2.0 in. Tri-clamp	316L SST, EPDM o-ring, 232 psi (16 bar) max pressure, 16 μ-in (0.4 μ-m) surface finish, 3-A, FDA	FB-1002
Varivent Type F	316L SST, EPDM o-ring, 362 psi (25 bar) max pressure, 16 μ-in (0.4 μ-m) surface finish, 3-A, FDA	FB-1010
Varivent Type N	316L SST, EPDM o-ring, 362 psi (25 bar) max pressure, 16 μ-in (0.4 μ-m) surface finish, 3-A, FDA	FB-1011
DIN 11851 DN32	316L SST, EPDM o-ring, 580 psi (40 bar) max pressure, 16 μ-in (0.4 μ-m) surface finish, FDA	FB-1020
DIN 11851 DN40	316L SST, EPDM o-ring, 580 psi (40 bar) max pressure, 16 μ-in (0.4 μ-m) surface finish, FDA	FB-1021

Type	Description	Part Number
DIN 11851 DN50	316L SST, EPDM o-ring, 580 psi (40 bar) max pressure, 16 μ -in (0.4 μ -m) surface finish, FDA	FB-1022
D50 Weld-in Adapter	316L SST, EPDM o-ring, 725 psi (50 bar) max pressure, 16 μ -in (0.4 μ -m) surface finish, 3-A, FDA	FB-1041
Universal Adapter RD52	316L SST; EPDM o-ring; 232 psi (16 bar) max pressure; FDA	FB-1045
G1 Welding Mandrel	Absorbs heat and prevents warping during welding of FB-1041	FB-6041

Note

For a material traceability certificate, add option code Q8 after your part number (Ex: FB-1001Q8). Additional delivery lead times may apply. The certification option (Q8) will not be included in the part number printed on the transmitter. For product reorder, make sure to include any desired certification in the part number.

Probes

These probes are available for the Rosemount 326L Transmitter. All probes are polished to Ra < 32 μ -in. (0.8 μ -m).

Description	Part number
5.9 in. (150 mm)	FB-2015
11.8 in. (300 mm)	FB-2030
19.7 in. (500 mm)	FB-2050
27.6 in. (700 mm)	FB-2070
39.4 in. (1000 mm)	FB-2100
59.1 in. (1500 mm)	FB-2150
78.7 in. (2000 mm)	FB-2200

Note

For a material traceability certificate, add option code Q8 after your part number (Ex: FB-2015Q8). Additional delivery lead times may apply.

O-rings

Description	Part number
Hygienic Adapter O-ring; FKM, Qty 1	FB-3001
Hygienic Adapter O-ring; FKM; Qty 5	FB-3002
Hygienic Adapter O-ring; EPDM; Qty 5	FB-3003
Hygienic Adapter Upper Gasket; PEEK; Qty 1	FB-3010
Rosemount 326L Probe O-ring; EPDM; Qty 5	FB-3020
Rosemount 326L Probe O-ring; FKM; Qty 5	FB-3021

Cables and connectors

Description	Length	Part number
Hygienic Wireable Terminal Connector - M12 Female (angled) to Screw Terminals Operating voltage: <250 AC / <300 DC, Max current: 4A, Ambient temp: -13°F - 212°F (-25°C - 100°C), Screw Terminals: 23AWG - 17AWG 316L SST, gold plated contacts, EPDM sealing, IP69K	Wireable socket	FB-4000
	6.6 ft. (2 m)	FB-4002
Hygienic Cable - M12 Female (angled) to Flying Lead (4 x 22AWG) Operating voltage: <250 AC / <300 DC, Max current: 4A, Ambient temp: -13°F - 212°F (-25°C - 100°C), cULus approval limited to 149°F (65°C) 316L SST, gold plated contacts, EPDM sealing, IP69K	16.4 ft. (5 m)	FB-4005
	32.8 ft. (10 m)	FB-4010
	65.6 ft. (20 m)	FB-4020
	164 ft. (50 m)	FB-4050
	1.97 ft. (0.6 m)	FB-4106
Hygienic Patch Cable - M12 Female (angled) to M12 Male Operating voltage: <250 AC / <300 DC, Max current: 4A, Ambient temp: -13°F - 212°F (-25°C - 100°C), cULus approval limited to 149°F (65°C) 316L SST, gold plated contacts, EPDM sealing, IP69K	3.3 ft. (1 m)	FB-4101
	6.6 ft. (2 m)	FB-4102
	16.4 ft. (5 m)	FB-4105
	32.8 ft. (10 m)	FB-4110

Specifications

Performance specifications

Reference accuracy

± 0.27 in. (7 mm)

Maximum offset error

0.20 in. (5 mm)

Ambient temperature effect

± 0.2% measured distance per 18°F (10°C)

Electromagnetic compatibility

The Rosemount 326L meets the requirements of:

DIN EN 61000-6-2

DIN EN 61000-6-3 (in a metal tank)

DIN EN 61000-6-4 (in a plastic tank)

Vibration

The Rosemount 326L is tested to DIN EN 60068-2-6 with a reference rod of 19.7 in. (500 mm).

Peak acceleration of 20 g in the frequency range 10 to 2000 Hz.

Peak acceleration of 1 g in the frequency range 5 to 200 Hz.

Functional specifications

Service

Water and water-based media

Dielectric constant of media

> 5

Measuring range

Probe length

5.9 to 78.7 in. (150 to 2000 mm)

Active Range

L - 1.57 in. (L - 40 mm)

Blind zone

I1: 1.18 in. (30 mm)

I2: 0.39 in. (10 mm)

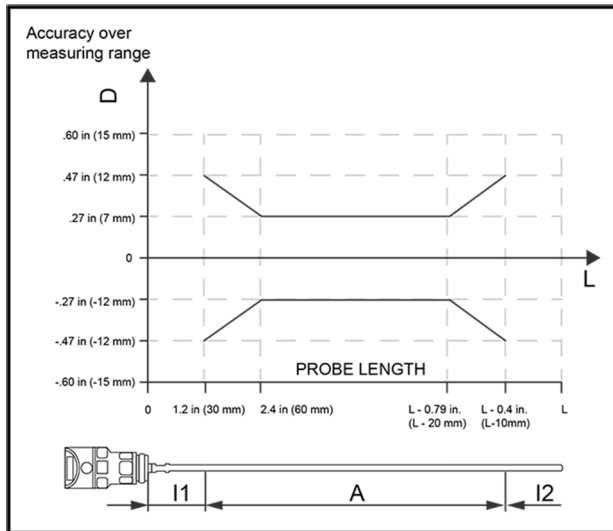

Sampling rate

4 Hz

Temperature limits

Process

-40 to 302 °F (-40 to 150 °C); -40 to 250 °F (-40 to 121 °C) for 3-A applications

Ambient

-40 to 176 °F (-40 to 80 °C)

Storage

-40 to 212 °F (-40 to 100 °C)

Pressure limits

-14.5 to 580 psi (-1 to 40 bar)

Power supply

18 – 30 V DC

Current draw

<50 mA

Protection class

III

Outputs

The Rosemount 326L can provide up to two outputs.

OUT1: Switching output (PNP/NPN) or IO-Link (digital)

OUT2: Switching output (PNP/NPN) or 4-20 mA (analog)

For more information on how to access these outputs see [Electrical connection](#).

Switch output

Max voltage drop: 2.5V

Permanent DC current rating: 150 mA; 200 mA if temperature is limited to 140°F (60°C)

IO-Link

Table 2:

IO-Link Device Parameters	
Transfer type	COM2 (38.4 kBaud)
IO-Link revision	1.1
SDCI standard	IEC 61131-9
SIO mode	Yes
Required master port class	A
Process data analog	1
Process data binary	2
Minimum process cycle time	2.3 ms

Indication / Local Operator Interface

The Rosemount 326L comes standard with a four-digit alphanumeric display as well as a Local Operator Interface (LOI). The three-button LOI provides the capability for local commissioning without extra tools/software. The display also includes LED indicators to identify transmitter display units and switch status. Display units available are inch, mm, and percentage (%).

Turn on time

Three seconds

Physical specifications

Material selection

Emerson provides a variety of Rosemount™ products with various product options and configurations including materials of construction that can be expected to perform well in a wide range of applications. The Rosemount product information presented is intended as a guide for the purchaser to make an appropriate selection for the application. It is the purchaser's sole responsibility to make a careful analysis of all process parameters (such as all chemical components, temperature, pressure, flow rate, abrasives, contaminants, etc.), when specifying product, materials, options and components for the particular application. Emerson is not in a position to evaluate or guarantee the compatibility of the process fluid or other process parameters with the product, options, configuration or materials of construction selected.

Process connections

External threaded G1 connection.

Process-wetted parts

Surface finish: Ra < 32 μ-in. (0.8 μ-m)

- 316L SST (1.4435)
- PEEK
- EPDM

Non-wetted parts

- 316L SST
- FKM
- PBT
- PEI
- PFA

Electrical connection

The Rosemount 326L is equipped with an M12 Female electrical connector which features gold-plated contacts.

The wiring configuration sets the transmitter output. The wiring diagram is shown in the following figure. For more information on wiring the transmitter, see the Rosemount 326L Quick Start Guide (00825-0100-4326).

Figure 1: Rosemount 326L Wiring Diagram

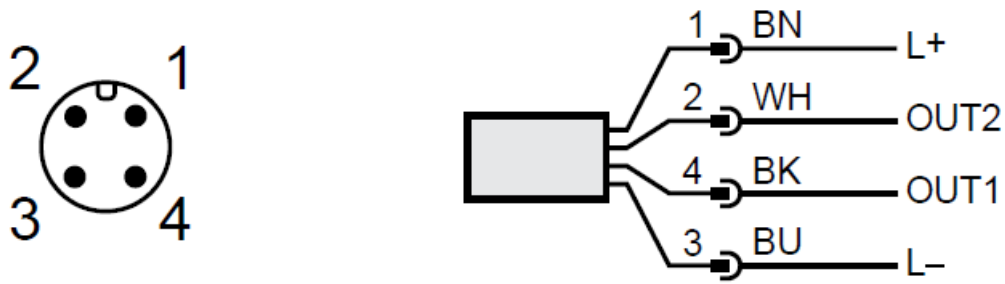

OUT1: Switching output (PNP/NPN) or IO-Link (digital)

OUT2: Switching output (PNP/NPN) or 4-20 mA (analog)

Shipping weight

0.89 lbs. (401.5 g)

Product certifications

European Directive Information

A copy of the EU Declaration of Conformity can be found at the end of the Quick Start Guide. The most recent revision of the EU Declaration of Conformity can be found at Emerson.com/Rosemount.

Ordinary Location Certification

As standard, the transmitter has been examined and tested to determine that the design meets the basic electrical, mechanical, and fire protection requirements by a nationally recognized test laboratory (NRTL) as accredited by the Federal Occupational Safety and Health Administration (OSHA).

3A[®] certification

This product is authorized to display the 3-A symbol. Ensure gaskets and process connection accessories selected for installation meet both the application and 3-A requirements. A certificate of compliance is available at Emerson.com/Rosemount.

Note

The 326L Level Transmitter should utilize clean-out-of-place (COP) procedures for 3-A applications.

Other industry certifications

All Rosemount 326L transmitter surfaces and materials which come into contact with process medium comply with the following regulations:

- (EC) No. 1935/2004
- (EC) No. 2023/2006
- CFR Title 21 (FDA) § 177.2600
- CFR Title 21 (FDA) § 177.2415

Dimensional drawings

Figure 2: Rosemount 326L Level Transmitter dimensional drawing

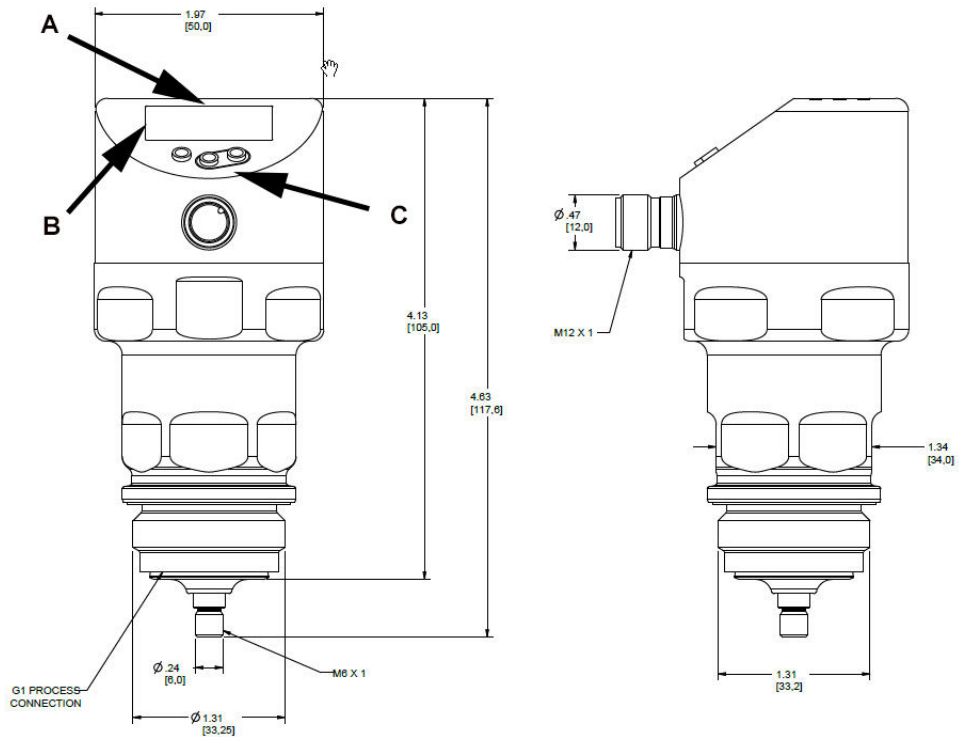

- A. Status LEDs
- B. Four-digit alphanumeric display
- C. Programming buttons

Global Headquarters

Emerson Automation Solutions
6021 Innovation Blvd.
Shakopee, MN 55379, USA

📞 +1 800 999 9307 or +1 952 906 8888
📠 +1 952 949 7001
✉️ RFQ.RMD-RCC@Emerson.com

Latin America Regional Office

Emerson Automation Solutions
1300 Concord Terrace, Suite 400
Sunrise, FL 33323, USA

📞 +1 954 846 5030
📠 +1 954 846 5121
✉️ RFQ.RMD-RCC@Emerson.com

Asia Pacific Regional Office

Emerson Automation Solutions
1 Pandan Crescent
Singapore 128461

📞 +65 6777 8211
📠 +65 6777 0947
✉️ Enquiries@AP.Emerson.com

North America Regional Office

Emerson Automation Solutions
8200 Market Blvd.
Chanhassen, MN 55317, USA

📞 +1 800 999 9307 or +1 952 906 8888
📠 +1 952 949 7001
✉️ RMT-NA.RCCRF@Emerson.com

Europe Regional Office

Emerson Automation Solutions Europe
GmbH
Neuhofstrasse 19a P.O. Box 1046
CH 6340 Baar
Switzerland

📞 +41 (0) 41 768 6111
📠 +41 (0) 41 768 6300
✉️ RFQ.RMD-RCC@Emerson.com

Middle East and Africa Regional Office

Emerson Automation Solutions
Emerson FZE P.O. Box 17033
Jebel Ali Free Zone - South 2
Dubai, United Arab Emirates

📞 +971 4 8118100
📠 +971 4 8865465
✉️ RFQ.RMTMEA@Emerson.com

 [Linkedin.com/company/Emerson-Automation-Solutions](https://www.linkedin.com/company/Emerson-Automation-Solutions)

 [Twitter.com/Rosemount_News](https://twitter.com/Rosemount_News)

 [Facebook.com/Rosemount](https://www.facebook.com/Rosemount)

 [Youtube.com/user/RosemountMeasurement](https://www.youtube.com/user/RosemountMeasurement)

 [Google.com/+RosemountMeasurement](https://www.google.com/+RosemountMeasurement)

©2019 Emerson. All rights reserved.

Emerson Terms and Conditions of Sale are available upon request. The Emerson logo is a trademark and service mark of Emerson Electric Co. Rosemount is mark of one of the Emerson family of companies. All other marks are the property of their respective owners.