

Rosemount® 8712EM Transmitter with Modbus Protocol



1 Safety

WARNING!

- Failure to follow these installation guidelines could result in serious injury or death.
- Installation and servicing instructions are for use by qualified personnel only. Do not perform any servicing other than that contained in the operating instructions, unless qualified.
- Rosemount Magnetic Flowmeters ordered with non-standard paint options or non-metallic labels may be subject to electrostatic discharge. To avoid electrostatic charge build-up, do not rub the flowmeter with a dry cloth or clean with solvents.
- Verify that the operating environment of the sensor and transmitter is consistent with the appropriate Agency Approval.
- If installed in an explosive atmosphere, verify that the device certification and installation techniques are suitable for that particular environment.
- To prevent ignition of flammable or combustible atmosphere, disconnect power before servicing circuits.
- Explosion hazard—Do not disconnect equipment when a flammable or combustible atmosphere is present.
- Do not connect a Rosemount Transmitter to a non-Rosemount sensor when installed in an “Ex” environment, explosive atmosphere, hazardous area, or classified area.
- Follow national, local, and plant standards to properly earth ground the transmitter and sensor. The earth ground must be separate from the process reference ground.

CAUTION!

- In cases where high voltage/high current are present near the meter installation, ensure proper protection methods are followed to prevent stray voltage/current from passing through the meter. Failure to adequately protect the meter could result in damage to the transmitter and lead to meter failure.
- Completely remove all electrical connections from both sensor and transmitter prior to welding on the pipe. For maximum protection of the sensor, consider removing it from the pipeline.

2 Introduction

This document provides basic installation guidelines for the Rosemount 8712EM wall-mount transmitter.

- For sensor installation refer to the *Rosemount® 8700 Magnetic Flowmeter Sensor Quick Installation Guide*
- For additional installation information, configuration, maintenance, and troubleshooting, refer to the *Rosemount® 8712EM Transmitter with Modbus Protocol Reference Manual*

All user documentation can be found at www.emerson.com. For more contact information see [Section 2.2](#).

2.1 Return policy

Emerson procedures must be followed when returning equipment. These procedures ensure legal compliance with government transportation agencies and help provide a safe working environment for Emerson employees. Failure to follow Emerson procedures will result in your equipment being refused delivery.

2.2 Emerson Flow customer service

Email:

- Worldwide: flow.support@emerson.com
- Asia-Pacific: APflow.support@emerson.com

Telephone:

North and South America		Europe and Middle East		Asia Pacific	
United States	800 522 6277	U.K.	0870 240 1978	Australia	800 158 727
Canada	+1 303 527 5200	The Netherlands	+31 (0) 704 136 666	New Zealand	099 128 804
Mexico	+41 (0) 41 7686 111	France	0800 917 901	India	800 440 1468
Argentina	+54 11 4837 7000	Germany	0800 182 5347	Pakistan	888 550 2682
Brazil	+55 15 3413 8000	Italy	8008 77334	China	+86 21 2892 9000
Venezuela	+58 26 1731 3446	Central & Eastern	+41 (0) 41 7686 111	Japan	+81 3 5769 6803
		Russia/CIS	+7 495 981 9811	South Korea	+82 2 3438 4600
		Egypt	0800 000 0015	Singapore	+65 6 777 8211
		Oman	800 70101	Thailand	001 800 441 6426
		Qatar	431 0044	Malaysia	800 814 008
		Kuwait	663 299 01		
		South Africa	800 991 390		
		Saudi Arabia	800 844 9564		
		UAE	800 0444 0684		

3 Pre-installation

Before installing the transmitter, there are several pre-installation steps that should be completed to make the installation process easier:

- Identify options and configurations that apply to your application
- Set the hardware switches if necessary
- Consider mechanical, electrical, and environmental requirements

Note

Refer to the product reference manual for more detailed requirements.

Identify options and configurations

The typical transmitter installation includes a device power connection, a Modbus RS-485 output connection, and sensor coil and electrode connections. Other applications may require one or more of the following configurations or options:

- Pulse output
- Discrete input/discrete output

Hardware switches

The transmitter has two user-selectable hardware switches. These switches set the internal/external pulse power and transmitter security. The standard configuration for these switches when shipped from the factory is as follows:

Table 3-1: Hardware switch default settings

Setting	Factory configuration
Internal/external pulse power	External
Transmitter security	Off

The internal/external pulse power switch is not available when ordered with intrinsically safe output, ordering code B.

In most cases, it is not necessary to change the setting of the hardware switches. If the switch settings need to be changed, refer to the product reference manual.

Be sure to identify any additional options and configurations that apply to the installation. Keep a list of these options for consideration during the installation and configuration procedures.

Mechanical considerations

The mounting site for the transmitter should provide enough room for secure mounting, easy access to conduit entries, full opening of the transmitter covers, and easy readability of the Local Operator Interface (LOI) screen (if equipped).

Figure 3-1: Rosemount 8712EM Dimensional Drawing

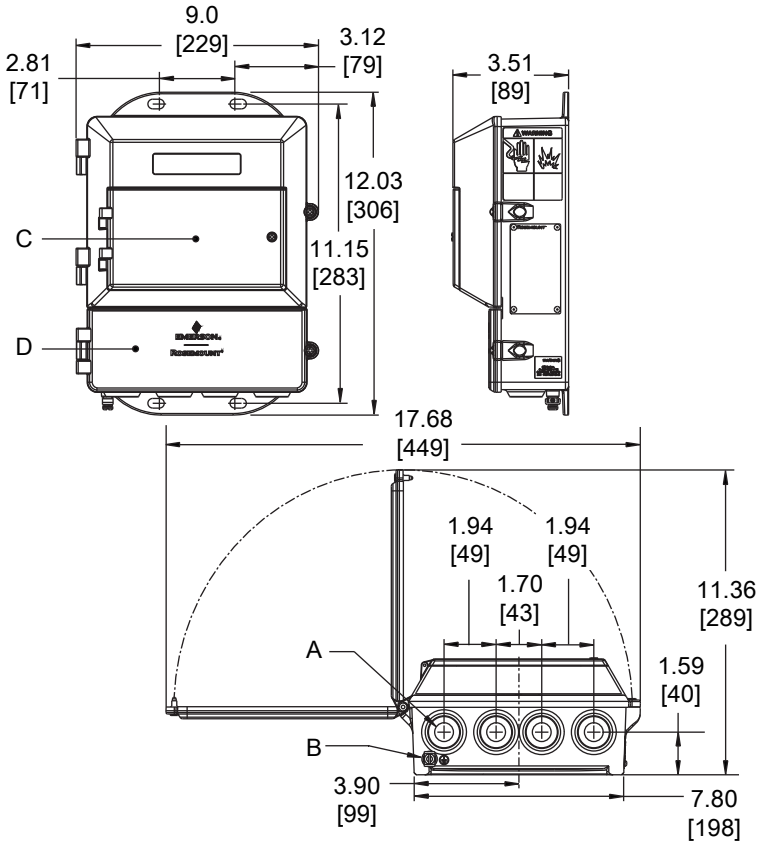

- A. Conduit entry, 1/2-14 NPT (4 places)
- B. Ground lug
- C. LOI keypad cover
- D. Lower cover opens for electrical connections

Note

Dimensions are in inches [Millimeters]

Electrical considerations

Before making any electrical connections to the transmitter, consider national, local, and plant electrical installation requirements. Be sure to have

the proper power supply, conduit, and other accessories necessary to comply with these standards.

The transmitter requires external power. Ensure access to a suitable power source.

Table 3-2: Electrical data

Rosemount 8712EM Flow Transmitter	
Power input	AC power: 90–250VAC, 0.45A, 40VA
	Standard DC power: 12–42VDC, 1.2A, 15W
	Low power DC: 12–30VDC, 0.25A, 4W
Pulsed circuit	Internally powered (Active): Outputs up to 12VDC, 12.1mA, 73mW Externally powered (Passive): Input up to 28VDC, 100mA, 1W
Modbus output circuit	Internally powered (Active): Outputs up to 3.3VDC, 100mA, 100mW
Termination resistors	Typically 120 ohms. Refer to the MODBUS over Serial Line Specification & Implementation Guide (http://www.modbus.org) for more details.
Um	250V
Coil excitation output	500mA, 40V max, 9W max

Environmental considerations

To ensure maximum transmitter life, avoid extreme temperatures and excessive vibration. Typical problem areas include the following:

- Tropical or desert installations in direct sunlight
- Outdoor installations in arctic climates

Remote mounted transmitters may be installed in the control room to protect the electronics from the harsh environment and to provide easy access for configuration or service.

4 Mounting

Wall mount transmitters are shipped with mounting hardware for use on a 2-in. pipe or flat surface.

Figure 4-1: Mounting bracket

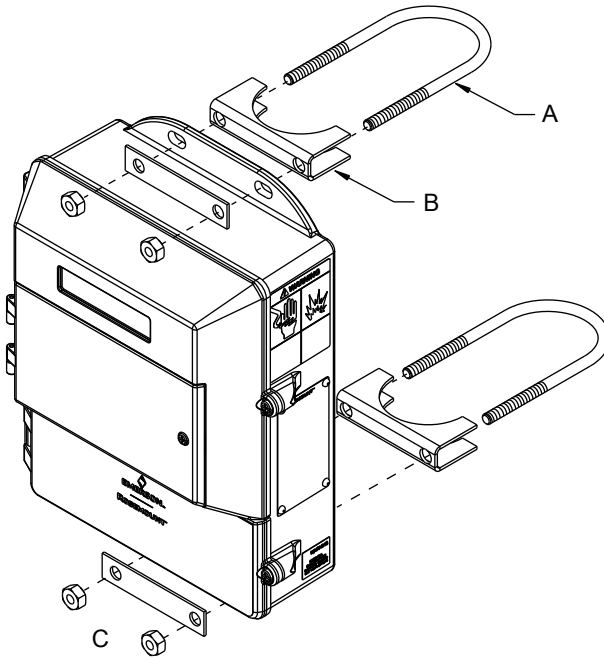

- A. U-bolt
- B. Saddle clamp
- C. Fasteners

4.1 Pipe mounting

1. Attach the saddle clamp to the pipe using the U-bolt mounting hardware.
2. Attach the transmitter to the saddle clamp assembly with appropriate fasteners.

4.2 Surface mounting

Attach the transmitter to the mounting location using customer supplied mounting screws. The installation of the transmitter shall be rated for four (4) times the weight of the transmitter or 44lbs (20kgs).

5 Wiring

5.1 Conduit entries and connections

Transmitter conduit entries ports are ½"-14NPT as standard, M20 conduit connections will use an adapter. Conduit connections should be made in accordance with national, local, and plant electrical codes. Unused conduit entries should be sealed with the appropriate certified plugs. The plastic shipping plugs do not provide ingress protection.

5.2 Conduit requirements

- For installations with an intrinsically safe electrode circuit, a separate conduit for the coil cable and the electrode cable may be required. Refer to the product reference manual.
- For installations with non-intrinsically safe electrode circuit, or when using the combination cable, a single dedicated conduit run for the coil drive and electrode cable between the sensor and the remote transmitter may be acceptable. Removal of the barriers for intrinsic safety isolation is permitted for non-intrinsically safe electrode installations.
- Bundled cables from other equipment in a single conduit are likely to create interference and noise in the system. See [Figure 5-1](#).
- Electrode cables should not be run together in the same cable tray with power cables.
- Output cables should not be run together with power cables.
- Select conduit size appropriate to feed cables through to the flowmeter.

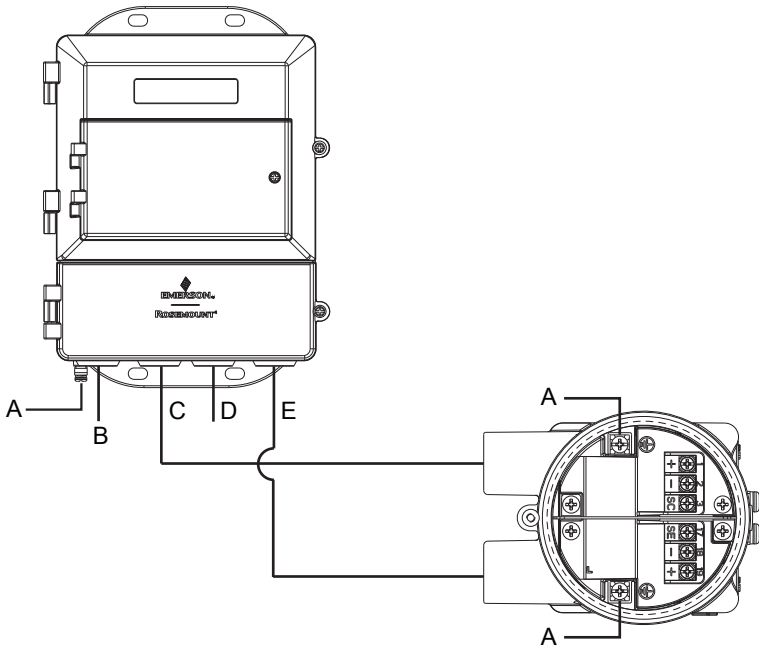
Figure 5-1: Best practice conduit preparation

- A. Safety ground
- B. Power
- C. Coil
- D. Output
- E. Electrode

5.3 Sensor to transmitter wiring

Wiring details

Cables kits are available as individual component cables or as a combination coil/electrode cable. Remote cables can be ordered directly using the kit numbers shown in [Table 5-1](#), [Table 5-2](#), and [Table 5-3](#). Equivalent Alpha cable part numbers are also provided as an alternative. To order cable, specify length as quantity desired. Equal length of component cables is required.

Examples:

- 25 feet = Qty (25) 08732-0065-0001
- 25 meters = Qty (25) 08732-0065-0002

Table 5-1: Component cable kits - standard temperature (-20°C to 75°C)

Cable kit #	Description	Individual cable	Alpha p/n
08732-0065-0001 (feet)	Kit, component cables, Std temp (includes Coil and Electrode)	Coil Electrode	2442C 2413C
08732-0065-0002 (meters)	Kit, component cables, Std temp (includes Coil and Electrode)	Coil Electrode	2442C 2413C
08732-0065-0003 (feet)	Kit, component cables, Std temp (includes Coil and I.S. Electrode)	Coil Intrinsically Safe Blue Electrode	2442C Not available
08732-0065-0004 (meters)	Kit, component cables, Std temp (includes Coil and I.S. Electrode)	Coil Intrinsically Safe Blue Electrode	2442C Not available

Table 5-2: Component cable kits - extended temperature (-50°C to 125°C)

Cable kit #	Description	Individual cable	Alpha p/n
08732-0065-1001 (feet)	Kit, Component Cables, Ext Temp. (includes Coil and Electrode)	Coil Electrode	Not available Not available
08732-0065-1002 (meters)	Kit, Component Cables, Ext Temp. (includes Coil and Electrode)	Coil Electrode	Not available Not available
08732-0065-1003 (feet)	Kit, Component Cables, Ext Temp. (includes Coil and I.S. Electrode)	Coil Intrinsically Safe Blue Electrode	Not available Not available
08732-0065-1004 (meters)	Kit, Component Cables, Ext Temp. (includes Coil and I.S. Electrode)	Coil Intrinsically Safe Blue Electrode	Not available Not available

Table 5-3: Combination cable kits - coil and electrode cable (-20°C to 80°C)

Cable kit #	Description
08732-0065-2001 (feet)	Kit, Combination Cable, Standard
08732-0065-2002 (meters)	
08732-0065-3001 (feet)	Kit, Combination Cable, Submersible (80°C dry/60°C Wet) (33ft Continuous)
08732-0065-3002 (meters)	

Cable requirements

Shielded twisted pairs or triads must be used. For installations using the individual coil drive and electrode cable, see [Figure 5-2](#). Cable lengths should be limited to less than 500 feet (152 m). Consult factory for length between 500–1000 feet (152–304 m). Equal length cable is required for each. For installations using the combination coil drive/electrode cable, see [Figure 5-3](#). Combination cable lengths should be limited to less than 330 feet (100 m).

Figure 5-2: Individual component cables

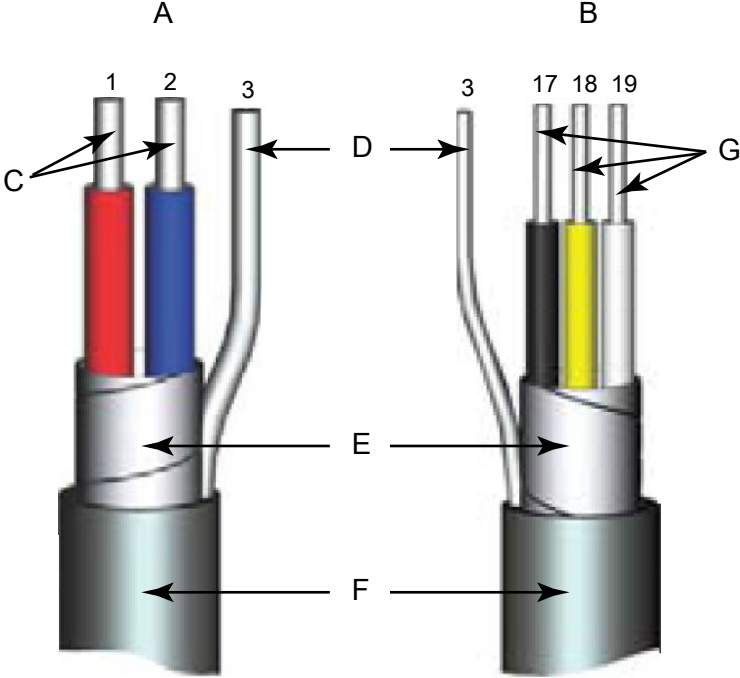

- A. Coil drive
- B. Electrode
- C. Twisted, stranded, insulated 14 AWG conductors
- D. Drain
- E. Overlapping foil shield
- F. Outer jacket
- G. Twisted, stranded, insulated 20 AWG conductors
- 1 = Red
- 2 = Blue
- 3 = Drain
- 17 = Black
- 18 = Yellow
- 19 = White

Figure 5-3: Combination coil and electrode cable

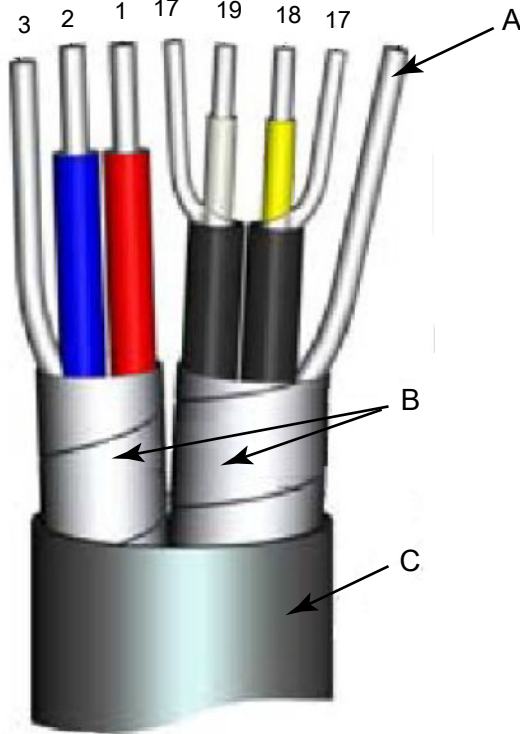

- A. *Electrode shield drain*
- B. *Overlapping foil shield*
- C. *Outer jacket*
- 1 = Red
- 2 = Blue
- 3 = Drain
- 17 = Reference
- 18 = Yellow
- 19 = White

Cable preparation

Prepare the ends of the coil drive and electrode cables as shown in [Figure 5-4](#). Remove only enough insulation so that the exposed conductor fits completely under the terminal connection. Best practice is to limit the unshielded length (D) of each conductor to less than one inch. Excessive

removal of insulation may result in an unwanted electrical short to the transmitter housing or other terminal connections. Excessive unshielded length, or failure to connect cable shields properly, may also expose the unit to electrical noise, resulting in an unstable meter reading.

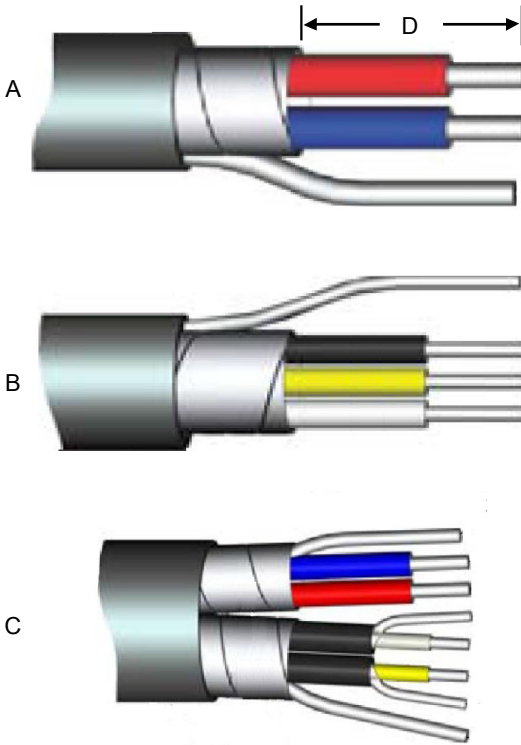
Figure 5-4: Cable ends

- A. Coil
- B. Electrode
- C. Combination
- D. Unshielded length

⚠ WARNING!

Shock hazard! Potential shock hazard across remote junction box terminals 1 and 2 (40V).

⚠ WARNING!

Explosion hazard! Electrodes exposed to process. Use only compatible transmitter and approved installation practices. For process temperatures greater than 284°F (140°C), use a wire rated for 257°F (125°C).

Remote junction box terminal blocks

Figure 5-5: Remote junction box views

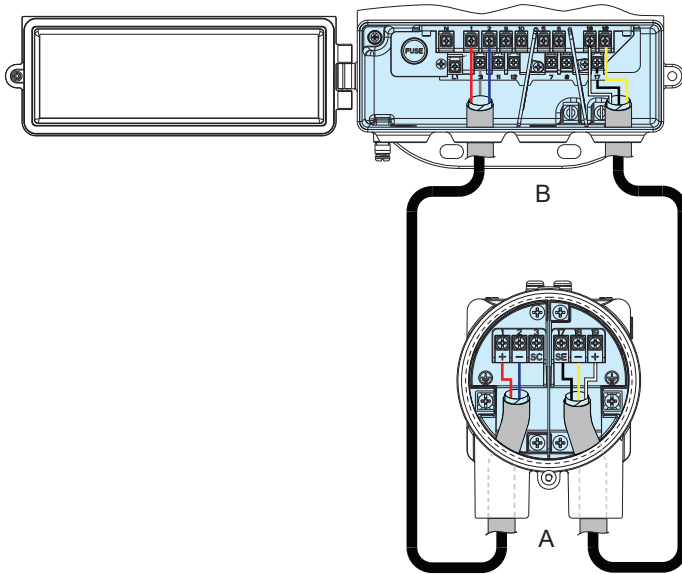

- A. Sensor
- B. Transmitter

Table 5-4: Sensor/transmitter wiring

Wire color	Sensor terminal	Transmitter terminal
Red	1	1
Blue	2	2
Shield	3 or Float	3
Black	17	17
Yellow	18	18
White	19	19

Note

For hazardous locations, refer to the product reference manual.

5.5 Power and I/O terminal blocks

Open the bottom cover of the transmitter to access the terminal block.

Note

To connect pulse output and/or discrete input/output, and for installations with intrinsically safe outputs, refer to the product reference manual.

Figure 5-8: 8712EM Terminal blocks

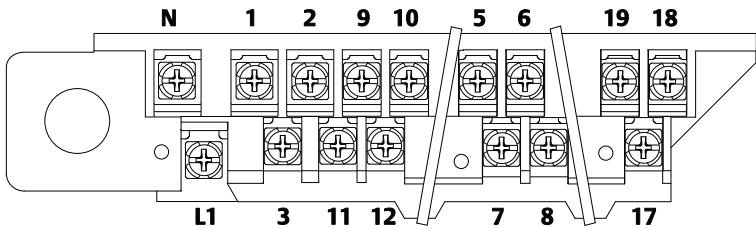

Table 5-5: 8712EM Power and I/O terminals

Terminal number	AC version	DC version
1	Coil Positive	Coil Positive
2	Coil Negative	Coil Negative
3	Coil Shield	Coil Shield
5	+ Pulse	+ Pulse
6	- Pulse	- Pulse
7	Modbus A	Modbus A
8	Modbus B	Modbus B
9 ⁽¹⁾	+ Discrete In/Out 2	+ Discrete In/Out 2
10 ⁽¹⁾	- Discrete In/Out 2	- Discrete In/Out 2
11 ⁽¹⁾	+ Discrete In/Out 1	+ Discrete In/Out 1
12 ⁽¹⁾	- Discrete In/Out 1	- Discrete In/Out 1
17	Electrode Reference	Electrode Reference
18	Electrode Negative	Electrode Negative
19	Electrode Positive	Electrode Positive
N	AC (Neutral)/L2	DC (-)
L1	AC L1	DC (+)

(1) Only available with ordering code AX.

5.6 Powering the transmitter

The transmitter is available in three models. The AC powered transmitter is designed to be powered by 90–250VAC (50/60Hz). The DC powered transmitter is designed to be powered by 12–42VDC. The low power transmitter is designed to be powered by 12–30VDC. Before connecting power to the transmitter, be sure to have the proper power supply, conduit, and other accessories. Wire the transmitter according to national, local, and plant electrical requirements for the supply voltage.

If installing in a hazardous location, verify that the meter has the appropriate hazardous area approval. Each meter has a hazardous area approval tag attached to the side of the transmitter housing.

AC power supply requirements

Units powered by 90 - 250VAC have the following power requirements. Peak inrush is 35.7A at 250VAC supply, lasting approximately 1ms. Inrush for other supply voltages can be estimated with: $\text{Inrush (Amps)} = \text{Supply (Volts)} / 7.0$

Figure 5-9: AC current requirements

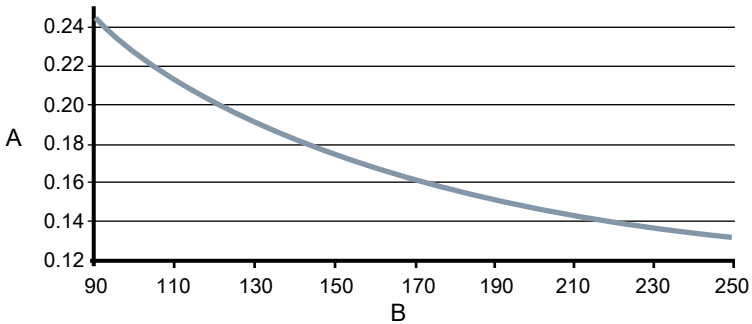

- A. Supply current (amps)
- B. Power supply (VAC)

Figure 5-10: Apparent power

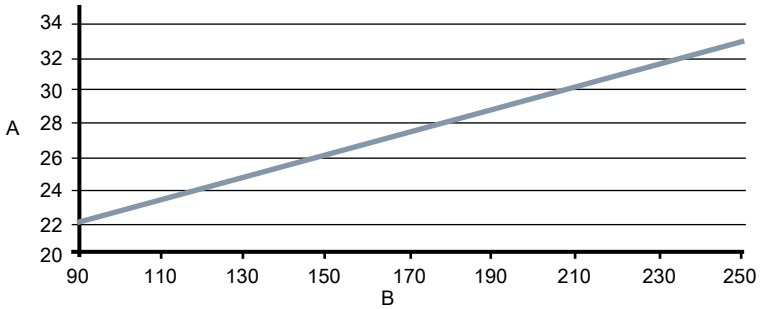

- A. Apparent power (VA)
- B. Power supply (VAC)

DC power supply requirements

Standard DC units powered by 12VDC power supply may draw up to 1.2A of current steady state. Low power DC units may draw up to 0.25A of current steady state. Peak inrush is 42A at 42VDC supply, lasting approximately 1ms. Inrush for other supply voltages can be estimated with: $\text{Inrush (Amps)} = \text{Supply (Volts)} / 1.0$

Figure 5-11: DC current requirements

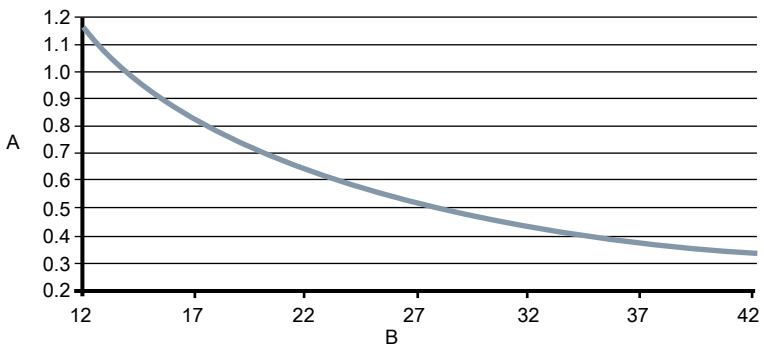

- A. Supply current (amps)
- B. Power supply (VDC)

Figure 5-12: Low power DC current requirements

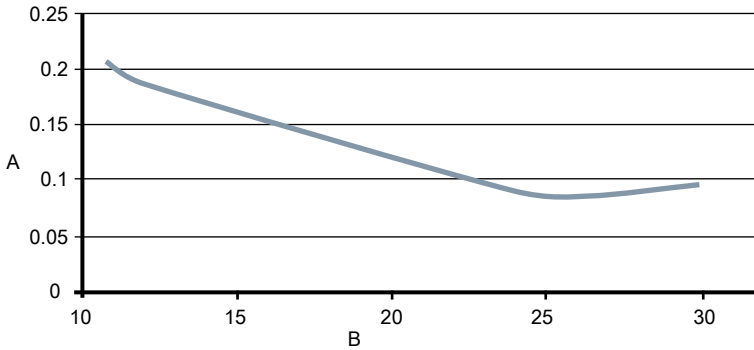

- A. Supply current (amps)
- B. Power supply (VDC)

Supply wire requirements

Use 10–18 AWG wire rated for the proper temperature of the application. For wire 10–14 AWG use lugs or other appropriate connectors. For connections in ambient temperatures above 122 °F (50 °C), use a wire rated for 194 °F (90 °C). For DC powered transmitters with extended cable lengths, verify that there is a minimum of 12VDC at the terminals of the transmitter with the device under load.

Electrical disconnect requirements

Connect the device through an external disconnect or circuit breaker per national and local electrical code.

Installation category

The installation category for the transmitter is OVERVOLTAGE CAT II.

Overcurrent protection

The transmitter requires overcurrent protection of the supply lines. Fuse rating and compatible fuses are shown in [Table 5-6](#).

Table 5-6: Fuse requirements

Power system	Power supply	Fuse rating	Manufacturer
AC power	90–250VAC	2 Amp quick acting	Bussman AGC2 or equivalent
DC power	12–42VDC	3 Amp quick acting	Bussman AGC3 or equivalent

Table 5-6: Fuse requirements (continued)

Power system	Power supply	Fuse rating	Manufacturer
DC low power	12–30VDC	3 Amp quick acting	Bussman AGC3 or equivalent

Power terminals

For AC powered transmitter (90–250VAC, 50/60 Hz):

- Connect AC Neutral to Terminal N and AC Line to Terminal L1.

For DC powered transmitter:

- Connect negative to Terminal N and positive to Terminal L1.
- DC powered units may draw up to 1.2A.

Covers

Use the transmitter lower door screw to secure the terminal compartment after the instrument has been wired and powered up. Follow these steps to ensure the housing is properly sealed to meet ingress protection requirements:

1. Ensure all wiring is complete and close the lower door.
2. Tighten the lower door screw until the lower door is tight against the housing. Metal to metal contact of the screw bosses is required to ensure a proper seal.

Note

Application of excessive torque may strip the threads or break the screw.

3. Verify the lower door is secure.

5.7 Modbus output

The Modbus output is a Modbus RTU signal using RS-485. Follow these cable recommendations for RS-485 interface (Modbus over serial line).

Cable characteristics

Type	Shielded twisted pair cable with 2 conductors and a drain wire, or Ethernet cable of Cat 5/5e/6
Conductor gauge	20–24 AWG for lengths up to 1000 feet 16–20 AWG for lengths up to 4000 feet

Characteristic impedance	100–130 ohm
Conductor-to-conductor capacitance	<30 pF/ft
Conductor-to-shield capacitance	<60 pF/ft
Voltage rating	300 V/600 V
Recommended insulation material	PVC (<1000 ft) or PE (\geq 1000 ft)

Bus cable

- Bus to be connected device to device. For example, daisy chained (not star connected).
- Maximum 4000 feet depending on speeds, cable, and loads.
- Cable shield must be grounded at only one point.
- Due to the use of galvanically isolated Modbus connections, a third common wire is not necessary for this product. If a 3-conductor cable is used, the third wire should be left unterminated and insulated from ground.

Derivations (spurs)

Avoid derivations (spurs) when possible. If required, derivations from the bus must be as short as possible (65 feet maximum).

Termination

A single 120 ohm terminator should be placed at each physical end of the bus (at the two most remote bus devices) to minimize reflections in the transmission cable. Do not place terminators on a spur connection.

Modbus wiring

- The Modbus signal is a 24VDC active output.
- Wire terminal 7 (A/D0) and terminal 8 (B/D1). See [Figure 5-13](#).

Figure 5-13: Modbus output wiring

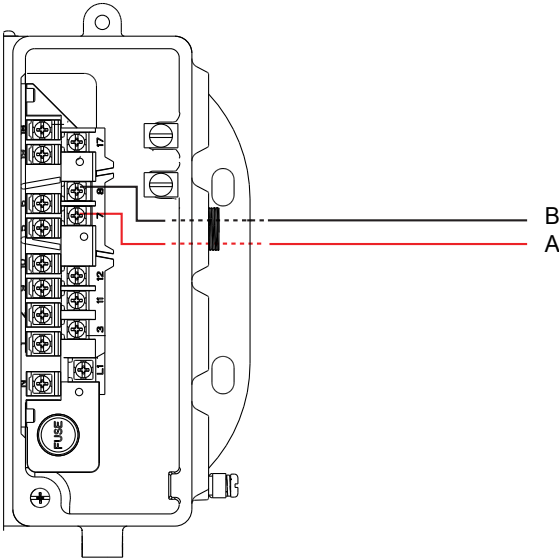

- A. Modbus A/D0
- B. Modbus B/D1

6 Basic configuration

Once the magnetic flowmeter is installed and power has been supplied, the transmitter must be configured through the basic setup. These parameters can be configured through either an LOI or a Modbus host. Configuration settings are saved in nonvolatile memory within the transmitter. Descriptions of more advanced functions are included in the product reference manual.

6.1 Local operator interface (LOI)

To access the transmitter menu, press the XMTR MENU key. Use the UP, DOWN, LEFT(E), and RIGHT arrows to navigate the menu structure. A complete map of the LOI menu structure is shown in the product reference manual.

The display can be locked to prevent unintentional configuration changes. The display lock can be activated by holding the UP arrow for three seconds and then following the on-screen instructions.

When the display lock is activated, a lock symbol will appear in the lower right hand corner of the display. To deactivate the display lock, hold the UP arrow for three seconds and follow the on-screen instructions. Once deactivated, the lock symbol will no longer appear in the lower right hand corner of the display.

6.2 Modbus configuration

Each register is identified by its address (or starting address). Depending on the PLC that will be used to communicate with the transmitter, you may need to subtract 1 from the address or starting address of the register. Refer to your PLC documentation to know if this applies to you.

Address (register 109)

Configures the address of the transmitter for the Modbus network.

Floating point byte order (register 110)

Sets the order that information is sent by the transmitter.

Register value	Byte order
0	0-1-2-3 (default)
1	2-3-0-1
2	1-0-3-2
3	3-2-1-0

Baud rate (register 115)

Sets the communication speed of the transmitter.

Register value	Baud rate
0	1200
1	2400
2	4800
3	9600
4	19200 (default)
5	38400
6	57600
7	115200

Parity (register 116)

Used to configure error-checking methodology for the data.

Register value	Parity
0	No parity
1	Odd
2	Even (default)

Stop bits (register 117)

Sets the last bit of the data packet.

Register value	Stop bits
1	1 bit (default)
2	2 bits

6.3 Basic setup

Tag (registers 68–71)

Tag is the quickest and shortest way of identifying and distinguishing between transmitters. Transmitters can be tagged according to the requirements of your application. The tag may be up to eight characters long.

Flow units (register 61)

The flow units variable specifies the format in which the flow rate will be displayed. Units should be selected to meet your particular metering needs.

Table 6-1: Volume units

Register value	Units
241	Barrels (31 gal)/sec
242	Barrels (31 gal)/min
243	Barrels (31 gal)/hour
244	Barrels (31 gal)/day
132	Barrels (42 gal)/sec
133	Barrels (42 gal)/min
134	Barrels (42 gal)/hour
135	Barrels (42 gal)/day
248	Cubic cm/minute
26	Cubic feet/second
15	Cubic feet/minute
130	Cubic feet/hour
27	Cubic feet/day
28	Cubic meters/second
131	Cubic meters/minute
19	Cubic meters/hour
29	Cubic meters/day
22	Gallons/second
16	Gallons/minute
136	Gallons/hour
23	Millions gallons/day
235	Gallons/day
137	Imperial gallons/sec
18	Imperial gallons/min
30	Imperial gallons/hour
31	Imperial gallons/day
24	Liters/second
17	Liters/minute
138	Liters/hour
240	Liters/day

Table 6-2: Mass units

Register value	Units
73	Kilograms/second

Table 6-2: Mass units (continued)

Register value	Units
74	Kilograms/minute
75	Kilograms/hour
76	Kilograms/day
77	Metric ton/minute
78	Metric ton/hour
79	Metric ton/day
80	Pounds/second
81	Pounds/minute
82	Pounds/hour
83	Pounds/day
84	Short tons/minute
85	Short tons/hour
86	Short tons/day

Table 6-3: Other units

Register value	Units
20	Feet/second (default)
21	Meters/second
253	Special units ⁽¹⁾

(1) Refer to the product reference manual.

Line size (register 65)

The line size (sensor size) must be set to match the actual sensor connected to the transmitter.

Register value	Line size
0	0.10-in. (2 mm)
1	0.15-in. (4 mm)
2	0.25-in. (6 mm)
3	0.30-in. (8 mm)
4	0.50-in. (15 mm)
5	0.75-in. (18 mm)
6	1-in. (25 mm)
7	1.5-in. (40 mm)
8	2-in. (50 mm)
9	2.5-in. (65 mm)
10	3-in. (80 mm) (default)

Register value	Line size
11	4-in. (100 mm)
12	5-in. (125 mm)
13	6-in. (150 mm)
14	8-in. (200 mm)
15	10-in. (250 mm)
16	12-in. (300 mm)
17	14-in. (350 mm)
18	16-in. (400 mm)
19	18-in. (450 mm)
20	20-in. (500 mm)
21	24-in. (600 mm)
22	28-in. (700 mm)
23	30-in. (750 mm)
24	32-in. (800 mm)
25	36-in. (900 mm)
26	40-in. (1000 mm)
27	42-in. (1050 mm)
28	44-in. (1100 mm)
29	48-in. (1200 mm)
30	54-in. (1350 mm)
31	56-in. (1400 mm)
32	60-in. (1500 mm)
33	64-in. (1600 mm)
34	66-in. (1650 mm)
35	72-in. (1800 mm)
36	78-in. (1950 mm)

Calibration number (registers 413–420)

The sensor calibration number is a 16-digit number generated at the factory during flow calibration and is unique to each sensor and is located on the sensor tag.



Quick Start Guide
00825-0400-4445, rev. AB
November 2017

Emerson Automation Solutions USA

7070 Winchester Circle
Boulder, Colorado USA 80301
T +1 303-527-5200
T +1 800-522-6277
F +1 303-530-8459
www.emerson.com

Emerson Automation Solutions Europe

Neonstraat 1
6718 WX Ede
The Netherlands
T +31 (0) 70 413 6666
F +31 (0) 318 495 556
www.micromotion.nl

Emerson Automation Solutions Asia

1 Pandan Crescent
Singapore 128461
Republic of Singapore
T +65 6777-8211
F +65 6770-8003

Emerson Automation Solutions Japan

1-2-5, Higashi Shinagawa
Shinagawa-ku
Tokyo 140-0002 Japan
T +81 3 5769-6803
F +81 3 5769-6844

Emerson Automation Solutions United Kingdom

Emerson Process Management Limited
Horsfield Way
Bredbury Industrial Estate
Stockport SK6 2SU U.K.
T +44 0870 240 1978
F +44 0800 966 181

©2017 Rosemount, Inc. All rights reserved.

The Emerson logo is a trademark and service mark of Emerson Electric Co. Rosemount, 8600, 8700, 8800 marks are marks of one of the Emerson Automation Solutions family of companies. All other marks are property of their respective owners.