

# Rosemount™ 0085 Pipe Clamp Sensor Assembly



Safety messages

**⚠ WARNING**

**Physical access**

Unauthorized personnel may potentially cause significant damage to and/or misconfiguration of end users' equipment. This could be intentional or unintentional and needs to be protected against.

Physical security is an important part of any security program and fundamental in protecting your system. Restrict physical access by unauthorized personnel to protect end users' assets. This is true for all systems used within the facility.

**⚠ CAUTION**

**Conduit/cable entries**

Unless otherwise marked, the conduit/cable entries in the housing enclosure use a 1/2- NPT form. Only use plugs, adapters, glands, or conduit with a compatible thread form when closing these entries.

Entries marked M20 are M20 x 1.5 thread form. On devices with multiple conduit entries, all entries will have the same thread form.

When installing in a hazardous location, use only appropriately listed or Ex certified plugs, glands, or adapters in cable/conduit entries.

**Contents**

About this guide..... 3

Exploded view drawings..... 4

Location and orientation..... 7

Installation..... 12

Installing optional accessories..... 21

Rosemount X-well™ Technology considerations..... 23

Product certifications..... 25

Declaration of Conformity..... 31

China RoHS..... 33

Specifications ..... 34

# 1 About this guide

This guide provides basic guidelines for Rosemount 0085 Pipe Clamp Sensor. It does not provide instructions for configuration, diagnostics, maintenance, service, troubleshooting, explosion-proof, flameproof, or intrinsically safe (I.S.) installations.

If the Rosemount 0085 Sensor was ordered assembled to a temperature transmitter, see the appropriate Quick Start Guide for information on configuration and hazardous locations certifications.

## **Related information**

[Emerson.com/Rosemount](https://emerson.com/Rosemount)

## 2 Exploded view drawings

Figure 2-1: Rosemount 0085 Universal Pipe Mount exploded view

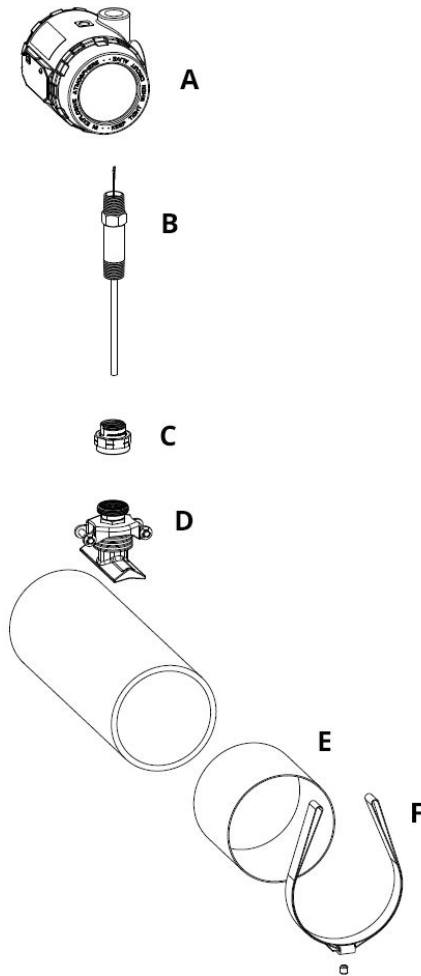

- A. Transmitter
- B. Sensor with spring-loaded adapter
- C. Nipple union
- D. Universal Pipe Mount
- E. Corrosion protection inlay (optional)
- F. Banding

**Figure 2-2: Rosemount 0085 Pipe Clamp Sensor Assembly exploded view (Updated 2024 Design)**

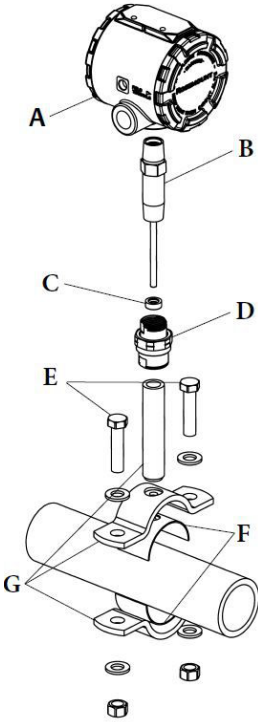

- A. Transmitter
- B. Sensor with spring-loaded adapter
- C. Wiper seal
- D. Nipple union of the extension
- E. Mounting hardware
- F. Corrosion protection inlay (optional)
- G. Pipe clamp & extension

**Figure 2-3: Rosemount 0085 Pipe Clamp Sensor Assembly exploded view (Legacy Design)**

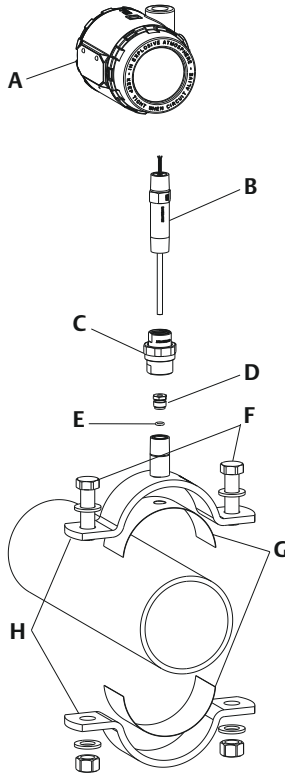

- A. *Transmitter*
- B. *Sensor with spring-loaded adapter*
- C. *Nipple union of the extension*
- D. *Nut*
- E. *O-ring*
- F. *Mounting hardware*
- G. *Corrosion protection inlay (optional)*
- H. *Pipe clamp*

### 3 Location and orientation

- The pipe clamp sensor should be mounted on the outside section of the pipe where the process medium is in contact of the inside of the pipe wall.
- Ensure that the pipe surface is clean of debris.
- The pipe clamp sensor should be mounted in a secure position to ensure there is no rotational movement after installation.
- To ensure ingress protection, the nut of the Rosemount 0085 Pipe Clamp sensor can be tightened to a torque of 2 lbf · in to compress the O-ring to form a seal. The nut can be accessed and tightened by removing the sensor and the nipple union of the extension. Refer to the [Exploded view drawings](#) for the location of each part.

### 3.1 Horizontal orientation

Though the Rosemount 0085 Pipe Clamp Sensor can be mounted in any orientation for full pipe flow applications, the best practice is to mount the pipe clamp sensor on the upper half of the pipe.

**Figure 3-1: Horizontal Orientation**

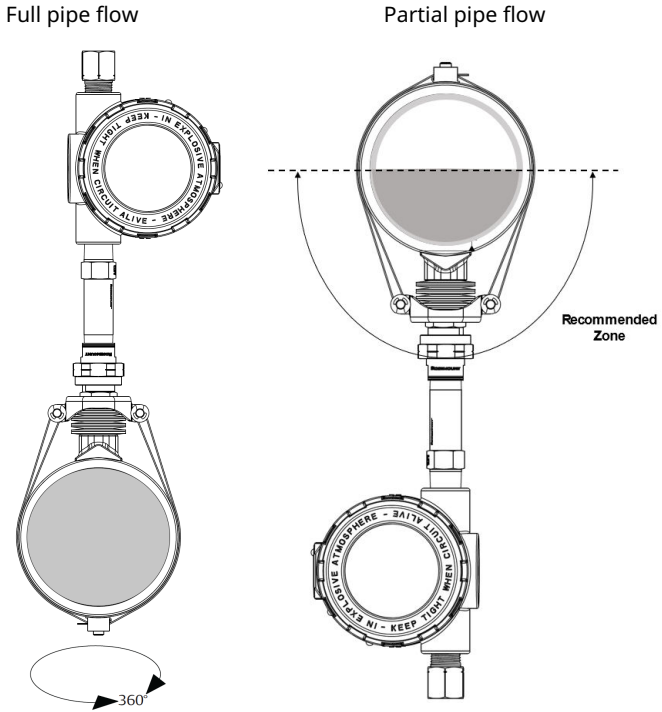



### 3.2 Vertical orientation

The pipe clamp sensor can be installed in any position around the circumference of the pipe.

**Figure 3-2: Vertical Orientation**

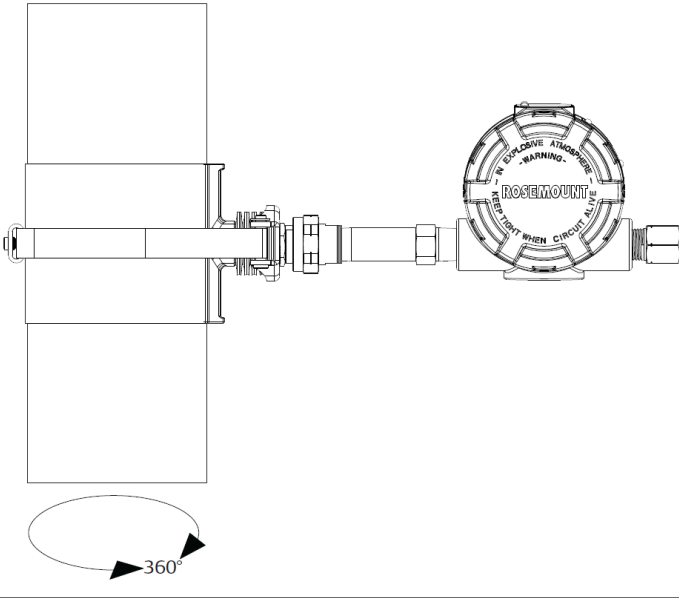

### 3.3 Special considerations

Under most circumstances, the Rosemount 0085 Pipe Clamp Sensor can be mounted in a direct mount configuration. Since heat from the process is transferred from the pipe clamp sensor to the transmitter housing, if the expected process temperature is near or beyond specification limits, consider using a remote mount configuration to isolate the transmitter from the process. Refer to the appropriate transmitter reference manual for temperature effects.

**Figure 3-3: Pipe Clamp Sensor Assembly in Remote Mount Configuration**

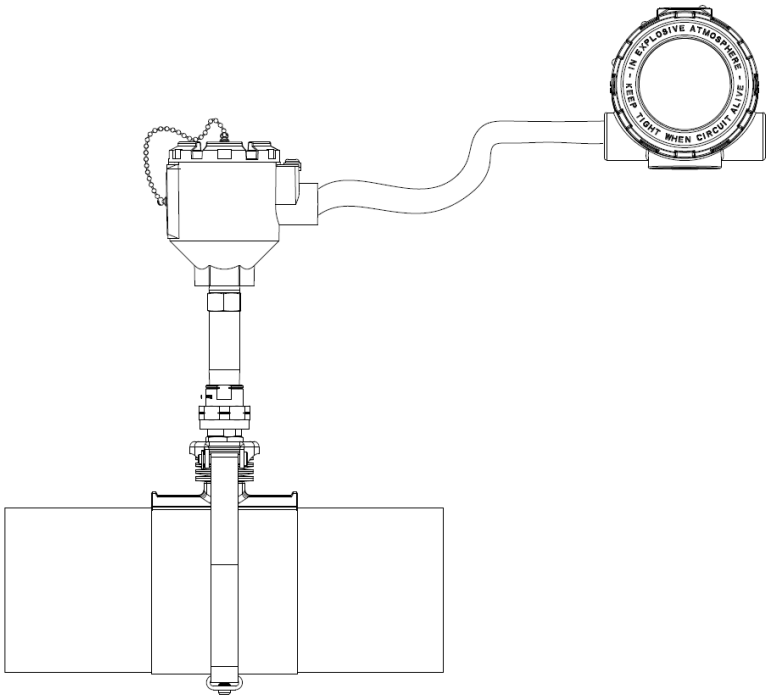

Wireless transmitters with external antennas allow for multiple antenna configurations. All wireless transmitters should be appropriately 3 ft. (1 m) from any large structure or building to allow clear communication to other devices. Wireless transmitters with external antennas should be positioned vertically, either straight up or straight down.

**Figure 3-4: Wireless Transmitter Orientation**

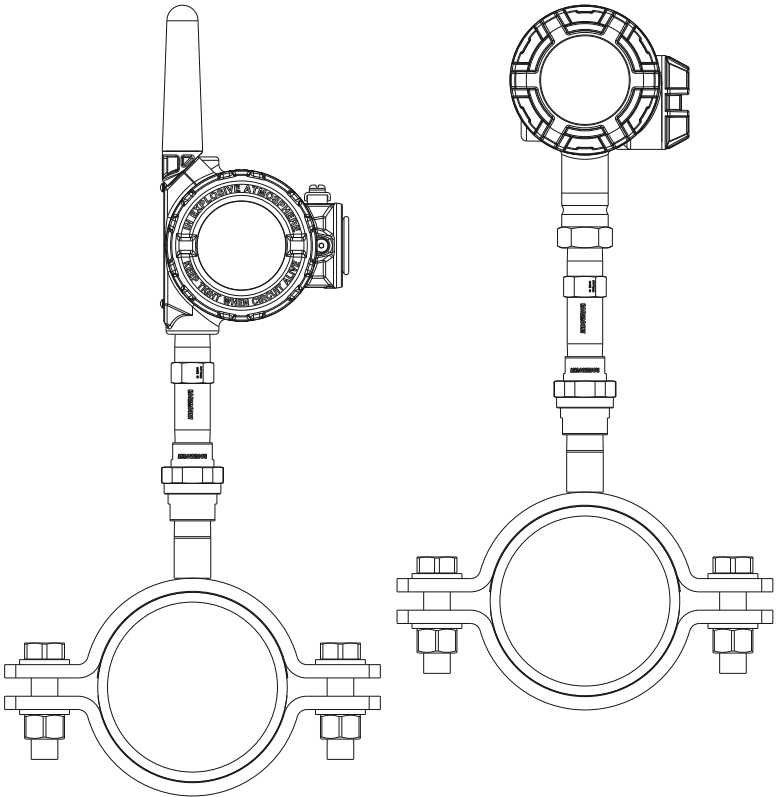

## 4 Installation

Select the area for 0085 installation with the recommendations outlined in Horizontal orientation. Start with [Install Universal Pipe Mount](#) or [Install pipe clamp sensor](#) depending on style of 0085 Pipe Clamp Sensor Assembly that has been ordered.

### 4.1 Install Universal Pipe Mount

#### Prerequisites

The tools required for installation are:

- Hand-crack banding tensioner tool
- 4 mm Allen wrench
- 15/16 inch or 24 mm open-ended wrench



Universal Pipe Mount  
Installation Video

#### **⚠ CAUTION**

Emerson recommends wearing safety glasses and gloves during this process.

---

**Figure 4-1: Universal Pipe Mount Component Overview:**

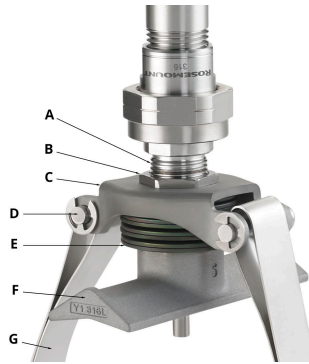

- A. Threaded stem
- B. Tension nut
- C. Tensioner plate
- D. Removable tension rods
- E. Springs
- F. Mount foot
- G. Banding and buckle

**Procedure**

1. Place clamp and banding on pipe.

Place the mount foot onto the pipe surface, then run the banding around the pipe and through the inside of the tensioner plate, making sure that the screw side of the buckle is facing inward, as shown.



2. Loose install of banding.

Bend the banding down around the rods of the tensioner plate. The end of the band with the buckle attached should be bent at a length that allows the buckle to sit near the bottom side of the pipe, opposite to the clamp assembly. Acceptable location for the buckle is anywhere on the lower half of the pipe, opposite to the clamp. The buckle must not fall within the distance between the tensioner plate and the pipe.

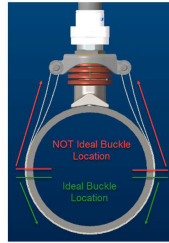

3. Temporarily secure banding.

Wrap the free end of the band around the pipe and through the buckle. Fold back loose end at least 90° to temporarily secure the band in place. Then pull the banding snug and bend it so that it is perpendicular to the pipe.



4. Prepare banding for tensioning.

Place banding within tensioner tool. Place nose of tensioner tool against the buckle, and slide banding into tool.

---

**Note**

The position of the clamp assembly may be moved after the banding has been tensioned, so the clamp does not need to be in the final position during this step. Emerson recommends that the clamp be positioned to allow for the most ergonomic use of the tensioner tool for this step.

---

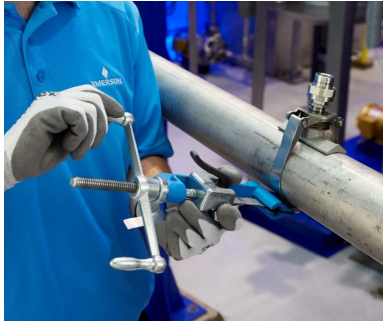

5. Tension banding and clamp.

Turn the crank on the tensioner tool to tighten the banding. This will slowly compress the tensioner plate and spring. The banding should be tightened until the entire black indicator mark is visible on the threaded stem. If the environment makes it difficult to see this indicator mark, the proper installation distance between the tension plate and top of tension nut should be set at 0.32 inches, or 8.1 mm.

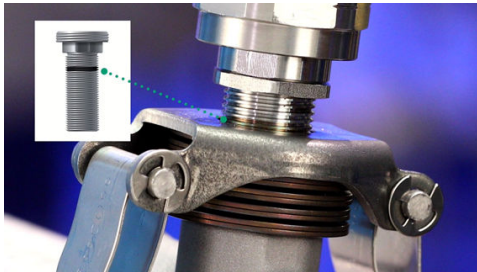

6. Lock banding and tighten buckle.

Using a 4 mm Allen wrench, tighten the set screw on the buckle to lock the banding in place.



7. Remove tension tool.

Once the banding is secured, reduce tension on the tensioner tool by spinning the crank counter-clockwise, and remove the tool. Then bend the loose end of the banding over top of the buckle.

---

**Note**

Emerson recommends leaving enough length of banding to allow for re-tensioning of the banding if ever necessary. If you choose to trim any excess banding, be sure to remove any sharp edges or burs.

---

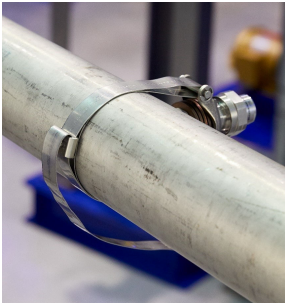



#### 8. Final positioning.

With the banding tensioned, the clamp assembly may now be moved to its desired location. Using a 15/16-in or 24 mm open-ended wrench, turn the tension nut clockwise on the threaded stem until it contacts the tensioner plate. Continue to tighten the tension nut to compress the springs until the banding loses tension and the clamp may be freely moved around the pipe.

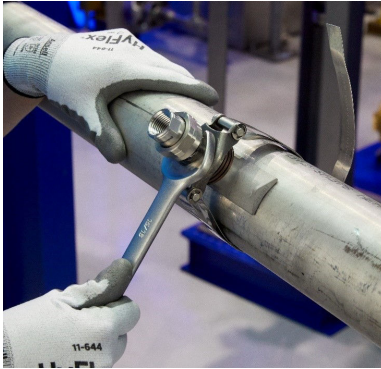

#### 9. Finalize installation location and tension.

Once the Universal Pipe Mount is in its desired position, loosen the tension nut to decompress the spring to return tension to the banding. When loosening, return the tension nut to the top of the threaded stem.



## 4.2 Uninstall and reinstall Universal Pipe Mount

### Procedure

1. Using a 15/16 inch or 24 mm open ended wrench, turn the tension nut clockwise on the threaded stem until it contacts

the tensioner plate. Continue to tighten the tension nut to compress the springs until the banding loses tension and the clamp may be freely moved around the pipe.

- Using a pliers, pull off each e-clip, and slide out each tension rod from the tensioner plate to remove the banding loop from the assembly. Reattach the tension rods and e-clips to the tensioner plate.

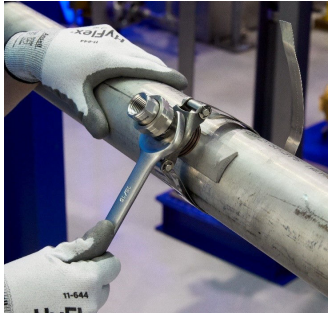

- If reinstalling on the same pipe, reverse these steps to reassemble the Universal Pipe Mount and formed banding loop. If reinstalling on a new pipe, follow the standard installation instructions with a new set of banding.

### 4.3 Install pipe clamp sensor

Mount the pipe clamp sensor on the pipe and tighten the bolts. Ensure the sensor passes through the hole of the pipe clamp and has direct contact between the sensor tip and pipe. Refer to [Figure 4-2](#) for more information. Tighten the bolts to secure the pipe clamp sensor to the pipe.

---

### Figure 4-2: Sensor Tip and Pipe Contact

Correct

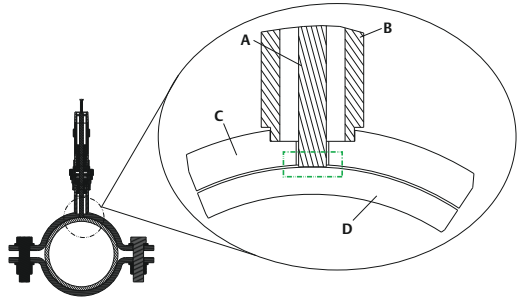

Incorrect

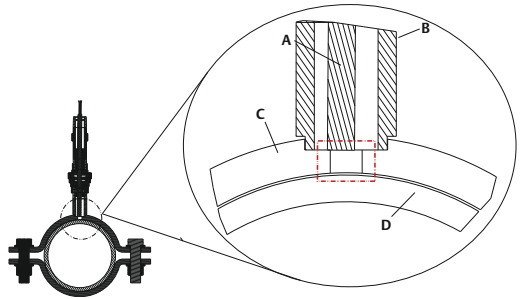

- A. Sensor
- B. Extension of pipe clamp
- C. Pipe clamp
- D. Pipe

---

## 4.4 Install transmitter

See appropriate transmitter reference manual for sensor-transmitter installation.

**Figure 4-3: Sensor Lead Wire Termination**

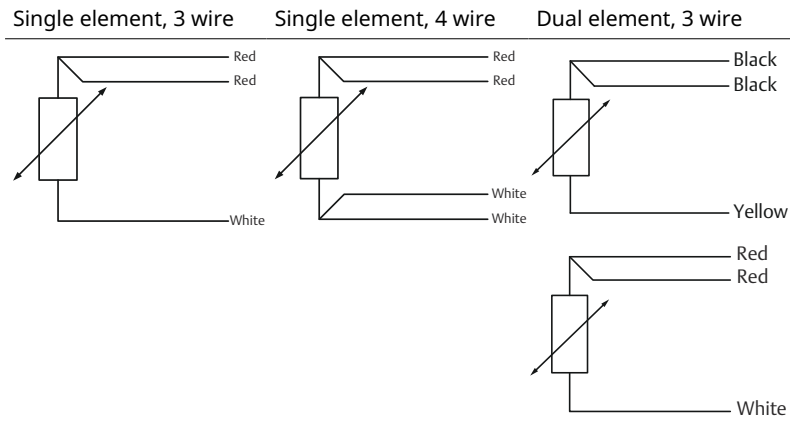

## 4.5 Commission transmitter

See appropriate transmitter reference manual for transmitter commissioning instructions.

## 5 Installing optional accessories

### Corrosion protection inlay

The corrosion protection inlay provides a layer of protection to help minimize the possibility of dissimilar metal corrosion between the pipe clamp and pipe. The inlay is installed in between the pipe clamp and the pipe. Ensure the sensor is clearing the hole in the protection inlay after installation.

**Figure 5-1: Pipe Clamp Sensor Assembly with Protection Inlay**

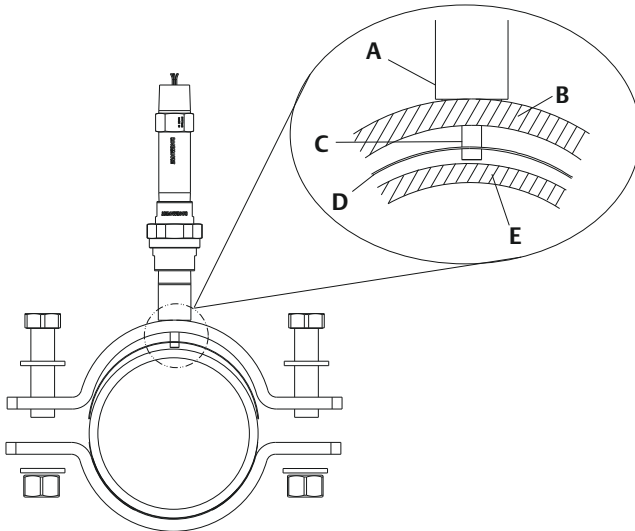

- A. Extension of pipe clamp
- B. Pipe clamp
- C. Sensor
- D. Corrosion protection inlay
- E. Pipe

### 5.1 Replacement sensor

Procedure for replacing the spring-loaded sensor in the pipe clamp sensor.

The spring-loaded sensor can be ordered for replacement using the [Rosemount 0085 Pipe Clamp Sensor Product Data Sheet](#).

**Procedure**

1. Loosen and remove the original sensor from the extension of the pipe clamp.
2. Add pipe compound or PTFE tape (where local piping codes allow) to the threads of the new sensor.
3. Insert the new sensor into the extension of the pipe clamp sensor and ensure the sensor tip passes through the hole of the pipe clamp.
4. Screw in the sensor and tighten to 24 ft-lbs of torque.

## 6 Rosemount X-well™ Technology considerations

Rosemount X-well Technology is for temperature monitoring applications and is not intended for control or safety applications. It is available in the Rosemount 3144P Temperature Transmitter and 648 Wireless Temperature Transmitter in a factory assembled direct mount configuration with a Rosemount 0085 Pipe Clamp Sensor. It cannot be used in a remote mount configuration.

Rosemount X-well Technology will only work as specified with factory supplied and assembled Rosemount 0085 Pipe Clamp silver tipped single element sensor with an 80 mm extension length. It will not work as specified if used with other sensors. Installation and use of an incorrect sensor will result in inaccurate process temperature calculations.

---

### Note

It is extremely important the above requirements and installation steps are followed to ensure Rosemount X-well Technology works as specified.

---

In general, pipe clamp sensor installation best practices must be followed (see [Location and orientation](#) ), as well as the specific Rosemount X-well Technology requirements noted below:

- Direct mounting of the transmitter on a pipe clamp sensor is required for Rosemount X-well Technology to properly function. [Figure 6-1](#) displays a transmitter/pipe clamp assembly that is in a direct mount configuration.
- 

**Figure 6-1: Pipe Clamp Sensor Assembly in Direct Mount Configuration**

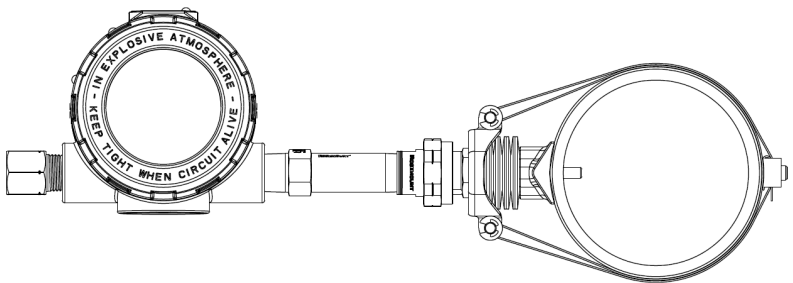

- Assembly must be installed away from dynamic external temperature sources such as a boiler or heat tracing.

- The pipe clamp sensor makes direct contact with the pipe surface. Moisture buildup between the sensor and the pipe surface or the sensor hangup in the assembly can cause inaccurate process temperature calculations. Refer to [Install pipe clamp sensor](#) for more information on proper sensor to pipe surface contact.
- Insulation at least ½-in. thick (with R-value of  $> 0.42 \text{ m}^2 \times \text{K/W}$ ) is required over the sensor clamp assembly and the sensor extension up to the transmitter head to prevent heat loss. Apply a minimum of six inches of insulation on each side of the pipe clamp sensor.

---

**Note**

Care should be taken to minimize air gaps between insulation and pipe. See [Figure 6-2](#) for more information.

---

**Figure 6-2: Pipe Clamp Insulation**

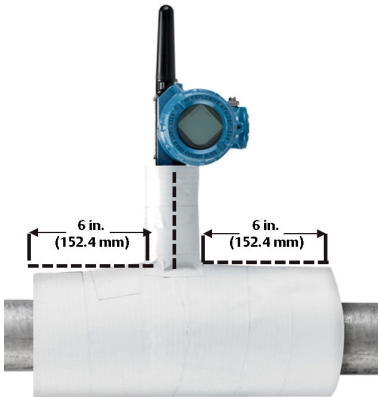

---

**NOTICE**

DO NOT apply insulation over the transmitter head.

---

- Although it will come from the factory configured as such, ensure that the pipe clamp RTD sensor is assembled in the correct wire configuration. Refer to the appropriate transmitter reference manual for correct wire configurations.



## 7 Product certifications

To view current 0085 Pipe Clamp Sensor Product certifications, see the [0085 Pipe Clamp Sensor Assembly Quick Start Guide](#).

### 7.1 European Directive Information

A copy of the EU Declaration of Conformity can be found at the end of the Quick Start Guide. The most recent revision of the EU Declaration of Conformity can be found at [Emerson.com/Rosemount](https://www.emerson.com/Rosemount).

### 7.2 Ordinary Location Certification

As standard, the transmitter has been examined and tested to determine that the design meets the basic electrical, mechanical, and fire protection requirements by a nationally recognized test laboratory (NRTL) as accredited by the Federal Occupational Safety and Health Administration (OSHA).

### 7.3 North America

The US National Electrical Code® (NEC) and the Canadian Electrical Code (CEC) permit the use of Division marked equipment in Zones and Zone marked equipment in Divisions. The markings must be suitable for the area classification, gas, and temperature class. This information is clearly defined in the respective codes.

### 7.4 North America

#### E5 USA Explosionproof

**Certificate:** 70044744

**Standards:** FM Class 3600:2011, FM Class 3611:2004, FM Class 3615:2006, UL 50E:2020, UL 61010-1:2012 AMD1:2018, ANSI/UL 121201-2021 Ninth Edition

**Markings:** XP CL I, DIV 1, GP B, C, D; NI CL 1 DIV 2, GP A, B, C, D; T6 (-50 °C ≤ T<sub>a</sub> ≤ +80 °C), T5 (-50 °C ≤ T<sub>a</sub> ≤ +95 °C); Seal not required; installed per Rosemount drawing 00068-0033; Type 4x; V<sub>max</sub> 35 VDC, 750 mW<sub>max</sub>

#### E6 Canada Explosionproof

**Certificate:** 70044744

**Standards:** CAN/CSA C22.2 No. 30-M1986 (R2012), CAN/CSA C22.2 No. 94.2:2020, CAN/CSA C22.2 No. 213:2017 UPD 1:2018 UPD2:2019 UPD3:2021, CAN/CSA C22.2 No. 61010-1:2012 UPD1:2015 UPD2:2016 AMD1:2018

**Markings:** XP CL I, DIV 1, GP B, C, D; NI CL 1 DIV 2, GP A, B, C, D; T6 (-50 °C ≤ T<sub>a</sub> ≤ +80 °C), T5 (-50 °C ≤ T<sub>a</sub> ≤ +95 °C); Seal not required; installed per Rosemount drawing 00068-0033; Type 4x; V<sub>max</sub> 35 VDC, 750 mW<sub>max</sub>

## 7.5 Europe

### E1 ATEX Flameproof

**ATEX Certificate:** DEKRA 19ATEX0076X

**Standards:** EN IEC 60079-0:2018, EN 60079-1:2014

**Markings:**  II 2 G Ex db IIC T6...T1 Gb

### Special Conditions for Safe Use (X):

1. Flameproof joints are not intended for repair.
2. Non-Standard Paint options may cause risk from electrostatic discharge. Avoid installations that cause electrostatic build-up on painted surfaces, and only clean the painted surfaces with a damp cloth. If paint is ordered through a special option code, contact the manufacturer for more information.
3. When provided on their own, the adapter style sensors must be assembled to a suitable Ex db enclosure with a free internal volume no greater than 550 cm<sup>3</sup>.

Process temperature range (°C) <sup>1</sup>	Ambient temperature range (°C) <sup>1</sup>	Temperature class
-60 °C to +80 °C	-60 °C to +80 °C	T6
-60 °C to +95 °C	-60 °C to +80 °C	T5
-60 °C to +130 °C	-60 °C to +80 °C	T4
-60 °C to +195 °C	-60 °C to +80 °C	T3
-60 °C to +290 °C	-60 °C to +80 °C	T2
-60 °C to +440 °C	-60 °C to +80 °C	T1

### I1 ATEX Intrinsic Safety

**Certificate:** Baseefa16ATEX0101X

**Standards:** EN 60079-0:2018, EN 60079-11:2012

**Markings:**  II 1 G Ex ia IIC T5/T6 Ga SEE CERTIFICATE FOR SCHEDULE

Thermocouples; P <sub>i</sub> = 500 mW	T6 -60 °C ≤ T <sub>a</sub> ≤ +70 °C
RTDs; P <sub>i</sub> = 192 mW	T6 -60 °C ≤ T <sub>a</sub> ≤ +70 °C
RTDs; P <sub>i</sub> = 290 mW	T6 -60 °C ≤ T <sub>a</sub> ≤ +60 °C
	T5 -60 °C ≤ T <sub>a</sub> ≤ +70 °C

**Special Condition for Safe Use (X):**

The equipment must be installed in an enclosure which affords it a degree of ingress protection of at least IP20.

## 7.6 International

### E7 IECEx Flameproof

- Certificate:** IECEx DEK 19.0041X
- Standards:** IEC 60079-0:2017, IEC 60079-1:2014
- Markings:** Ex db IIC T6...T1 Gb

**Special Conditions for Safe Use (X):**

1. Flameproof joints are not intended for repair.
2. Non-Standard Paint options may cause risk from electrostatic discharge. Avoid installations that cause electrostatic build-up on painted surfaces, and only clean the painted surfaces with a damp cloth. If paint is ordered through a special option code, contact the manufacturer for more information.
3. When provided on their own, the adapter style sensors must be assembled to a suitable Ex db enclosure with a free internal volume no greater than 550 cm<sup>3</sup>.

Process temperature range (°C) <sup>1</sup>	Ambient temperature range (°C) <sup>1</sup>	Temperature class
-60 °C to +80 °C	-60 °C to +80 °C	T6
-60 °C to +95 °C	-60 °C to +80 °C	T5
-60 °C to +130 °C	-60 °C to +80 °C	T4
-60 °C to +195 °C	-60 °C to +80 °C	T3
-60 °C to +290 °C	-60 °C to +80 °C	T2
-60 °C to +440 °C	-60 °C to +80 °C	T1

## 7.7 EAC

### EM Explosionproof/Flameproof

**Markings:** 1Ex db IIC T6...T1 Gb X; T6 (-55 °C to 40 °C), T5...T1 (-55 °C to 60 °C)

#### Special Condition for Safe Use (X):

See certificate.

### IM Intrinsic Safety

**Markings:** 0Ex ia IIC T5/T6 Ga X; T5,  $P_i = 0.29 \text{ W}$ , (-60 °C to +70 °C); T6,  $P_i = 0.29 \text{ W}$ , (-60 °C to +60 °C); T6,  $P_i = 0.192 \text{ W}$ , (-60 °C to +70 °C)

#### Special Condition for Safe Use (X):

See certificate.

## 7.8 Korea

### EP Explosionproof/Flameproof

**Certificate:** 22-KA4BO-0072X

**Markings:** Ex db IIC T6...T1 Gb; T6(-60 °C ≤  $T_{amb}$  ≤ +70 °C), T5...T1(-60 °C ≤  $T_{amb}$  ≤ +80 °C)

#### Special Condition for Safe Use (X):

See certificate for special conditions for safe use.

## 7.9 China

### E3 China Flameproof 隔爆和粉尘防爆

**证书:** GYJ20.1393X (CCC 认证)

**所用标准:** GB3836.1 – 2010, GB3836.2 – 2010, GB12476.1-2013, GB12476.5-2013

**标志:** Ex d IIC T1...T6 Gb

#### 特殊使用条件(X):

1. 涉及隔爆接合面的维修须联系产品制造商。
2. 铭牌材质为非金属，使用时须防止产生静电火花，只能用湿布清理。

使用注意事项

1. 产品温度组别和防爆标志及使用环境温度之间的关系为：

防爆标志	温度组别	使用环境温度
Ex d II C T1~T6 Gb	T6	-50 °C ~ +40 °C
	T1~T5	-50 °C ~ +60 °C

2. 产品温度组别和过程温度之间的关系为：

温度组别	T6	T5	T4	T3	T2	T1
过程温度 (°C)	85	100	135	200	300	450

3. 产品外壳设有接地端子，用户在使用时应可靠接地。
4. 安装现场应不存在对产品外壳有腐蚀作用的有害气体。
5. 用户不得自行更换该产品的零部件，应会同产品制造商共同解决运行中出现的故障，以杜绝损坏现象的发生。
6. 产品的安装、使用和维护应同时遵守产品使用说明书、GB3836.13-2013“爆炸性环境 第 13 部分：设备的修理、检修、修复和改造”、GB/T3836.15-2017“爆炸性环境 第 15 部分：电气装置的设计、选型和安装”、GB/T3836.16-2017“爆炸性环境 第 16 部分：电气装置的检查与维护”和 GB50257-2014“电气装置安装工程爆炸和火灾危险环境电力装置施工及验收规范”和 GB15577-2018“粉尘防爆安全规程”的有关规定。

## 7.10 Y3 ATEX/IECEX RFID tag approvals

<b>Certificate</b>	IECEX EPS 15.0042X, EPS 15 ATEX 1 1011 X
<b>Markings</b>	II 2G Ex ia IIC T6/T4 Gb, II 2D Ex ia IIC T80/T130C Db

### Conditions of certification

Maximum operating temperature: -58 °F (-50 °C) to +158 °F (+70 °C)

The RFID tags shall never be exposed to high electromagnetic field strengths according to IEC 60079-14.

Electrostatic charges shall be avoided. The tags shall never be used next to strong charge generating processes.

**⚠ WARNING****Additional warnings**



The plastic enclosure may present a potential electrostatic ignition hazard.



RFID tag has limitations in ambient temperature and zone installation areas (Zones 1 & 21) as compared to the transmitter.

---

# 8 Declaration of Conformity

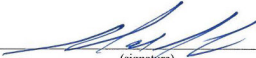
Figure 8-1: Rosemount 0085 Pipe Clamp Sensor Declaration of Conformity

	<b>EU Declaration of Conformity</b> No: RMD 1109 Rev. G	
We,		
<b>Rosemount, Inc.</b> 6021 Innovation Boulevard Shakopee, MN 55379-4676 USA		
declare under our sole responsibility that the product,		
<b>Rosemount™ 65, 85, 185, and 214C Temperature Sensors</b>		
manufactured by,		
<b>Rosemount, Inc.</b> 6021 Innovation Boulevard Shakopee, MN 55379-4676 USA		
to which this declaration relates, is in conformity with the provisions of the European Union Directives, including the latest amendments, as shown in the attached schedule.		
Assumption of conformity is based on the application of the harmonized standards and, when applicable or required, a European Union notified body certification, as shown in the attached schedule.		
 _____ (signature)	Vice President of Global Quality _____ (function)	
Mark Lee _____ (name)	<i>October 22, 2021</i> _____ (date of issue)	
Page 1 of 2		

	<b>EU Declaration of Conformity</b> No: RMD 1109 Rev. G	
<b>ATEX Directive (2014/34/EU)</b>		
<b>DEKRA 19ATEX0076 X - Flameproof Certificate</b> Equipment Group II Category 2 G (Ex db IIC T6...T1 Gb) Harmonized Standards: EN IEC 60079-0:2018, EN 60079-1:2014		
<b>DEKRA 19ATEX0076 X - Dust Certificate</b> Equipment Group II Category 2 D (Ex tb IIIC T130°C Db) Harmonized Standards: EN IEC 60079-0:2018, EN 60079-31:2014		
<b>BAS00ATEX3145 - Type n Certificate</b> Equipment Group II Category 3 G (Ex nA IIC T5 Gc) Harmonized Standards: EN 60079-0:2012+A11:2013 (a review against EN IEC 60079-0:2018, which is harmonized, shows no significant changes relevant to this equipment so EN 60079-0:2012+A11:2013 continues to represent "State of the Art"), EN 60079-15:2010		
<b>Baseefa16ATEX0101X - Intrinsic Safety Certificate</b> Equipment Group II Category 1 G (Ex ia IIC T5/T6 Ga) Harmonized Standards: EN IEC 60079-0:2018, EN 60079-11:2012		
<b>RoHS Directive (2011/65/EU)</b> Harmonized Standard: EN 50581:2012		
<b>ATEX Notified Bodies for EC Type Examination Certificate</b>		
<b>Dekra Certification B.V.</b> [Notified Body Number: 0344] Utrechtseweg 310 Postbus 5185 6802 ED Arnhem Netherlands		
<b>SGS FIMKO OY</b> [Notified Body Number: 0598] Takomotie 8 00380 HELSINKI Finland		
<b>ATEX Notified Body for Quality Assurance</b>		
<b>SGS FIMKO OY</b> [Notified Body Number: 0598] Takomotie 8 00380 HELSINKI Finland		



## 9 China RoHS

含有China RoHS管控物质超过最大浓度限值的部件型号列表 0085 Temperature Sensor  
List of 0085 Temperature Sensor Parts with China RoHS Concentration above MCVs

部件名称 Part Name	有害物质 / Hazardous Substances					
	铅 Lead (Pb)	汞 Mercury (Hg)	镉 Cadmium (Cd)	六价铬 Hexavalent Chromium (Cr +6)	多溴联苯 Polybrominated biphenyls (PBB)	多溴联苯醚 Polybrominated diphenyl ethers (PBDE)
壳体组件 Housing Assembly	○	○	○	○	○	○
传感器组件 Sensor Assembly	○	○	○	○	○	○

本表格系依据SJ/T11364的规定而制作。

This table is proposed in accordance with the provision of SJ/T11364.

○: 意为该部件的所有均质材料中该有害物质的含量均低于GB/T 26572所规定的限量要求。

○: Indicate that said hazardous substance in all of the homogeneous materials for this part is below the limit requirement of GB/T 26572.

X: 意为在该部件所使用的的所有均质材料里，至少有一类均质材料中该有害物质的含量高于GB/T 26572所规定的限量要求。

X: Indicate that said hazardous substance contained in at least one of the homogeneous materials used for this part is above the limit requirement of GB/T 26572.

部件名称 Part Name	组装备件说明 Spare Parts Descriptions for Assemblies
壳体组件 Housing Assembly	电子外壳 Electrical Housing

## 10 Specifications

### Material selection

Emerson provides a variety of Rosemount product with various product options and configurations. This includes Materials of Construction that can be expected to perform well in a wide range of applications.

The Rosemount product information presented is intended as a guide for the purchaser to make an appropriate selection for the application. It is the purchaser's sole responsibility to make a careful analysis of all process parameters when specifying product, materials, options and components for the particular application.

Examples of process parameters include:

- All chemical components
- Temperature
- Pressure
- Flow rate
- Abrasives
- Contaminants

Emerson is not in a position to evaluate or guarantee the compatibility of the process fluid or other process parameters with the product, options, configuration or materials of construction selected.

### 10.1 Rosemount pipe clamp platinum RTD

#### Nominal resistance

In accordance with IEC 60751, the nominal resistance is defined:

100  $\Omega$  RTD at 32 °F (0 °C)

$\alpha = 0.00385 \Omega \times ^\circ\text{C}/\Omega$ , averaged between 32 to 212 °F (0 to 100 °C)

#### Limit deviations

Tolerance Class B, as standard  $t = \pm(0.3 + 0.005 \times [t])$ ; temperature range -328 to 572 °F (-200 to 300 °C)

Tolerance Class A, as option  $t = \pm(0.15 + 0.002 \times [t])$ ; temperature range -58 to 572 °F (-50 to 300 °C)

#### Process temperature range

-58 to 572 °F (-50 to 300 °C)

**Ambient temperature range**

-40 to 185 °F (-40 to 85 °C)

**Self-heating**

0.15 K/mW when measured as defined in IEC 60751

**Insulation resistance**

1,000 MΩ minimum insulation resistance when measured at 500 Vdc at room temperature

**Sheath material**

321 SST with mineral insulated cable construction and silver or nickel tip

**Lead wires**

PTFE insulated, silver-coated copper wire (See [Figure 10-1.](#))

**Identification data**

The model and serial numbers are engraved directly on the spring-loaded adapter.

**Ingress Protection (IP) rating for connection head**

IP68 and NEMA® 4X

**Figure 10-1: Sensor Lead Wire Termination - Pipe Clamp RTD Spring Loaded**

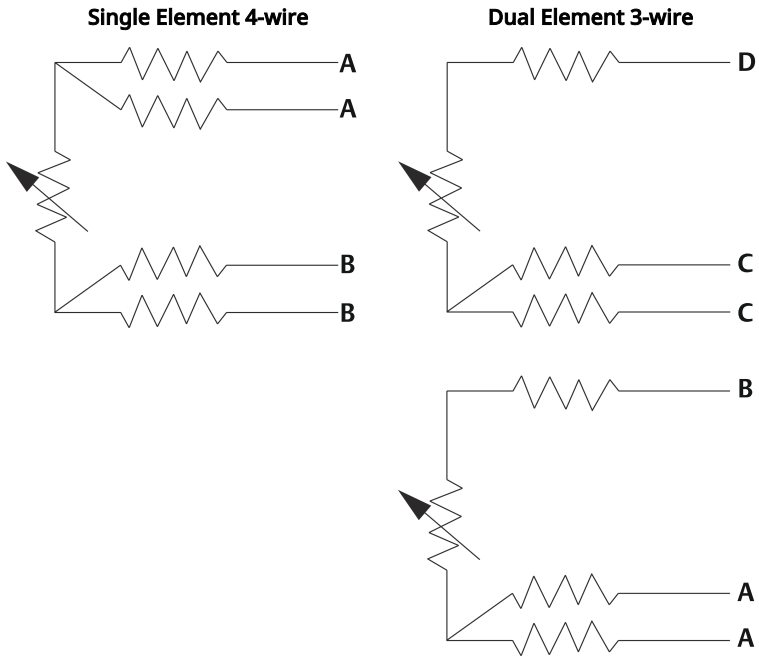

- A. Red
- B. White
- C. Black
- D. Yellow

**Vibration effect**

**Option Codes: P, B, C, S:** No effect on performance per the requirements of IEC 60770-1: 1999 field or pipeline with medium vibration level (10 - 60 Hz 0.075 mm displacement peak amplitude/60-1000 Hz 1g).

**Option Code: U (Universal Pipe Mount):** No effect on performance per the requirements of IEC 60770-1: 2010 field or pipeline with medium vibration level (10 - 60 Hz 0.30 mm displacement peak amplitude/60-1,000 Hz 2g).

## 10.2 Functional specifications

**Power**                      Overvoltage category I

**Environmental**        Pollution degree 4







**Quick Start Guide**  
**00825-0100-4952, Rev. GD**  
**July 2024**

For more information: [Emerson.com/global](https://www.emerson.com/global)

©2024 Emerson. All rights reserved.

Emerson Terms and Conditions of Sale are available upon request. The Emerson logo is a trademark and service mark of Emerson Electric Co. Rosemount is a mark of one of the Emerson family of companies. All other marks are the property of their respective owners.

**ROSEMOUNT™**

