

Rosemount™ 2051 Pressure Transmitter and Rosemount 2051CF Series Flow Meter

with FOUNDATION™ Fieldbus Protocol



Contents

About this guide	3
System readiness.....	5
Mount the transmitter.....	7
Tagging.....	14
Rotate housing.....	15
Set the switches.....	16
Wire, ground, and power up.....	18
Configuration.....	21
Zero trim the transmitter.....	29
Rosemount 2051 product certifications.....	30

1 About this guide

This guide provides basic guidelines for Rosemount 2051 Pressure Transmitters. It does not provide instructions for configuration, diagnostics, maintenance, service, troubleshooting, explosionproof, flameproof, or intrinsically safe (I.S.) installations. Refer to the [Rosemount 2051 Pressure Transmitter Reference Manual](#) for more instructions. This guide is also available electronically at Emerson.com.

1.1 Safety messages

▲ WARNING

Explosions could result in death or serious injury.

Installation of these transmitters in an explosive environment must be in accordance with the appropriate local, national, and international standards, codes, and practices. Review the approvals section of the Rosemount 2051 Reference Manual for any restrictions associated with a safe installation.

In an explosionproof/flameproof installation, do not remove the transmitter covers when power is applied to the transmitter.

Process leaks could result in death or serious injury.

To avoid process leaks, only use the O-ring designed to seal with the corresponding flange adapter.

Electrical shock could cause death or serious injury.

Avoid contact with the leads and terminals. High voltage that may be present on leads can cause electrical shock.

Conduit/cable entries

Unless marked, the conduit/cable entries in the housing use a ½-14 NPT thread form. Entries marked *M20* are M20 × 1.5 thread form. On devices with multiple conduit entries, all entries will have the same thread form. Only use plugs, adapters, glands, or conduit with a compatible thread form when closing these entries.

⚠ WARNING**Physical access**

Unauthorized personnel may potentially cause significant damage to and/or misconfiguration of end users' equipment. This could be intentional or unintentional and needs to be protected against.

Physical security is an important part of any security program and fundamental in protecting your system. Restrict physical access by unauthorized personnel to protect end users' assets. This is true for all systems used within the facility.

2 System readiness

Note

Before installing the transmitter, confirm the correct device driver is loaded on the host systems.

2.1 Confirm correct device driver

- Verify the correct device driver (DD/DTM™) is loaded on your systems to ensure proper communications.
- Download the correct device driver at your host vendor download site, [Emerson.com/DeviceInstallKits](https://www.emerson.com/DeviceInstallKits), or [FieldCommGroup.org](https://www.fieldcommgroup.org).

2.1.1 Device revisions and drivers

Table 2-1 provides the information necessary to ensure you have the correct device driver and documentation for your device.

Table 2-1: Rosemount 2051 FOUNDATION™ Fieldbus device revisions and files

Device revision (1)	Host	Device driver (DD) ⁽²⁾	Obtain at	Device driver (DTM)	Reference document
2	All	DD4: DD Rev 1	FieldComm Group	Emerson.com	00809-0200-41 01, Rev BA or newer
	All	DD5: DD Rev 1	FieldComm Group		
	Emerson	AMS Device Manager V 10.5 or higher: DD Rev 2	Emerson.com		
	Emerson	AMS Device Manager V 8 to 10.5: DD Rev 1	Emerson.com		
	Emerson	375/475: DD Rev 2	475 Field Communicator		
1	All	DD4: DD Rev 4	FieldComm Group	Emerson.com	00809-0200-41 01, Rev BA
	All	DD5: NA	N/A		
	Emerson	AMS Device Manager V 8 or higher: DD Rev 2	Emerson.com		

Table 2-1: Rosemount 2051 FOUNDATION™ Fieldbus device revisions and files (continued)

Device revision (1)	Host	Device driver (DD) ⁽²⁾	Obtain at	Device driver (DTM)	Reference document
	Emerson	375/475: DD Rev 2	475 Field Communicator		

- (1) FOUNDATIONFieldbus® device revision can be read using a FOUNDATION Fieldbus capable configuration tool.
- (2) Device driver file names use device and DD revision. To access functionality, the correct device driver must be installed on your control and asset management hosts and on your configuration tools.

Figure 2-1: Installation flowchart

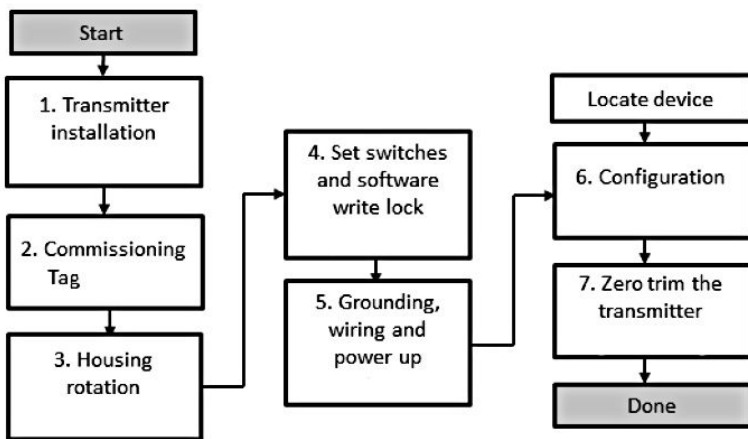

3 Mount the transmitter

3.1 Liquid applications

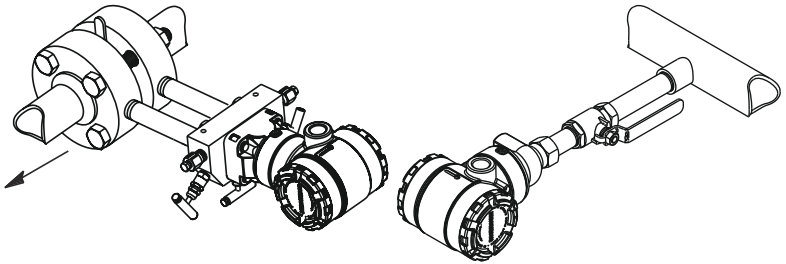

Procedure

1. Place taps to the side of the line.
2. Mount beside or below the taps.
3. Mount the transmitter so the drain/vent valves are oriented upward.

3.2 Gas applications

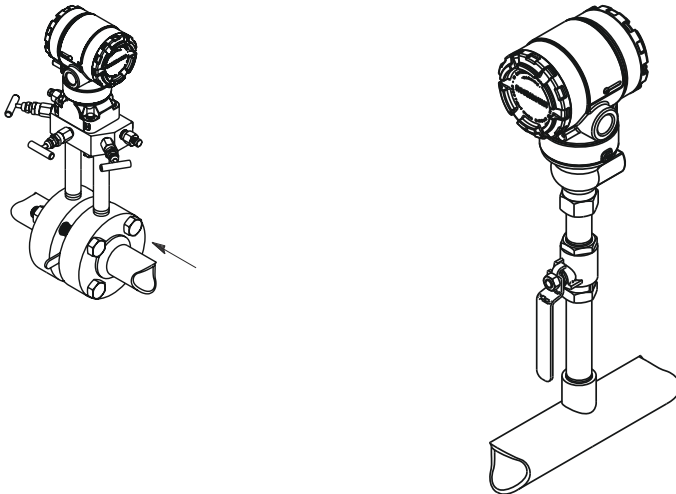

Procedure

1. Place taps on the top or side of the line.
2. Mount beside or above the taps.

3.3 Steam applications

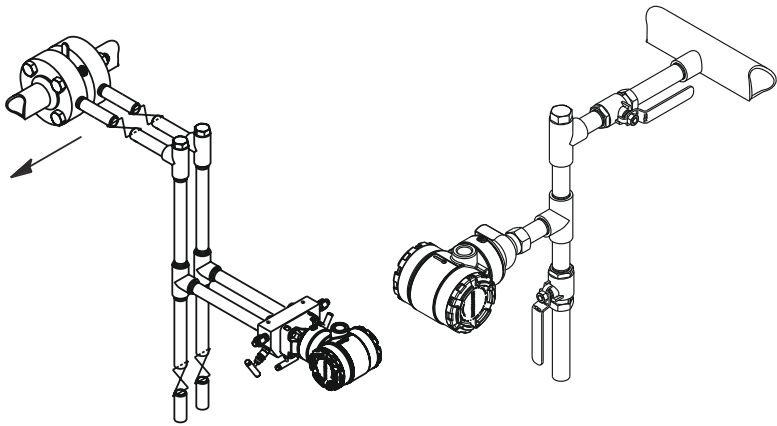

Procedure

1. Place taps to the side of the line.
2. Mount beside or below the taps.
3. Fill impulse lines with water.

3.4 Panel and pipe mounting

Figure 3-1: Panel and pipe mounting

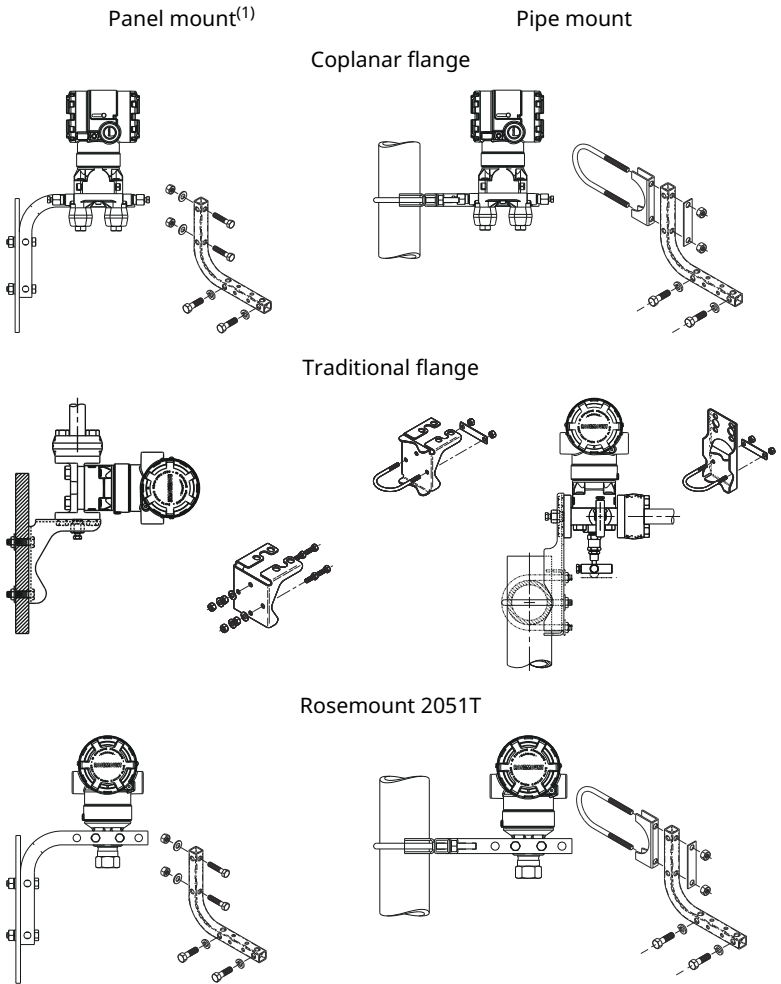

(1) 5/16 × 1½ panel bolts are customer supplied.

3.5 Install bolts

If the transmitter installation requires assembly of the process flanges, manifolds, or flange adapters, follow the assembly guidelines to ensure a tight seal for optimal performance

characteristics of the transmitters. Use only bolts supplied with the transmitter or sold by Emerson as spare parts. [Figure 3-2](#) illustrates common transmitter assemblies with the bolt length required for proper transmitter assembly.

Figure 3-2: Common transmitter assemblies

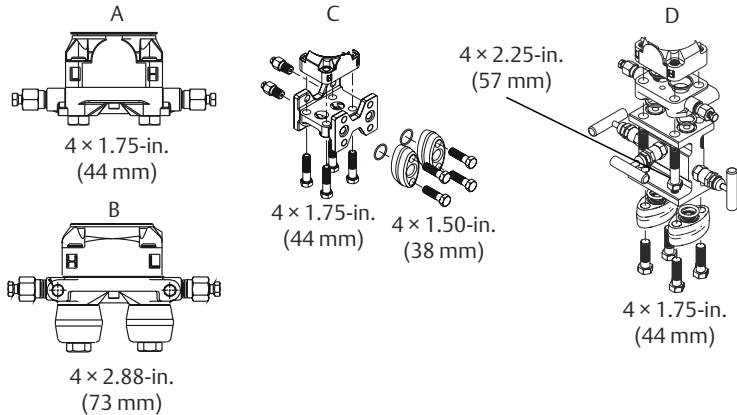

- A. *Transmitter with coplanar flange*
 B. *Transmitter with coplanar flange and optional flange adapters*
 C. *Transmitter with traditional flange and optional flange adapters*
 D. *Transmitter with coplanar flange and optional manifold and flange adapters*

Bolts are typically carbon steel (CS) or stainless steel (SST). Confirm the material by viewing the markings on the head of the bolt and referencing [Table 3-1](#). If bolt material is not shown in [Table 3-1](#), contact a local Emerson representative for more information.

Carbon steel bolts do not require lubrication, and the stainless steel bolts are coated with a lubricant to ease installation. However, do not apply any additional lubricant when installing either type of bolt.

Procedure

1. Tighten the bolts by hand.
2. Torque the bolts to the initial torque value using a crossing pattern.
See [Table 3-1](#) for initial torque value.
3. Torque the bolts to the final torque value using the same crossing pattern.
See [Table 3-1](#) for final torque value.

- Verify the flange bolts are protruding through the sensor module bolt holes before applying pressure.

Table 3-1: Torque values for the flange and flange adapter bolts

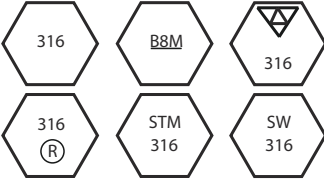
Bolt material	Head markings	Initial torque	Final torque
CS		300 in.-lb.	650 in.-lb.
SST		150 in.-lb.	300 in.-lb.

3.6 O-rings

The two styles of Rosemount flange adapters (Rosemount 3051/2051/2024/3095) each require a unique O-ring (see [Figure 3-3](#)). Use only the O-ring designed for the corresponding flange adapter.

⚠ WARNING

Failure to install proper flange adapter O-rings may cause process leaks, which can result in death or serious injury.

The two flange adapters are distinguished by unique O-ring grooves. Only use the O-ring that is designed for its specific flange adapter, as shown in [Figure 3-3](#). When compressed, PTFE O-rings tend to cold flow, which aids in their sealing capabilities.

Figure 3-3: O-rings

ROSEMOUNT 3051S/3051/2051/3001/3095/2024

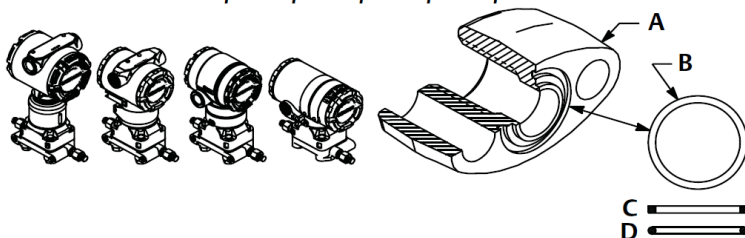

- A. Flange adapter
- B. O-ring
- C. PFTE based
- D. Elastomer

NOTICE

Replace PTFE O-rings if you remove the flange adapter.

3.7 Environmental seal for housing

Thread sealing (PTFE) tape or paste on male threads of conduit is required to provide a water/dust tight conduit seal and meets requirements of NEMA® Type 4X, IP66, and IP68. Consult factory if other Ingress Protection ratings are required.

For M20 threads, install conduit plugs to full thread engagement or until mechanical resistance is met.

3.8 In-line gauge transmitter orientation

The low side pressure port (atmospheric reference) on the in-line gauge transmitter is located in the neck of the transmitter, behind the housing. The vent path is 360° around the transmitter between the housing and sensor. (See [Figure 3-4.](#))

Keep the vent path free of any obstruction, including but not limited to paint, dust, and lubrication by mounting the transmitter so fluids can drain away.

Figure 3-4: In-line gauge low side pressure port

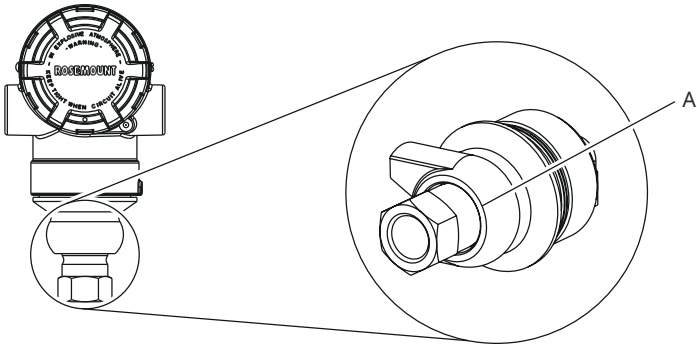

A. Pressure port location

4 Tagging

4.1 Commissioning (paper) tag

To identify which device is at a particular location use the removable tag provided with the transmitter. Ensure the physical device tag (PD tag field) is properly entered in both places on the removable commissioning tag and tear off the bottom portion for each transmitter.

Figure 4-1: Commissioning tag

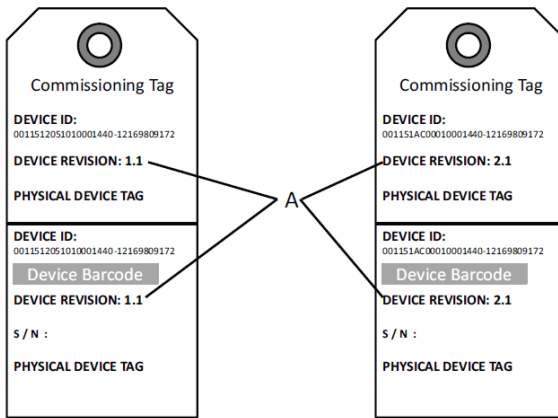

A. Device revision

Note

The device description loaded in the host system must be at the same revision as this device. You can download the device description from the host system website or [Emerson.com/Rosemount](https://www.emerson.com) by selecting **Download Device Drivers** under *Product Quick Links*. You can also visit [FieldComm Group](https://www.emerson.com) and select **Resources**.

5 Rotate housing

To improve field access to wiring or to better view the optional LCD display:

Procedure

1. Loosen the housing rotation set screw using a 5/64 -in. hex wrench.

Figure 5-1: Housing rotation

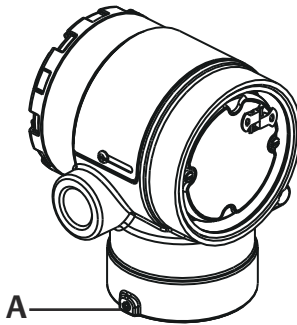

A. Housing rotation set screw (5/64-in.)

2. Rotate the housing clockwise to the desired location.
3. If the desired location cannot be achieved due to thread limitation, rotate the housing counterclockwise to the desired location (up to 360° from thread limit).
4. Retighten the housing rotation set screw to no more than 7 in.-lbs. when desired location is reached.

6 Set the switches

Set simulate and security switch configuration before installation as shown in [Figure 6-1](#).

- The simulate switch enables or disables simulated alerts and simulated AI Block status and values. The default simulate switch position is enabled.
- The security switch allows (unlocked symbol) or prevents (locked symbol) any configuration of the transmitter.
- Default security is off (unlocked symbol).
- You can enable or disable the security switch in the software.

Use the following procedure to change the switch configuration:

Procedure

1. If the transmitter is installed, secure the loop, and remove power.
2. Remove the housing cover opposite the field terminal side.

⚠ WARNING

Do not remove the instrument cover in explosive atmospheres when the circuit is live.

3. Slide the security and simulate switches into the preferred position.
4. Replace the housing cover.

NOTICE

Emerson recommends tightening the cover until there is no gap between the cover and housing.

Figure 6-1: Simulate and security switches

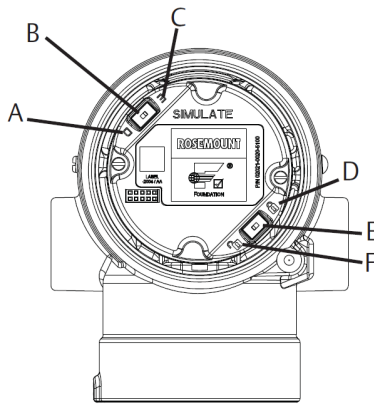

- A. *Simulate disabled position*
- B. *Simulate switch*
- C. *Simulate enabled position (default)*
- D. *Security locked position*
- E. *Security switch*
- F. *Security unlocked position (default)*

7 Wire, ground, and power up

Prerequisites

Use copper wire of sufficient size to ensure that the voltage across the transmitter power terminals does not drop below 9 Vdc. Power supply voltage can be variable, especially under abnormal conditions, such as when operating on battery backup. Emerson recommends using a minimum of 12 Vdc under normal operating conditions and using shielded twisted pair Type A cable.

Procedure

1. To power the transmitter, connect the power leads to the terminals indicated on the terminal block label.

Figure 7-1: Wiring terminals

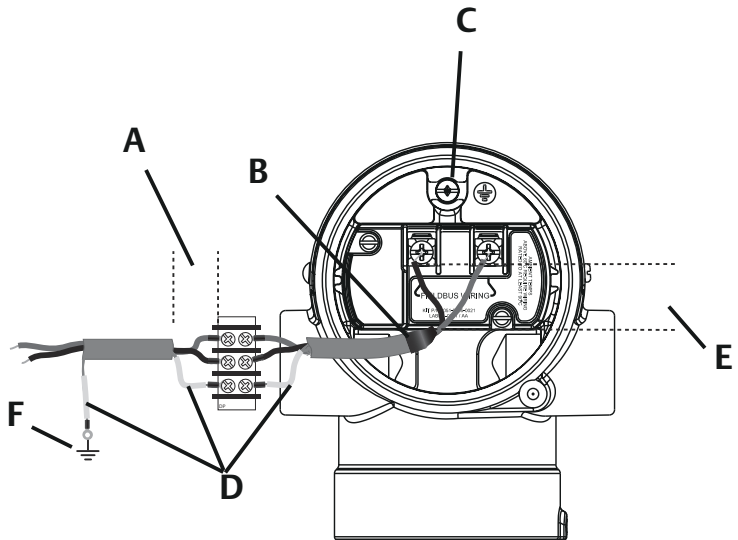

- A. Minimize distance
- B. Trim shield and insulate
- C. Protective grounding terminal (do not ground cable shield at the transmitter)
- D. Insulate shield
- E. Minimize distance
- F. Connect shield back to the power supply ground

NOTICE

The Rosemount 2051 power terminals are polarity insensitive, which means the electrical polarity of the power leads does not matter when connecting to the power terminals. If polarity sensitive devices are connected to the segment, follow terminal polarity. When wiring to the screw terminals, Emerson recommends using crimped legs.

2. Ensure full contact with terminal block screw and washer. When using a direct wiring method, wrap wire clockwise to ensure it is in place when tightening the terminal block screw. No additional power is needed.

NOTICE

Emerson does not recommend using a pin or ferrule wire, as the connection may be more susceptible to loosening over time or under vibration.

7.1 Power supply

The transmitter requires between 9 and 32 Vdc (9 and 30 Vdc for intrinsic safety, and 9 and 17.5 Vdc for FISCO intrinsic safety) to operate and provide complete functionality.

7.2 Power conditioner

A Fieldbus segment requires a power conditioner to isolate the power supply, filter, and decouple the segment from other segments attached to the same power supply.

7.3 Grounding

NOTICE

Do not ground the Fieldbus segment's signal wiring. Grounding out one of the signal wires will shut down the entire Fieldbus segment.

7.4 Ground shield wire

NOTICE

To protect the Fieldbus segment from noise, grounding techniques for shield wire require a single grounding point for shield wire to avoid creating a ground loop.

Connect the cable shields for the entire segment to a single good earth ground at the power supply.

7.5 Signal termination

Install a terminator at the beginning and at the end of every Fieldbus segment.

7.6 Locate devices

Devices are frequently installed, configured, and commissioned over time by different personnel. Emerson provides a **Locate Device** capability to assist personnel in finding a device.

From the device **Overview** screen, select **Locate Device**. This will launch a method allowing you to display a `Find me` message or enter a custom message to display on the device LCD display.

When you exit the **Locate Device** method, the device LCD display automatically returns to normal operation.

Note

Some hosts do not support **Locate Device** in the device driver (DD).

8 Configuration

Each FOUNDATION™ Fieldbus host or configuration tool has a different way of displaying and performing configurations.

Some use device descriptions (DD) or DD methods for configuration and to display data consistently across platforms. There is no requirement that a host or configuration tool support these features. Use the following block examples to do basic configuration to the transmitter. For more advanced configurations, see the [Rosemount 2051 Reference Manual](#).

Note

DeltaV™ users should use DeltaV Explorer for the resource and transducer blocks and Control Studio for the function blocks.

8.1 AI block configuration

If your configuration tool supports Dashboard device descriptions (DDs) or DTMs, you may use either guided setup or manual setup. If your configuration tools don't support Dashboard DDs or DTMs, use manual setup.

Navigation instructions for each step are provided below. In addition the screens used for each step are shown in [Figure 2-1](#).

Figure 8-1: Configuration flowchart

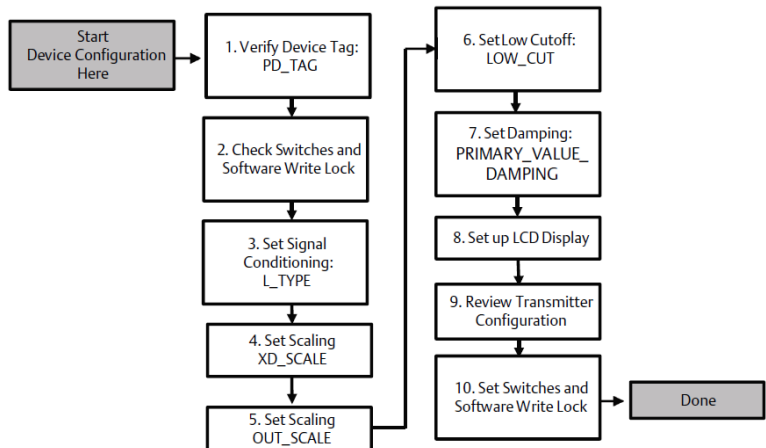
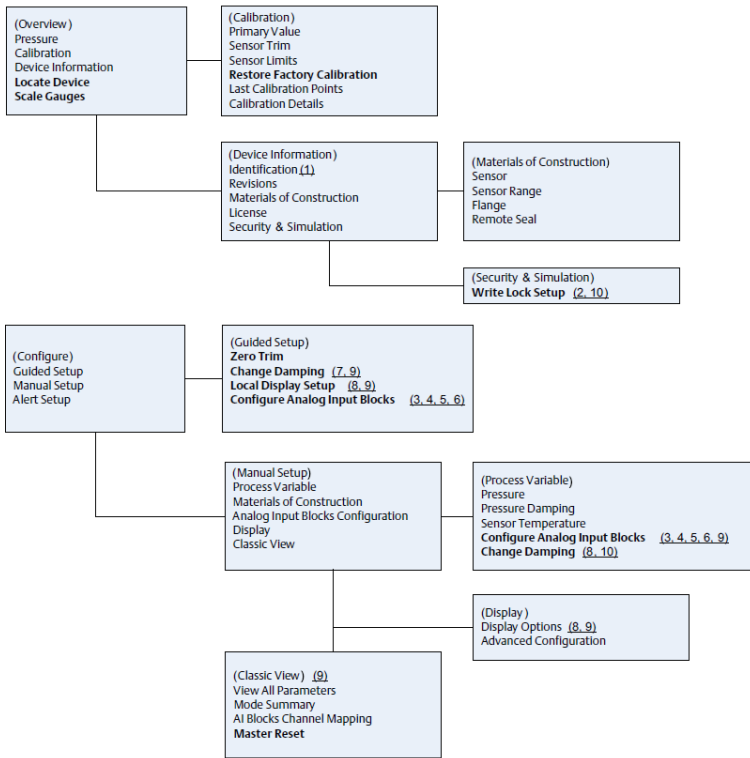

Figure 8-2: Basic configuration menu tree



Standard text Navigation selections available

(Text) Name of selection used on parent menu tree to access this screen

Bold text Automated methods

Underlined text Configuration task numbers from configuration flowchart

8.2 Prepare for configuration

See [Figure 8-1](#) to view the step-by-step process for basic device configuration.

Before beginning configuration, you may need to verify the Device Tag or deactivate hardware or software write protection on the transmitter. To do this, see the following procedure. Otherwise, continue to [Configure the AI block](#).

Procedure

1. To verify the device tag, go to **Overview** → **Device Information**.
2. To check the switches, verify the write lock switch is in the unlocked position if the switch has been enabled in software. See [Figure 6-1](#).
3. To disable the software write lock:
 - a) From the **Overview** screen, go to **Device Information** → **Security and Simulation**.
 - b) Perform `Write Lock Setup` to disable software write lock.
 - c) Place the control loop in Manual mode .

Postrequisites

Continue to [Configure the AI block](#).

8.3 Configure the AI block

Procedure

1. To use guided setup:
 - a) Navigate to **Configure** → **Guided Setup**.
 - b) Select **AI Block Unit Setup**.

Note

Guided setup will automatically go through each step in the proper order.

Note

For convenience, AI Block 1 is pre-linked to the transmitter primary variable and should be used for this purpose. AI Block 2 is pre-linked to the transmitter sensor temperature.

- Channel 1 is the primary variable.
 - Channel 2 is the sensor temperature.
-

Note

[Step 3](#) through [Step 6](#) are all performed in a single step-by-step method under guided setup or on a single screen using manual setup.

Note

If the **L_TYPE** selected in [Step 2](#) is **Direct**, [Step 3](#), [Step 4](#), and [Step 5](#) are not needed. If guided setup is used, any unneeded steps will automatically be skipped.

2. To select the signal conditioning **L_TYPE** from the drop-down menu:
 - Select **Direct** for pressure measurements using the device default units.
 - Select **Indirect** for other pressure or level units.
 - Select **Indirect Square Root** for flow units.
3. To set **XD_SCALE** to the 0% and 100% scale points (the transmitter range):
 - a) Select the **XD_SCALE_UNITS** from the drop-down list.
 - b) Enter the **XD_SCALE 0%** point.

This may be elevated or suppressed for level applications.
 - c) Enter the **XD_SCALE 100%** point.

This may be elevated or suppressed for level applications.

If **L_TYPE** is **Direct**, the AI Block may be placed in mode to return the device to service. Guided setup does this automatically.

4. If **L_TYPE** is **Indirect** or **Indirect Square Root**, set **OUT_SCALE** to change engineering units.
 - a) Select the **OUT_SCALE UNITS** from the drop-down list.
 - b) Set the **OUT_SCALE** low value.

This may be elevated or suppressed for level applications.
 - c) Set the **OUT_SCALE** high value.

This may be elevated or suppressed for level applications.

If **L_TYPE** is **Indirect**, the AI Block may be placed in **AUTO** mode to return the device to service. Guided setup does this automatically.

5. Change damping.
 - To use guided setup:
 - a. Navigate to **Configure** → **Guided Setup** and select **Change Damping**.

Note
Guided setup will automatically go through each step in the proper order.

 - b. Enter the desired damping value in seconds. The permitted range of values is 0.4 to 60 seconds.
 - To use manual setup:
 - a. Navigate to **Configure** → **Manual Setup** → **Process Variable** and select **Change Damping**.
 - b. Enter the desired damping value in seconds. The permitted range of values is 0.4 to 60 seconds.

6. Configure LCD display (if installed).
 - To use guided setup:
 - a. Navigate to **Configure** → **Guided Setup** and select **Local Display Setup**.

Note
Guided setup will automatically go through each step in the proper order.

 - b. Check the box next to each parameter to be displayed to a maximum of four parameters. The LCD display will continuously scroll through the selected parameters.
 - To use manual setup:
 - a. Navigate to **Configure** → **Manual Setup** and select **Local Display Setup**.
 - b. Check each parameter to be displayed. The LCD display will continuously scroll through the selected parameters.

7. Review transmitter configuration and place in service.
 - a) To review the transmitter configuration, navigate using the guided setup navigation sequences for AI Block Unit Setup, Change Damping, and Set up LCD Display.
 - b) Change any values as necessary.
 - c) Return to the **Overview** screen.

- d) If Mode is Not in Service, select the **Change** button and then select **Return All to Service**.

Note

If hardware or software write protection is not needed, [Step 8](#) can be skipped.

8. Set switches and software write lock. Check switches.
See [Figure 6-1](#).

Note

The write lock switch can be left in the locked or unlocked position. The simulate enable/disable switch may be in either position for normal device operation.

8.4 Enable software write lock

Procedure

1. From the **Overview** screen, select **Device Information**.
2. Select the **Security and Simulation** tab.
3. Perform `Write Lock Setup` to enable software write lock.

8.5 AI block configuration parameters

Use [Table 8-1](#), [Table 8-2](#), and [Table 8-3](#) for guides.

Parameters	Enter data				
Channel	1 Pressure 2 Sensor Temp				
L-Type	Direct, Indirect, or Square Root				
XD_Scale	Scale and Engineering Units				
Note Select only the units that are supported by the device.	Pa	bar	torr at 0 °C	ftH ₂ O at 4 °C	mH ₂ O at 4 °C
	kPa	mbar	kg/cm ²	ftH ₂ O at 60 °F	mmHg at 0 °C
	mPa	psf	kg/m ²	ftH ₂ O at 68 °F	cmHg at 0 °C
	hPa	Atm	inH ₂ O at 4 °C	mH ₂ O at 4 °C	inHg at 0 °C
	°C	psi	inH ₂ O at 60 °F	mmH ₂ O at 68 °C	mHg at 0 °C
	°F	g/cm ²	inH ₂ O at 68 °F	cmH ₂ O at 4 °C	

Parameters	Enter data
Out_Scale	Scale and Engineering Units

Table 8-1: Pressure example

Parameters	Enter data
Channel	1
L_Type	Direct
XD_Scale	See list of supported engineering units.
Note Select only the units that are supported by the device.	
Out_Scale	Set values outside operating range.

Table 8-2: DP Flow example

Parameters	Enter data
Channel	1
L_Type	Square Root
XD_Scale	0–100 inH ₂ O at 68 °F
Note Select only the units that are supported by the device.	
Out_Scale	0–20 GPM
Low_Flow_Cutoff	inH ₂ O at 68 °F

Table 8-3: DP Level example

Parameters	Enter data
Channel	1
L_Type	Indirect
XD_Scale	0–300 inH ₂ O at 68 °F
Note Select only the units that are supported by the device.	
Out_Scale	0–25 ft.

8.6 Display pressure on the LCD display meter

Select the Pressure check box on the **Display Configuration** screen.

9 Zero trim the transmitter

Note

Emerson ships transmitters fully calibrated per request or by the factory default of full scale (span = upper range limit).

A zero trim is a single-point adjustment used for compensating mounting position and line pressure effects. When performing a zero trim, ensure the equalizing valve is open and all wet legs are filled to the correct level.

The transmitter will only allow three to five percent upper range limit (URL) zero error to be trimmed. For greater zero errors, compensate for the offset by using the XD_Scaling, Out_Scaling and Indirect L_Type, which are part of the AI block.

Procedure

Zero trim the transmitter.

- To use guided setup, navigate to **Configure** → **Guided Setup** and select **Zero Trim**. The method will execute the zero trim.
- To use manual setup, navigate to **Overview** → **Calibration** → **Sensor Trim** and select **Zero Trim**. The method will execute the zero trim.

10 Rosemount 2051 product certifications

Rev 1.28

10.1 European Directive information

A copy of the EU Declaration of Conformity can be found at the end of the Quick Start Guide. The most recent revision of the EU Declaration of Conformity can be found at [Emerson.com](https://www.emerson.com).

10.2 Ordinary location certification

As standard, the transmitter has been examined and tested to determine that the design meets the basic electrical, mechanical, and fire protection requirements by a Nationally Recognized Test Laboratory (NRTL) as accredited by the Federal Occupational Safety and Health Administration (OSHA).

10.3 Hazardous location certification

NOTICE

Device ambient temperature ratings and electrical parameters may be limited to the levels dictated by the hazardous location certificate parameters.

10.4 North America

E5 USA Explosionproof (XP) and Dust Ignition-proof (DIP)

Certificate	2041384
Standards	FM 3600: 2022, FM 3615: 2022, FM 3616: 2022, ANSI/UL 61010-1-2019 Third Edition, ANSI/UL 12.27.01: 2022 (Fourth Edition), ANSI/UL 50E (First Edition)
Markings	XP CL I, DIV I, GP B, C, & D T5; SEAL NOT REQUIRED DIP CL II, DIV I, GP E, F, & G; CL III T5; T5: (-50 °C ≤ Ta ≤ 85 °C) TYPE 4X, IP 68 OPTIONAL: SINGLE SEAL

Specific Conditions of Use:

1. The Model 2051 transmitter housing may contain aluminum and is considered a potential risk of ignition by impact or friction. Care must be taken during installation and use to prevent impact and friction.
2. Equipment evaluated for atmospheric pressure range between 80 kPa (0,8 bar) to 110 kPa (1,1 bar).
3. Process temperature limits shall be in accordance with 03031-1053.

IS USA Intrinsic Safety (IS), Nonincendive (NI)

Certificate	2041384
Standards	FM3600: 2022, FM3610: 2021, FM3611: 2021, ANSI/UL61010-1-2019 Third Edition, ANSI/UL60079-0: 2017, ANSI/UL60079-11: 2013, ANSI/UL12.27.01: 2022 (Fourth Edition), ANSI/UL50E (First Edition)
Markings	IS: CL I GP A, B, C, D T4; CL II GP EFG; CL III T4; CL I ZN 0 AEx ia IIC T4 Ga; NI: CL I DIV 2 GP ABCD T4; (-50 °C ≤ Ta ≤ +70 °C) OPTIONAL: SINGLE SEAL TYPE 4X, IP 68 INSTALL PER 02051-1008.

Specific Conditions of Use:

1. The Model 2051 transmitter housing may contain aluminum and is considered a potential risk of ignition by impact or friction. Care must be taken during installation and use to prevent impact and friction.
2. The Model 2051 with the transient terminal block (Option code T1) will not pass the 500 VRMS dielectric strength test; this must be considered during installation.
3. Equipment evaluated for atmospheric pressure range between 80 kPa (0,8 bar) to 110 kPa (1,1 bar).
4. Maximum process temperature limits shall be in accordance with 03031-1053.

IE USA FISCO

Certificate	2041384
--------------------	---------

Standards	FM 3600: 2022, FM 3610: 2021, FM 3611: 2021, ANSI/UL 61010-1-2019 Third Edition, ANSI/UL 60079-0: 2017, ANSI/UL 60079-11: 2013, ANSI/UL 12.27.01: 2022 (Fourth Edition), ANSI/UL 50E (First Edition)
Markings	IS: CL I GP ABCD T4 CL I ZN 0 AEx ia IIC T4 Ga -50 °C ≤ Ta ≤ +60 °C FISCO TYPE 4X, IP 68 INSTALL PER 02051-1008 OPTIONAL: SINGLE SEAL

Specific Conditions of Use:

1. The Model 2051 transmitter housing may contain aluminum and is considered a potential risk of ignition by impact or friction. Care must be taken during installation and use to prevent impact and friction.
2. Equipment evaluated for atmospheric pressure range between 80 kPa (0,8 bar) to 110 kPa (1,1 bar).
3. Process temperature limits shall be in accordance with 03031-1053.

E6 Canada Explosionproof, Dust Ignition-proof

Certificate	2041384
Standards	CAN/CSA C22.2 No. 61010-1-12, CAN/CSA C22.2 No. 94.2-07, CSA C22.2 No. 25-17, CAN/CSA C22.2 No. 30:20, CAN/CSA C22.2 No. 60079-0:19, CAN/CSA C22.2 No. 60079-1:16, ANSI/UL 12.27.01: 2022 (Fourth Edition)
Markings:	XP: CL I, DIV I, GP B,C, D T5; Ex db IIC T5 Gb; SEAL NOT REQUIRED DIP: CL II, DIV I, GP E, F, & G; CL III T5; -50 °C ≤ Ta ≤ 85 °C SINGLE SEAL - TEMP LIMITS PER 03031-1053 TYPE 4X, IP 68

Specific Conditions of Use:

1. The Model 2051 transmitter housing may contain aluminum and is considered a potential risk of ignition by impact or friction. Care must be taken during installation and use to prevent impact and friction.
2. Equipment evaluated for atmospheric pressure range between 80 kPa (0,8 bar) to 110 kPa (1,1 bar).

I6 Canada Intrinsic Safety (IS)

Certificate	2041384
Standards	C22.2 No. 61010-1-12, C22.2 No. 25-17, C22.2 No. 94.2-20 Third Edition, CSA Std C22.2 No. 213-17 + UPD 1 (2018) + UPD 2 (2019) + UPD 3 (2021), CAN/CSA-60079-0:19, CAN/CSA-60079-11:14, ANSI/UL 122701: 2022 (Fourth Edition), ANSI/UL 50E (First Edition)
Markings	IS: CL I GP S, B, C, D T4; CL II GP E, F, G, CL III T4; Ex ia IIC T4 Ga; NI: CL I DIV 2 GP A, B, C, D -50 °C ≤ Ta ≤ +70 °C INSTALL PER 02051-1008 SINGLE SEAL - TEMP LIMITS PER 03031-1053 TYPE 4X, IP 68

Specific Conditions of Use:

1. The Model 2051 transmitter housing may contain aluminum and is considered a potential risk of ignition by impact or friction. Care must be taken during installation and use to prevent impact and friction.
2. The Model 2051 with the transient terminal block (Option code T1) will not pass the 500 VRMS dielectric strength test; this must be considered during installation.
3. Equipment evaluated for atmospheric pressure range between 80 kPa (0,8 bar) to 110 kPa (1,1 bar).

IF Canada FISCO

Certificate	2041384
Standards	C22.2 No. 61010-1-12, C22.2 No. 25-17, C22.2 No. 94.2-20 Third Edition, CSA Std C22.2 No. 213-17 +

UPD 1 (2018) + UPD 2 (2019) + UPD 3 (2021), CAN/CSA-60079-0:19, CAN/CSA-60079-11:14, ANSI/UL 12.27.01:2022 (Fourth Edition), ANSI/UL 50E (First Edition)

Markings: IS: CL I GP ABCD T4;
 Ex ia IIC T4 Ga
 $-50\text{ °C} \leq T_a \leq +60\text{ °C}$
 FISCO
 INSTALL PER 02051-1008
 SINGLE SEAL - TEMP LIMITS PER 03031-1053
 TYPE 4X, IP 68

Specific Conditions of Use:

1. The Model 2051 transmitter housing may contain aluminum and is considered a potential risk of ignition by impact or friction. Care must be taken during installation and use to prevent impact and friction.
2. Equipment evaluated for atmospheric pressure range between 80 kPa (0,8 bar) to 110 kPa (1,1 bar).

10.5 Europe

E1 ATEX/UKEX Flameproof

ATEX Certificate KEMA 08ATEX0090X

UKEX Certificate DEKRA 21UKEX0288X

Standards EN IEC 60079-0: 2018, EN 60079-1: 2014, EN 60079-26: 2015

Markings:  II 1/2 G Ex db IIC Ga/Gb T6 ($-60\text{ °C} \leq T_a \leq +70\text{ °C}$), T4/T5 ($-60\text{ °C} \leq T_a \leq +80\text{ °C}$)

Table 10-1: Process connection temperature

Temperature class	Process connection temperature	Ambient temperature
T6	-60 °C to $+70\text{ °C}$	-60 °C to $+70\text{ °C}$
T5	-60 °C to $+80\text{ °C}$	-60 °C to $+80\text{ °C}$
T4	-60 °C to $+120\text{ °C}$	-60 °C to $+80\text{ °C}$

Special Conditions for Safe Use (X):

1. Appropriate cable, glands, and plugs need to be suitable for a temperature of 5 °C greater than maximum specified temperature for location where installed.
2. Non-standard paint options may cause risk from electrostatic discharge. Avoid installations that could cause electrostatic build-up on painted surfaces and only clean the painted surfaces with a damp cloth. If paint is ordered through a special option code, contact the manufacturer for more information.
3. This device contains a thin wall diaphragm less than 1 mm thick that forms a boundary between Category 1G (process connection) and Category 2G (all other parts of the equipment). The model code and datasheet are to be consulted for details of the diaphragm material. During installation, maintenance, and use, the environmental conditions to which the diaphragm will be subjected shall be taken into account. The manufacturer's instructions for installation and maintenance shall be followed in detail to assure safety during its expected lifetime.
4. Flameproof joints are not intended for repair.

Conduit/cable entries

Unless otherwise marked, the conduit/cable entries in the housing enclosure use a ½-14 NPT form. Only use plugs, adapters, glands, or conduit with a compatible thread form when closing these entries. Entries marked M20 are M20 x 1.5 thread form. On devices with multiple conduit entries, all entries will have the same thread form. When installing in a hazardous location, use only appropriately listed or Ex certified plugs, glands, or adapters in cable/conduit entries.

I1 ATEX Intrinsic Safety

Certificate	Baseefa08ATEX0129X
Standards	EN IEC 60079-0: 2018, EN60079-11: 2012
Markings	Ⓔ II 1 G Ex ia IIC T4 Ga (-60 °C ≤ Ta ≤ +70 °C)

Table 10-2: Input parameters

	HART®	Fieldbus/PROFIBUS®
Voltage U_i	30 V	30 V
Current I_i	200 mA	300 mA
Power P_i	1 W	1.3 W
Capacitance C_i	0.012 μ F	0 μ F
Inductance L_i	0 mH	0 mH

Special Conditions for Safe Use (X):

1. If the equipment is fitted with an optional 90 V transient suppressor, it is incapable of withstanding the 500 V isolation from earth test, and this must be taken into account during installation.
2. The enclosure may be made of aluminum alloy and given a protective polyurethane paint finish; however, care should be taken to protect it from impact or abrasion if located in Zone 0.

IA ATEX FISCO

Certificate	Baseefa08ATEX0129X
Standards	EN IEC 60079-0: 2018, EN60079-11: 2012
Markings	Ⓔ II 1 G Ex ia IIC T4 Ga (-60 °C ≤ Ta ≤ +60 °C)

Table 10-3: Input parameters

	FISCO
Voltage U_i	17.5 V
Current I_i	380 mA
Power P_i	5.32 W
Capacitance C_i	0 μ F
Inductance L_i	0 mH

Special Conditions for Safe Use (X):

1. If the equipment is fitted with an optional 90 V transient suppressor, it is incapable of withstanding the 500 V isolation from earth test, and this must be taken into account during installation.

- The enclosure may be made of aluminum alloy and given a protective polyurethane paint finish; however, care should be taken to protect it from impact or abrasion if located in Zone 0.

N1 ATEX Type n

Certificate	Baseefa08ATEX0130X
Standards	EN IEC 60079-0: 2018, EN60079-15: 2010
Markings	⊕ II 3 G Ex nA IIC T4 Gc (-40 °C ≤ Ta ≤ +70 °C)

Special Conditions for Safe Use (X):

- If the equipment is fitted with an optional 90 V transient suppressor, it is incapable of withstanding the 500 V electrical strength test as defined in clause 6.5.1 of by EN 60079-15: 2010. This must be taken into account during installation.

ND ATEX Dust

Certificate	Baseefa08ATEX0182X
Standards	EN IEC 60079-0: 2018, EN60079-31: 2014
Markings	⊕ II 1 D Ex ta IIIC T ₅₀₀ 105 °C Da (-20 °C ≤ Ta ≤ +85 °C)

Special Conditions for Safe Use (X):

- If the equipment is fitted with an optional 90 V transient suppressor, it is incapable of withstanding the 500 V isolation from earth test, and this must be taken into account during installation.
- Variants with a paint finish must not be installed in a dust-laden airflow.
- Non-standard paint options may cause risk from electrostatic discharge. Avoid installations that could cause electrostatic build-up on painted surfaces and only clean the painted surfaces with a damp cloth. If paint is ordered through a special option code, contact the manufacturer for more information.

10.6 International

E7 IECEx Flameproof

Certificate	IECExKEM08.0024X
--------------------	------------------

Standards	IEC 60079-0: 2017, IEC 60079-1: 2014-06, IEC 60079-26: 2014-10
Markings	Ex db IIC T6...T4 Ga/Gb T6 ($-60\text{ °C} \leq T_a \leq +70\text{ °C}$), T4/T5 ($-60\text{ °C} \leq T_a \leq +80\text{ °C}$)

Table 10-4: Process connection temperature

Temperature class	Process connection temperature	Ambient temperature
T6	-60 °C to $+70\text{ °C}$	-60 °C to $+70\text{ °C}$
T5	-60 °C to $+80\text{ °C}$	-60 °C to $+80\text{ °C}$
T4	-60 °C to $+120\text{ °C}$	-60 °C to $+80\text{ °C}$

Special Conditions for Safe Use (X):

1. This device contains a thin wall diaphragm less than 1 mm thick that forms a boundary between EPL Ga (process connection) and EPL Gb (all other parts of the equipment). The model code and datasheet are to be consulted for details of the diaphragm material. During installation, maintenance, and use, the environmental conditions to which the diaphragm will be subjected shall be taken into account. The manufacturer's instructions for installation and maintenance shall be followed in detail to assure safety during its expected lifetime.
2. Appropriate cable, glands, and plugs need to be suitable for a temperature of 5 °C greater than maximum specified temperature for location where installed.
3. Flameproof joints are not intended for repair.
4. Non-standard paint options may cause risk from electrostatic discharge. Avoid installations that could cause electrostatic build-up on painted surfaces and only clean the painted surfaces with a damp cloth. If paint is ordered through a special option code, contact the manufacturer for more information.

Conduit/cable entries

Unless otherwise marked, the conduit/cable entries in the housing enclosure use a ½-14 NPT form. Only use plugs, adapters, glands, or conduit with a compatible thread form when closing these entries. Entries marked M20 are M20 x 1.5 thread form. On devices with multiple conduit entries, all entries will have the same thread form. When installing in a hazardous location, use only appropriately listed or Ex certified plugs, glands, or adapters in cable/conduit entries.

I7 IECEx Intrinsic Safety

Certificate	IECEx BAS 08.0045X
Standards	IEC 60079-0: 2017, IEC 60079-11: 2011
Marking:	Ex ia IIC T4 Ga (-60 °C ≤ Ta ≤ +70 °C)

Table 10-5: Input parameters

	HART®	Fieldbus/PROFIBUS®
Voltage U_i	30 V	30 V
Current I_i	200 mA	300 mA
Power P_i	1 W	1.3 W
Capacitance C_i	12 nF	0 μF
Inductance L_i	0 mH	0 mH

Special Conditions for Safe Use (X):

1. If the equipment is fitted with an optional 90 V transient suppressor, it is incapable of withstanding the 500 V isolation from earth test, and this must be taken into account during installation.
2. The enclosure may be made of aluminum alloy and given a protective polyurethane paint finish; however, care should be taken to protect it from impact or abrasion if located in Zone 0.
3. The equipment contains thin wall diaphragms. The installation, maintenance, and use shall take into account the environmental conditions to which the diaphragms will be subjected. The manufacturer's instructions for installation and maintenance shall be followed in detail to assure safety during its expected lifetime.

IG IECEx FISCO

Certificate	IECEx BAS 08.0045X
Standards	IEC 60079-0: 2017, IEC60079-11: 2011
Markings	Ex ia IIC T4 Ga (-60 °C ≤ Ta ≤ +60 °C)

Table 10-6: Input parameters

	FISCO
Voltage U_i	17.5 V
Current I_i	380 mA
Power P_i	5.32 W
Capacitance C_i	0 nF
Inductance L_i	0 μ H

Special Conditions for Safe Use (X):

1. If the equipment is fitted with an optional 90 V transient suppressor, it is incapable of withstanding the 500 V isolation from earth test, and this must be taken into account during installation.
2. The enclosure may be made of aluminum alloy and given a protective polyurethane paint finish; however, care should be taken to protect it from impact or abrasion if located in Zone 0.
3. The equipment contains thin wall diaphragms. The installation, maintenance, and use shall take into account the environmental conditions to which the diaphragms will be subjected. The manufacturer's instructions for installation and maintenance shall be followed in detail to assure safety during its expected lifetime.

N7 IECEx Type n

Certificate	IECEX BAS 08.0046X
Standards	IEC 60079-0: 2017, IEC60079-15: 2010
Markings	Ex nA IIC T4 Gc (-40 °C ≤ Ta ≤ +70 °C)

Special Conditions for Safe Use (X):

1. If fitted with a 90 V transient suppressor, the equipment is not capable of withstanding the 500 V electrical strength test as defined in clause 6.5.1 of IEC60079-15: 2010. This must be taken into account during installation.

10.7 Brazil**E2 Brazil Flameproof**

Certificate	UL-BR 14.0375X (Sorocaba, Sao Paulo, Brazil), UL-BR22.3806X (Shakopee, MN, USA)
--------------------	--

	UL-BR22.3807X (Singapore)
Standards	ABNT NBR IEC 60079-0, ABNT NBR IEC 60079-1, ABNT NBR IEC 60079-26
Markings:	Ex db IIC T6...T4 Ga/Gb IP66, T6 (-60 °C ≤ Ta ≤ +70 °C), T4/T5 (-60 °C ≤ Ta ≤ +80 °C)

Special Conditions for Safe Use (X):

1. This device contains a thin wall diaphragm with less than 1 mm thickness that forms a boundary between zone 0 (process connection) and zone 1 (all other parts of the equipment). The model code and datasheet are to be consulted for details of the diaphragm material. Installation, maintenance, and use shall take into account the environmental conditions to which the diaphragm will be subjected. The manufacturer's instructions for installation and maintenance shall be followed in detail to assure safety during its expected lifetime.
2. Flameproof joints are not intended for repair.
3. Non-standard paint options may cause risk from electrostatic discharge. Avoid installations that could cause electrostatic build-up on painted surfaces and only clean the painted surfaces with a damp cloth. If paint is ordered through a special option code, contact the manufacturer for more information.

I2 Brazil Intrinsic Safety

Certificate	UL-BR 14.0759X
Standards	ABNT NBR IEC 60079-0: 2013; ABNT NBR IEC 60079-11: 2013
Markings	Ex ia IIC T4 Ga (-60 °C ≤ Ta ≤ +70 °C)

Table 10-7: Input parameters

	HART®	Fieldbus/PROFIBUS®
Voltage U_i	30 V	30 V
Current I_i	200 mA	300 mA
Power P_i	1 W	1.3 W
Capacitance C_i	12 nF	0
Inductance L_i	0	0

Special Conditions for Safe Use (X):

1. If the equipment is fitted with an optional 90 V transient suppressor, it is incapable of withstanding the 500 V insulation from earth test, and this must be taken into account during installation.
2. The enclosure may be made of aluminum alloy and given a protective polyurethane finish; however, care should be taken to protect it from impact and abrasion when located in atmospheres that require EPL Ga.

IB Brazil FISCO

Certificate	UL-BR 14.0759X
Standards	ABNT NBR IEC 60079-0: 2008 + Errata 1: 2011; ABNT NBR IEC 60079-11: 2009
Markings	Ex ia IIC T4 Ga (-60 °C ≤ Ta ≤ +60 °C)

Table 10-8: Input parameters

	FISCO
Voltage U_i	17.5 V
Current I_i	380 mA
Power P_i	5.32 W
Capacitance C_i	0 nF
Inductance L_i	0 μ H

Special Conditions for Safe Use (X):

1. If the equipment is fitted with an optional 90 V transient suppressor, it is incapable of withstanding the 500 V insulation from earth test, and this must be taken into account during installation.
2. The enclosure may be made of aluminum alloy and given a protective polyurethane finish; however, care should be taken to protect it from impact and abrasion when located in atmospheres that require EPL Ga.

10.8 China**E3 China Flameproof**

Certificate	GYJ18.1432X; GYJ20.1485X [Flow meters]
--------------------	--

Standards	GB3836.1-2010, GB3836.2-2010, GB3836.20-2010-2010
Markings	Pressure Transmitter: Ex d IIC Gb, T6~T4 Ga/Gb Flow meter: Ex d IIC T5/T6 Ga/Gb

I3 China Intrinsic Safety

Certificate	GYJ17.1225X22.1834X; GYJ20.1487X [Flow meters]
Standards	GB3/T 3836.1-2021, GB/T 3836.4-2021, GB3836.20-2010
Markings	Ex ia IIC T4 Ga, FISCO: Ex iaIICT4 Ga, Ex db+ibIICT4 Ga/Gb

10.9 Korea

EP Korea Flameproof

Certificate	12-KB4BO-0342X, 12-KB4BO-0344X, 19- KB4BO-0978X
Markings	Ex d IIC T6...T4 Ga/Gb, T4/T5 (-60 °C ≤ Ta ≤ +80 °C), T6 (-60 °C ≤ Ta ≤ +70 °C)

Special Conditions for Safe Use (X):

See certificate for special conditions.

IP Korea Intrinsic Safety

Certificate	12-KB4BO-0343X, 12-KB4BO-0345X, 13- KB4BO-0205X, 13-KB4BO-0207X, 18-KA4BO-0309X
Markings	Ex ia IIC T4 (-60 °C ≤ Ta ≤ +70 °C)

Special Conditions for Safe Use (X):

See certificate for special conditions.

10.10 Japan

E4 Japan Flameproof

Certificate	CML20JPN112X
Markings	Ex db IIC T6...T4 Ga/Gb, T6 (-60 °C ≤ Ta ≤ +70 °C), T5/T4 (-60 °C ≤ Ta ≤ +80 °C)

Special Conditions for Safe Use (X):

1. This device contains a thin wall diaphragm less than 1 mm thick that forms a boundary between EPL Ga (process connection) and EPL Gb (all other parts of the equipment). The model code and datasheet are to be consulted for details of the diaphragm material. During installation, maintenance, and use, the environmental conditions to which the diaphragm will be subjected shall be taken into account. The manufacturer's instructions for installation and maintenance shall be followed in detail to assure safety during its expected lifetime.
2. Flameproof joints are not intended for repair.
3. Non-standard paint options may cause risk from electrostatic discharge. Avoid installations that could cause electrostatic build-up on painted surfaces and only clean the painted surfaces with a damp cloth. If paint is ordered through a special option code, contact the manufacturer for more information.

10.11 EAC**EM EAC Flameproof**

Certificate	EAЭECKZRU7500525.01.01.00647
Markings	Ga/Gb Ex db IIC T4...T6 X, T4/T5 (-60 °C ≤ Ta ≤ +80 °C), T6 (-60 °C ≤ Ta ≤ +70 °C)

Special Conditions for Safe Use (X):

See certificate for special conditions.

IM EAC Intrinsically Safe

Certificate	EAЭEC KZRU7500525.01.01.00647
Markings	0Ex ia IIC T4 Ga X (-60 °C ≤ Ta ≤ +70 °C)

Special Conditions for Safe Use (X):

See certificate for special conditions.

10.12 Combinations

K1	Combination of E1, I1, N1, and ND
K2	Combination of E2 and I2
K5	Combination of E5 and I5
K6	Combination of E6 and I6

K7 Combination of E7, I7, N7, and IECEx Dust

IECEx Dust

Certificate IECEx BAS 08.0058X

Standards IEC60079-0: 2011, IEC60079-31: 2008

Markings Ex ta IIIC T95 °C T500105 °C Da (-20 °C ≤ Ta ≤ +85 °C)

Special Conditions for Safe Use (X):

1. If the equipment is fitted with an optional 90 V transient suppressor, it is incapable of withstanding a 500 V isolation from earth test, and this must be taken into account during installation.

KA Combination of E1, I1, and K6

KB Combination of K5 and K6



KC Combination of E1, I1, and K5

KD Combination of K1, K5, and K6

KP Combination of EP and IP

KM Combination of EM and IM

10.14 Declaration of Conformity

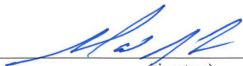
	<h2 style="margin: 0;">EU Declaration of Conformity</h2> <p style="margin: 0;">No: RMD 1071 Rev. U</p>	
<p>We,</p> <p style="margin-left: 40px;">Rosemount, Inc. 6021 Innovation Blvd. Shakopee, MN 55379 USA</p> <p>declare under our sole responsibility that the product,</p> <p style="text-align: center;">Rosemount™ Model 2051 Pressure Transmitter</p> <p>manufactured by,</p> <p style="margin-left: 40px;">Rosemount, Inc. 6021 Innovation Blvd. Shakopee, MN 55379 USA</p> <p>to which this declaration relates, is in conformity with the provisions of the European Union Directives, including the latest amendments, as shown in the attached schedule.</p> <p>Assumption of conformity is based on the application of the harmonized standards and, when applicable or required, a European Union notified body certification, as shown in the attached schedule.</p>		
 <hr/> <p>(signature)</p>	<p>Vice President of Global Quality (function)</p>	
<p>Mark Lee (name)</p>	<p><i>June 14, 2023</i> (date of issue & place)</p>	
<p>Page 1 of 3</p>		



EU Declaration of Conformity

No: RMD 1071 Rev. U



EMC Directive (2014/30/EU)

Harmonized Standards:

EN 61326-1:2013, EN 61326-2-3:2013

PED Directive (2014/68/EU)

Rosemount 2051CD2, 3, 4, 5 (also with P9 option)

QS Certificate of Assessment - Certificate No. 12698-2018-CE-ACCREDIA

Module H Conformity Assessment

Other Standards Used:

ANSI / ISA 61010-1:2004

All other Rosemount 2051 Pressure Transmitters

Sound Engineering Practice

Transmitter Attachments: Diaphragm Seal, Process Flange, or Manifold

Sound Engineering Practice

Rosemount 2051CFx DP Flowmeter

See DSI 1000 Declaration of Conformity

ATEX Directive (2014/34/EU)

Baseefa08ATEX0129X - Intrinsic Safety Certificate

Equipment Group II Category 1 G

Ex ia IIC T4 Ga

Equipment Group II Category 1/2 G

Ex db+ib/ib IIC T4 Ga/Gb

Harmonized Standards Used:

EN IEC 60079-0:2018, EN 60079-1:2014, EN 60079-11:2012,
EN 60079-26:2015

Baseefa08ATEX0130X - Type n Certificate

Equipment Group II Category 3 G

Ex nA IIC T4 Gc

Harmonized Standards Used:

EN IEC 60079-0:2018, EN 60079-15:2010

KEMA08ATEX0090X - Flameproof Certificate

Equipment Group II Category 1/2 G

Ex db IIC T6...T4 Ga/Gb

Harmonized Standards Used:

EN IEC 60079-0:2018, EN 60079-1:2014; EN 60079-26:2015



EU Declaration of Conformity



No: RMD 1071 Rev. U

Baseefa08ATEX0182X - Dust Certificate

Equipment Group II Category 1 D

Ex ta IIIC T₃₀₀105°C Da

Harmonized Standards Used:

EN IEC 60079-0:2018, EN 60079-31:2014

RoHS Directive (2011/65/EU)

Model 2051 with 4-20 mA HART protocol only (output code A)

Harmonized Standards:

EN 50581:2012

PED Notified Body

DNV GL Business Assurance Italia S.r.l. [Notified Body Number: 0496]

Via Energy Park, 14, N-20871

Vimercate (MB), Italy

ATEX Notified Bodies

DEKRA [Notified Body Number: 0344]

Utrechtseweg 310, 6812 AR Arnhem

P.O. Box 5185, 6802 ED Arnhem

The Netherlands

Postbank 6794687

SGS FIMKO OY [Notified Body Number: 0598]

Takomotie 8

FI-00380 Helsinki,

Finland

ATEX Notified Body for Quality Assurance

SGS FIMKO OY [Notified Body Number: 0598]

Takomotie 8

FI-00380 Helsinki,

Finland

10.15 China RoHS

有害物质成分表
03031-9021, Rev AB

罗斯蒙特产品型号 2051
3/29/2011

含有China RoHS管控物质超过最大浓度限值的部件型号列表 2051
List of 2051 Parts with China RoHS Concentration above MCVs

部件名称 Part Name	有害物质 / Hazardous Substances					
	铅 Lead (Pb)	汞 Mercury (Hg)	镉 Cadmium (Cd)	六价铬 Hexavalent Chromium (Cr +6)	多溴联苯 Polybrominated biphenyls (PBB)	多溴联苯醚 Polybrominated diphenyl ethers (PBDE)
电子组件 Electronics Assembly	X	○	○	○	○	○
壳体组件 Housing Assembly	○	○	○	○	○	○
传感器组件 Sensor Assembly	X	○	○	○	○	○

本表格系依据SJ/T11364的规定而制作。

This table is proposed in accordance with the provision of SJ/T11364.

○: 意为该部件的所有均质材料中该有害物质的含量均低于GB/T 26572所规定的限量要求。

O: Indicate that said hazardous substance in all of the homogeneous materials for this part is below the limit requirement of GB/T 26572.

X: 意为在该部件所使用的均质材料里, 至少有一类均质材料中该有害物质的含量高于GB/T 26572所规定的限量要求。

X: Indicate that said hazardous substance contained in at least one of the homogeneous materials used for this part is above the limit requirement of GB/T 26572.

部件名称 Part Name	组装备件说明 Spare Parts Descriptions for Assemblies
电子组件 Electronics Assembly	电子线路板组件 Electronic Board Assemblies 端子块组件 Terminal Block Assemblies 升级套件 Upgrade Kits 液晶显示屏或本地操作界面 LCD or LOI Display
壳体组件 Housing Assembly	电子外壳 Electrical Housing
传感器组件 Sensor Assembly	传感器模块 Sensor Module



Quick Start Guide
00825-0600-4101, Rev. DB
September 2023

For more information: [Emerson.com/global](https://www.emerson.com/global)

©2023 Emerson. All rights reserved.

Emerson Terms and Conditions of Sale are available upon request. The Emerson logo is a trademark and service mark of Emerson Electric Co. Rosemount is a mark of one of the Emerson family of companies. All other marks are the property of their respective owners.

ROSEMOUNT™

