

# Rosemount™ 3051S Series Pressure Transmitter and Rosemount 3051SF Series Flowmeter

with WirelessHART® Protocol



## Safety messages

### NOTICE

This guide provides basic guidelines for Rosemount™ 3051S and 3051S MultiVariable™ Wireless Transmitters. It does not provide instructions for diagnostics, maintenance, service, or troubleshooting. Refer to the Rosemount 3051S and 3051S MultiVariable Wireless [Reference Manual](#) for more instruction. This document is also available electronically on [Emerson.com/Rosemount](http://Emerson.com/Rosemount).

### ⚠ WARNING

Explosions could result in death or serious injury.

Installation of device in an explosive environment must be in accordance with appropriate local, national, and international standards, codes, and practices.

Review [Rosemount 3051S and 3051SMV Wireless Product Certifications](#) of this guide for any restrictions associated with a safe installation.

- Before connecting a handheld communicator in an explosive atmosphere, make sure the instruments in the loop are installed in accordance with intrinsically safe or non-incendive field wiring practices.

Electrical shock could cause death or serious injury.

- Avoid contact with the leads and terminals. High voltage that may be present on leads can cause electrical shock.

This device complies with Part 15 of the FCC Rules. Operation is subject to the following conditions:

- This device may not cause harmful interference.
- This device must accept any interference received, including interference that may cause undesired operation.
- This device must be installed to ensure a minimum antenna separation distance of 20 cm (8 in.) from all persons.

Power module considerations.

- The power module may be replaced in a hazardous area. The power module has surface resistivity greater than one gigaohm and must be properly installed in the wireless device enclosure. Care must be taken during transportation to and from the point of installation to prevent electrostatic charge build-up.

### ⚠ CAUTION

Shipping considerations for wireless products.

The unit was shipped to you without the power module installed. Remove the power module prior to shipping.

Each power module contains two "C" size primary lithium batteries. Primary lithium batteries are regulated in transportation by the U. S. Department of Transportation, and are also covered by IATA (International Air Transport Association), ICAO (International Civil Aviation Organization), and ARD (European Ground Transportation of Dangerous Goods). It is the responsibility of the shipper to ensure compliance with these or any other local requirements. Consult current regulations and requirements before shipping.

**Contents**

Wireless considerations.....	5	Verify operation.....	21
Mount the transmitter.....	7	Reference information.....	24
Connect the power module.....	18	Rosemount 3051S and 3051SMV Wireless	
Trim the transmitter.....	19	Product Certifications.....	25
Close the housing.....	20		



# 1 Wireless considerations

## 1.1 Power up sequence

The Wireless Gateway should be installed and functioning properly before any wireless field devices are powered. Install the Black Power Module, SmartPower™ Solutions model number 701PBKKF (part number 00753-9220-0001) into the Rosemount 702 Transmitter to power the device. Wireless devices should be powered up in order of proximity from the Gateway, beginning with the closest device, then working outward from the Gateway. This results in a simpler and faster network installation. Enable Active Advertising on the Gateway to ensure new devices are able to join the network faster. For more information see the Emerson™ Wireless 1420 Gateway [Reference Manual](#).

## 1.2 Antenna position

The antenna should be positioned vertically, either straight up or straight down, and it should be approximately 3 ft. (1 m) from any large structure, building, or conductive surface to allow for clear communication to other devices.

**Figure 1-1: Antenna Position**

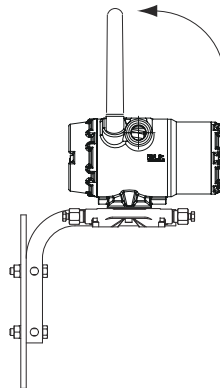

## 1.3 Conduit entry

Upon installation, ensure each conduit entry is either sealed with a conduit plug using approved thread sealant, or has an installed conduit fitting or cable gland with appropriate threaded sealant. Note the conduit entries on the Emerson 781 Field Link are threaded  $\frac{1}{2}$ -14 NPT.

**Figure 1-2: Conduit Entry**

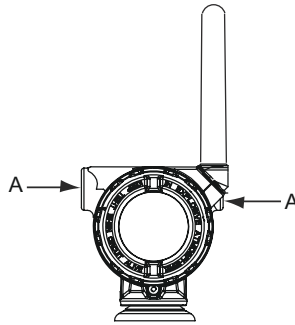

A. Conduit entry

### 1.4 Field Communicator connections

The power module needs to be installed before the Field Communicator can interface with the transmitter. This transmitter uses the Black Power Module; Order model number 701PBKKF or part number 00753-9220-0001.

**Figure 1-3: Connection Diagram**

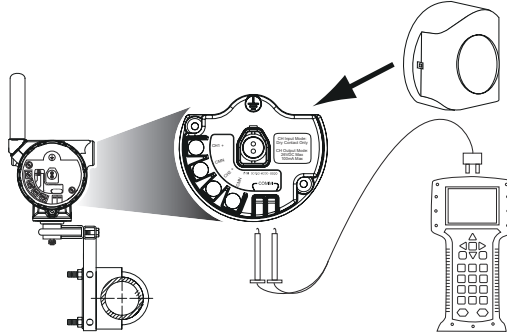

The transmitter and all other wireless devices should not be set up until after the Wireless Gateway has been installed and is functioning properly.

## 2 Mount the transmitter

### 2.1 Liquid flow applications

#### Procedure

1. Place taps to the side of the line.
2. Mount beside or below the taps.
3. Mount the transmitter so that the drain/vent valves are oriented upward.

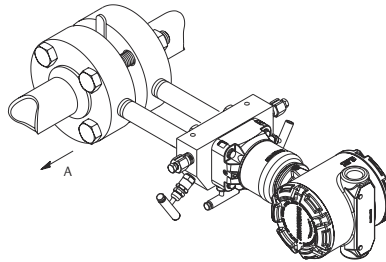

A. Direction of flow

### 2.2 Gas flow applications

#### Procedure

1. Place taps in the top or side of the line.
2. Mount beside or above the taps.

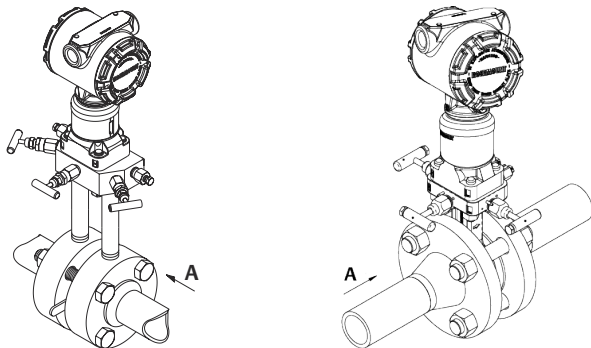

A. Direction of flow

## 2.3 Steam flow applications

### Procedure

1. Place taps to the side of the line.
2. Mount beside or below the taps.
3. Fill impulse lines with water.

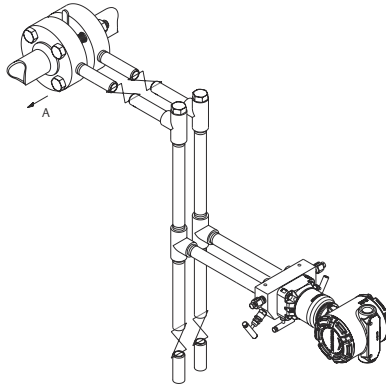

A. Direction of flow



## 2.4 Mounting options

### Panel mounting

---

**Figure 2-1: Coplanar Flange**

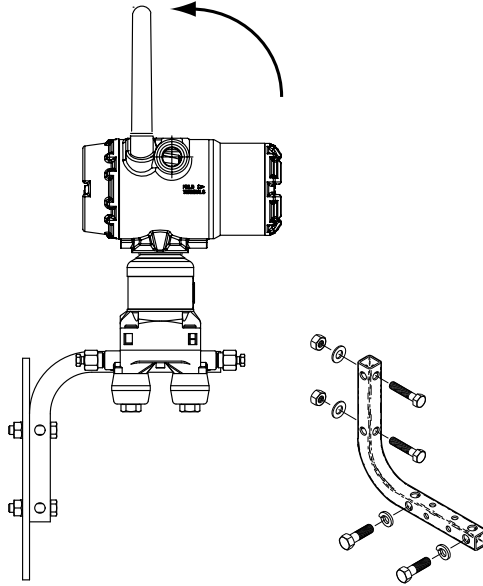

**Figure 2-2: Traditional Flange**

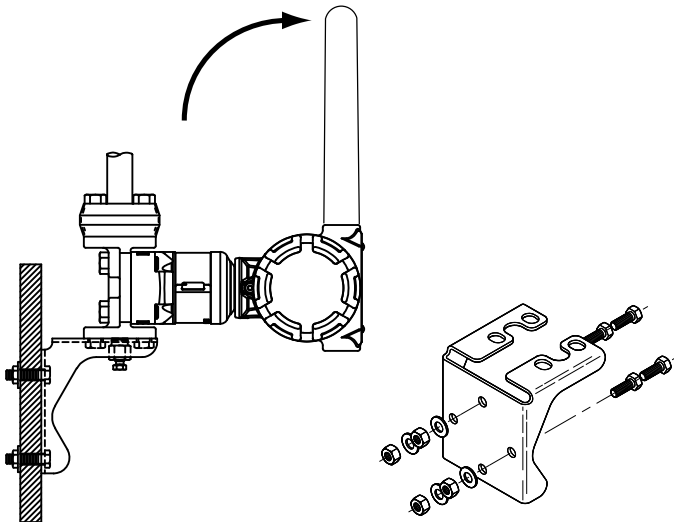

**Figure 2-3: In-line Device**

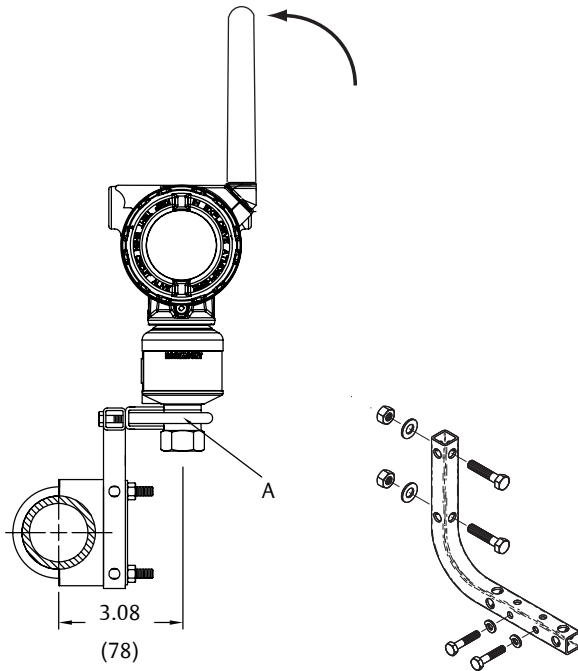

A. U-bolt bracket

**Pipe mounting**

**Figure 2-4: Coplanar Flange**

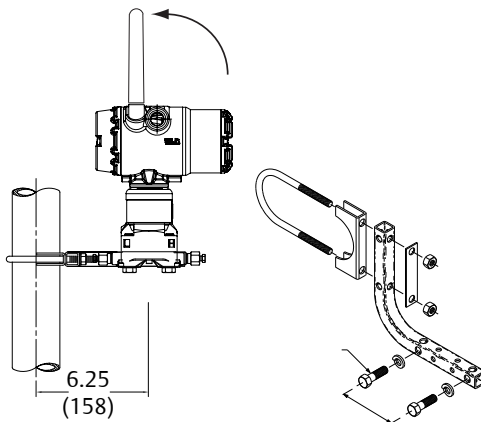

---

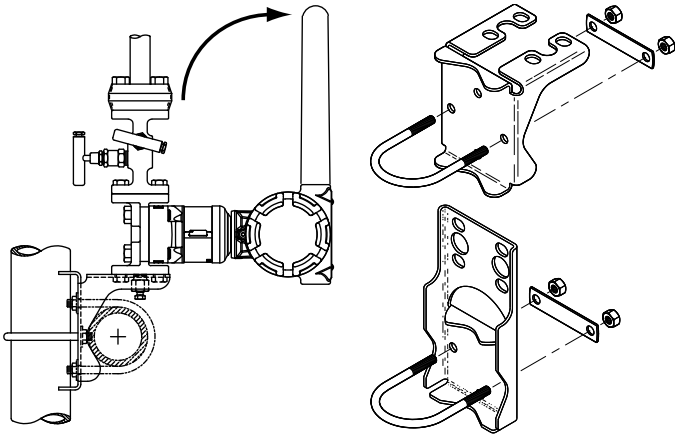
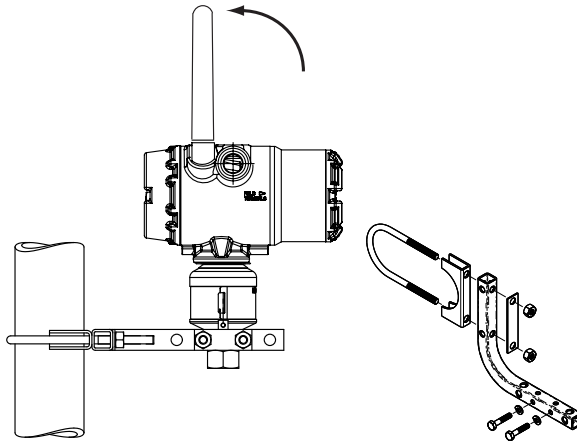
**Figure 2-5: Traditional Flange**

**Figure 2-6: In-line Device**

## 2.5 Bolting considerations

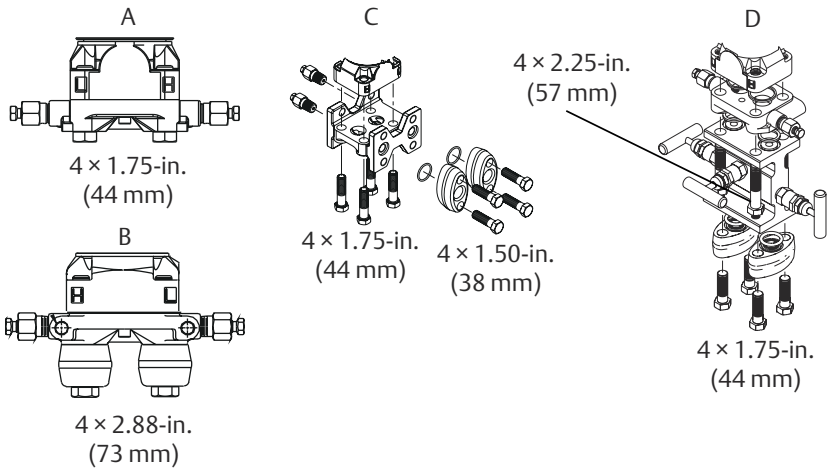
If the transmitter installation requires assembly of a process flange, manifold, or flange adapters, follow these assembly guidelines to ensure a tight seal for optimal performance characteristics of the transmitter. Only use bolts supplied with the transmitter or sold by Emerson™ as spare parts. [Figure 2-7](#) illustrates common transmitter assemblies with the bolt length required for proper transmitter assembly.

**Figure 2-7: Common Transmitter Assemblies**

- A. Transmitter with coplanar flange
- B. Transmitter with coplanar flange and optional flange adapters
- C. Transmitter with traditional flange and optional flange adapters
- D. Transmitter with coplanar flange and optional Rosemount Conventional Manifold and flange adapters

**Note**

For all other manifolds, contact Customer Central technical support.

Bolts are typically carbon steel or stainless steel. Confirm the material by viewing the markings on the head of the bolt and referencing [Table 2-1](#). If bolt material is not shown in [Table 2-1](#), contact the local Emerson representative for more information.

Use the following bolt installation procedure:

**Procedure**

1. Carbon steel bolts do not require lubrication and the stainless steel bolts are coated with a lubricant to ease installation. However, no additional lubricant should be applied when installing either type of bolt.
2. Finger-tighten the bolts.
3. Torque the bolts to the initial torque value using a crossing pattern. See [Table 2-1](#) for initial torque value.
4. Torque the bolts to the final torque value using the same crossing pattern. See [Table 2-1](#) for final torque value.

- Verify the flange bolts are protruding through the sensor module before applying pressure (see [Figure 2-8](#)).

**Example**

**Table 2-1: Torque Values for the Flange and Flange Adapter Bolts**

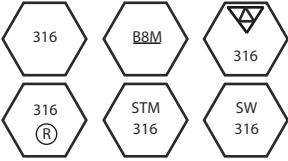
Bolt material	Head markings	Initial torque	Final torque
Carbon Steel (CS)		300 in-lb	650 in-lb
Stainless Steel (SST)		150 in-lb	300 in-lb

**Figure 2-8: Proper Bolt Installation**

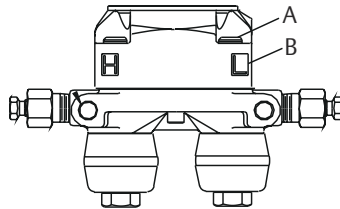

- A. Bolt
- B. Sensor module

## 2.6 O-rings with flange adapters

### **⚠ WARNING**

Failure to install proper flange adapter O-rings may cause process leaks, which can result in death or serious injury. Only use the O-ring that is designed for its specific flange adapter.

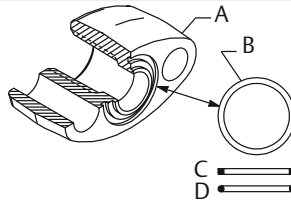

- A. Flange adapter
- B. O-ring
- C. PTFE-based profile (square)
- D. Elastomer profile (round)

Whenever the flange or adapters are removed, visually inspect the O-rings. Replace them if there are any signs of damage, such as nicks or cuts. If the O-rings are replaced, re-torque the flange bolts and alignment screws after installation to compensate for seating of the O-rings.

## 2.7 High gain, remote antenna (optional)

The high gain, remote antenna options provide flexibility for mounting the device based on wireless connectivity, lightning protection, and current work practices.

---

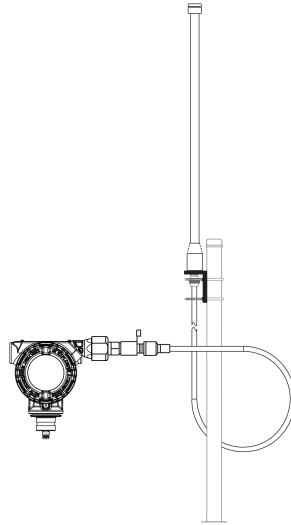
**Figure 2-9: Rosemount 702 Transmitter with High Gain, Remote Antenna**

---

### 2.7.1 Install the high gain, remote antenna (WN option)

#### **Prerequisites**

Find a location where the remote antenna has optimal wireless performance. Ideally this will be 15–25 ft. (4.6–7.6 m) above the ground or 6 ft. (2 m) above obstructions or major infrastructure.

**⚠ WARNING**

When installing remote mount antennas for the transmitter, always use established safety procedures to avoid falling or contact with high-power electrical lines.

Install remote antenna components for the transmitter in compliance with local and national electrical codes and use best practices for lightning protection.

Before installing, consult with the local area electrical inspector, electrical officer, and work area supervisor.

The transmitter remote antenna option is specifically engineered to provide installation flexibility while optimizing wireless performance and local spectrum approvals. To maintain wireless performance and avoid non-compliance with spectrum regulations, do not change the length of cable or the antenna type.

If the supplied remote mount antenna kit is not installed per these instructions, Emerson is not responsible for wireless performance or non-compliance with spectrum regulations.

---

**Procedure**

1. Mount the antenna on a 1.5 to 2-in. pipe mast using the supplied mounting equipment.
2. Connect the lightning arrester directly to the top of the Rosemount Transmitter.
3. Install the grounding lug, lock washer, and nut on top of lightning arrester.
4. Connect the antenna to the lightning arrester using the supplied LMR-400 coaxial cable ensuring the drip loop is not closer than 1 ft. (0.3 m) from the lightning arrester.
5. Use the coaxial sealant to seal each connection between the wireless field device, lightning arrester, cable, and antenna.

---

**Note**

The remote mount antenna kit includes coaxial sealant for weatherproofing the cable connections for the lightning arrester, antenna, and Rosemount 702 Transmitter. Coaxial sealant must be applied to guarantee performance of the wireless field network. See [Figure 2-10](#) for details on how to apply coaxial sealant.

---

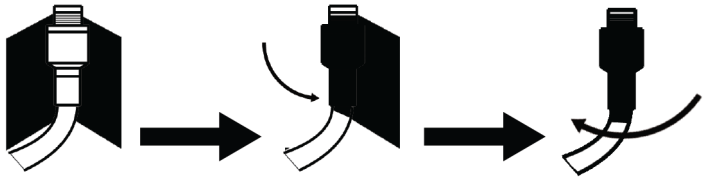

---

**Figure 2-10: Applying Coaxial Sealant to Cable Connections**

6. Ensure the mounting mast and lightning arrester are grounded according to local/national electrical code.

Any spare lengths of coaxial cable should be placed in 12-in. (0.3 m) coils.

## 3 Connect the power module

### Procedure

1. Remove the housing cover on the field terminal side.
2. Connect the black power module.

## 4 Trim the transmitter

Transmitters are shipped fully calibrated per request or by the factory default of full scale (span = upper range limit).

### 4.1 Zero trim

A zero trim is a single-point adjustment used for compensating mounting position and line pressure effects. When performing a zero trim, ensure the equalizing valve is open and all wet legs are filled to the correct level.

## 5 Close the housing

### Procedure

1. Close the housing cover and tighten to safety specification.
2. Always ensure a proper seal by installing the electronics housing covers so that metal contacts metal, but do not over tighten.

## 6 Verify operation

There are four methods available to verify operation:

- Using the optional local display (LCD)
- Using the Field Communicator
- Using the Wireless Gateway’s integrated web interface
- Using AMS Suite Wireless Configurator



If the device was configured with the Network ID and Join Key, and sufficient time has passed, the transmitter will be connected to the network.

### 6.1 Local display (LCD display)

The LCD display will show the output values based on the wireless update rate. Refer to the Rosemount 3051S and 3051SMV Wireless manuals for error codes and other LCD display messages..

#### Procedure

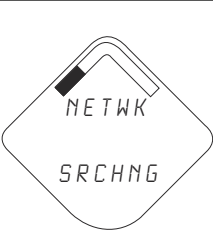
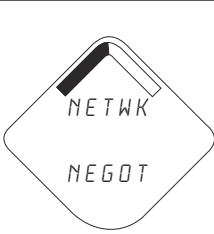
Press and hold the **Diagnostic** button for at least five seconds to display the TAG, Device ID, Network ID, Network Join Status, and Device Status screens.

Searching for network	Joining network	Connected with limited bandwidth	Connected
			

### 6.2 Field Communicator

For HART Wireless transmitter communication, an appropriate DD is required. For connecting with a Field Communicator, refer to [Field Communicator connections](#).

Function	Fast Key sequence	Menu Items
Communications	3, 4	Join Status, Wireless Mode, Join Mode, Number of Available Neighbors, Number of Advertisements Heard, Number of Join Attempts

## 6.3 Wireless Gateway

In the Gateway’s integrated web interface, navigate to the **Explorer > Status** page. This page will show whether the device has joined the network and if it is communicating properly.

### Note

It may take several minutes for the device to join the network. See Emerson Wireless Gateway [Quick Start Guide](#) for more information.

Figure 6-1: Gateway Network Settings

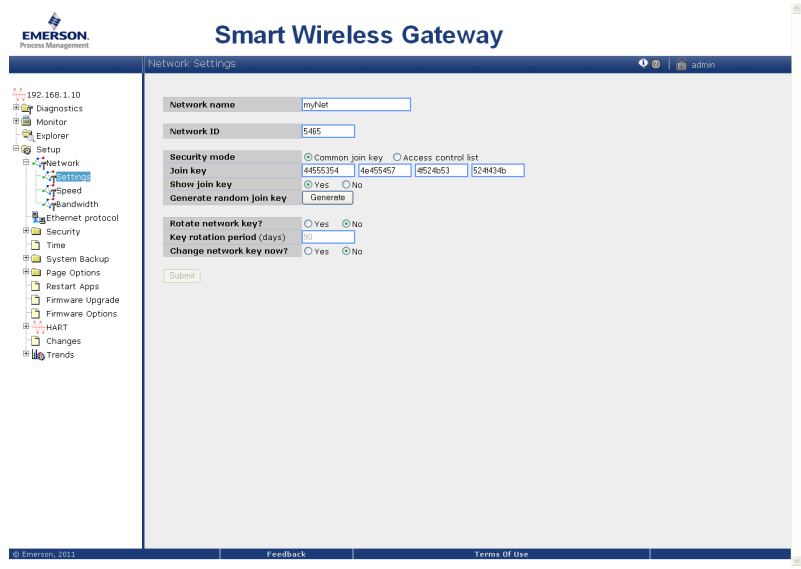

## 6.4 AMS Wireless Configurator

When the device has joined the network, it will appear in AMS Wireless Configurator as illustrated below.

**Figure 6-2: AMS Wireless Configurator, Device Explorer Screen**

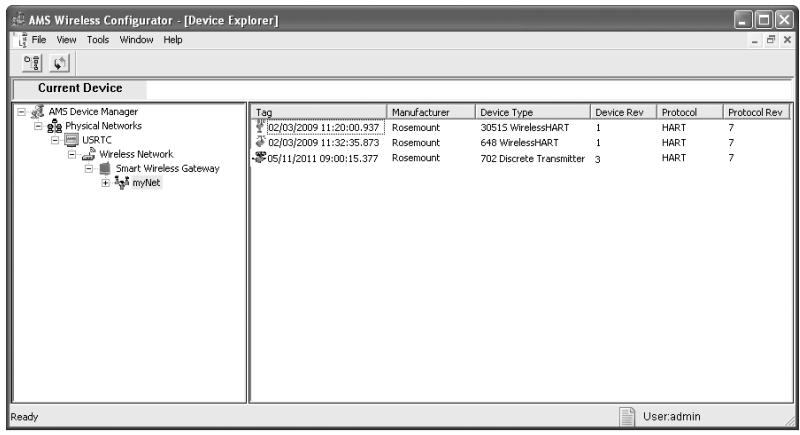

## 6.5 Troubleshooting

If the device is not joined to the network after power up, verify the correct configuration of the network ID and join key, and verify the active advertising has been enabled on the Gateway. The network ID and join key in the device must match the network ID and join key of the Gateway.

The network ID and join key may be obtained from the Gateway on the **Setup > Network > Settings** page on the web interface (see [Figure 6-1](#)). The network ID and join key may be changed in the wireless device by using the following Fast Key sequence.

Function	Fast Key sequence	Menu items
Communications	3, 4	Join Status, Wireless Mode, Join Mode, Number of Available Neighbors, Number of Advertisements Heard, Number of Join Attempts

## 7 Reference information

**Figure 7-1: Terminal Diagram**

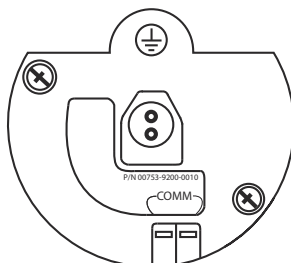

For connecting with a Field Communicator, refer to [Figure 1-3](#).

**Table 7-1: HART Fast Key Sequence**

Function	Fast Key sequence	Menu items
Device Info <sup>(1)</sup>	2, 2, 9	Manufacturer, Model, Final Assembly Number, Universal, Field Device, Software, Hardware, Descriptor, Message, Date, Model Number I, II, III, SI Unit Restriction, Country
Guided Setup	2, 1	Configure Basic Setup, Zero Sensor Trim, Join Device to Network, Update Rate, Device Display, Alert Setup, Scaled Variable
Manual Setup	2, 2	Configure, Manual Setup, Wireless, Pressure, Device Temperatures, Device Information, Display, Scaled Variable, Other
Wireless	2, 2, 1	Network ID, Join Device to Network, Configure Update Rate, Configure Broadcast Power Level, Power Mode, Power Source

(1) If using Rosemount 3051SMV, use the Fast Key sequence 2, 2 and then navigate to Device Information.

### Note

If using Rosemount 3051SMV, use the Fast Key sequence 2, 2 and then navigate to **Device Information**.



## 8 Rosemount 3051S and 3051SMV Wireless Product Certifications

Rev 2.4

### European directive information

A copy of the EC Declaration of Conformity can be found at the end of the Quick Start Guide. The most recent revision of the EC Declaration of Conformity can be found at [Emerson.com/Rosemount](http://Emerson.com/Rosemount).

### Telecommunication Compliance

All wireless devices require certification to ensure that they adhere to regulations regarding the use of the RF spectrum. Nearly every country requires this type of product certification.

Emerson is working with governmental agencies around the world to supply fully compliant products and remove the risk of violating country directives or laws governing wireless device usage.

### FCC and IC

This device complies with Part 15 of the FCC Rules. Operation is subject to the following conditions: This device may not cause harmful interference. This device must accept any interference received, including interference that may cause undesired operation. This device must be installed to ensure a minimum antenna separation distance of 20 cm from all persons.

### Ordinary location certification

As standard, the transmitter has been examined and tested to determine that the design meets the basic electrical, mechanical, and fire protection requirements by a nationally recognized test laboratory (NRTL) as accredited by the Federal Occupational Safety and Health Administration (OSHA).

### Installing Equipment in North America

The US National Electrical Code (NEC) and the Canadian Electrical Code (CEC) permit the use of Division marked equipment in Zones and Zone marked equipment in Divisions. The markings must be suitable for the area classification, gas, and temperature class. This information is clearly defined in the respective codes.

## 8.1 USA

### 8.1.1 I5 USA Intrinsically Safe (IS), Nonincendive (NI), and Dust-Ignitionproof (DIP)

**Certificate** FM18US0009X

- Standards** FM Class 3600 – 2011, FM Class 3610 – 2010, FM Class 3611 – 2004, FM Class 3810 – 2005, NEMA® 250 – 2003
- Markings** IS CL I, DIV 1, GP A, B, C, D; CL II, DIV 1, GP E, F, G; CL III T4; CL 1, Zone 0 AEx ia IIC T4; NI CL 1, DIV 2, GP A, B, C, D T4; DIP CL II, DIV 1, GP E, F, G; CL III, T5; T4(–50 °C ≤ Ta ≤ +70 °C)/ T5(–50 °C ≤ Ta ≤ +85 °C); when connected per Rosemount drawing 03151-1000; Type 4X

### Special Conditions for Safe Use (X):

1. The Rosemount 3051S and SMV Wireless Transmitters shall only be used with the 701PBKKF Rosemount SmartPower Battery Pack (P/N 00753-9220-0001), Computational Systems Inc Battery Pack (P/N MHM-89004) or alternatively the Perpetuum Intelligent Power Module Vibration Harvester (P/N IPM71008).
2. The transmitter may contain more than 10% aluminum and is considered a potential risk of ignition by impact or friction. Care must be taken into account during installation and use to prevent impact and friction.
3. The surface resistivity of the antenna is greater than 1GΩ. To avoid electrostatic charge build-up, it must not be rubbed or cleaned with solvents or a dry cloth.

## 8.2 Canada

### 8.2.1 I6 Canada Intrinsically Safe

- Certificate** CSA 1143113
- Standards** CAN/CSA C22.2 No. 0-10, CSA Std C22.2 No. 30-M1986, CAN/CSA C22.2 No. 94-M91, CSA Std C22.2 No. 142-M1987, CSA Std C22.2 No. 157-92, ANSI/ISA 12.27.01-2003, CSA Std C22.2 No. 60529:05
- Markings** Intrinsically Safe Class I, Division 1; suitable for Class 1, Zone 0, IIC, T3C; when connected per Rosemount drawing 03151-1010; Type 4X

## 8.3 Europe

### 8.3.1 I1 ATEX Intrinsic Safety

- Certificate** Baseefa13ATEX0127X
- Standards** EN 60079-0: 2012, EN 60079-11: 2012
- Markings**  II 1 G Ex ia IIC T4 Ga, T4(–60 °C ≤ Ta ≤ +70 °C)

**Special Conditions for Safe Use (X):**

1. The Rosemount 3051S Wireless and Rosemount 3051SMV Wireless enclosure may be made of aluminum alloy and given a protective polyurethane paint finish; however, care should be taken to protect it from impact or abrasion if located in a zone 0 area.
2. The surface resistivity of the antenna is greater than 1 GΩ. To avoid electrostatic charge build-up, it must not be rubbed or cleaned with solvents or dry cloth.

**8.4 International****8.4.1 I7 IECEx Intrinsic Safety**

<b>Certificate</b>	IECEx BAS 13.0068X
<b>Standards</b>	IEC 60079-0:2011, IEC 60079-11:2011
<b>Markings</b>	Ex ia IIC T4 Ga, T4(-60 °C ≤ T <sub>a</sub> ≤ +70 °C)

**Special Conditions for Safe Use (X):**

1. The Rosemount 3051S Wireless and Rosemount 3051SMV Wireless enclosure may be made of aluminum alloy and given a protective polyurethane paint finish; however, care should be taken to protect it from impact or abrasion if located in a zone 0 area.
2. The surface resistivity of the antenna is greater than 1GΩ . To avoid electrostatic charge build-up, it must not be rubbed or cleaned with solvents or dry cloth.

**8.5 Brazil****8.5.1 I2 INMETRO Intrinsic Safety**

<b>Certificate</b>	UL-BR 14.0760X
<b>Standards</b>	ABNT NBR IEC60079-0:2008 + Errata 1:2011, ABNT NBR IEC60079-11: 2009
<b>Markings</b>	Ex ia IIC T4 Ga, T4(-60 °C ≤ T <sub>a</sub> ≤ +70 °C)

**Special Condition for Safe Use (X):**

1. See certificate.

**8.6 China****8.6.1 I3 China Intrinsic Safety**

<b>Certificate</b>	3051S Wireless: GYJ161250X 3051SFX: GYJ16.1465X [flow meters]
--------------------	------------------------------------------------------------------

**Standards** GB3836.1-2010, GB3836.4-2010, GB3836.20-2010

**Markings** Ex ia IIC T4 Ga, T4(-60~70 °C)

**Special Condition for Safe Use (X):**

1. See appropriate certificate.

**Note**

Not currently available on the Rosemount 3051S MultiVariable Wireless Transmitter.

## 8.7 Japan

### 8.7.1 I4 TIIS Intrinsically Safe

**Certificate** TC18649, TC18650, TC18657

**Markings** Ex ia IIC T4, T4(-20~60 °C)

**Note**

Not currently available on the Rosemount 3051S MultiVariable Wireless Transmitter.

## 8.8 EAC - Belarus, Kazakhstan, Russia

### 8.8.1 IM EAC Intrinsic Safety

**Certificate** TC RU C-US.AA87.B.00378

**Markings** 0Ex ia IIC T4 Ga X (-60 °C ≤ T<sub>a</sub> ≤ +70 °C)

**Special Condition for Safe Use (X):**

1. See certificate for special conditions.

**Note**

Not currently available on the Rosemount 3051S MultiVariable Wireless Transmitter.

## 8.9 Republic of Korea

### 8.9.1 IP Korea Intrinsic Safety

**Certificates** 12-KB4BO-0202X, 12-KB4BO-0203X

**Markings** Ex ia IIC T4, (-60 °C ≤ T<sub>a</sub> ≤ +70 °C)

**Note**

Not currently available on the Rosemount 3051S MultiVariable Wireless Transmitter.



**Special Condition for Safe Use (X):**



1. See certificate for special conditions.

## 8.10 Combinations

**KQ**      Combination of I1, I5, and I6

# 8.11 Rosemount 3051S Wireless Declaration of Conformity

	<h2>EU Declaration of Conformity</h2> <p>No: RMD 1099 Rev. I</p>	
<p>We,</p>		
<p><b>Rosemount, Inc.</b>  <b>8200 Market Boulevard</b>  <b>Chanhassen, MN 55317-9685</b>  <b>USA</b></p>		
<p>declare under our sole responsibility that the product,</p>		
<p><b>Rosemount™ 3051S &amp; 300S Wireless Pressure Transmitters,</b>  <b>3051SFx Wireless Flowmeter Transmitters,</b>  <b>and 3051SMV &amp; 300SMV Wireless Pressure Transmitters</b></p>		
<p>manufactured by,</p>		
<p><b>Rosemount, Inc.</b>  <b>8200 Market Boulevard</b>  <b>Chanhassen, MN 55317-9685</b>  <b>USA</b></p>		
<p>to which this declaration relates, is in conformity with the provisions of the European Union Directives, including the latest amendments, as shown in the attached schedule.</p>		
<p>Assumption of conformity is based on the application of the harmonized standards and, when applicable or required, a European Union notified body certification, as shown in the attached schedule.</p>		
	<p>Vice President of Global Quality (function)</p>	
<p>(signature)</p>		
<p>Chris LaPoint (name)</p>	<p>1-Feb-19; Shakopee, MN USA (date of issue &amp; place)</p>	
<p>Page 1 of 3</p>		

	<h1>EU Declaration of Conformity</h1> <p>No: RMD 1099 Rev. I</p>	
<p><b>EMC Directive (2014/30/EU)</b></p> <p>Harmonized Standards:          EN 61326-1:2013          EN 61326-2-3:2013</p>		
<p><b>Radio Equipment Directive (RED) (2014/53/EU)</b></p> <p>Harmonized Standards:          EN 300 328 V2.1.1          EN 301 489-1 V2.2.0          EN 301 489-17 V3.2.0          EN 61010-1: 2010          EN 62311: 2008</p>		
<p><b>PED Directive (2014/68/EU)</b></p> <p><b>Rosemount™ 3051S_CA4; 3051S_CD2, 3, 4, 5 (also with P0 &amp; P9 option)</b>          QS Certificate of Assessment – EC Certificate No. 12698-2018-CE-ACCREDIA          Module H Conformity Assessment          Other Standards Used:          ANSI / ISA 61010-1:2004          IEC 60770-1:1999  <i>Note – previous PED Certificate No. 59552-2009-CE-HOU-DNV</i></p> <p><b>All other Rosemount™ 3051S &amp; 3051SMV Pressure Transmitters</b>          Sound Engineering Practice</p> <p><b>Transmitter Attachments: Diaphragm Seal, Process Flange, or Manifold</b>          Sound Engineering Practice</p> <p><b>Rosemount 3051SFx Series Flowmeter Pressure Transmitters</b>          Refer to Declaration of Conformity DS11000</p>		
<p>Page 2 of 3</p>		

	<b>EU Declaration of Conformity</b> No: RMD 1099 Rev. I	
<b>ATEX Directive (2014/34/EU)</b>		
<b>Baseefa13ATEX0127X – Intrinsic Safety Certificate</b> Equipment Group II, Category 1 G Ex ia IIC T4 Ga Harmonized Standards: EN 60079-0:2012+A11:2013 EN 60079-11:2012		
<hr/>		
<b>PED Notified Body</b>		
<b>DNV GL Business Assurance Italia S.r.l.</b> [Notified Body Number: 0496] Via Energy Park 14, N-20871 Vimercate (MB), Italy <i>Note – equipment manufactured prior to 20 October 2018 may be marked with the previous PED Notified Body number; previous PED Notified Body information was as follows: Det Norske Veritas (DNV) [Notified Body Number: 0575] Veritasveien 1, N-1322 Hovik, Norway</i>		
<b>ATEX Notified Body</b>		
<b>SGS FIMCO OY</b> [Notified Body Number: 0598] P.O. Box 30 (Särkiniementie 3) 00211 HELSINKI Finland		
<b>ATEX Notified Body for Quality Assurance</b>		
<b>SGS FIMCO OY</b> [Notified Body Number: 0598] P.O. Box 30 (Särkiniementie 3) 00211 HELSINKI Finland		
<p style="text-align: center;">Page 3 of 3</p>		



## 8.12 China RoHS

含有China RoHS管控物质超过最大浓度限值的部件型号列表 Rosemount 3051S  
List of Rosemount 3051S Parts with China RoHS Concentration above MCVs

部件名称 Part Name	有害物质 / Hazardous Substances					
	铅 Lead (Pb)	汞 Mercury (Hg)	镉 Cadmium (Cd)	六价铬 Hexavalent Chromium (Cr +6)	多溴联苯 Polybrominated biphenyls (PBB)	多溴联苯醚 Polybrominated diphenyl ethers (PBDE)
电子组件 Electronics Assembly	X	O	O	O	O	O
壳体组件 Housing Assembly	X	O	O	X	O	O
传感器组件 Sensor Assembly	X	O	O	X	O	O

本表格系依据SJ/T11364的规定而制作。

This table is proposed in accordance with the provision of SJ/T11364.

O: 意为该部件的所有均质材料中该有害物质的含量均低于GB/T 26572所规定的限量要求。

O: Indicate that said hazardous substance in all of the homogeneous materials for this part is below the limit requirement of GB/T 26572.

X: 意为在该部件所使用的的所有均质材料里，至少有一类均质材料中该有害物质的含量高于GB/T 26572所规定的限量要求。



X: Indicate that said hazardous substance contained in at least one of the homogeneous materials used for this part is above the limit requirement of GB/T 26572.









### **Global Headquarters**

Emerson Automation Solutions  
6021 Innovation Blvd.  
Shakopee, MN 55379, USA  
 +1 800 999 9307 or +1 952 906 8888  
 +1 952 949 7001  
 RFQ.RMD-RCC@Emerson.com

### **Latin America Regional Office**

Emerson Automation Solutions  
1300 Concord Terrace, Suite 400  
Sunrise, FL 33323, USA  
 +1 954 846 5030  
 +1 954 846 5121  
 RFQ.RMD-RCC@Emerson.com

### **Asia Pacific Regional Office**

Emerson Automation Solutions  
1 Pandan Crescent  
Singapore 128461  
 +65 6777 8211  
 +65 6777 0947  
 Enquiries@AP.Emerson.com

 [Linkedin.com/company/Emerson-Automation-Solutions](https://www.linkedin.com/company/Emerson-Automation-Solutions)

 [Twitter.com/Rosemount\\_News](https://twitter.com/Rosemount_News)

 [Facebook.com/Rosemount](https://www.facebook.com/Rosemount)

 [Youtube.com/user/RosemountMeasurement](https://www.youtube.com/user/RosemountMeasurement)

 [Google.com/+RosemountMeasurement](https://www.google.com/+RosemountMeasurement)

### **North America Regional Office**

Emerson Automation Solutions  
8200 Market Blvd.  
Chanhassen, MN 55317, USA  
 +1 800 999 9307 or +1 952 906 8888  
 +1 952 949 7001  
 RMT-NA.RCCRF@Emerson.com

### **Europe Regional Office**

Emerson Automation Solutions Europe GmbH  
Neuhofstrasse 19a P.O. Box 1046  
CH 6340 Baar  
Switzerland  
 +41 (0) 41 768 6111  
 +41 (0) 41 768 6300  
 RFQ.RMD-RCC@Emerson.com

### **Middle East and Africa Regional Office**

Emerson Automation Solutions  
Emerson FZE P.O. Box 17033  
Jebel Ali Free Zone - South 2  
Dubai, United Arab Emirates  
 +971 4 8118100  
 +971 4 8865465  
 RFQ.RMTMEA@Emerson.com

©2019 Emerson. All rights reserved.

Emerson Terms and Conditions of Sale are available upon request. The Emerson logo is a trademark and service mark of Emerson Electric Co. Rosemount is mark of one of the Emerson family of companies. All other marks are the property of their respective owners.