

Rosemount™ 8732EM Transmitter with HART Protocol

Includes support for 8750W



1 Safety

⚠ WARNING

- Failure to follow these installation guidelines could result in serious injury or death.
 - Installation and servicing instructions are for use by qualified personnel only. Do not perform any servicing other than that contained in the operating instructions, unless qualified.
 - Potential electrostatic charging hazard: Rosemount Magnetic flow meters ordered with non-standard paint options or non-metallic labels may be subject to electrostatic discharge. To avoid electrostatic charge build-up, do not rub the flow meter with a dry cloth or clean with solvents.
 - Verify that the operating environment of the sensor and transmitter is consistent with the appropriate Agency Approval.
 - If installed in an explosive atmosphere, verify that the device certification and installation techniques are suitable for that particular environment.
 - To prevent ignition of flammable or combustible atmosphere, disconnect power before servicing circuits.
 - Explosion hazard: Do not disconnect equipment when a flammable or combustible atmosphere is present.
 - Do not connect a Rosemount Transmitter to a non-Rosemount sensor when installed in an "Ex" environment, explosive atmosphere, hazardous area, or classified area.
 - Follow national, local, and plant standards to properly earth ground the transmitter and sensor. The earth ground must be separate from the process reference ground.
 - Shock hazard: Shut off power before servicing. Do not operate without power compartment cover.
-

⚠ CAUTION

- In cases where high voltage/high current are present near the meter installation, ensure proper protection methods are followed to prevent stray voltage/current from passing through the meter. Failure to adequately protect the meter could result in damage to the transmitter and lead to meter failure.
 - Completely remove all electrical connections from both sensor and transmitter prior to welding on the pipe. For maximum protection of the sensor, consider removing it from the pipeline.
-

2 Introduction

This document provides basic installation guidelines for the Rosemount 8732EM field-mount transmitter.

- For sensor installation, refer to the *Rosemount™ 8700 Magnetic Flow Meter Sensor Quick Installation Guide* .
- For additional installation information, configuration, maintenance, and troubleshooting, refer to the *Rosemount™ 8732EM Transmitter with HART Protocol Reference Manual* .

All user documentation can be found at www.emerson.com. For more contact information, see [Emerson Flow customer service](#).

2.1 Return policy

Emerson procedures must be followed when returning equipment. These procedures ensure legal compliance with government transportation agencies and help provide a safe working environment for Emerson employees. Failure to follow Emerson procedures will result in your equipment being refused delivery.

2.2 Emerson Flow customer service

Email:

- Worldwide: flow.support@emerson.com
- Asia-Pacific: APflow.support@emerson.com

3 Pre-installation

Before installing the transmitter, there are several pre-installation steps that should be completed to make the installation process easier:

- Identify options and configurations that apply to your application
- Set the hardware switches if necessary
- Consider mechanical, electrical, and environmental requirements

Note

Refer to the product reference manual for more detailed requirements.

Identify options and configurations

The typical transmitter installation includes a device power connection, a 4-20mA output connection, and sensor coil and electrode connections. Other applications may require one or more of the following configurations or options

- Pulse output
- Discrete input/discrete output
- HART multidrop configuration

Hardware switches

The transmitter may have up to four user-selectable hardware switches. These switches set the alarm mode, internal/external analog power, internal/external pulse power, and transmitter security. The standard configuration for these switches when shipped from the factory is as follows:

Table 3-1: Hardware switch default settings

Setting	Factory configuration
Alarm mode	High
Internal/external analog power	Internal
Internal/external pulse power	External
Transmitter security	Off

The analog power switch and pulse power switches are not available when ordered with intrinsically safe output, ordering code B.

In most cases, it is not necessary to change the setting of the hardware switches. If the switch settings need to be changed, refer to the product reference manual.

Be sure to identify any additional options and configurations that apply to the installation. Keep a list of these options for consideration during the installation and configuration procedures.

Mechanical considerations

The mounting site for the transmitter should provide enough room for secure mounting, easy access to conduit entries, full opening of the transmitter covers, and easy readability of the Local Operator Interface (LOI) screen (if equipped).

Figure 3-1: Rosemount 8732EM Dimensional Drawing

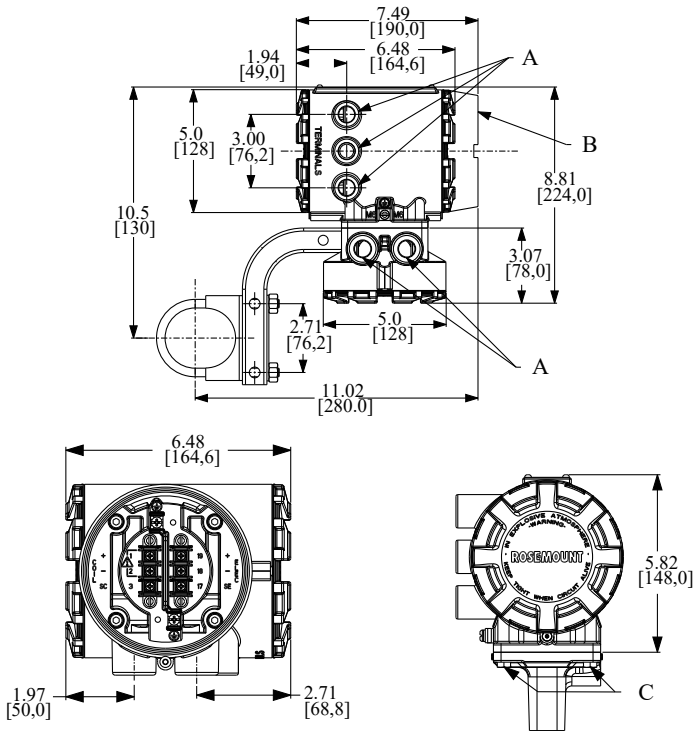

- A. Conduit entry ½-14 NPT or M20
- B. LOI cover
- C. Mounting screws

Electrical considerations

Before making any electrical connections to the transmitter, consider national, local, and plant electrical installation requirements. Be sure to have the proper power supply, conduit, and other accessories necessary to comply with these standards.

The transmitter requires external power. Ensure access to a suitable power source.

Table 3-2: Electrical Data

Rosemount 8732EM Flow Transmitter	
Power input	AC power: 90–250VAC, 0.45A, 40VA
	Standard DC power: 12–42VDC, 1.2A, 15W
	Low power DC: 12–30VDC, 0.25A, 3W
Pulsed circuit	Internally powered (Active): Outputs up to 12VDC, 12.1mA, 73mW Externally powered (Passive): Input up to 28VDC, 100mA, 1W
4-20mA output circuit	Internally Powered (Active): Outputs up to 25mA, 24VDC, 600mW Externally Powered (Passive): Input up to 25mA, 30VDC, 750mW
Um	250V
Coil excitation output	500mA, 40V max, 9W max

Environmental considerations

To ensure maximum transmitter life, avoid extreme temperatures and excessive vibration. Typical problem areas include the following:

- High-vibration lines with integrally mounted transmitters
- Tropical or desert installations in direct sunlight
- Outdoor installations in arctic climates

Remote mounted transmitters may be installed in the control room to protect the electronics from the harsh environment and to provide easy access for configuration or service.

Table 3-3: Transmitter housing environmental ratings

Type	Rating
Ingress protection	IP66, IP69
NEMA	4X
Pollution Degree	2
Maximum altitude rating	<ul style="list-style-type: none">• 13,123 ft (4000 m) at rated input power voltage (90–250 VAC)• 16,404 ft (5000 m) at maximum input power voltage of 150 VAC

Note

For complete environmental and other specifications, see Product specifications in [Rosemount™ 8732EM Transmitter with HART Protocol Reference Manual](#).

4 Mounting

Remote-mount transmitters are shipped with a mounting bracket for use on a 2-in. pipe or a flat surface.

Figure 4-1: Rosemount 8732 transmitter mounting hardware

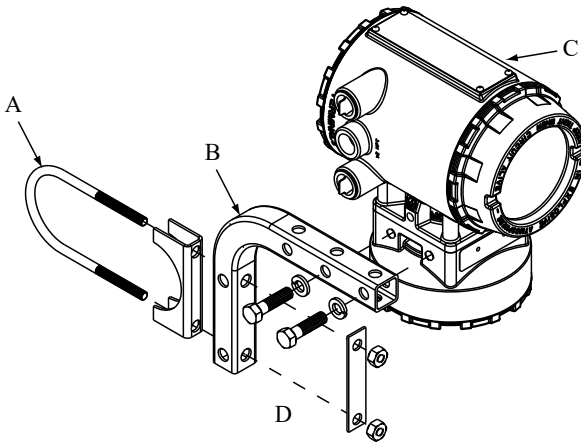

- A. U-bolt
- B. Mounting bracket
- C. Transmitter
- D. Fasteners (example configuration)

Procedure

1. Assemble the hardware as needed to accommodate the mounting configuration.
2. Secure the transmitter to the mounting hardware.

Postrequisites

The LOI/Display can be rotated in 90 degree increments up to 180 degrees if desired. Do not rotate more than 180 degrees in any one direction.

5 Wiring

5.1 Conduit entries and connections

Transmitter conduit entry ports can be ordered with ½"-14NPT or M20 female threaded connections. Conduit connections should be made in accordance with national, local, and plant electrical codes. Unused conduit entries should be sealed with the appropriate certified plugs. The plastic shipping plugs do not provide ingress protection.

5.2 Conduit requirements

- For installations with an intrinsically safe electrode circuit, a separate conduit for the coil cable and the electrode cable may be required. Refer to the product reference manual.
- For installations with non-intrinsically safe electrode circuit, or when using the combination cable, a single dedicated conduit run for the coil drive and electrode cable between the sensor and the remote transmitter may be acceptable. Removal of the barriers for intrinsic safety isolation is permitted for non-intrinsically safe electrode installations.
- Bundled cables from other equipment in a single conduit are likely to create interference and noise in the system. See [Figure 5-1](#).
- Electrode cables should not be run together in the same cable tray with power cables.
- Output cables should not be run together with power cables.
- Select conduit size appropriate to feed cables through to the flowmeter.

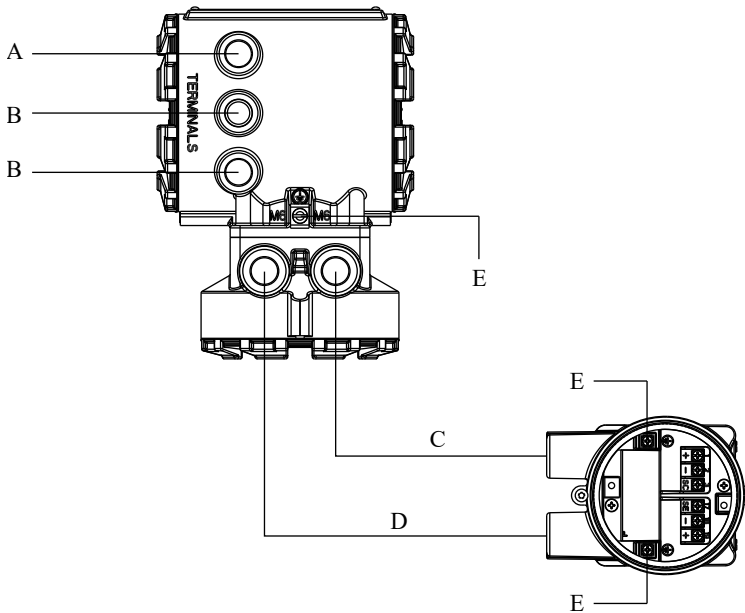
Figure 5-1: Best practice conduit preparation

- A. Power
- B. Output
- C. Coil
- D. Electrode
- E. Safety ground

5.3 Sensor to transmitter wiring

Integral mount transmitters

Integral mount transmitters ordered with a sensor will be shipped assembled and wired at the factory using an interconnecting cable. Use only the factory supplied cable provided with the instrument. For replacement transmitters use the existing interconnecting cable from the original assembly. Replacement cables, if applicable, are available (see [Figure 5-2](#)).

Figure 5-2: Replacement interconnecting cables

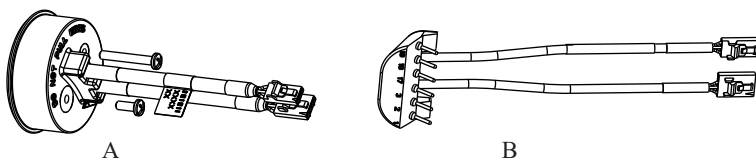

- A. Socket module 08732-CSKT-0001
- B. IMS cable 08732-CSKT-0004

Remote mount transmitters

Remote cable kits are available as individual component cables or as a combination coil/electrode cable. They can be ordered directly using the kit numbers shown in [Table 5-1](#), [Table 5-2](#), and [Table 5-3](#). Equivalent Alpha cable part numbers are also provided as an alternative. To order cable, specify length as quantity desired. Equal length of component cables is required.

Examples:

- 25 feet = Qty (25) 08732-0065-0001
- 25 meters = Qty (25) 08732-0065-0002

Table 5-1: Component cable kits - standard temperature (-20°C to 75°C)

Cable kit #	Description	Individual cable	Alpha p/n
08732-0065-0001 (feet)	Kit, component cables, Std temp (includes Coil and Electrode)	Coil Electrode	2442C 2413C
08732-0065-0002 (meters)	Kit, component cables, Std temp (includes Coil and Electrode)	Coil Electrode	2442C 2413C
08732-0065-0003 (feet)	Kit, component cables, Std temp (includes Coil and I.S. Electrode)	Coil Intrinsically Safe Blue Electrode	2442C Not available
08732-0065-0004 (meters)	Kit, component cables, Std temp (includes Coil and I.S. Electrode)	Coil Intrinsically Safe Blue Electrode	2442C Not available

Table 5-2: Component cable kits - extended temperature (-50°C to 125°C)

Cable kit #	Description	Individual cable	Alpha p/n
08732-0065-1001 (feet)	Kit, Component Cables, Ext Temp. (includes Coil and Electrode)	Coil Electrode	Not available Not available
08732-0065-1002 (meters)	Kit, Component Cables, Ext Temp. (includes Coil and Electrode)	Coil Electrode	Not available Not available
08732-0065-1003 (feet)	Kit, Component Cables, Ext Temp. (includes Coil and I.S. Electrode)	Coil Intrinsically Safe Blue Electrode	Not available Not available
08732-0065-1004 (meters)	Kit, Component Cables, Ext Temp. (includes Coil and I.S. Electrode)	Coil Intrinsically Safe Blue Electrode	Not available Not available

Table 5-3: Combination cable kits - coil and electrode cable (-20°C to 80°C)

Cable kit #	Description
08732-0065-2001 (feet)	Kit, Combination Cable, Standard
08732-0065-2002 (meters)	
08732-0065-3001 (feet)	Kit, Combination Cable, Submersible (80°C dry/60°C Wet) (33ft Continuous)
08732-0065-3002 (meters)	

Cable requirements

Shielded twisted pairs or triads must be used. For installations using the individual coil drive and electrode cable, see [Figure 5-3](#). Cable lengths should be limited to less than 500 feet (152 m). Consult factory for length between 500–1000 feet (152–304 m). Equal length cable is required for each. For installations using the combination coil drive/electrode cable, see [Figure 5-4](#). Combination cable lengths should be limited to less than 330 feet (100 m).

Figure 5-3: Individual component cables

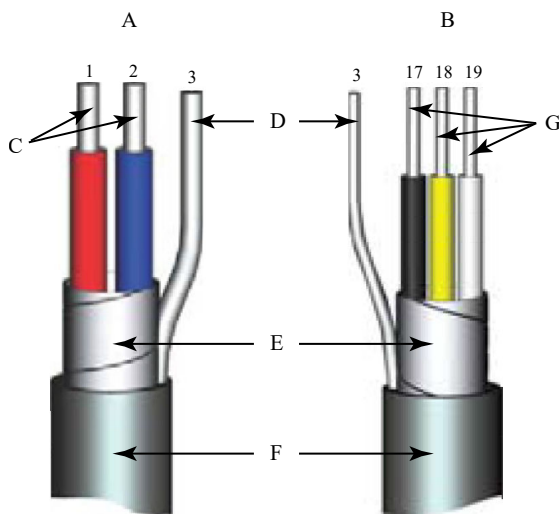

- A. Coil drive
- B. Electrode
- C. Twisted, stranded, insulated 14 AWG conductors
- D. Drain
- E. Overlapping foil shield
- F. Outer jacket
- G. Twisted, stranded, insulated 20 AWG conductors

- 1 = Red
- 2 = Blue
- 3 = Drain
- 17 = Black
- 18 = Yellow
- 19 = White

Figure 5-4: Combination coil and electrode cable

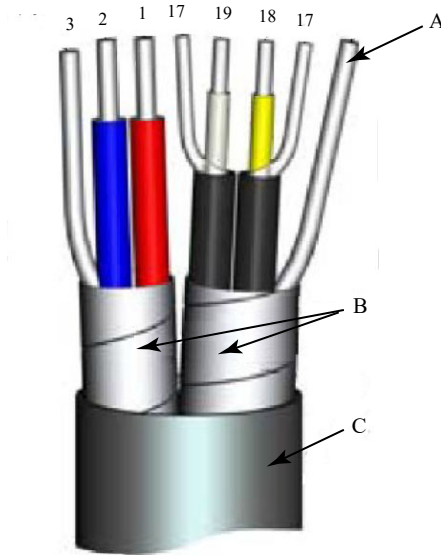

- A. Electrode shield drain*
- B. Overlapping foil shield*
- C. Outer jacket*

- 1 = Red
- 2 = Blue
- 3 = Drain
- 17 = Reference
- 18 = Yellow
- 19 = White

Cable preparation

Prepare the ends of the coil drive and electrode cables as shown in [Figure 5-5](#). Remove only enough insulation so that the exposed conductor fits completely under the terminal connection. Best practice is to limit the unshielded length (D) of each conductor to less than one inch. Excessive removal of insulation may result in an unwanted electrical short to the transmitter housing or other terminal connections. Excessive unshielded length, or failure to connect cable shields properly, may also expose the unit to electrical noise, resulting in an unstable meter reading.

Figure 5-5: Cable ends

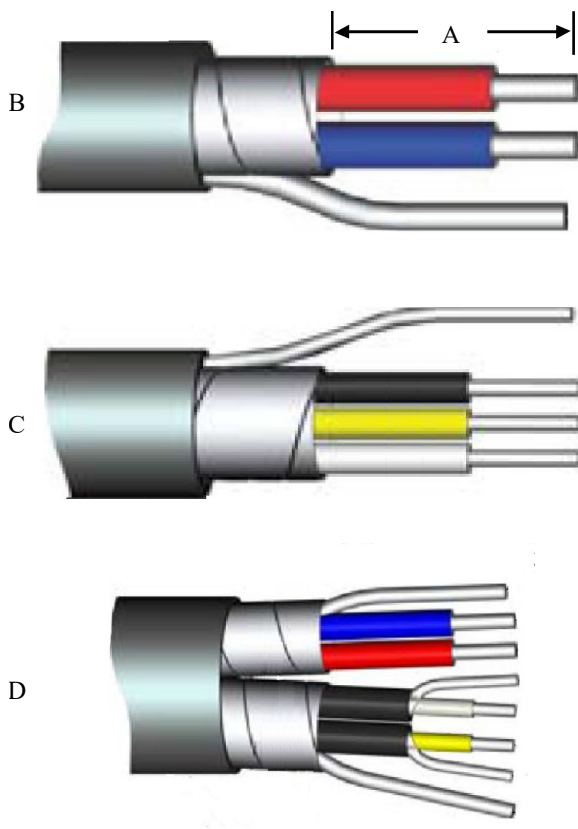

- A. Unshielded length
- B. Coil
- C. Electrode
- D. Combination

⚠ WARNING

Shock hazard! Potential shock hazard across remote junction box terminals 1 and 2 (40V).

⚠ WARNING

Explosion hazard! Electrodes exposed to process. Use only compatible transmitter and approved installation practices. For process temperatures greater than 284°F (140°C), use a wire rated for 257°F (125°C).

Remote junction box terminal blocks

Figure 5-6: Remote junction box views

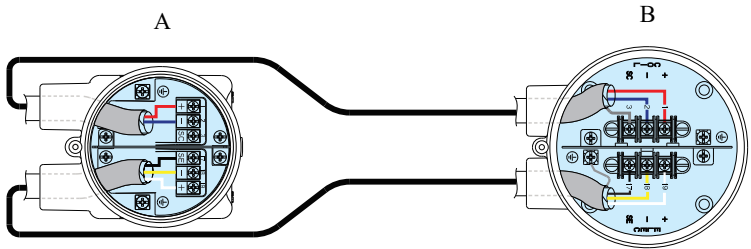

- A. Sensor
- B. Transmitter

Note

Junction box appearance and configuration may vary, but terminal numbering is consistent for all junction box types.

Table 5-4: Sensor/transmitter wiring

Wire color	Sensor terminal	Transmitter terminal
Red	1	1
Blue	2	2
Coil drain	3 or float	3
Black	17	17
Yellow	18	18
White	19	19
Electrode drain	⊕ or float	⊕

Note

For hazardous locations, refer to the product reference manual.

5.4 Wiring sensor to transmitter

Figure 5-7: Wiring 8732EM using component cable

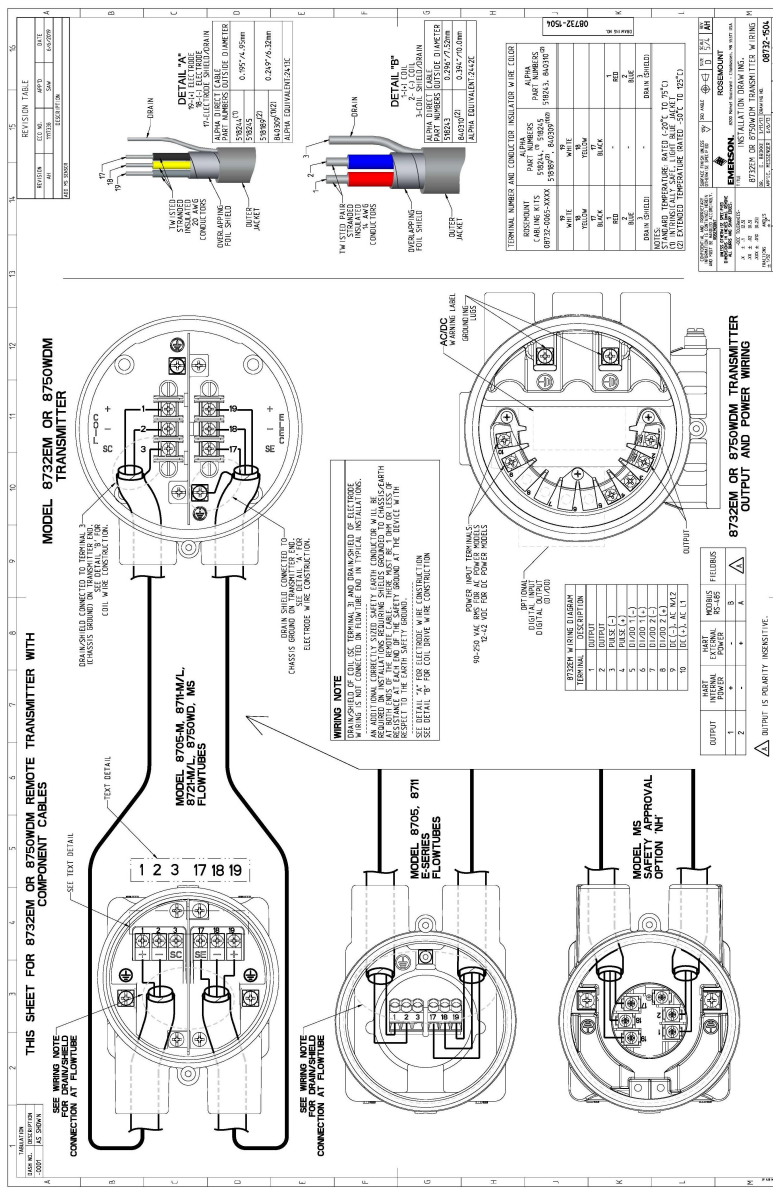
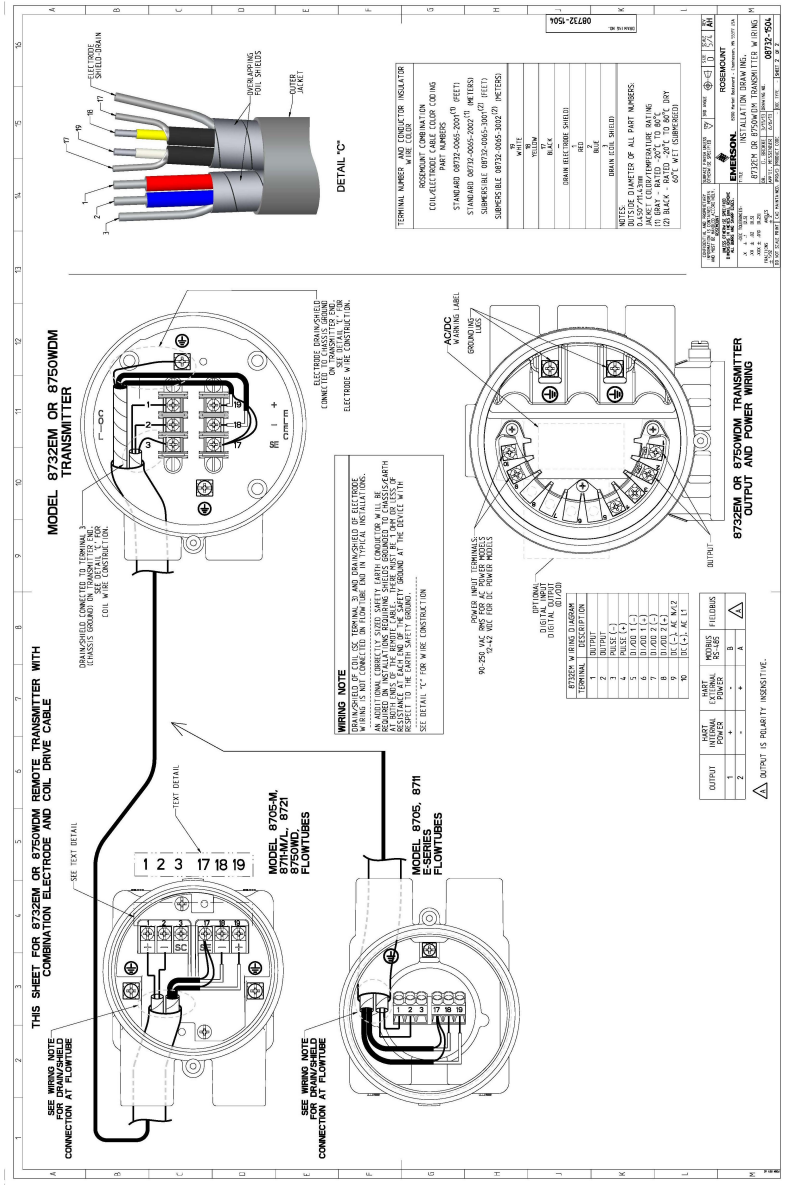

Figure 5-8: Wiring 8732EM using combination cable



5.5 Power and I/O terminal blocks

Remove the back cover of the transmitter to access the terminal block.

Note

To connect pulse output and/or discrete input/output, and for installations with intrinsically safe outputs, refer to the product reference manual.

Figure 5-9: Terminal blocks

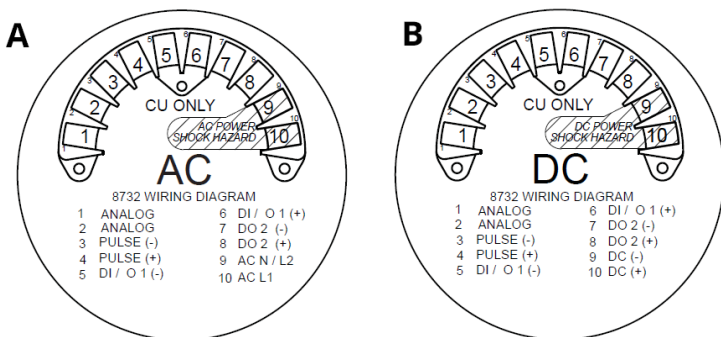

Table 5-5: Power and I/O terminals

Terminal number	AC version	DC version
1	Analog (mA output)	Analog (mA output)
2	Analog (mA output)	Analog (mA output)
3	Pulse (-)	Pulse (-)
4	Pulse (+)	Pulse (+)
5 ⁽¹⁾	Discrete I/O 1 (-)	Discrete I/O 1 (-)
6 ⁽¹⁾	Discrete I/O 1 (+)	Discrete I/O 1 (+)
7 ⁽¹⁾	Discrete Out 2 (-)	Discrete Out 2 (-)
8 ⁽¹⁾	Discrete Out 2 (+)	Discrete Out 2 (+)
9	AC (Neutral)/L2	DC (-)
10	AC L1	DC (+)

(1) Only available with ordering code AX.

5.6 Powering the transmitter

Before connecting power to the transmitter, be sure to have the necessary electrical supplies and required power source:

- The AC powered transmitter requires 90–250V AC (50/60Hz).
- The DC (standard) powered transmitter requires 12–42V DC.
- The DC **low power** transmitter requires 12–30V DC.

Wire the transmitter according to national, local, and plant electrical requirements.

If installing in a hazardous location, verify that the meter has the appropriate hazardous area approval. Each meter has a hazardous area approval tag attached to the top of the transmitter housing.

Supply wire requirements

Use 10–18 AWG wire rated for the proper temperature of the application. For wire 10–14 AWG, use lugs or other appropriate connectors. For connections in ambient temperatures above 122 °F (50 °C), use a wire rated for 194 °F (90 °C). For DC powered transmitters with extended cable lengths, verify that there is a minimum of 12 VDC at the terminals of the transmitter with the device under load.

Electrical disconnect requirements

Connect the device through an external disconnect or circuit breaker per national and local electrical code.

Overcurrent protection

The transmitter requires overcurrent protection of the supply lines. Fuse rating and compatible fuses are shown in Line power fuses. Refer to the product reference manual for more information.

Installation category

The installation category for the transmitter is OVERVOLTAGE CAT II.

AC power system installation requirements

Neutral-earth power requirements

The power system must have a neutral that is locally bonded to earth, or provide both line to earth and neutral to earth voltage limitation of no more than 250 VAC.

Power line impedance

Sources of inductance on the AC power system, such as isolation transformers, must be limited to less than 1 mH at 120 VAC, and 2 mH at 240 VAC.

AC power supply requirements

Units powered by 90 - 250VAC have the following power requirements. Peak inrush is 35.7A at 250VAC supply, lasting approximately 1ms. Inrush for other supply voltages can be estimated with: $\text{Inrush (Amps)} = \text{Supply (Volts)} / 7.0$

Figure 5-10: AC current requirements

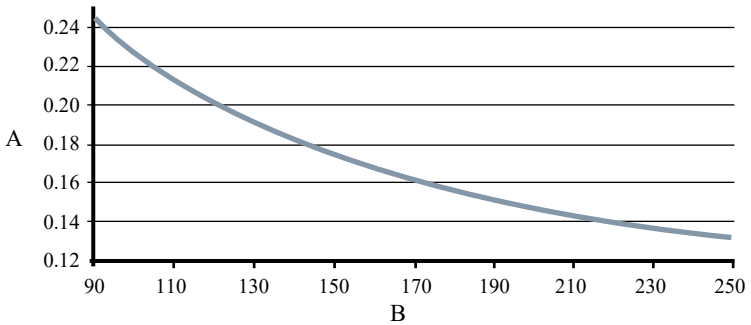

- A. Supply current (amps)
- B. Power supply (VAC)

Figure 5-11: Apparent power

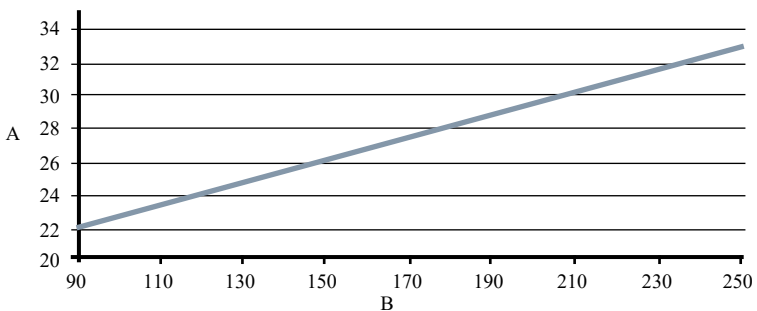

- A. Apparent power (VA)
- B. Power supply (VAC)

DC power supply requirements

Standard DC units powered by 12VDC power supply may draw up to 1.2A of current steady state. Low power DC units may draw up to 0.25A of current steady state. Peak inrush is 42A at 42VDC supply, lasting approximately 1ms. Inrush for other supply voltages can be estimated with: $\text{Inrush (Amps)} = \text{Supply (Volts)} / 1.0$

Figure 5-12: DC current requirements

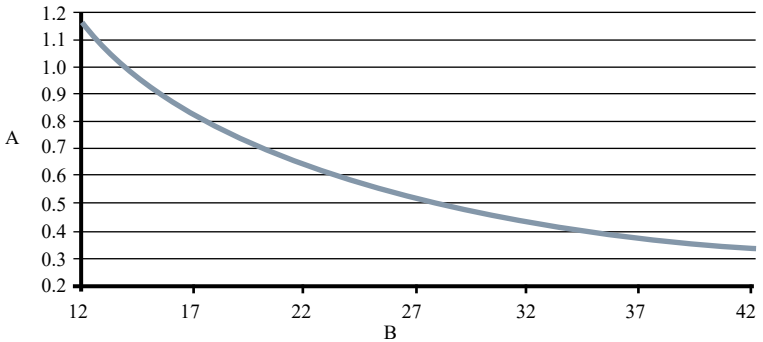

- A. Supply current (amps)
- B. Power supply (VDC)

Figure 5-13: Low power DC current requirements

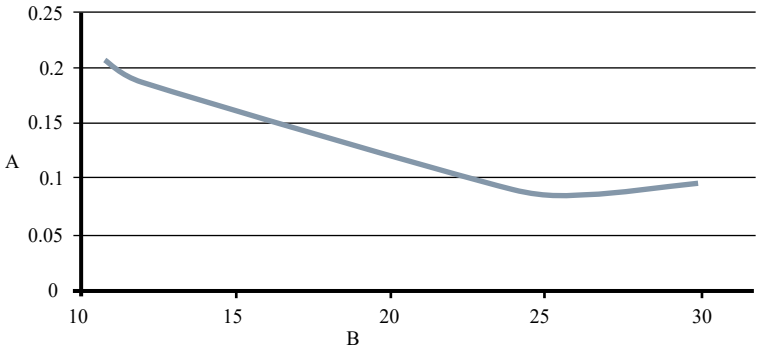

- A. Supply current (amps)
- B. Power supply (VDC)

Table 5-6: Fuse requirements

Power system	Power supply	Fuse rating	Manufacturer
AC power	90–250VAC	2 Amp quick acting	Bussman AGC2 or equivalent
DC power	12–42VDC	3 Amp quick acting	Bussman AGC3 or equivalent
DC low power	12–30VDC	3 Amp quick acting	Bussman AGC3 or equivalent

Power terminals

For AC powered transmitter (90–250VAC, 50/60 Hz):

- Connect AC Neutral to terminal 9 (AC N/L2) and AC Line to terminal 10 (AC/L1).

For DC powered transmitter:

- Connect negative to terminal 9 (DC -) and positive to terminal 10 (DC +).
- DC powered units may draw up to 1.2A.

Cover jam screw

For flow meters shipped with a cover jam screw, the screw should be installed after the instrument has been wired and powered up. Follow these steps to install the cover jam screw:

1. Verify the cover jam screw is completely threaded into the housing.
2. Install the housing cover and verify the cover is tight against the housing.
3. Using a 2.5 mm hex wrench, loosen the jam screw until it contacts the transmitter cover.
4. Turn the jam screw an additional ½ turn counterclockwise to secure the cover.

Note

Application of excessive torque may strip the threads.

5. Verify the cover cannot be removed.

5.7 Analog output

The analog output signal is a 4-20 mA current loop. Depending on the IS output option, the loop can be powered internally or externally

via a hardware switch located on the front of the electronics stack. The switch is set to internal power when shipped from the factory. For units with a display, the LOI must be removed to change switch position. Intrinsically safe analog output requires a shielded twisted pair cable. For HART communication, a minimum resistance of 250 ohms is required. It is recommended to use individually shielded twisted pair cable. The minimum conductor size is 24 AWG (0.51 mm) diameter for cable runs less than 5,000 feet (1,500 m) and 20 AWG (0.81 mm) diameter for longer distances.

Note

For more information about the analog output characteristics, refer to the product reference manual.

Figure 5-14: Analog output wiring

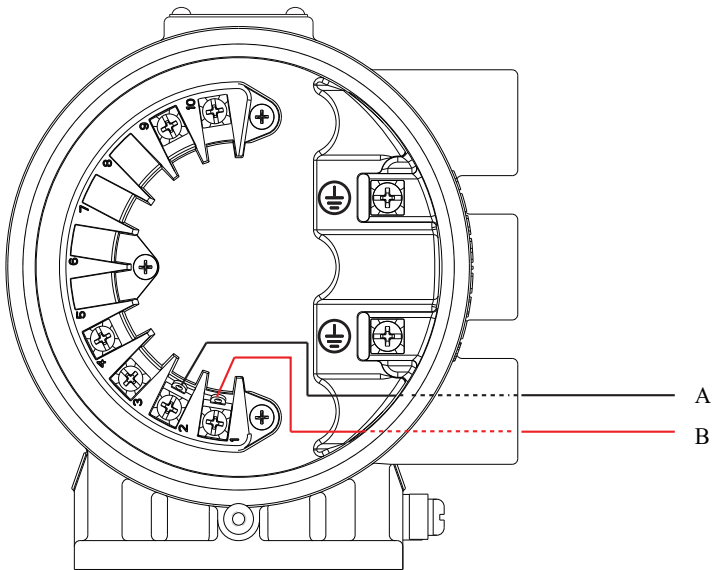

- A. Terminal #2
- B. Terminal #1

Table 5-7: Terminal assignment by power source type

Power source	Terminal #1	Terminal #2
Internal	4–20 mA negative (-)	4–20 mA positive (+)
External	4–20 mA positive (+)	4–20 mA negative (-)

Table 5-8: Terminal assignment by power source type

Power source	Terminal #7	Terminal #8
Internal	4–20 mA negative (-)	4–20 mA positive (+)
External	4–20 mA positive (+)	4–20 mA negative (-)

Figure 5-15: Analog loop load limitations

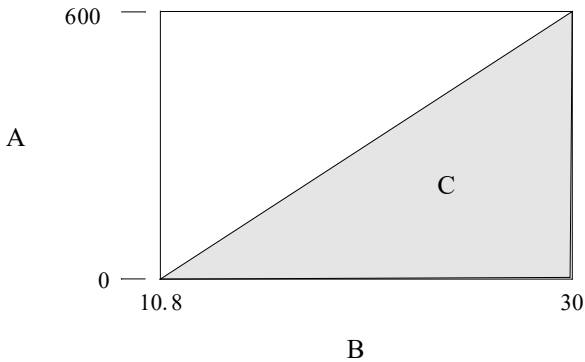

- A. Load (ohms)
- B. Power supply (volts)
- C. Operating region

- $R_{max} = 31.25 (V_{ps} - 10.8)$
- V_{ps} = power supply voltage (volts)
- R_{max} = maximum loop resistance (ohms)

6 Basic Configuration

Once the flow meter is installed and power has been supplied, the transmitter must be configured using the LOI, if equipped, or a configuration tool, such as ProLink III Software, AMS Device Manager, or AMS Trex Device Communicator. Configuration settings are saved in nonvolatile memory within the transmitter. Descriptions of more advanced functions are included in the product reference manual.

6.1 Basic Setup

Tag

Tag is the quickest and shortest way of identifying and distinguishing between transmitters. Transmitters can be tagged according to the requirements of your application. HART Rev 5 supports 8 character short tag. HART Rev 7 supports 8 character short tag and 32 character long tag.

Calibration number

The sensor calibration number is a 16-digit number generated at the factory during flow calibration, is unique to each sensor, and is located on the sensor nameplate.

Flow units (PV)

The flow units variable specifies the format in which the flow rate will be displayed. Units should be selected to meet your particular metering needs.

Line size

The line size (sensor size) must be set to match the actual sensor connected to the transmitter. The size must be specified in inches.

Upper range value (URV)

The URV sets the 20 mA point for the analog output. This value is typically set to full-scale flow. The units that appear will be the same as those selected under the flow units parameter. The URV may be set between -39.3 ft/s to 39.3 ft/s (-12 m/s to 12m/s). There must be at least 1 ft/s (0.3 m/s) span between the URV and LRV.

Note

If entering a negative number, the minus sign must be entered in the furthest left position on the LOI.

Lower range value (LRV)

The LRV sets the 4 mA point for the analog output. This value is typically set to zero flow. The units that appear will be the same as those selected under the flow units parameter. The LRV may be set between -39.3 ft/s to 39.3 ft/s (-12 m/s to 12 m/s). There must be at least 1 ft/s (0.3 m/s) span between the URV and LRV.

Note

If entering a negative number, the minus sign must be entered in the furthest left position on the LOI.

6.2 Local operator interface (LOI)

To activate the optional LOI, press the DOWN arrow.

Use the UP, DOWN, LEFT(E), and RIGHT arrows to navigate the menu structure.

A complete map of the LOI menu structure is shown in the product reference manual.

The display can be locked to prevent unintentional configuration changes. The display lock can be activated through a HART communication device, or by holding the UP arrow for three seconds and then following the on-screen instructions.

6.3 Other configuration tools

Table 6-1 shows the approximate category or location of basic setup parameters for typical configuration tools.

Table 6-1: Approximate setup category/locations for typical configuration tools

Function	Category/Location
Flow Units	Basic Setup
PV Upper Range Value (URV)	Basic Setup → AO
PV Lower Range Value (LRV)	Basic Setup → AO
Calibration Number	Basic Setup → Setup
Line Size	Basic Setup → Setup
Tag	Device Info → Identification
Long Tag	Device Info → Identification



Quick Start Guide
00825-0100-4444, Rev. AJ
June 2024

For more information: [Emerson.com/global](https://emerson.com/global)

©2024 Emerson. All rights reserved.

Emerson Terms and Conditions of Sale are available upon request. The Emerson logo is a trademark and service mark of Emerson Electric Co. Rosemount is a mark of one of the Emerson family of companies. All other marks are the property of their respective owners.

ROSEMOUNT™

